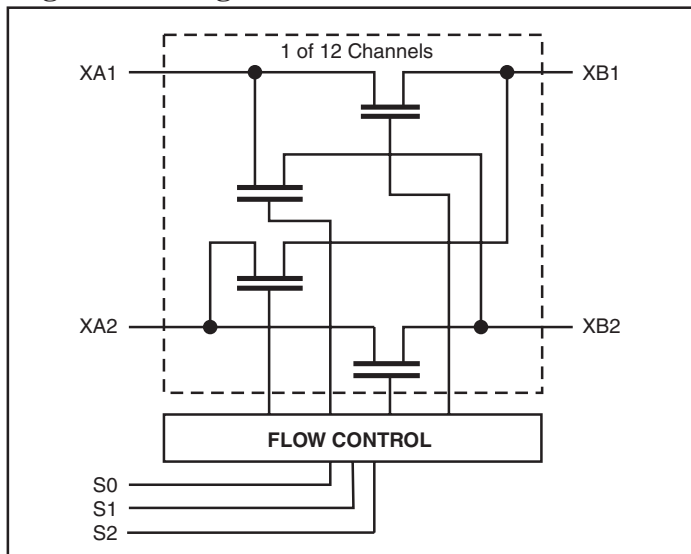
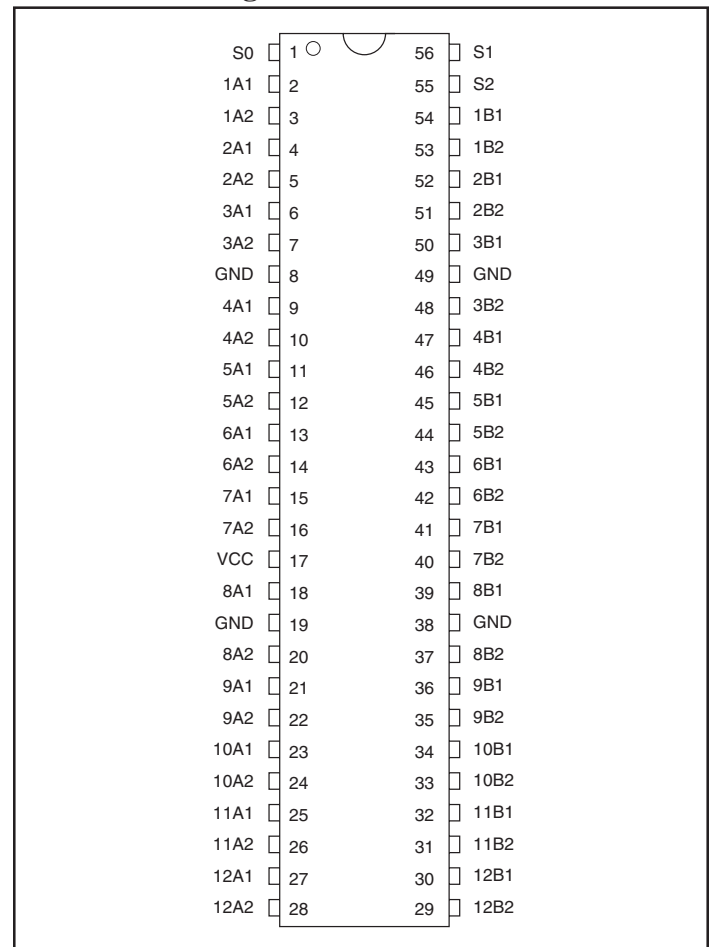

**Product Features**

- Near-zero propagation delay
- 5-ohm switches connect inputs to outputs
- Direct bus connection when switches are ON
- Fast Switching Speed: 5.5ns(max.)
- Operating  $V_{CC}$  Range: 3.0V to 3.6V
- Industrial operating temperature:  $-40^{\circ}\text{C}$  to  $+85^{\circ}\text{C}$
- Packages available:
  - 56-pin 240-mil wide thin plastic TSSOP (A)

**Product Description**

The PI3B16213 is a 3.3 volt, 24-bit bus-exchange switch designed with a low On-Resistance allowing connections to be made with minimal propagation delay. This device operates either as a 24-bit or as a 12-bit bus switch, providing data exchange between the four signal ports via the data-select (S0-S2) terminals.

**Logic Block Diagram**

**Product Pin Configuration**

**Truth Table<sup>(1)</sup>**

Function	S2	S1	S0	A1	A2
Disconnect	L	L	L	Z	Z
A1 to B1	L	L	H	B1	Z
A1 to B2	L	H	L	B2	Z
A2 to B1	L	H	H	Z	B1
A2 to B2	H	L	L	Z	B2
A1 to A2 and B2	H	L	H	A2/B2	A1/B2
A1 to B1, A2 to B2	H	H	L	B1	B2
A1 to B2, A2 to B1	H	H	H	B2	B1

**Note:**

1. H = High Voltage Level  
L = Low Voltage Level  
Z = High Impedance

**Product Pin Description**

Pin Name	I/O	Description
S0-S2	I	Select Inputs
xAx	I/O	Bus A
xBx	I/O	Bus B

**Maximum Ratings**

(Above which useful life may be impaired. For user guidelines, not tested.)

Storage Temperature .....	-65°C to +150°C
Ambient Temperature with Power Applied .....	-40°C to +85°C
Supply Voltage Range .....	-0.5V to +4.60V
DC Input Voltage .....	-0.5V to +4.60V
DC Output Current .....	120mA
Power Dissipation .....	1 W

**Note:**

Stresses greater than those listed under MAXIMUM RATINGS may cause permanent damage to the device. This is a stress rating only and functional operation of the device at these or any other conditions above those indicated in the operational sections of this specification is not implied. Exposure to absolute maximum rating conditions for extended periods may affect reliability.

**Electrical Characteristics** (Over the Operating Range,  $T_A = -40^\circ\text{C}$  to  $+85^\circ\text{C}$ ,  $V_{CC} = 3.0\text{V}$  to  $3.6\text{V}$ )

Parameters	Description		Test Conditions		Min.	Typ <sup>(1)</sup>	Max.	Units
$V_{IK}$	Input HIGH Voltage		$V_{CC} = \text{Min.}$	$I_I = -18\text{mA}$			-1.2	V
$I_I$	Input Current		$V_{CC} = 0$	$V_I = \text{Max.}$			10	$\mu\text{A}$
			$V_{CC} = \text{Max.}$	$V_I = \text{Max. or GND}$			$\pm 1$	
$I_{CC}$	Quiescent Power Supply Current		$V_{CC} = \text{Max.}, I_O = 0$	$V_I = V_{CC} \text{ or GND}$			10	
$C_{IN}^{(2)}$	Input Capacitance		$V_{IN} = 0\text{V}$				3	pF
$C_{OFF}^{(2)}$	Switch Off, A/B Capacitance		$V_{IN} = 0\text{V}; S_0, S_1, S_2 = \text{GND}$				14	
$R_{ON}^{(3)}$	A to B	$V_{CC} = \text{Min.}$	$V_{CC} = \text{Min.}$	$V_I = 0$	$I_I = 30\text{mA}$	5	8	$\Omega$
					$I_I = 64\text{mA}$	5	8	
				$V_I = 2.4\text{V}$	$I_I = 15\text{mA}$	10	15	
	A1 to A2	$V_{CC} = \text{Min.}$	$V_{CC} = \text{Min.}$	$V_I = 0$	$I_I = 30\text{mA}$	10	14	
					$I_I = 64\text{mA}$	10	14	
				$V_I = 2.4\text{V}$	$I_I = 15\text{mA}$	20	30	

**Notes:**

1. Typical values are at  $V_{CC} = 3.3\text{V}$ ,  $T_A = 25^\circ\text{C}$  ambient and maximum loading.
2. This parameter is determined by device characterization but is not production tested.
3. Measured by the voltage drop between A and B pin at indicated current through the switch. ON resistance is determined by the lower of the voltages on the two (A,B) pins.

**Recommended Operating Conditions**

Parameters	Description	Min.	Typ <sup>(1)</sup>	Max.	Units
V <sub>CC</sub>	Supply voltage	3.0		3.6	V
V <sub>IH</sub>	High-level input voltage	2			
V <sub>IL</sub>	Low-level input voltage			0.8	
T <sub>A</sub>	Operating free-air temperature	-40		85	°C

**Notes:**

1. Typical values are at V<sub>CC</sub>=3.3V, +25°C ambient.

**PI3B16213 Switching Characteristics over Operating Range**

Parameters	From (Input)	To (Output)	V <sub>CC</sub> = 3.0 V to 3.6V		Units
			Min.	Max.	
t <sub>PD</sub> <sup>(1)</sup>	A or B	B or A		0.25	ns
	A1	A2		0.5	
t <sub>EN</sub>	S	A or B	1	4.5	
t <sub>DIS</sub>	S	A or B	1	5.5	
t <sub>EN</sub>	S0	A1 and A2	1	4.5	
t <sub>DIS</sub>	S0	A1 and A2	1	5.5	

**Note:**

1. This parameter is guaranteed but not tested on Propagation Delays. The bus switch contributes no propagational delay other than the RC delay of the ON resistance of the switch and the load capacitance. The time constant for the switch alone is of the order of 0.25ns for 50pF load. Since this time constant is much smaller than the rise/fall times of typical driving signals, it adds very little propagational delay to the system. Propagational delay of the bus switch when used in a system is determined by the driving circuit on the driving side of the switch and its interaction with the load on the driven side.

**Packaging Mechanical: 56-Pin TSSOP (A) Package**

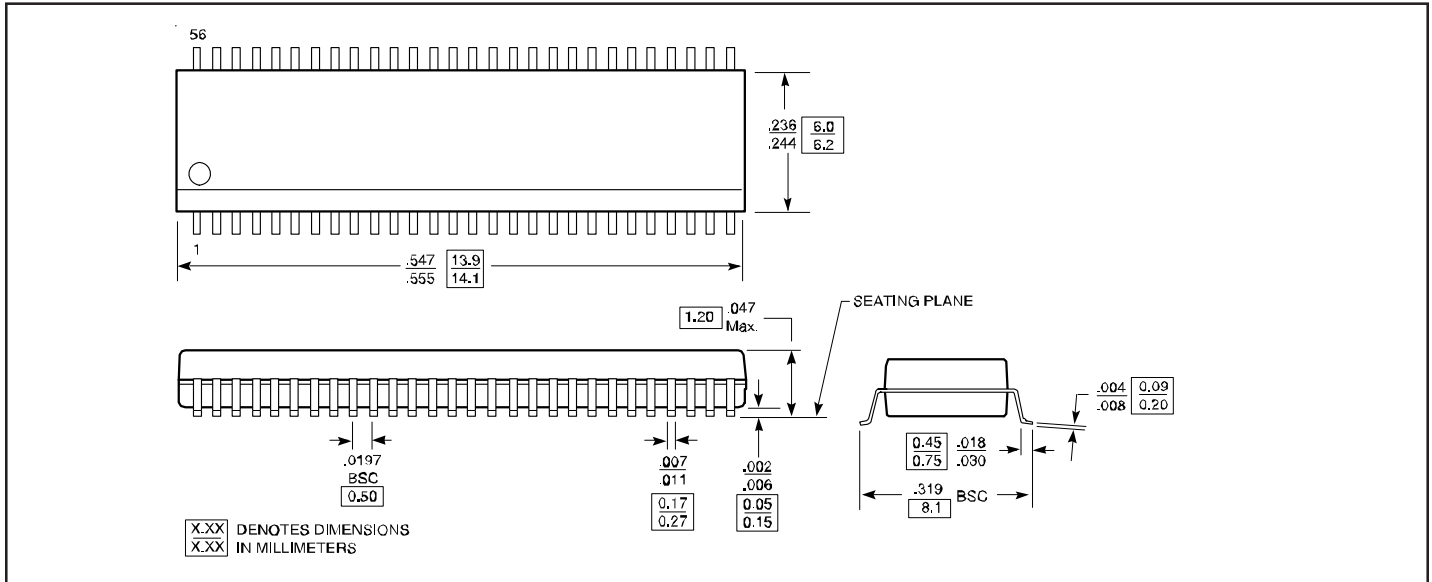

**Ordering Information**

Ordering Code	Package Code	Package Description
PI3B16213A	A	56-pin 240-mil wide TSSOP

**Notes:**

- Thermal characteristics can be found on the company web site at [www.pericom.com/packaging/](http://www.pericom.com/packaging/)
- Adding an X suffix = Tape/Reel