

DM74123 Dual Retriggerable One-Shot with Clear and Complementary Outputs

General Description

The '123 is a dual retriggerable monostable multivibrator capable of generating output pulses from a few nano-seconds to extremely long duration up to 100% duty cycle. Each device has three inputs permitting the choice of either leading-edge or trailing edge triggering. Pin (A) is an active-low transition trigger input and pin (B) is an active-high transition trigger input. A low at the clear (CLR) input terminates the output pulse: which also inhibits triggering. An internal connection from CLR to the input gate makes it possible to trigger the circuit by a positive-going signal on CLR as shown in the truth table.

To obtain the best and trouble free operation from this device please read the operating rules as well as the NSC one-shot application notes carefully and observe recommendations.

Features

- DC triggered from active-high transition or active-low transition inputs
- Retriggerable to 100% duty cycle
- Direct reset terminates output pulse
- Compensated for V_{CC} and temperature variations
- DTL, TTL compatible
- Input clamp diodes

Functional Description

The basic output pulse width is determined by selection of an external resistor (R_x) and capacitor (C_x). Once triggered, the basic pulse width may be extended by retriggering the gated active-low transition or active-high transition inputs or be reduced by use of the active-low transition clear input. Retriggering to 100% duty cycle is possible by application of an input pulse train whose cycle time is shorter than the output cycle time such that a continuous "HIGH" logic state is maintained at the "Q" output.

Connection Diagram

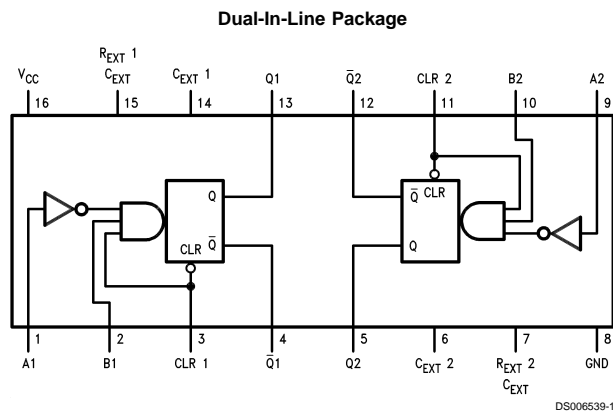

**Order Number DM54123J-MIL, DM54123W-MIL
or DM74123N
See Package Number J16A, N16A or W16A**

Triggering Truth Table

Inputs			Response
A	B	CLR	
X	X	L	No Trigger
~	L	X	No Trigger
~	H	H	Trigger
H	~	X	No Trigger
L	~	H	Trigger
L	H	~	Trigger

H = HIGH Voltage Level
L = LOW Voltage Level
X = Immaterial

Absolute Maximum Ratings (Note 1)

Supply Voltage	7V	DM54	-55°C to +100°C
Input Voltage	5.5V	DM74	0°C to +70°C
Operating Free Air Temperature Range		Storage Temperature	-65°C to +150°C

Recommended Operating Conditions

Symbol	Parameter	DM54123			DM74123			Units
		Min	Nom	Max	Min	Nom	Max	
V _{CC}	Supply Voltage	4.5	5	5.5	4.75	5	5.25	V
V _{IH}	High Level Input Voltage	2			2			V
V _{IL}	Low Level Input Voltage			0.8			0.8	V
I _{OH}	High Level Output Current			-0.8			-0.8	mA
I _{OL}	Low Level Output Current			16			16	mA
t _w	Pulse Width (Note 6)	A or B High			40			ns
		A or B Low			40			
		Clear Low			40			
T _{WQ} (Min)	Minimum Width of Pulse at Q (Note 6)	A or B		80			65	ns
R _{EXT}	External Timing Resistor				5		50	kΩ
C _{EXT}	External Timing Capacitance	No Restriction						μF
C _{WIRE}	Wiring Capacitance at R _{EXT} /C _{EXT} Terminal (Note 6)						50	pF
T _A	Free Air Operating Temperature	-55		125	0		70	°C

Note 1: The "Absolute Maximum Ratings" are those values beyond which the safety of the device cannot be guaranteed. The device should not be operated at these limits. The parametric values defined in the "Electrical Characteristics" table are not guaranteed at the absolute maximum ratings. The "Recommended Operating Conditions" table will define the conditions for actual device operation.

Electrical Characteristics

over recommended operating free air temperature range (unless otherwise noted)

Symbol	Parameter	Conditions	Min	Typ (Note 2)	Max	Units
V _I	Input Clamp Voltage	V _{CC} = Min, I _I = -12 mA			-1.5	V
V _{OH}	High Level Output Voltage	V _{CC} = Min, I _{OH} = Max	DM54	2.4	3.4	V
		V _{IL} = Max, V _{IH} = Min	DM74	2.5		
V _{OL}	Low Level Output Voltage	V _{CC} = Min, I _{OL} = Max V _{IH} = Min, V _{IL} = Max		0.2	0.4	V
I _I	Input Current @ Max Input Voltage	V _{CC} = Max, V _I = 5.5V			1	mA
I _{IH}	High Level Input Current	V _{CC} = Max V _I = 2.4V	Data		40	μA
			Clear		80	
I _{IL}	Low Level Input Current	V _{CC} = Max, V _I = 0.4V	Clear		-3.2	mA
			Data		-1.6	
I _{OS}	Short Circuit Output Current	V _{CC} = Max (Note 3)	DM54	-10	-40	mA
			DM74	-10	-40	
I _{CC}	Supply Current	V _{CC} = Max (Notes 4, 5)		46	66	mA

Note 2: All typicals are at V_{CC} = 5V, T_A = 25°C.

Note 3: Not more than one output should be shorted at a time.

Note 4: Quiescent I_{CC} is measured (after clearing) with 2.4V applied to all clear and A inputs, B inputs grounded, all outputs open, C_{EXT} = 0.02 μF, and R_{EXT} = 25 kΩ.

Note 5: I_{CC} is measured in the triggered state with 2.4V applied to all clear and B inputs, A inputs grounded, all outputs open, C_{EXT} = 0.02 μF, and R_{EXT} = 25 kΩ.

Note 6: T_A = 25°C and V_{CC} = 5V.

Switching Characteristics

at $V_{CC} = 5V$ and $T_A = 25^\circ C$

Symbol	Parameter	From (Input) To (Output)	DM54123		DM74123		Units
			$C_L = 15 \text{ pF}, R_L = 400\Omega$		$C_L = 15 \text{ pF}, R_L = 400\Omega$		
			$C_{EXT} = 0 \text{ pF}, R_{EXT} = 5 \text{ k}\Omega$		$C_{EXT} = 1000 \text{ pF}, R_{EXT} = 10 \text{ K}\Omega$		
			Min	Max	Min	Max	
t_{PLH}	Propagation Delay Time Low to High Level Output	\bar{A} to Q		33		33	ns
t_{PLH}	Propagation Delay Time Low to High Level Output	B to Q		28		28	ns
t_{PHL}	Propagation Delay Time High to Low Level Output	\bar{A} to \bar{Q}		40		40	ns
t_{PHL}	Propagation Delay Time High to Low Level Output	B to \bar{Q}		36		36	ns
t_{PLH}	Propagation Delay Time Low to High Level Output	Clear to \bar{Q}		40		40	ns
t_{PHL}	Propagation Delay Time High to Low Level Output	$\bar{\text{Clear}}$ to Q		27		27	ns
$t_{W(out)}$	Output Pulse Width (Note 7)	A or B to Q	3.08	3.76	3.08	3.76	μs

Note 7: $C_{EXT} = 1000 \text{ pF}, R_{EXT} = 10 \text{ k}\Omega$

Operating Rules

- An external resistor (R_X) and external capacitor (C_X) are required for proper operation. The value of C_X may vary from 0 to any necessary value. For small time constants high-grade mica, glass, polypropylene, polycarbonate, or polystyrene material capacitors may be used. For large time constants use tantalum or special aluminum capacitors. If the timing capacitors have leakages approaching 100 nA or if stray capacitance from either terminal to ground is greater than 50 pF the timing equations may not represent the pulse width the device generates.
- When an electrolytic capacitor is used for C_X a switching diode is often required for standard TTL one-shots to prevent high inverse leakage current (Figure 1). However, its use in general is not recommended with retriggerable operation.
- The output pulse width (T_W) for $C_X > 1000 \text{ pF}$ is defined as follows:

$$T_W = K R_X C_X (1 + 0.7/R_X)$$

A. where: [R_X is in Kilo-ohm]

[C_X is in pico Farad]

[T_W is in nano second]

[$K \approx 0.28$]

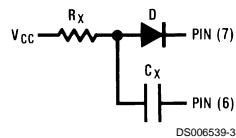

FIGURE 1.

- For $C_X < 1000 \text{ pF}$ see Figure 2 for T_W vs C_X family curves with R_X as a parameter:

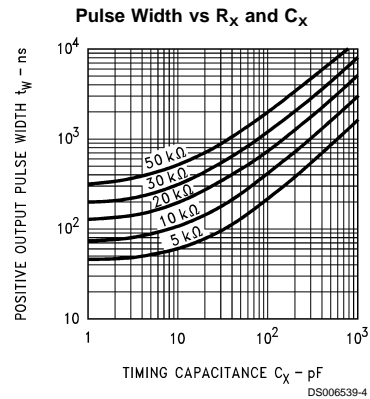
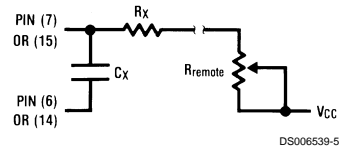

FIGURE 2.

- To obtain variable pulse width by remote trimming, the following circuit is recommended:



Note: " R_{remote} " should be as close to the one-shot as possible.

FIGURE 3.

Operating Rules (Continued)

6. The retriggerable pulse width is calculated as shown below:

$$T = T_W + t_{PLH} = Kx R_x \times C_x + t_{PLH}$$

The retriggered pulse width is equal to the pulse width plus a delay time period (Figure 4).

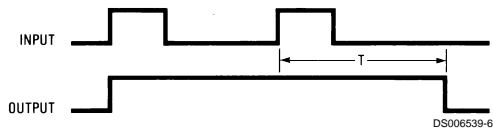

FIGURE 4.

7. Under any operating condition C_x and R_x must be kept as close to the one-shot device pins as possible to mini-

mize stray capacitance, to reduce noise pick-up, and to reduce $I \times R$ and Ldi/dt voltage developed along their connecting paths. If the lead length from C_x to pins (6) and (7) or pins (14) and (15) is greater than 3 cm, for example, the output pulse width might be quite different from values predicted from the appropriate equations. A non-inductive and low capacitive path is necessary to ensure complete discharge of C_x in each cycle of its operation so that the output pulse width will be accurate.

8. V_{CC} and ground wiring should conform to good high-frequency standards and practices so that switching transients on the V_{CC} and ground return leads do not cause interaction between one-shots. A 0.01 μF to 0.10 μF bypass capacitor (disk ceramic or monolithic type) from V_{CC} to ground is necessary on each device. Furthermore, the bypass capacitor should be located as close to the V_{CC} pin as space permits.

Note: For further detailed device characteristics and output performance please refer to the NSC one-shot application note, AN-366.



Physical Dimensions inches (millimeters) unless otherwise noted

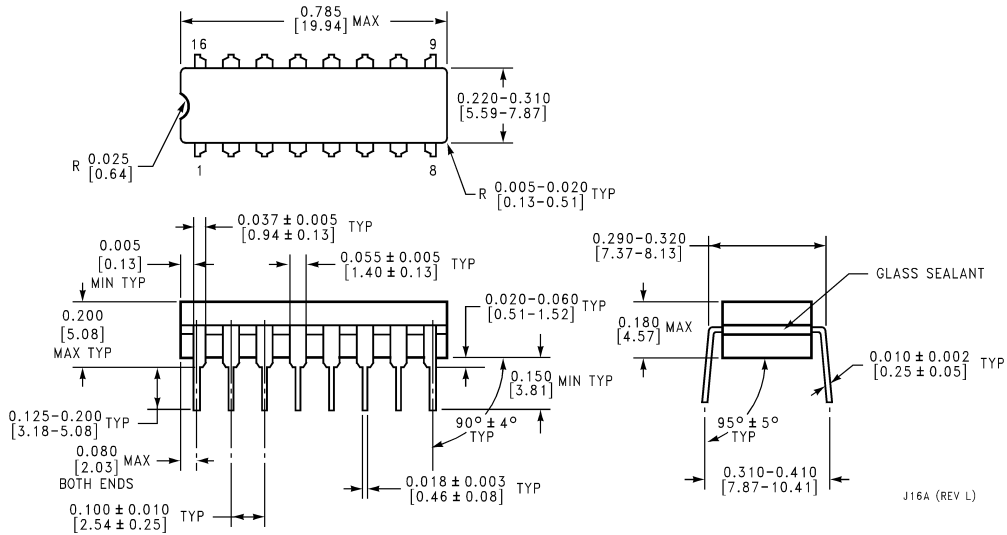

Ceramic Dual-In-Line Package (J)
Order Number DM54123J-MIL
Package Number J16A

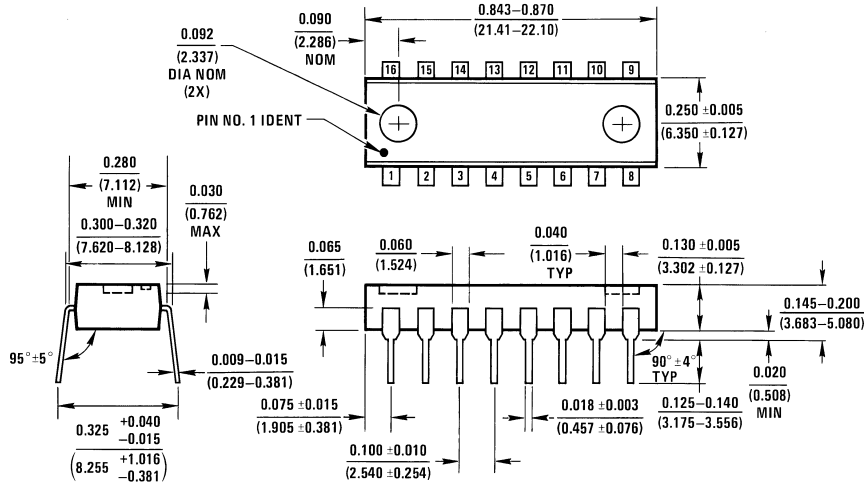

Molded Dual-In-Line Package (N)
Order Number DM74123N
Package Number N16A

Physical Dimensions inches (millimeters) unless otherwise noted (Continued)

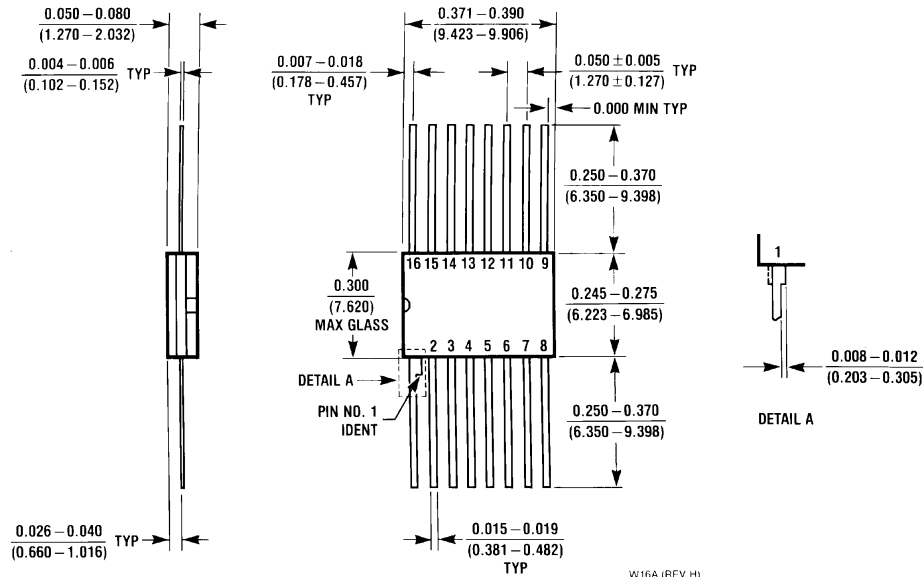

16-Lead Ceramic Flat Package (W)
Order Number DM54123W-MIL
Package Number W16A

LIFE SUPPORT POLICY

FAIRCHILD'S PRODUCTS ARE NOT AUTHORIZED FOR USE AS CRITICAL COMPONENTS IN LIFE SUPPORT DEVICES OR SYSTEMS WITHOUT THE EXPRESS WRITTEN APPROVAL OF THE PRESIDENT OF FAIRCHILD SEMICONDUCTOR CORPORATION. As used herein:

1. Life support devices or systems are devices or systems which, (a) are intended for surgical implant into the body, or (b) support or sustain life, and (c) whose failure to perform when properly used in accordance with instructions for use provided in the labeling, can be reasonably expected to result in a significant injury to the user.
2. A critical component in any component of a life support device or system whose failure to perform can be reasonably expected to cause the failure of the life support device or system, or to affect its safety or effectiveness.

Fairchild Semiconductor Corporation Americas
 Customer Response Center
 Tel: 1-888-522-5372

Fairchild Semiconductor Europe
 Fax: +49 (0) 1 80-530 85 86
 Email: europe.support@nsc.com
 Deutsch Tel: +49 (0) 8 141-35-0
 English Tel: +44 (0) 1 793-85-68-56
 Italy Tel: +39 (0) 2 57 5631

Fairchild Semiconductor Hong Kong Ltd.
 13th Floor, Straight Block,
 Ocean Centre, 5 Canton Rd.
 Tsimshatsui, Kowloon
 Hong Kong
 Tel: +852 2737-7200
 Fax: +852 2314-0061

National Semiconductor Japan Ltd.
 Tel: 81-3-5620-6175
 Fax: 81-3-5620-6179

www.fairchildsemi.com

Fairchild does not assume any responsibility for use of any circuitry described, no circuit patent licenses are implied and Fairchild reserves the right at any time without notice to change said circuitry and specifications.