

# SPT mV Series 0 to 3psi to 0 to 5000psi

Low Cost, Stainless Steel Pressure Transducer



## General Description

The SPT stainless steel devices were developed for pressure applications that involve measurement of hostile media in harsh environments. These sensors will accommodate any media that will not adversely attack 304 or 316 stainless steel.

These SPT mV series transducers are calibrated and temperature compensated when used with a constant Voltage source. They feature a variety of pressure connections to allow use in a wide range of OEM equipment.

The SPT stainless steel devices are rugged and reliable transducers for use in a wide variety of pressure sensing applications where corrosive liquids or gases are monitored. Contact your local Invensys representative or the Invensys factory for additional details.

## Features

### Reliable Semiconductor Technology

- Calibrated and Temperature Compensated
- Rugged--Stainless Steel Package
- NEMA 4 Rated
- Small Size
- Absolute, Gauge, Sealed Gauge, & Vacuum Gauge Pressures
- Reliable Semiconductor Technology

### Applications

- Industrial Automation and Flow Control
- Pressure Instrumentation
- Hydraulic Systems
- Process Control
- Flow Control

## Equivalent Circuit

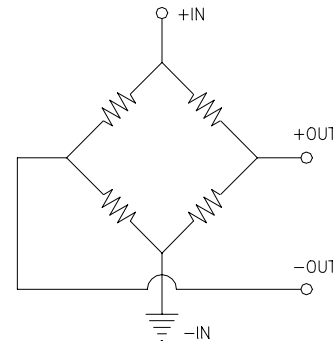

## Ordering Information - Part # Description

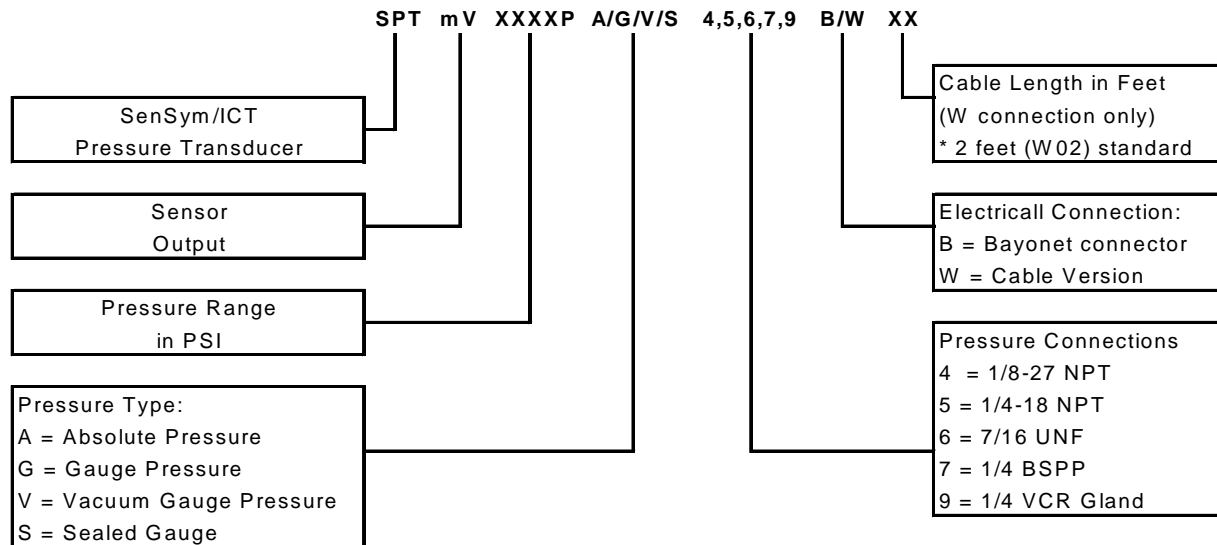

For example: Part #SPTmV0100PA4W02 = SPT mV Sensor, 100 psi, Absolute, 1/8NPT Port, with a 2 feet cable (pigtail) electrical connection.

\* NOTE: Cable Length is 2 feet standard (W02) unless otherwise specified.

## Pressure Transducer Characteristics

### Environmental Specifications

Compensated: -10°C to +85°C  
 Operating: -40°C to +125°C  
 Storage: -40°C to +125°C

Vibration: 10G at 20-2000 Hz  
 Shock: 100G for 11 msec  
 Life: 1 Million cycles minimum  
 Insulation Resistance 100MΩ at 50 Vdc

### Maximum Supply Ratings

Supply Voltage  $V_S = +15$  Vdc

### Pressure Range Specifications

SenSym/ICT Part Number *	Pressure Range	Proof Pressure (7)	Burst Pressure (8)
SPT mV 0003P G (4,5,6,7,9) (B/WXX)	0-3 psig	9 psig	15 psig
SPT mV 0005P G (4,5,6,7,9) (B/WXX)	0-5 psig	15 psig	25 psig
SPT mV 0010P G (4,5,6,7,9) (B/WXX)	0-10 psig	30 psig	30 psig
SPT mV 0015P (A,G,V) (4,5,6,7,9) (B/WXX)	0-15 psi	45 psi	75 psi
SPT mV 0030P (A,G,V) (4,5,6,7,9) (B/WXX)	0-30 psi	90 psi	150 psi
SPT mV 0050P (A,G) (4,5,6,7,9) (B/WXX)	0-50 psi	150 psi	250 psi
SPT mV 0100P (A,G,V) (4,5,6,7,9) (B/WXX)	0-100 psi	300 psi	500 psi
SPT mV 0200P (A,G) (4,5,6,7,9) (B/WXX)	0-200 psi	600 psi	1000 psi
SPT mV 0300P (A,G) (4,5,6,7,9) (B/WXX)	0-300 psi	900 psi	1500 psi
SPT mV 0500P (A,G) (4,5,6,7,9) (B/WXX)	0-500 psi	1200 psi	2400 psi
SPT mV 1000P (A,S) (4,5,6,7) (B/WXX)	0-1000 psi	3000 psia	5000 psia
SPT mV 2000P (A,S) (4,5,6,7) (B/WXX)	0-2000 psi	6000 psia	10000 psia
SPT mV 3000P (A,S) (4,5,6,7) (B/WXX)	0-3000 psi	9000 psia	10000 psia
SPT mV 5000P (A,S) (4,5,6,7) (B/WXX)	0-5000 psi	10000 psia	10000 psia

\* Note: Parts are available in Absolute, Gauge, Vacuum Gauge, and Sealed Gauge pressures (A=Absolute, G=Gauge, V=Vacuum Gauge, S=Sealed Gauge) a variety of pressure connections/ports (4,5,6,7,9).

Performance Characteristics <sup>(1)</sup>

Characteristic	Min	Typical	Max	Units
Zero pressure offset	-2	0	+2	mV
Full scale span (0-3 and 0-3000 psi only) <sup>(2)</sup>	98	100	102	mV
Full scale span (0-5000 psi only) <sup>(2)</sup>	148	150	152	mV
Nonlinearity <sup>(3)</sup>	--	±0.1	±0.25	%FSS
Pressure hysteresis <sup>(3)</sup>	--	±0.015	±0.030	%FSS
Repeatability	--	±0.010	±0.030	%FSS
Temp. effect on span <sup>(4)</sup>	--	±0.5	±1.0	%FSS
Temp. effect on offset <sup>(4)</sup>	--	±0.5	±1.0	%FSS
Temp. effect on span (0-3 and 0-5 psi only) <sup>(4)</sup>	--	--	±2.0	%FSS
Temp. effect on offset (0-3 and 0-5 psi only) <sup>(4)</sup>	--	--	±2.0	%FSS
Thermal hysteresis (-10 to +85°C)	--	±0.1	±0.3	%FSS
Long term stability of offset & Span <sup>(5)</sup>	--	±0.1	±0.3	%FSS
Response time (10% to 90%) <sup>(6)</sup>	--	0.1	--	ms
Common Mode Voltage (Voltage Version "K") <sup>(9)</sup>	.05	1.25	2.0	Vdc
Input impedance	8.0	25	50	kΩ
Output impedance	3.0	4.5	6.0	kΩ

**Specification Notes:**

**Note 1:** Reference Conditions (unless otherwise noted): Supply,  $V_S=10\text{ Vdc}\pm 0.01\text{ Vdc}$ ;  $T_a=25^\circ\text{C}$ .

**Note 2:** Span is the algebraic difference between the output voltage at full scale pressure and the output at zero pressure. Full Scale Span (FSS) is ratiometric to the supply voltage.

**Note 3:** Linearity is based on best-fit straight line from the zero to the full scale pressure. Hysteresis is the maximum output difference at any point within the operating pressure range for increasing and decreasing pressure.

**Note 4:** Maximum error band of the offset voltage or span over the compensated temperature range, relative to the 25°C reading.

**Note 5:** Long term stability over a six month period.

**Note 6:** Response time for a step change from the zero pressure to the full scale pressure.

**Note 7:** The maximum pressure that can be applied without changing the transducer's performance or accuracy.

**Note 8:** The maximum pressure that can be applied to a transducer without rupture of either the sensing element or transducer case.

**Note 9:** Common Mode Voltage as measured from output to ground.

Physical Dimensions

Package "4" 1/8 NPT Port  
Version B (Bayonet Connector)

File: SS60158

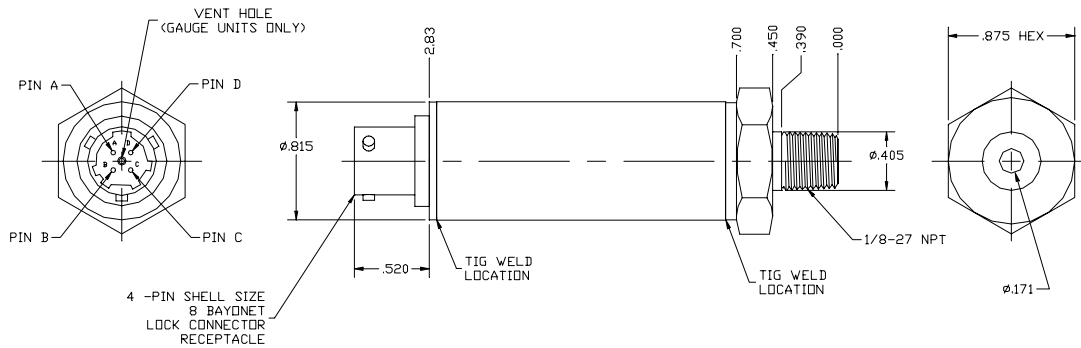

PIN DESIGNATIONS	
PIN LTR	mV Option
A	+IN
B	+OUT
C	-OUT
D	-IN

Version W (Pigtail Cable Connection)

File: SS60159

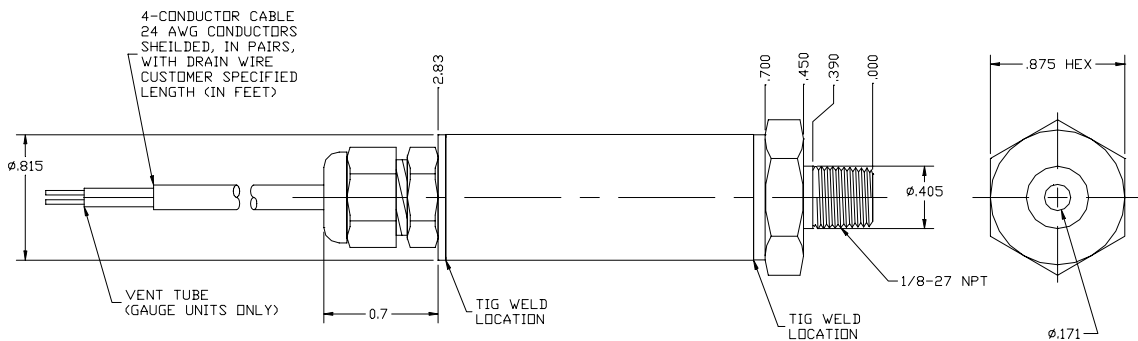

WIRE CODE	
Color	mV Option
RED	+IN
BLACK	-IN
GREEN	+OUT
WHITE	-OUT
BARE	SHIELD

Physical Dimensions

Package "5" 1/4 NPT Port  
Version B (Bayonet Connector)

File: SS60160

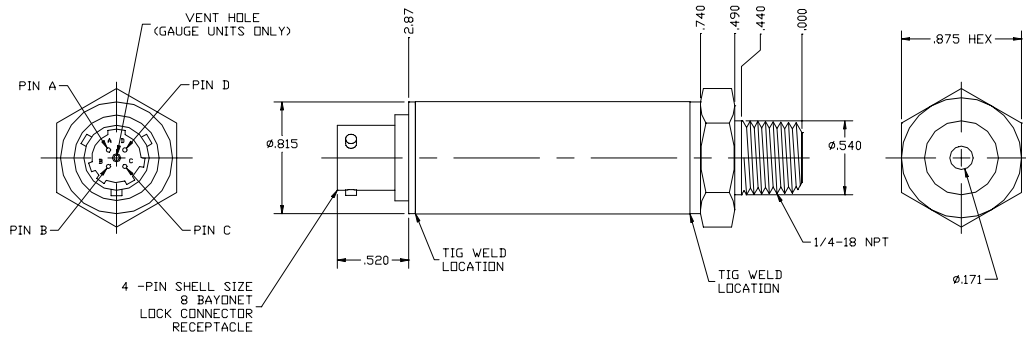

PIN DESIGNATIONS	
PIN LTR	mV Option
A	+IN
B	+OUT
C	-OUT
D	-IN

Version W (Pigtail Cable Connection)

File: SS60161

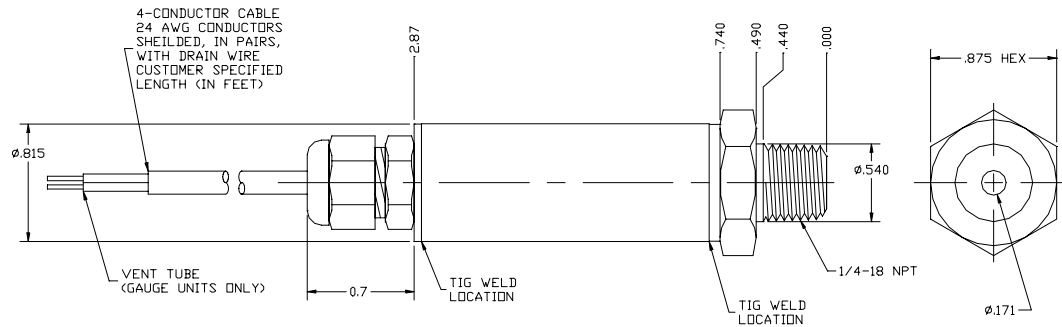

WIRE CODE	
Color	mV Option
RED	+IN
BLACK	-IN
GREEN	+OUT
WHITE	-OUT
BARE	SHIELD

Physical Dimensions

Package "6" 7/16-20 UNF Port  
Version B (Bayonet Connector)

File: SS60162

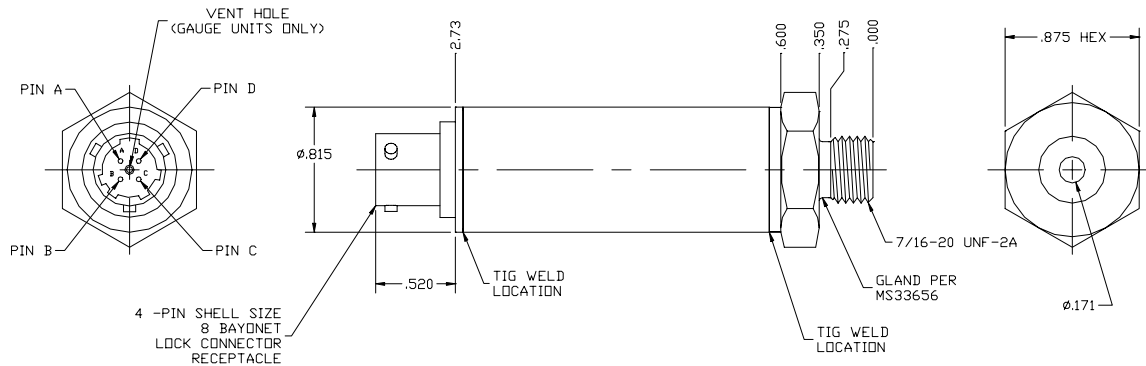

PIN DESIGNATIONS	
PIN LTR	mV Option
A	+IN
B	+OUT
C	-OUT
D	-IN

Version W (Pigtail Cable Connection)

File: SS60163

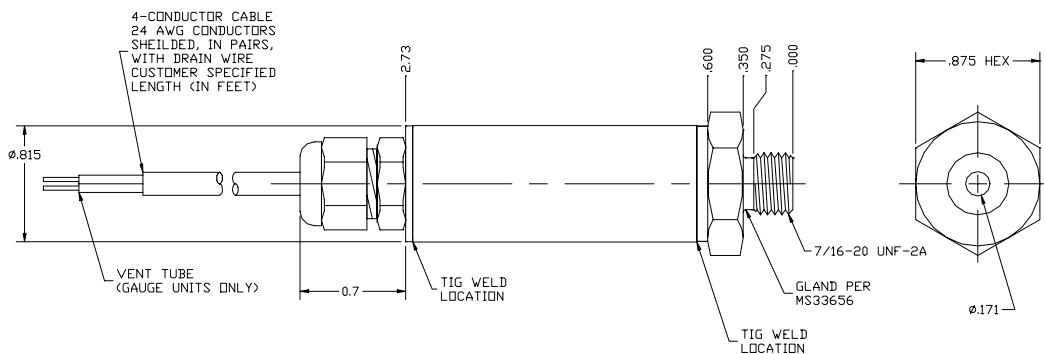

WIRE CODE	
Color	mV Option
RED	+IN
BLACK	-IN
GREEN	+OUT
WHITE	-OUT
BARE	SHIELD

Physical Dimensions

Package "7" 1/4-19 BSPP Port  
Version B (Bayonet Connector)

File: SS60164

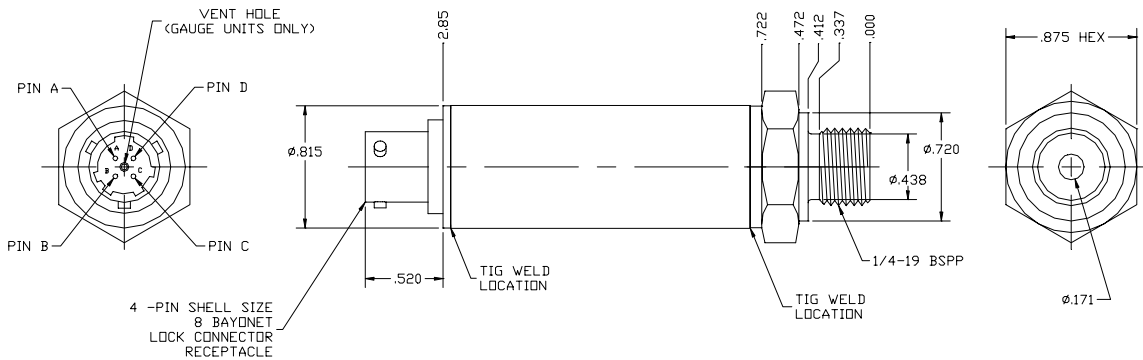

PIN DESIGNATIONS	
PIN LTR	mV Option
A	+IN
B	+OUT
C	-OUT
D	-IN

Version W (Pigtail Cable Connection)

File: SS60165

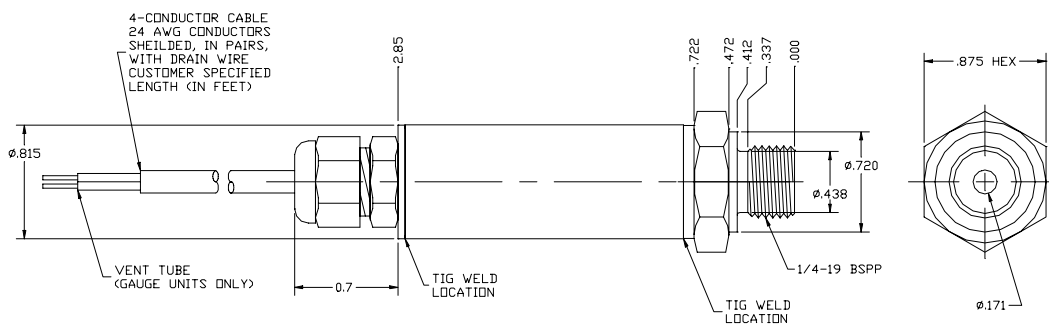

WIRE CODE	
Color	mV Option
RED	+IN
BLACK	-IN
GREEN	+OUT
WHITE	-OUT
BARE	SHIELD

Physical Dimensions

Package "9" VCR Port  
Version B (Bayonet Connector)

File: SS60166

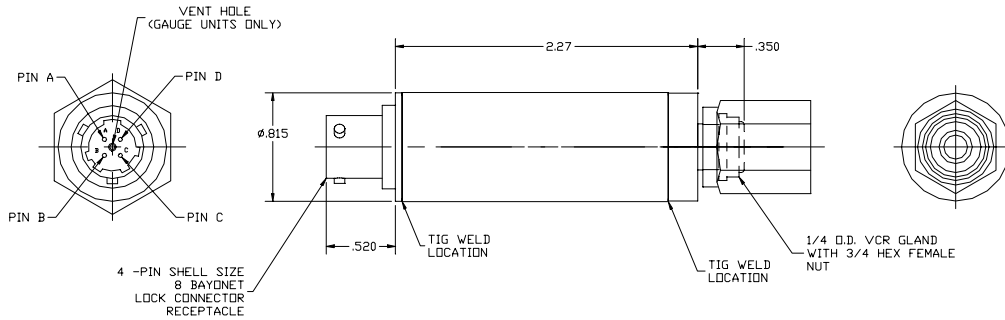

PIN DESIGNATIONS	
PIN LTR	mV Option
A	+IN
B	+OUT
C	-OUT
D	-IN

Version W (Pigtail Cable Connection)

File: SS60167

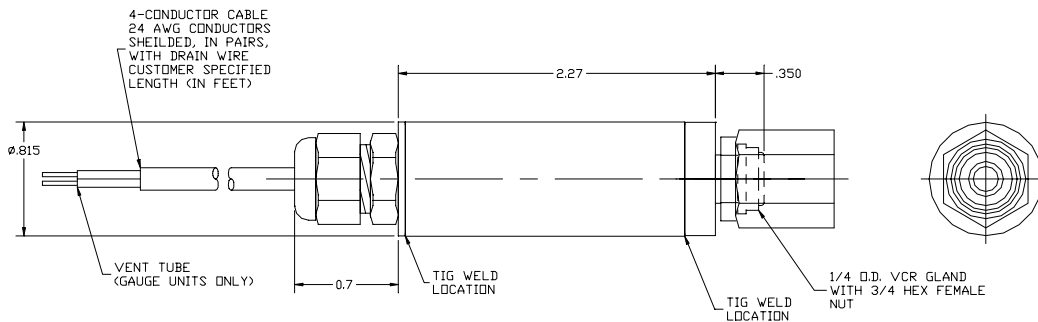

WIRE CODE	
Color	mV Option
RED	+IN
BLACK	-IN
GREEN	+OUT
WHITE	-OUT
BARE	SHIELD

SenSym reserves the right to make changes to any products herein. SenSym does not assume any liability arising out of the application or use of any product or circuit described herein, neither does it convey any license under its patent rights nor the rights of others.

SenSym/ICT  
1804 McCarthy Boulevard  
Milpitas, CA 95035

Tel: (408) 954-6700  
Fax: (408) 954-9458  
Internet: www.sensym.com