

FEATURES

256K x 16 MRAM Memory

- Fast 35 ns Read/Write Cycle
- SRAM Compatible Timing, Uses Existing SRAM Controllers Without Redesign
- Unlimited Read & Write Endurance
- Data Non-volatile for >20-years at Temperature
- One Memory Replaces Flash, SRAM, EEPROM and BBSRAM in System for Simpler, More Efficient Design
- Replace battery-backed SRAM solutions with MRAM to improve reliability
- 3.3 Volt Power Supply
- Automatic Data Protection on Power Loss
- Commercial, Industrial, Extended Temperatures
- **RoHS-Compliant** SRAM TSOPII Package
- **RoHS-Compliant** SRAM BGA Package Shrinks Board Area By Three Times

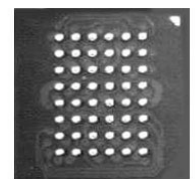
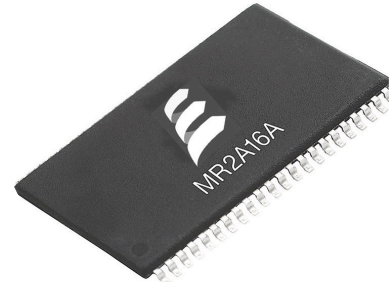

INTRODUCTION

The **MR2A16A** is a 4,194,304-bit magnetoresistive random access memory (MRAM) device organized as 262,144 words of 16 bits. The **MR2A16A** offers SRAM compatible 35 ns read/write timing with unlimited endurance. Data is always non-volatile for greater than 20-years. Data is automatically protected on power loss by low-voltage inhibit circuitry to prevent writes with voltage out of specification. The **MR2A16A** is the ideal memory solution for applications that must permanently store and retrieve critical data and programs quickly.



The **MR2A16A** is available in small footprint 400-mil, 44-lead plastic small-outline TSOP type-II package or 8 mm x 8 mm, 48-pin ball grid array (BGA) package with 0.75 mm ball centers. These packages are compatible with similar low-power SRAM products and other non-volatile RAM products.

The **MR2A16A** provides highly reliable data storage over a wide range of temperatures. The product is offered with commercial temperature (0 to +70 °C), industrial temperature (-40 to +85 °C), and extended temperature (-40 to +105 °C) range options.

CONTENTS

1. DEVICE PIN ASSIGNMENT.....	2
2. ELECTRICAL SPECIFICATIONS.....	4
3. TIMING SPECIFICATIONS.....	7
4. ORDERING INFORMATION.....	12
5. MECHANICAL DRAWING.....	13
6. REVISION HISTORY.....	15
How to Reach Us.....	15

1. DEVICE PIN ASSIGNMENT

Figure 1.1 Block Diagram

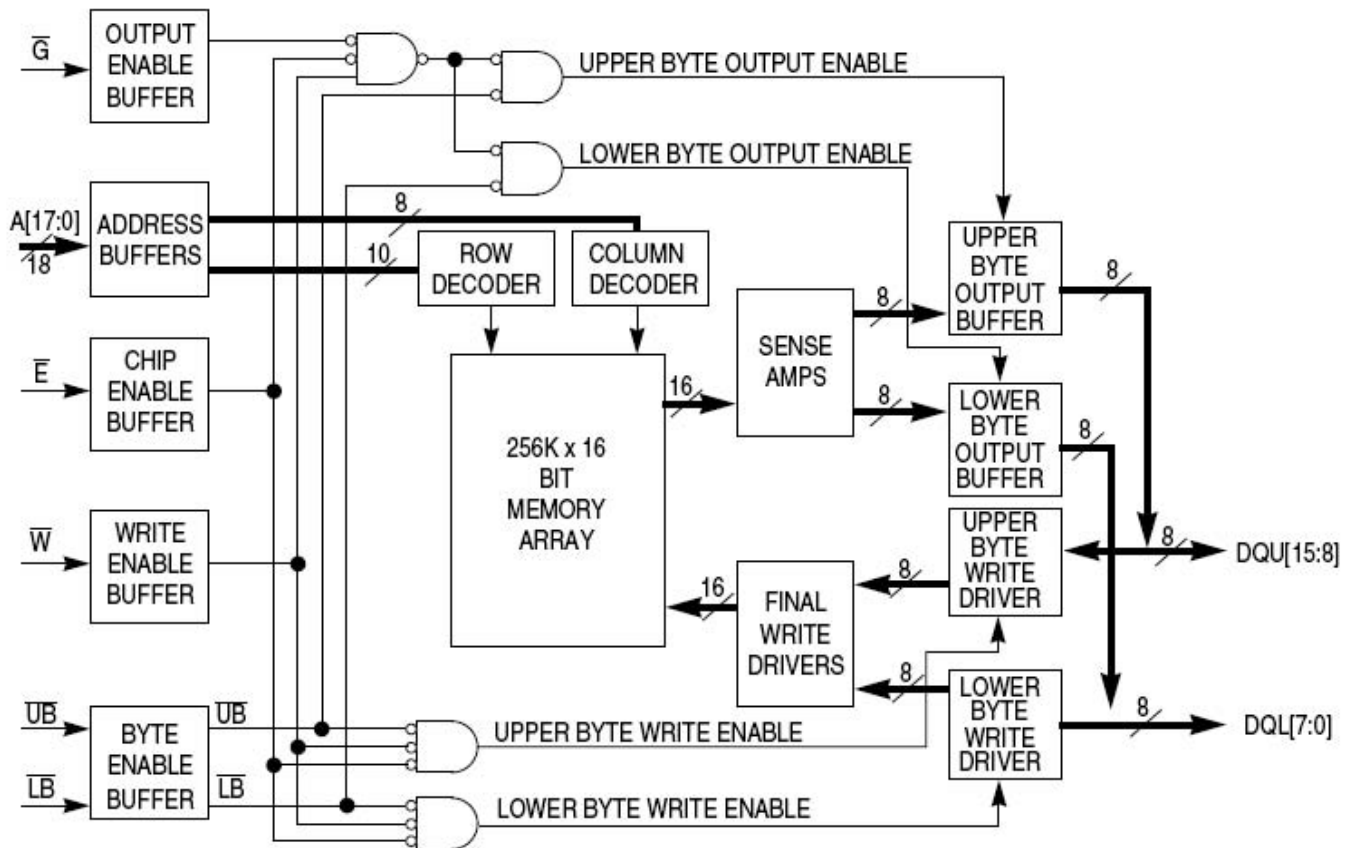
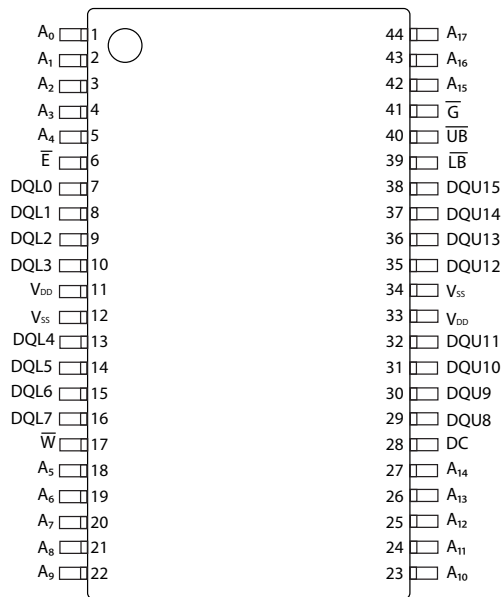

Table 1.1 Pin Functions

Signal Name	Function
A	Address Input
\bar{E}	Chip Enable
\bar{W}	Write Enable
\bar{G}	Output Enable
DQ	Data I/O
V_{DD}	Power Supply
V_{SS}	Ground
DC	Do Not Connect
NC	No Connection

Figure 1.2 Pin Diagrams for Available Packages (Top View)



44-Pin TSOP Type II

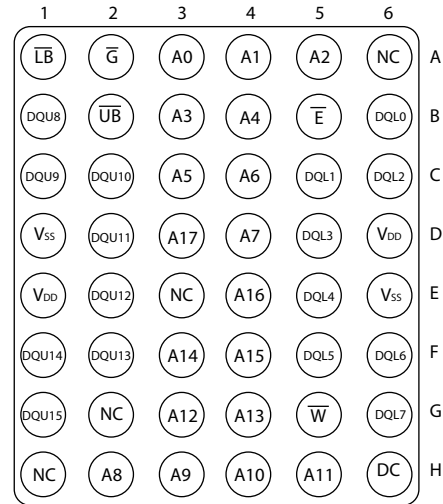

48-Pin BGA

Table 1.2 Operating Modes

\overline{E}^1	\overline{G}^1	\overline{W}^1	\overline{LB}^1	\overline{UB}^1	Mode	V_{DD} Current	DQL[7:0] ²	DQU[15:8] ²
H	X	X	X	X	Not selected	I_{SB1}, I_{SB2}	Hi-Z	Hi-Z
L	H	H	X	X	Output disabled	I_{DDR}	Hi-Z	Hi-Z
L	X	X	H	H	Output disabled	I_{DDR}	Hi-Z	Hi-Z
L	L	H	L	H	Lower Byte Read	I_{DDR}	D_{Out}	Hi-Z
L	L	H	H	L	Upper Byte Read	I_{DDR}	Hi-Z	D_{Out}
L	L	H	L	L	Word Read	I_{DDR}	D_{Out}	D_{Out}
L	X	L	L	H	Lower Byte Write	I_{DDW}	D_{in}	Hi-Z
L	X	L	H	L	Upper Byte Write	I_{DDW}	Hi-Z	D_{in}
L	X	L	L	L	Word Write	I_{DDW}	D_{in}	D_{in}

¹ H = high, L = low, X = don't care

² Hi-Z = high impedance

2. ELECTRICAL SPECIFICATIONS

Absolute Maximum Ratings

This device contains circuitry to protect the inputs against damage caused by high static voltages or electric fields; however, it is advised that normal precautions be taken to avoid application of any voltage greater than maximum rated voltages to these high-impedance (Hi-Z) circuits.

The device also contains protection against external magnetic fields. Precautions should be taken to avoid application of any magnetic field more intense than the maximum field intensity specified in the maximum ratings.

Table 2.1 Absolute Maximum Ratings¹

Parameter	Symbol	Value	Unit
Supply voltage ²	V_{DD}	-0.5 to 4.0	V
Voltage on an pin ²	V_{IN}	-0.5 to $V_{DD} + 0.5$	V
Output current per pin	I_{OUT}	± 20	mA
Package power dissipation	P_D	0.600	W
Temperature under bias MR2A16A (Commercial) MR2A16AC (Industrial) MR2A16AV (Extended)	T_{BIAS}	-10 to 85 -45 to 95 -45 to 110	°C
Storage Temperature	T_{stg}	-55 to 150	°C
Lead temperature during solder (3 minute max)	T_{Lead}	260	°C
Maximum magnetic field during write MR2A16A (All Temperatures)	H_{max_write}	2000	A/m
Maximum magnetic field during read or standby	H_{max_read}	8000	A/m

¹ Permanent device damage may occur if absolute maximum ratings are exceeded. Functional operation should be restricted to recommended operating conditions. Exposure to excessive voltages or magnetic fields could affect device reliability.

² All voltages are referenced to V_{SS} .

³ Power dissipation capability depends on package characteristics and use environment.

Table 2.2 Operating Conditions

Parameter	Symbol	Value	Typical	Max	Unit
Power supply voltage	V_{DD}	3.0 ⁱ	3.3	3.6	V
Write inhibit voltage	V_{WI}	2.5	2.7	3.0 ⁱ	V
Input high voltage	V_{IH}	2.2	-	$V_{DD} + 0.3$ ⁱⁱ	V
Input low voltage	V_{IL}	-0.5 ⁱⁱⁱ	-	0.8	V
Temperature under bias MR2A16A (Commercial) MR2A16AC (Industrial) MR2A16AV (Extended)	T_A	0 -40 -40		70 85 105	°C

ⁱ There is a 2 ms startup time once V_{DD} exceeds $V_{DD}(max)$. See **Power Up and Power Down Sequencing** below.

ⁱⁱ $V_{IH}(max) = V_{DD} + 0.3 V_{DC}$; $V_{IH}(max) = V_{DD} + 2.0 V_{AC}$ (pulse width ≤ 10 ns) for $I \leq 20.0$ mA.

ⁱⁱⁱ $V_{IL}(min) = -0.5 V_{DC}$; $V_{IL}(min) = -2.0 V_{AC}$ (pulse width ≤ 10 ns) for $I \leq 20.0$ mA.

Power Up and Power Down Sequencing

MRAM is protected from write operations whenever V_{DD} is less than V_{WI} . As soon as V_{DD} exceeds $V_{DD}(min)$, there is a startup time of 2 ms before read or write operations can start. This time allows memory power supplies to stabilize.

The \overline{E} and \overline{W} control signals should track V_{DD} on power up to $V_{DD} - 0.2$ V or V_{IH} (whichever is lower) and remain high for the startup time. In most systems, this means that these signals should be pulled up with a resistor so that signal remains high if the driving signal is Hi-Z during power up. Any logic that drives \overline{E} and \overline{W} should hold the signals high with a power-on reset signal for longer than the startup time.

During power loss or brownout where V_{DD} goes below V_{WI} , writes are protected and a startup time must be observed when power returns above $V_{DD}(min)$.

Figure 2.1 Power Up and Power Down Diagram

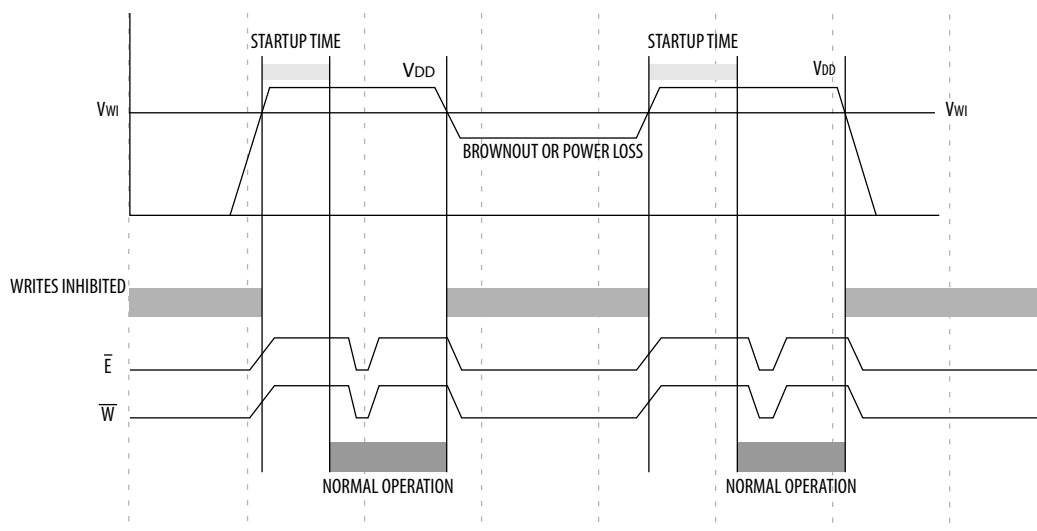

Table 2.3 DC Characteristics

Parameter	Symbol	Min	Typical	Max	Unit
Input leakage current	$I_{\text{kg}(I)}$	-	-	± 1	μA
Output leakage current	$I_{\text{kg}(O)}$	-	-	± 1	μA
Output low voltage ($I_{\text{OL}} = +4 \text{ mA}$) ($I_{\text{OL}} = +100 \mu\text{A}$)	V_{OL}	-	-	0.4 $V_{\text{SS}} + 0.2$	V
Output high voltage ($I_{\text{OH}} = -4 \text{ mA}$) ($I_{\text{OH}} = -100 \mu\text{A}$)	V_{OH}	2.4 $V_{\text{DD}} - 0.2$	-	-	V

Table 2.4 Power Supply Characteristics

Parameter	Symbol	Typical	Max	Unit
AC active supply current - read modes ¹ ($I_{\text{OUT}} = 0 \text{ mA}$, $V_{\text{DD}} = \text{max}$)	I_{DDR}	55	80	mA
AC active supply current - write modes ¹ ($V_{\text{DD}} = \text{max}$) MR2A16A (Commercial) MR2A16AC (Industrial) MR2A16AV (Extended)	I_{DDW}	105 105 105	155 165 165	mA
AC standby current ($V_{\text{DD}} = \text{max}$, $\bar{E} = V_{\text{IH}}$) <i>no other restrictions on other inputs</i>	I_{SB1}	18	28	mA
CMOS standby current ($\bar{E} \geq V_{\text{DD}} - 0.2 \text{ V}$ and $V_{\text{In}} \leq V_{\text{SS}} + 0.2 \text{ V}$ or $\geq V_{\text{DD}} - 0.2 \text{ V}$) ($V_{\text{DD}} = \text{max}$, $f = 0 \text{ MHz}$)	I_{SB2}	9	12	mA

¹ All active current measurements are measured with one address transition per cycle and at minimum cycle time.

3. TIMING SPECIFICATIONS

Table 3.1 Capacitance¹

Parameter	Symbol	Typical	Max	Unit
Address input capacitance	C_{In}	-	6	pF
Control input capacitance	C_{In}	-	6	pF
Input/Output capacitance	$C_{I/O}$	-	8	pF

¹ $f = 1.0 \text{ MHz}$, $dV = 3.0 \text{ V}$, $T_A = 25 \text{ }^\circ\text{C}$, periodically sampled rather than 100% tested.

Table 3.2 AC Measurement Conditions

Parameter	Value	Unit
Logic input timing measurement reference level	1.5	V
Logic output timing measurement reference level	1.5	V
Logic input pulse levels	0 or 3.0	V
Input rise/fall time	2	ns
Output load for low and high impedance parameters	See Figure 3.1	
Output load for all other timing parameters	See Figure 3.2	

Figure 3.1 Output Load Test Low and High

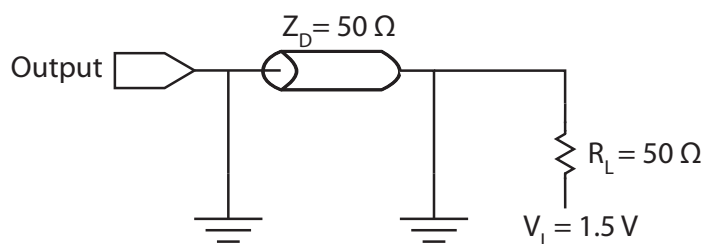
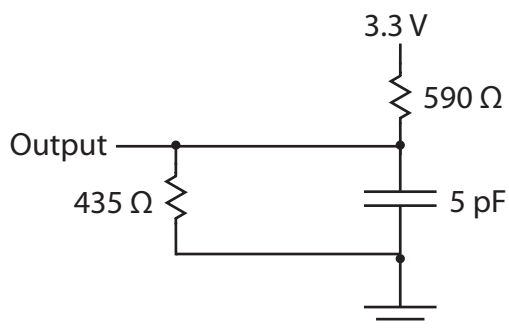

Figure 3.2 Output Load Test All Others



Read Mode

Table 3.3 Read Cycle Timing¹

Parameter	Symbol	Min	Max	Unit
Read cycle time	t_{AVAV}	35	-	ns
Address access time	t_{AVQV}	-	35	ns
Enable access time ²	t_{ELOV}	-	35	ns
Output enable access time	t_{GLOV}	-	15	ns
Byte enable access time	t_{BLOV}	-	15	ns
Output hold from address change	t_{AXQX}	3	-	ns
Enable low to output active ³	t_{ELOX}	3	-	ns
Output enable low to output active ³	t_{GLOX}	0	-	ns
Byte enable low to output active ³	t_{BLOX}	0	-	ns
Enable high to output Hi-Z ³	t_{EHOZ}	0	15	ns
Output enable high to output Hi-Z ³	t_{GHOZ}	0	10	ns
Byte high to output Hi-Z ³	t_{BHOZ}	0	10	ns

¹ \overline{W} is high for read cycle. Power supplies must be properly grounded and decoupled, and bus contention conditions must be minimized or eliminated during read or write cycles.

² Addresses valid before or at the same time \overline{E} goes low.

³ This parameter is sampled and not 100% tested. Transition is measured ± 200 mV from the steady-state voltage.

Figure 3.3A Read Cycle 1

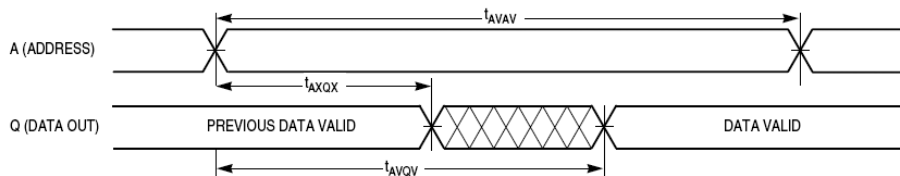

NOTES:
Device is continuously selected ($\overline{E} \leq V_{IL}$, $\overline{G} \leq V_{IL}$).

Figure 3.3B Read Cycle 2

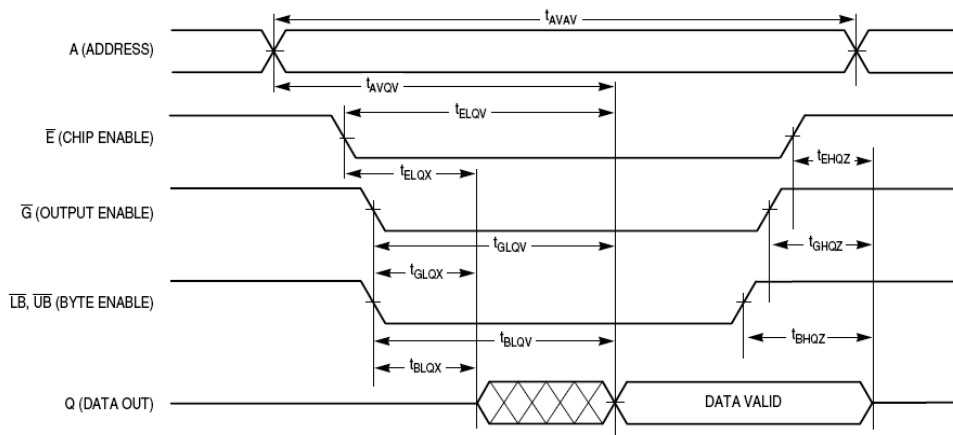

Table 3.4 Write Cycle Timing 1 (\overline{W} Controlled)¹

Parameter	Symbol	Min	Max	Unit
Write cycle time ²	t_{AVAV}	35	-	ns
Address set-up time	t_{AVWL}	0	-	ns
Address valid to end of write (\overline{G} high)	t_{AVWH}	18	-	ns
Address valid to end of write (\overline{G} low)	t_{AVWH}	20	-	ns
Write pulse width (\overline{G} high)	t_{WLWH} t_{WLEH}	15	-	ns
Write pulse width (\overline{G} low)	t_{WLWH} t_{WLEH}	15	-	ns
Data valid to end of write	t_{DVWH}	10	-	ns
Data hold time	t_{WHDX}	0	-	ns
Write low to data Hi-Z ³	t_{WLQZ}	0	12	ns
Write high to output active ³	t_{WHQX}	3	-	ns
Write recovery time	t_{WHAX}	12	-	ns

¹ All write occurs during the overlap of \overline{E} low and \overline{W} low. Power supplies must be properly grounded and decoupled and bus contention conditions must be minimized or eliminated during read and write cycles. If \overline{G} goes low at the same time or after \overline{W} goes low, the output will remain in a high impedance state. After \overline{W} , \overline{E} or $\overline{UB}/\overline{LB}$ has been brought high, the signal must remain in steady-state high for a minimum of 2 ns. The minimum time between \overline{E} being asserted low in one cycle to \overline{E} being asserted low in a subsequent cycle is the same as the minimum cycle time allowed for the device.

² All write cycle timings are referenced from the last valid address to the first transition address.

³ This parameter is sampled and not 100% tested. Transition is measured ± 200 mV from the steady-state voltage. At any given voltage or temperature, $t_{WLQZ}(\max) < t_{WHQX}(\min)$

Figure 3.4 Write Cycle Timing 1 (\overline{W} Controlled)

Table 3.5 Write Cycle Timing 2 (\bar{E} Controlled)¹

Parameter	Symbol	Min	Max	Unit
Write cycle time ²	t_{AVAV}	35	-	ns
Address set-up time	t_{AVEL}	0	-	ns
Address valid to end of write (\bar{G} high)	t_{AVEH}	18	-	ns
Address valid to end of write (\bar{G} low)	t_{AVEH}	20	-	ns
Enable to end of write (\bar{G} high)	t_{ELEH} t_{ELWH}	15	-	ns
Enable to end of write (\bar{G} low) ³	t_{ELEH} t_{ELWH}	15	-	ns
Data valid to end of write	t_{DVEH}	10	-	ns
Data hold time	t_{EHDX}	0	-	ns
Write recovery time	t_{EHAX}	12	-	ns

¹ All write occurs during the overlap of \bar{E} low and \bar{W} low. Power supplies must be properly grounded and decoupled and bus contention conditions must be minimized or eliminated during read and write cycles. If \bar{G} goes low at the same time or after \bar{W} goes low, the output will remain in a high impedance state. After \bar{W} , \bar{E} or \bar{UB}/\bar{LB} has been brought high, the signal must remain in steady-state high for a minimum of 2 ns. The minimum time between \bar{E} being asserted low in one cycle to \bar{E} being asserted low in a subsequent cycle is the same as the minimum cycle time allowed for the device.

² All write cycle timings are referenced from the last valid address to the first transition address.

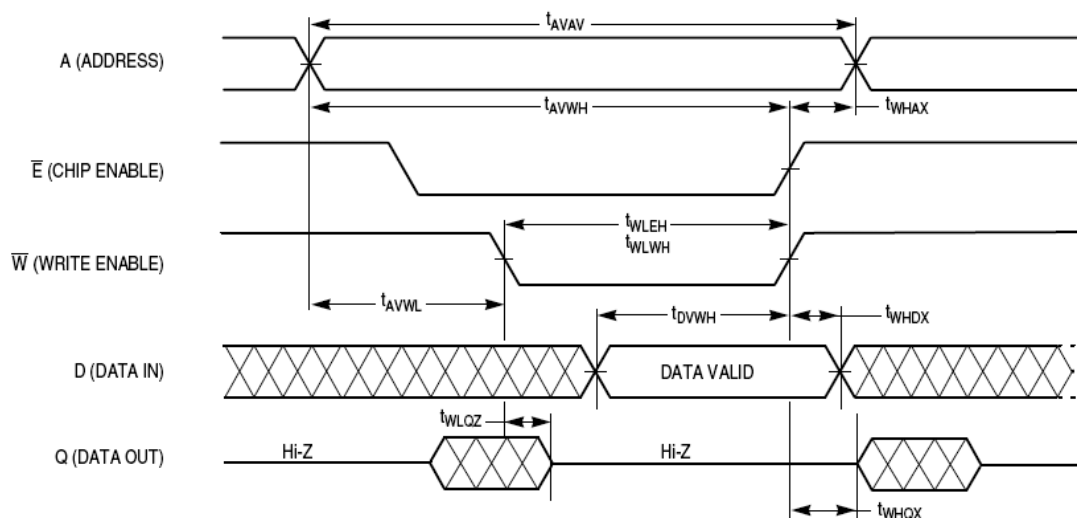
³ If \bar{E} goes low at the same time or after \bar{W} goes low, the output will remain in a high-impedance state. If \bar{E} goes high at the same time or before \bar{W} goes high, the output will remain in a high-impedance state.

Figure 3.5 Write Cycle Timing 2 (\bar{E} Controlled)¹

Table 3.6 Write Cycle Timing 3 ($\overline{\text{LB}}/\overline{\text{UB}}$ Controlled)¹

Parameter	Symbol	Min	Max	Unit
Write cycle time ²	t_{AVAV}	35	-	ns
Address set-up time	t_{AVBL}	0	-	ns
Address valid to end of write ($\overline{\text{G}}$ high)	t_{AVBH}	18	-	ns
Address valid to end of write ($\overline{\text{G}}$ low)	t_{AVBH}	20	-	ns
Write pulse width ($\overline{\text{G}}$ high)	t_{BLEH} t_{BLWH}	15	-	ns
Write pulse width ($\overline{\text{G}}$ low)	t_{BLEH} t_{BLWH}	15	-	ns
Data valid to end of write	t_{DVBH}	10	-	ns
Data hold time	t_{BHDX}	0	-	ns
Write recovery time	t_{BHAX}	12	-	ns

¹ All write occurs during the overlap of $\overline{\text{E}}$ low and $\overline{\text{W}}$ low. Power supplies must be properly grounded and decoupled and bus contention conditions must be minimized or eliminated during read and write cycles. If $\overline{\text{G}}$ goes low at the same time or after $\overline{\text{W}}$ goes low, the output will remain in a high impedance state. After $\overline{\text{W}}$, $\overline{\text{E}}$ or $\overline{\text{UB}}/\overline{\text{LB}}$ has been brought high, the signal must remain in steady-state high for a minimum of 2 ns. If both byte control signals are asserted, the two signals must have no more than 2 ns skew between them. The minimum time between $\overline{\text{E}}$ being asserted low in one cycle to $\overline{\text{E}}$ being asserted low in a subsequent cycle is the same as the minimum cycle time allowed for the device.

² All write cycle timings are referenced from the last valid address to the first transition address.

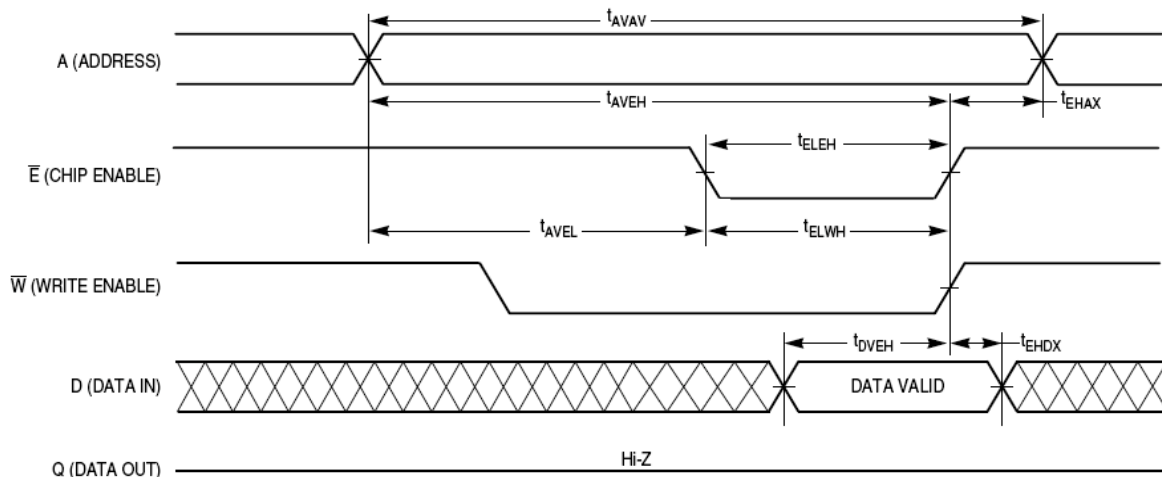
Table 3.6 Write Cycle Timing 3 ($\overline{\text{UB}}/\overline{\text{LB}}$ Controlled)

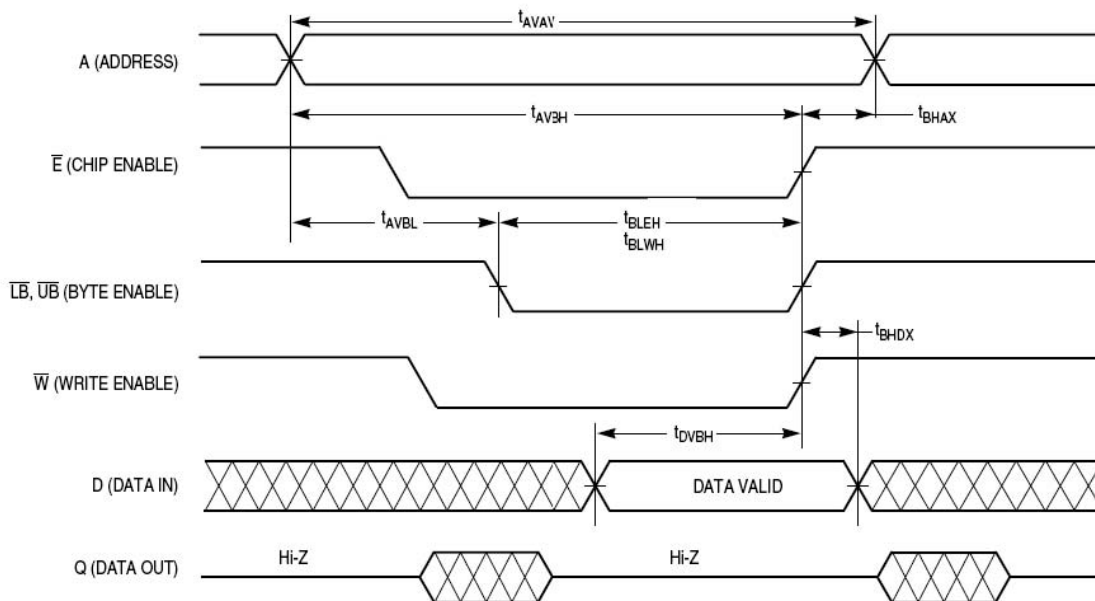

4. ORDERING INFORMATION

Figure 4.1 Part Numbering System

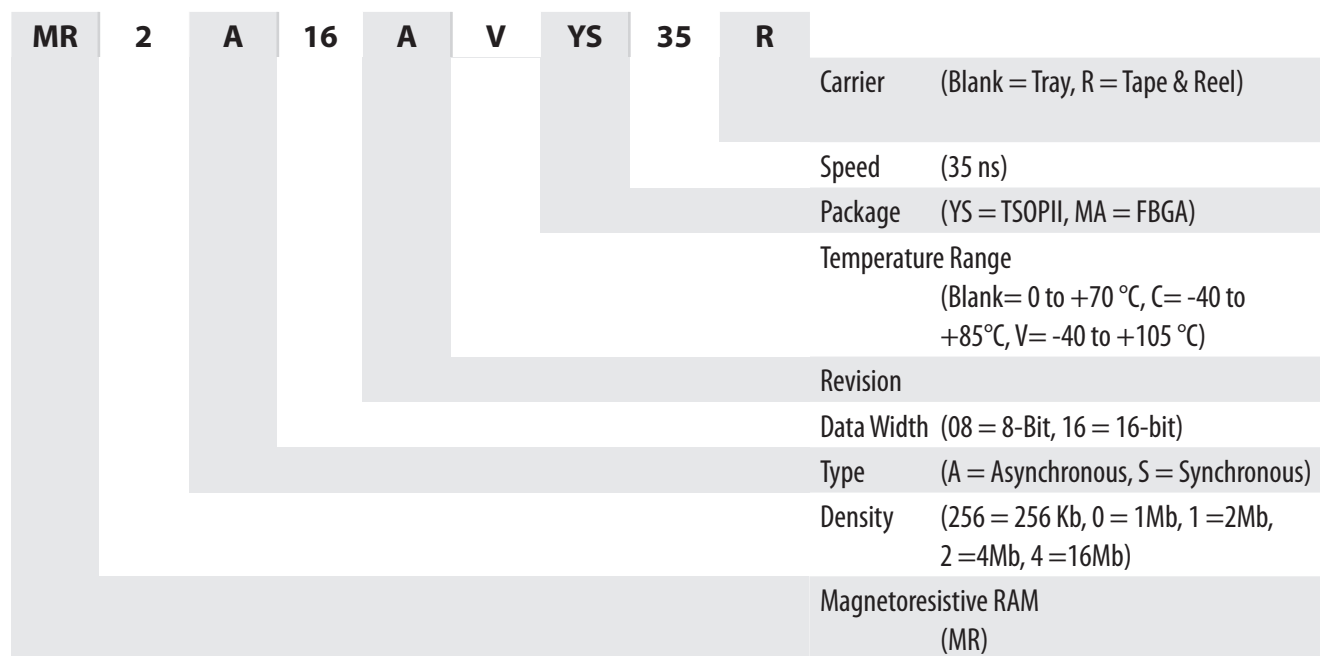
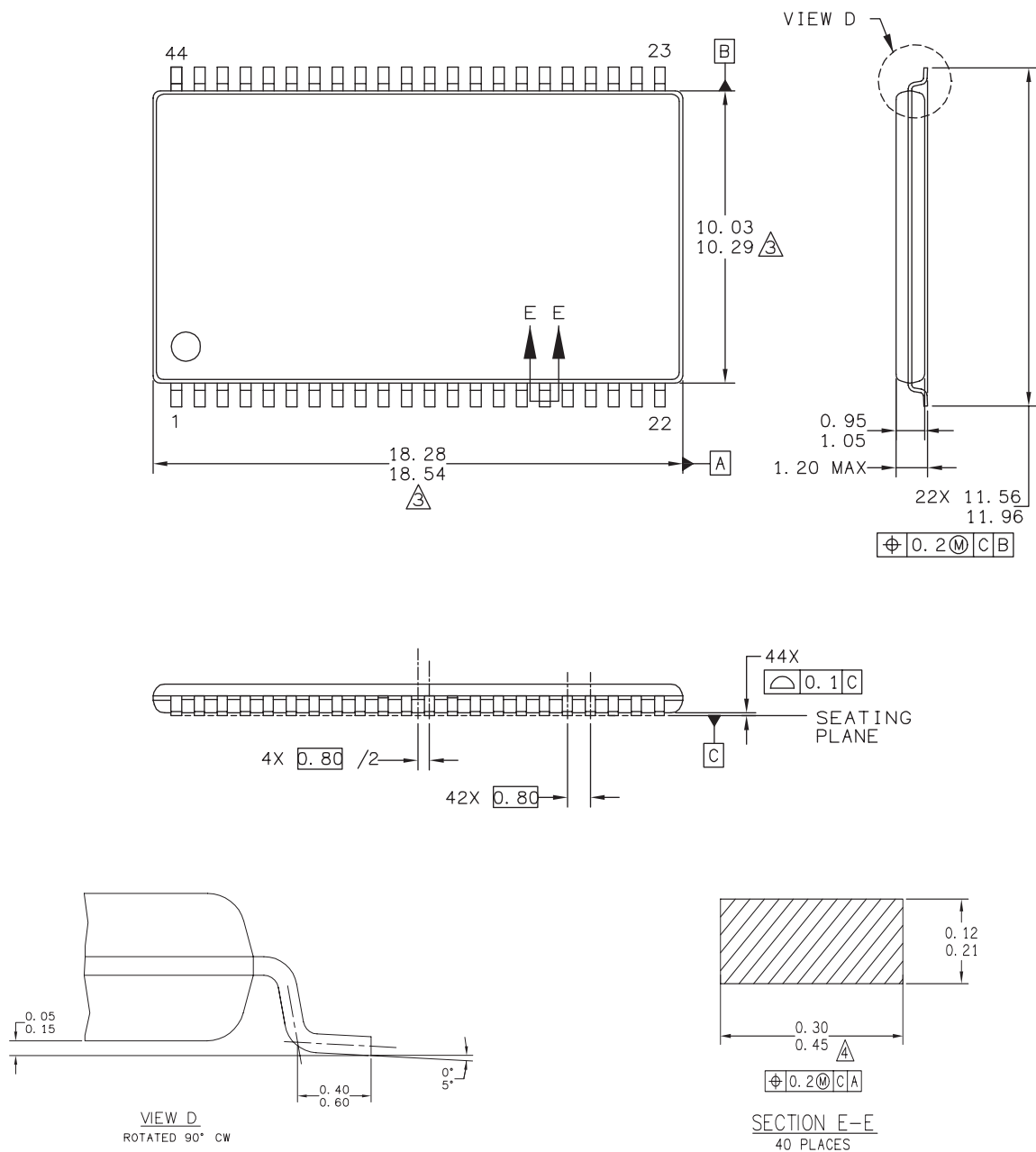

Table 4.1 Available Parts

Part Number	Description	Temperature
MR2A16AYS35	3.3 V 256Kx16 MRAM 44-TSOP	Commercial
MR2A16ACYS35	3.3 V 256Kx16 MRAM 44-TSOP	Industrial
MR2A16AVYS35	3.3 V 256Kx16 MRAM 44-TSOP	Extended
MR2A16AYS35R	3.3 V 256Kx16 MRAM 44-TSOP T&R	Commercial
MR2A16ACYS35R	3.3 V 256Kx16 MRAM 44-TSOP T&R	Industrial
MR2A16AVYS35R	3.3 V 256Kx16 MRAM 44-TSOP T&R	Extended
MR2A16AMA35	3.3 V 256Kx16 MRAM 48-BGA	Commercial
MR2A16ACMA35	3.3 V 256Kx16 MRAM 48-BGA	Industrial
MR2A16AVMA35	3.3 V 256Kx16 MRAM 48-BGA	Extended

5. MECHANICAL DRAWING

Figure 5.1 44-TSOP



Print Version Not To Scale

1. Dimensions and tolerances per ASME Y14.5M - 1994.
2. Dimensions in Millimeters.
3. Dimensions do not include mold protrusion.
4. Dimension does not include DAM bar protrusions.
DAM Bar protrusion shall not cause the lead width to exceed 0.58.

Figure 5.2 48-FBGA

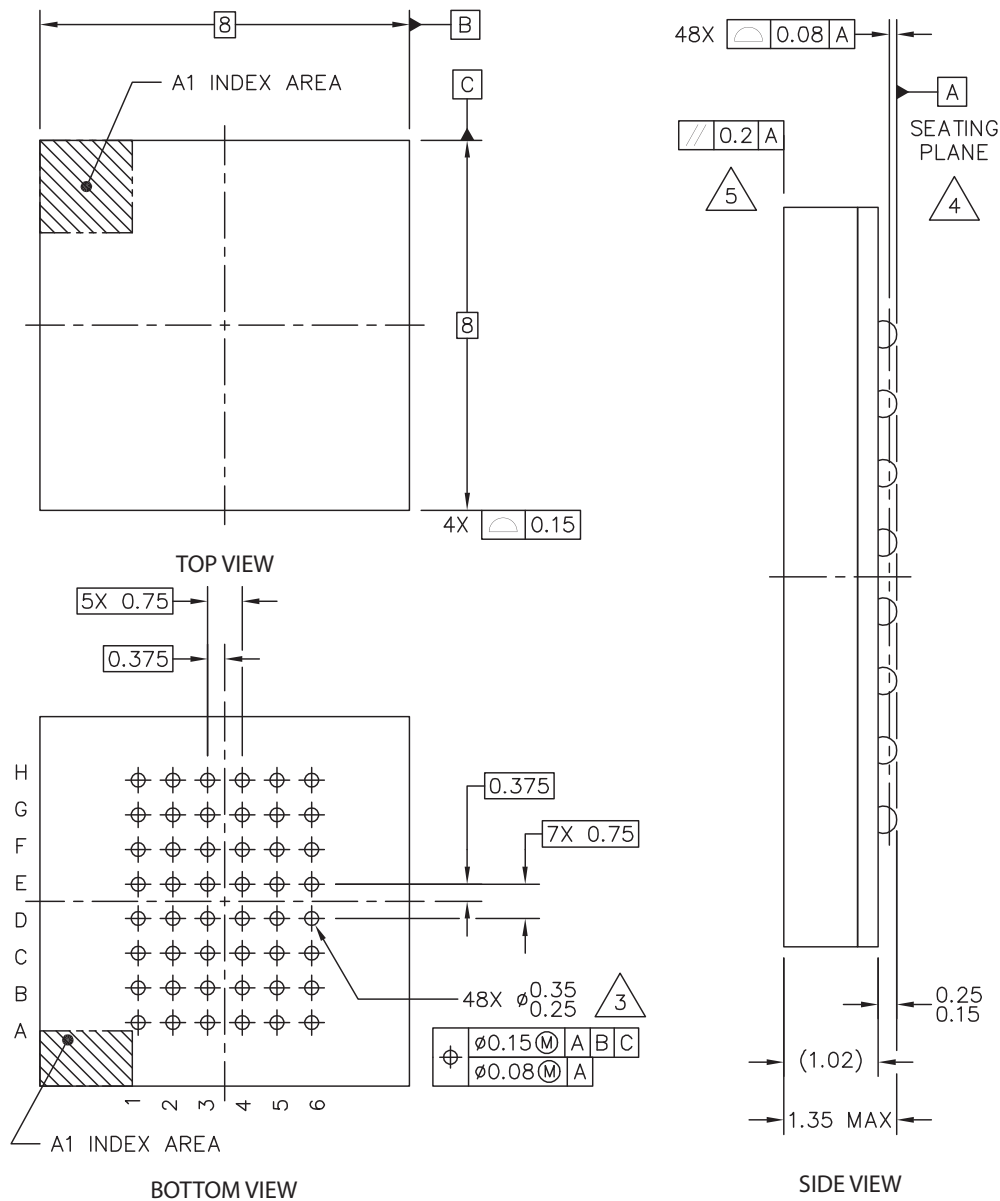

Print Version Not To Scale

1. Dimensions in Millimeters.
2. Dimensions and tolerances per ASME Y14.5M - 1994.
3. Maximum solder ball diameter measured parallel to DATUM A
4. DATUM A, the seating plane is determined by the spherical crowns of the solder balls.
5. Parallelism measurement shall exclude any effect of mark on top surface of package.

6. REVISION HISTORY

Revision	Date	Description of Change
4	Jun 18, 2007	Added new industrial and extended temperature product information; updated part ordering information; changed to 2 ms delay after power up; power supply characteristics values updated to TBD for industrial and extended temperature devices.
5	Sept 21, 2007	Changed MR2A16ATS35C product description to Legacy Commercial. Added the New Commercial temperature product (MR2A16AYS35) information. Table 3: MR2A16AYS35 Hmax-write=25 Oe. Table 4: MR2A16AYS35 has a 2 ms power up waiting period. Table 6: Applied values to TBD's in IDD specifications.
6	Nov 12, 2007	Table 2: Changed IDDA to IDDR or IDDW. Table 13: Added note indicating that TS and YS are both valid package codes. Current Part Numbering System: Added commercial (missing letter) temperature range.
7	Sep 12, 2008	Reformat Datasheet for EverSpin, Add BGA Packaging Information, Add Tape & Reel Part Numbers, Add Power Sequencing Info, Correct IOH spec of VOH to -100 uA, Correct ac Test Conditions.
8	July 22, 2009	Add TSOPII Lead Cross-Section, Add Production Note. Converted to new document format.

Unless Otherwise Noted, This is a Production Product - This product conforms to specifications per the terms of the Everspin standard warranty. The product has completed Everspin internal qualification testing and has reached production status.

How to Reach Us:

Home Page:
www.everspin.com

E-Mail:

support@everspin.com
orders@everspin.com
sales@everspin.com

USA/Asia/Pacific

Everspin Technologies
1300 N. Alma School Road, CH-409
Chandler, Arizona 85224
+1-877-347-MRAM (6726)
+1-480-347-1111

Europe, Middle East and Africa

support.europe@everspin.com
Wokingham, United Kingdom
+44 (0)118 907 6155

Japan

support.japan@everspin.com
Yokohama, Japan
+81 (0) 45-846-6299

Document Control Number:

EST00193_MR2A16A, Revision 8.4, 9/2009

Filename:

EST_MR2A16A_prod.pdf

Information in this document is provided solely to enable system and software implementers to use Everspin Technologies products. There are no express or implied licenses granted hereunder to design or fabricate any integrated circuit or circuits based on the information in this document. Everspin Technologies reserves the right to make changes without further notice to any products herein. Everspin makes no warranty, representation or guarantee regarding the suitability of its products for any particular purpose, nor does Everspin Technologies assume any liability arising out of the application or use of any product or circuit, and specifically disclaims any and all liability, including without limitation consequential or incidental damages. "Typical" parameters, which may be provided in Everspin Technologies data sheets and/or specifications can and do vary in different applications and actual performance may vary over time. All operating parameters including "Typicals" must be validated for each customer application by customer's technical experts. Everspin Technologies does not convey any license under its patent rights nor the rights of others. Everspin Technologies products are not designed, intended, or authorized for use as components in systems intended for surgical implant into the body, or other applications intended to support or sustain life, or for any other application in which the failure of the Everspin Technologies product could create a situation where personal injury or death may occur. Should Buyer purchase or use Everspin Technologies products for any such unintended or unauthorized application, Buyer shall indemnify and hold Everspin Technologies and its officers, employees, subsidiaries, affiliates, and distributors harmless against all claims, costs, damages, and expenses, and reasonable attorney fees arising out of, directly or indirectly, any claim of personal injury or death associated with such unintended or unauthorized use, even if such claim alleges that Everspin Technologies was negligent regarding the design or manufacture of the part. Everspin™ and the Everspin logo are trademarks of Everspin Technologies, Inc. All other product or service names are the property of their respective owners.

©Everspin Technologies, Inc. 2009

