



Converting STK11C48 to STK12C68

Introduction

This document provides guidance on converting a design that is currently using the STK11C48 to the Simtek recommended part STK12C68.

Feature set and limitations of the STK11C48

Function Category	STK11C48	STK12C68
Autostore	Not allowed	Wired to disallow autostore
Software store	Yes	Yes
Software recall	Yes	Yes

Package Comparison

The 600 mil dip package is available in the STK12C68 and the STK11C68.
Other packages that take less PCB area also exist such as 300 mil CDIP/PDIP and the 350 mil SOIC.

Package	PKG Code	STK11C48	STK12C68	Notes
350 mil SOIC – 28 pin	S	Available	Available	Surface mount – smallest PCB area
600 mil pdip -- 28 pin	W	Not available	Available	Through hole
300 mil pdip -- 28 pin	P	Available	Available	Through hole
300 mil cdip -- 28 pin	C	Available	Available	Through hole

Issues to consider during the conversion

The key difference is that the STK11C48 has been internally configured to disable the autostore function and does not use a 68uf capacitor. The STK12C68 will be wired in VCAP power mode to select non-autostore configuration. Also, the new HSB signal is unused. All other pins have the same function. Only software store is used to store the part. Recall is automatic on power up and also may be activated by software sequence.

Schematic changes for conversion:

The key difference is that the STK11C48 is equivalent (but smaller) to an STK12C68 wired in VCAP power mode to select no autostore. To do this, the power must be supplied to the VCAP pin and NOT applied to the VCCx pin (which can be either open or at ground). Also, the bypass capacitor moves to the VCAP pin. The choice of package is open with the "S" package being the most area efficient surface mount choice.

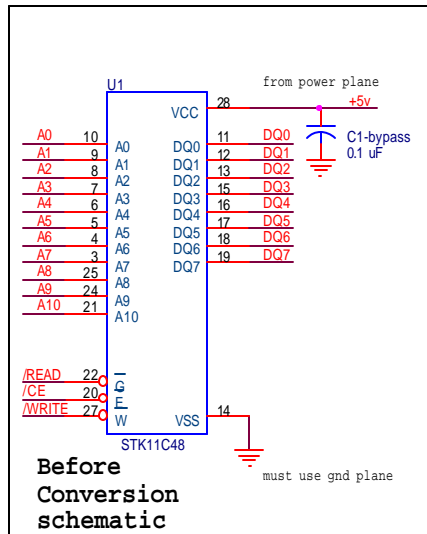

In this conversion, old bypass capacitor C1 is moved from +5v on pin 28 to pin 1. It is essential that pin 28 be left OPEN and system power (+5v) is now connected to pin 1 (VCAP). The new signal /HSB is left open and unused. This will configure the STK12C68 into a non-autostore part. The storage capacitor is not needed since autostores are deselected. Software stores use system power to complete commanded stores. The extra address pins (A11 and A12) are tied inactive to ground.

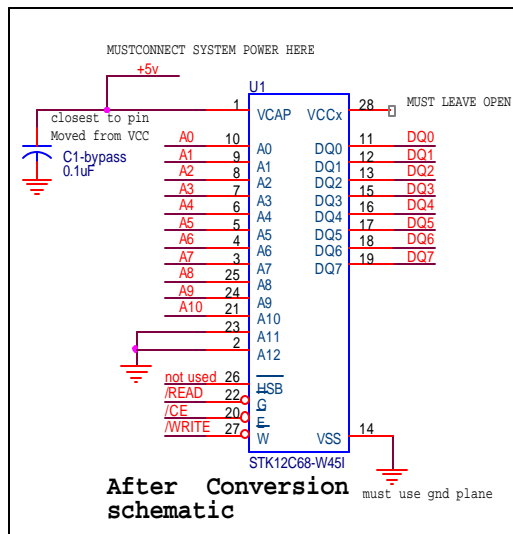

On the next page, pin by pin comparisons of the two show all pins are the same except for the bypass capacitor moving to pin 1 and connected to system power, +5v. Pin 28 must now be unpowered and open.

Corresponding pin Connections

Pin for pin comparison of the two parts is given in the table below:

STK11C48 NAME	STK12C68 NAME	Pin	Comments
NC	VCAP	1	Must connect 0.1UF BYPASS and hook to system power +5v
A12	A12	2	Connect to ground, (unused address)
A7	A7	3	“
A6	A6	4	“
A5	A5	5	“
A4	A4	6	“
A3	A3	7	“
A2	A2	8	“
A1	A1	9	“
A0/	A0	10	“
DQ0	DQ0	11	“
DQ1	DQ1	12	“
DQ2	DQ2	13	“
VSS	VSS	14	“
DQ3	DQ3	15	“
DQ4	DQ4	16	“
DQ5	DQ5	17	“
DQ6	DQ6	18	“
DQ7	DQ7	19	“
E#	E#	20	“
A10	A10	21	“
G#	G#	22	“
A11	A11	23	Connect to ground, (unused address)
A9	A9	24	“
A8	A8	25	“
NC	HSB	26	LEAVE OPEN UNUSED
W#	W#	27	No change
VCC	VCCX	28	This pin now must be OPEN and NOT connected to +5v