

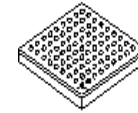

MCIMX25



Package Information

Plastic package
Case 5284 17 x 17 mm, 0.8 mm Pitch
Case 2107 12 x 12 mm, 0.5 mm Pitch

i.MX25 Applications Processor for Consumer and Industrial Products

Silicon Version 1.2

Ordering Information

See [Table 1 on page 3](#) for ordering information.

1 Introduction

The i.MX25 multimedia applications processor has the right mix of high performance, low power, and integration to support the growing needs of the industrial and general embedded markets.

At the core of the i.MX25 is Freescale's fast, proven, power-efficient implementation of the ARM926EJ-S core, with speeds of up to 400 MHz. The i.MX25 includes support for up to 133-MHz DDR2 memory, integrated 10/100 Ethernet MAC, and two on-chip USB PHYs. The device is suitable for a wide range of applications, including the following:

- Graphical remote controls
- Human Machine Interface (HMI)
- Residential and commercial control panels
- Residential gateway (smart metering)
- Handheld scanners and printers

1. Introduction	1
1.1. Ordering Information	3
1.2. Block Diagram	5
2. Features	6
2.1. Special Signal Considerations	9
3. Electrical Characteristics	11
3.1. i.MX25 Chip-Level Conditions	11
3.2. Supply Power-Up/Power-Down Requirements and Restrictions	16
3.3. Power Characteristics	18
3.4. Thermal Characteristics	19
3.5. I/O DC Parameters	20
3.6. AC Electrical Characteristics	25
3.7. Module Timing and Electrical Parameters	42
4. Package Information and Contact Assignment	124
4.1. 400 MAPBGA—Case 17x17 mm, 0.8 mm Pitch	124
4.2. Ground, Power, Sense, and Reference Contact Assignments Case 17x17 mm, 0.8 mm Pitch	125
4.3. Signal Contact Assignments—17 x 17 mm, 0.8 mm Pitch	127
4.4. i.MX25 17x17 Package Ball Map	130
4.5. 347 MAPBGA—Case 12 x 12 mm, 0.5 mm Pitch	133
4.6. Ground, Power, Sense, and Reference Contact Assignments Case 12x12 mm, 0.5 mm Pitch	134
4.7. Signal Contact Assignments—12 x 12 mm, 0.5 mm Pitch	135
4.8. i.MX25 12x12 Package Ball Map	138
5. Revision History	141



- Electronic point-of-sale terminals
- Patient-monitoring devices

Features of the i.MX25 processor include the following:

- **Advanced power management**—The heart of the device is a level of power management throughout the IC that enables the multimedia features and peripherals to achieve minimum system power consumption in active and various low-power modes. Power management techniques allow the designer to deliver a feature-rich product that requires levels of power far lower than typical industry expectations.
- **Multimedia powerhouse**—The multimedia performance of the i.MX25 processor is boosted by a 16 KB L1 instruction and data cache system and further enhanced by an LCD controller (with alpha blending), a CMOS image sensor interface, an A/D controller (integrated touchscreen controller), and a programmable Smart DMA (SDMA) controller.
- **128 Kbytes on-chip SRAM**—The additional 128 Kbyte on-chip SRAM makes the device ideal for eliminating external RAM in applications with small footprint RTOS. The on-chip SRAM allows the designer to enable an ultra low power LCD refresh.
- **Interface flexibility**—The device interface supports connection to all common types of external memories: MobileDDR, DDR, DDR2, NOR Flash, PSRAM, SDRAM and SRAM, NAND Flash, and managed NAND.
- **Increased security**—Because the need for advanced security for tethered and untethered devices continues to increase, the i.MX25 processor delivers hardware-enabled security features that enable secure e-commerce, Digital Rights Management (DRM), information encryption, robust tamper detection, secure boot, and secure software downloads.
- **On-chip PHY**—The device includes an HS USB OTG PHY and FS USB HOST PHY.
- **Fast Ethernet**—For rapid external communication, a Fast Ethernet Controller (FEC) is included.
- i.MX25 only supports Little Endian mode.

1.1 Ordering Information

Table 1 provides ordering information for the i.MX25.

Table 1. Ordering Information¹

Description	Part Number	Silicon Version	Projected Temperature Range (°C)	Package	Ballmap
i.MX253	MCIMX253DVM4!	1.1	-20 to +70	17 x 17 mm, 0.8 mm pitch, MAPBGA-400	Table 101
i.MX257	MCIMX257DVM4!	1.1	-20 to +70	17 x 17 mm, 0.8 mm pitch, MAPBGA-400	Table 101
i.MX253	MCIMX253CVM4!	1.1	-40 to +85	17 x 17 mm, 0.8 mm pitch, MAPBGA-400	Table 101
i.MX257	MCIMX257CVM4!	1.1	-40 to +85	17 x 17 mm, 0.8 mm pitch, MAPBGA-400	Table 101
i.MX258	MCIMX258CVM4!	1.1	-40 to +85	17 x 17 mm, 0.8 mm pitch, MAPBGA-400	Table 101
i.MX253	MCIMX253DJM4	1.1	-20 to +70	17 x 17 mm, 0.8 mm pitch, MAPBGA-400	Table 101
i.MX257	MCIMX257DJM4	1.1	-20 to +70	17 x 17 mm, 0.8 mm pitch, MAPBGA-400	Table 101
i.MX253	MCIMX253CJM4	1.1	-40 to +85	17 x 17 mm, 0.8 mm pitch, MAPBGA-400	Table 101
i.MX257	MCIMX257CJM4	1.1	-40 to +85	17 x 17 mm, 0.8 mm pitch, MAPBGA-400	Table 101
i.MX258	MCIMX258CJM4	1.1	-40 to +85	17 x 17 mm, 0.8 mm pitch, MAPBGA-400	Table 101
i.MX253	MCIMX253DJM4A	1.2	-20 to +70	17 x 17 mm, 0.8 mm pitch, MAPBGA-400	Table 101
i.MX257	MCIMX257DJM4A	1.2	-20 to +70	17 x 17 mm, 0.8 mm pitch, MAPBGA-400	Table 101
i.MX257	MCIMX257DJM4AR2	1.2	-20 to +70	17 x 17 mm, 0.8 mm pitch, MAPBGA-400	Table 101
i.MX253	MCIMX253CJM4A	1.2	-40 to +85	17 x 17 mm, 0.8 mm pitch, MAPBGA-400	Table 101
i.MX257	MCIMX257CJM4A	1.2	-40 to +85	17 x 17 mm, 0.8 mm pitch, MAPBGA-400	Table 101
i.MX258	MCIMX258CJM4A	1.2	-40 to +85	17 x 17 mm, 0.8 mm pitch, MAPBGA-400	Table 101
i.MX257	MCIMX257CJN4A	1.2	-40 to +85	12 x 12mm, 0.5mm pitch, MAPBGA-347	Table 105

¹ Because of an order from the United States International Trade Commission, BGA-packaged product lines and part numbers indicated here currently are not available from Freescale for import or sale in the United States prior to September 2010: Indicated by the Icon (!)

Table 2 shows the functional differences between the different parts in the i.MX25 family.

Table 2. i.MX25 Parts Functional Differences

Features	MCIMX253	MCIMX257	MCIMX258
Core	ARM926EJ-S™	ARM926EJ-S™	ARM926EJ-S™
CPU Speed	400 MHz	400 MHz	400 MHz
L1 I/D Cache	16K I/D	16K I/D	16K I/D
On-chip SRAM	128 KB	128 KB	128 KB
PATA/CE-ATA	Yes	Yes	Yes
LCD Controller	Yes	Yes	Yes
Touchscreen	—	Yes	Yes
CSI	—	Yes	Yes
FlexCAN (2)	—	Yes	Yes
ESAI	—	Yes	Yes
SIM (2)	—	Yes	Yes
Security	—	—	Yes
10/100 Ethernet	Yes	Yes	Yes
HS USB 2.0 OTG + PHY	Yes	Yes	Yes
HS USB 2.0 Host + PHY	Yes	Yes	Yes
12-bit ADC	Yes	Yes	Yes
SD/SDIO/MMC (2)	Yes	Yes	Yes
External Memory Controller	Yes	Yes	Yes
I ² C (3)	Yes	Yes	Yes
SSI/I2S (2)	Yes	Yes	Yes
CSPI (2)	Yes	Yes	Yes
UART (5)	Yes	Yes	Yes

1.2 Block Diagram

Figure 1 shows the simplified interface block diagram.

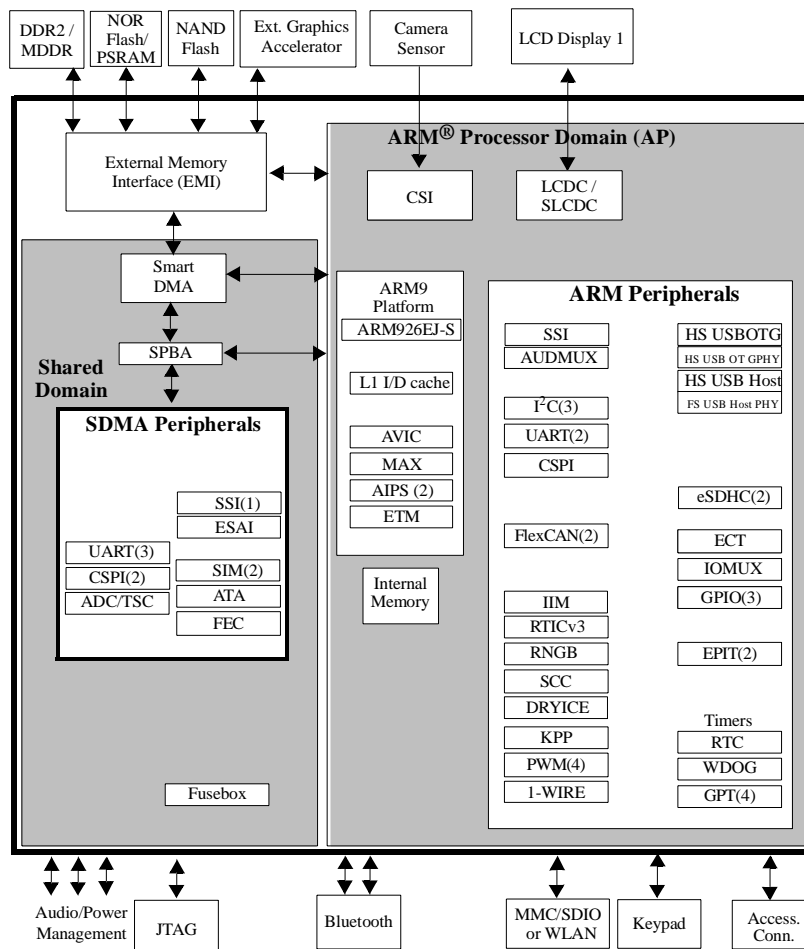

Figure 1. i.MX25 Simplified Interface Block Diagram

2 Features

Table 3 describes the digital and analog modules of the device.

Table 3. i.MX25 Digital and Analog Modules

Block Mnemonic	Block Name	Subsystem	Brief Description
1-WIRE	1-Wire Interface	Connectivity peripherals	1-Wire support provided for interfacing with an on-board EEPROM, and smart battery interfaces, for example: Dallas DS2502.
ARM9 or ARM926	ARM926 platform and memory	ARM®	The ARM926 Platform consists of the ARM926EJ-S™ core, the ETM real-time debug modules, a 5x5 Multi-Layer AHB crossbar switch, and a “primary AHB” complex. It contains the 16-Kbyte L1 instruction cache, 16-Kbyte L1 data cache, 32-Kbyte ROM and 128-Kbyte RAM.
ATA	ATA module	Connectivity peripherals	The ATA module is an AT attachment host interface. Its main use is to interface with IDE hard disc drives and ATAPI optical disc drives. It interfaces with the ATA device over a number of ATA signals.
AUDMUX	Digital audio mux	Multimedia peripherals	The AUDMUX is a programmable interconnect for voice, audio, and synchronous data routing between host serial interfaces (SSIs) and peripheral serial interfaces (audio codecs). The AUDMUX has two sets of interfaces: internal ports to on-chip peripherals, and external ports to off-chip audio devices. Data is routed by configuring the appropriate internal and external ports.
CCM	Clock control module	Clocks	This block generates all clocks for the iMX25 system. The CCM also manages the ARM926 Platform's low-power modes (wait, stop, and doze) by disabling peripheral clocks appropriately for power conservation.
CSPI(3)	Configurable serial peripheral interface	Connectivity peripherals	This module is a serial interface equipped with data FIFOs. Each master/slave-configurable SPI module is capable of interfacing to both serial port interface master and slave devices. The CSPI ready (SPI_RDY) and Slave Select (SS) control signals enable fast data communication with fewer software interrupts.
DRYICE	DryIce module	Security	DryIce provides volatile key storage for Point-of-Sale (POS) terminals, and a trusted time source for Digital Rights Management (DRM) schemes. Several tamper-detect circuits are also provided to support key erasure and time invalidation in the event of tampering. Alarms and/or interrupts can also assert if tampering is detected. DryIce also includes a Real Time clock (RTC) that can be used in secure and non-secure applications.
EMI	External memory interface	Connectivity peripherals	The External Memory Interface (EMI) module provides access to external memory for the ARM and other masters. It is composed of four main submodules: <ul style="list-style-type: none"> • M3IF provides arbitration between multiple masters requesting access to the external memory. • Enhanced SDRAM/LPDDR memory controller (ESDCTL) interfaces to DDR2 and SDR interfaces. • NAND Flash controller (NFC) provides an interface to NAND Flash memories. • Wireless External Interface Memory controller (WEIM) interfaces to NOR Flash and PSRAM.

Table 3. i.MX25 Digital and Analog Modules (continued)

Block Mnemonic	Block Name	Subsystem	Brief Description
EPIT(2)	Enhanced periodic interrupt timer	Timer peripherals	Each Enhanced Periodic Interrupt Timer (EPIT) is a 32-bit set-and-forget timer that starts counting after the EPIT is enabled by software. It is capable of providing precise interrupts at regular intervals with minimal processor intervention. It has a 12-bit prescaler to adjust the input clock frequency to the required time setting for the interrupts, and the counter value can be programmed on the fly.
ESAI	Enhanced serial audio interface	Connectivity peripherals	ESAI provides a full-duplex serial port for serial communication with a variety of serial devices, including industry-standard codecs, SPDIF transceivers, and other DSPs. The ESAI consists of independent transmitter and receiver sections, each section with its own clock generator.
eSDHC(2)	Enhanced multimedia card/secure digital host controller	Connectivity peripherals	The features of the eSDHC module, when serving as host, include the following: <ul style="list-style-type: none"> • Conforms to the SD host controller standard specification version 2.0 • Compatible with the JEDEC MMC system specification version 4.2 • Compatible with the SD memory card specification version 2.0 • Compatible with the SDIO specification version 1.2 • Designed to work with SD memory, miniSD memory, SDIO, miniSDIO, SD combo, MMC and MMC RS cards • Configurable to work in one of the following modes: <ul style="list-style-type: none"> —SD/SDIO 1-bit, 4-bit —MMC 1-bit, 4-bit, 8-bit • Full-/high-speed mode • Host clock frequency variable between 32 kHz and 52 MHz • Up to 200-Mbps data transfer for SD/SDIO cards using four parallel data lines • Up to 416-Mbps data transfer for MMC cards using eight parallel data lines
FEC	Fast ethernet controller	Connectivity peripherals	The Ethernet Media Access Controller (MAC) is designed to support both 10- and 100-Mbps Ethernet networks compliant with IEEE 802.3 [®] standard. An external transceiver interface and transceiver function are required to complete the interface to the media
FlexCAN(2)	Controller area network module	Connectivity peripherals	The Controller Area Network (CAN) protocol is primarily designed to be used as a vehicle serial data bus running at 1 MBps.
GPIO(4)	General purpose I/O modules	System control peripherals	Used for general purpose input/output to external ICs. Each GPIO module supports 32 bits of I/O.
GPT(4)	General purpose timers	Timer peripherals	Each GPT is a 32-bit free-running or set-and-forget mode timer with programmable prescaler and compare and capture register. A timer counter value can be captured using an external event and can be configured to trigger a capture event on either the leading or trailing edges of an input pulse. When the timer is configured to operate in set-and-forget mode, it is capable of providing precise interrupts at regular intervals with minimal processor intervention. The counter has output compare logic to provide the status and interrupt at comparison. This timer can be configured to run either on an external clock or on an internal clock.

Table 3. i.MX25 Digital and Analog Modules (continued)

Block Mnemonic	Block Name	Subsystem	Brief Description
I ² C(3)	I ² C module	Connectivity peripherals	Inter-IC Communication (I ² C) is an industry-standard, bidirectional serial bus that provides a simple, efficient method of data exchange, minimizing the interconnection between devices. I ² C is suitable for applications requiring occasional communications over a short distance between many devices. The interface operates up to 100 kbps with maximum bus loading and timing. The I ² C system is a true multiple-master bus, including arbitration and collision detection that prevents data corruption if multiple devices attempt to control the bus simultaneously. This feature supports complex applications with multiprocessor control and can be used for rapid testing and alignment of end products through external connections to an assembly-line computer.
IIM	IC Identification Module	Security	The IIM provides the primary user-visible mechanism for interfacing with on-chip fuse elements. Among the uses for the fuses are unique chip identifiers, mask revision numbers, cryptographic keys, and various control signals requiring a fixed value.
IOMUX	I/O multiplexer	Pins	Each I/O multiplexer provides a flexible, scalable multiplexing solution: <ul style="list-style-type: none"> • Up to eight output sources multiplexed per pin • Up to four destinations for each input pin • Unselected input paths are held at constant level for reduced power consumption
KPP	Keypad port	Connectivity peripherals	KPP can be used for either keypad matrix scanning or general purpose I/O.
LCDC	LCD Controller	Multimedia peripherals	LCDC provides display data for external gray-scale or color LCD panels. LCDC is capable of supporting black-and-white, gray-scale, passive-matrix color (passive color or CSTN), and active-matrix color (active color or TFT) LCD panels.
MAX	ARM platform multilayer AHB crossbar switch	ARM platform	MAX concurrently supports up to five simultaneous connections between master ports and slave ports. MAX allows for concurrent transactions to occur from any master port to any slave port.
PWM(4)	Pulse width modulation	Connectivity peripherals	The Pulse-Width Modulator (PWM) has a 16-bit counter and is optimized to generate sound from stored sample audio images. It can also generate tones. The PWM uses 16-bit resolution and a 4x16 data FIFO to generate sound.
SDMA	Smart DMA engine	System control	The SDMA provides DMA capabilities inside the processor. It is a shared module that implements 32 DMA channels.
SIM(2)	Subscriber identity module interface	Connectivity peripherals	The SIMv2 is an asynchronous interface with additional features for allowing communication with smart cards conforming to the ISO/IEC 7816 specification. The SIM is designed to facilitate communication to SIM cards or pre-paid phone cards.
SJC	Secure JTAG interface	System control peripherals	The System JTAG Controller (SJC) provides debug and test control with maximum security.
SLCD	Smart LCD controller	Multimedia peripherals	The SLCDC module transfers data from the display memory buffer to the external display device.
SPBA	Shared peripheral bus arbiter	System control	The SPBA controls access to the shared peripherals. It supports shared peripheral ownership and access rights to an owned peripheral.

Table 3. i.MX25 Digital and Analog Modules (continued)

Block Mnemonic	Block Name	Subsystem	Brief Description
SSI(2)	I2S/SSI/AC97 interface	Connectivity peripherals	The SSI is a full-duplex serial port that allows the processor to communicate with a variety of serial protocols, including the Freescale Semiconductor SPI standard and the inter-IC sound bus standard (I2S). The SSIs interface to the AUDMUX for flexible audio routing.
TSC (and ADC)	Touchscreen controller (and A/D converter)	Multimedia peripherals	The touchscreen controller and associated Analog-to-Digital Converter (ADC) together provide a resistive touchscreen solution. The module implements simultaneous touchscreen control and auxiliary ADC operation for temperature, voltage, and other measurement functions.
UART(5)	UART interface	Connectivity peripherals	Each of the UART modules supports the following serial data transmit/receive protocols and configurations: <ul style="list-style-type: none"> • 7- or 8-bit data words, one or two stop bits, programmable parity (even, odd, or none) • Programmable baud rates up to 4 MHz. This is a higher maximum baud rate than the 1.875 MHz specified by the TIA/EIA-232-F standard and previous Freescale UART modules. 32-byte FIFO on Tx and 32 half-word FIFO on Rx supporting auto-baud • IrDA-1.0 support (up to SIR speed of 115200 bps) • Option to operate as 8-pins full UART, DCE, or DTE
USBOTG USBHOST	High-speed USB on-the-go	Connectivity peripherals	The USB module provides high-performance USB On-The-Go (OTG) and host functionality (up to 480 Mbps), compliant with the USB 2.0 specification, the OTG supplement, and the ULPI 1.0 Low Pin Count specification. The module has DMA capabilities for handling data transfer between internal buffers and system memory. An OTG HS PHY and HOST FS PHY are also integrated.

2.1 Special Signal Considerations

Special signal considerations are listed in [Table 4](#). The package contact assignment is found in [Section 4](#), “[Package Information and Contact Assignment](#).” Signal descriptions are provided in the reference manual.

Table 4. Signal Considerations

Signal	Description
BAT_VDD	Drylce backup power supply input.
CLK0	Clock-out pin; renders the internal clock visible to users for debugging. The clock source is controllable through CRM registers. This pin can also be configured (through muxing) to work as a normal GPIO.
CLK_SEL	Used to select the ARM clock source from MPLL out or from external EXT_ARMCLK. In normal operation, CLK_SEL should be connected to GND.
EXT_ARMCLK	Primarily for Freescale factory use. There is no internal on-chip pull-up/down on this pin, so it must be externally connected to GND or VDD. Aside from factory use, this pin can also be configured (through muxing) to work as a normal GPIO.
MESH_C, MESH_D	Wire-mesh tamper detect pins that can be routed at the PCB board to detect attempted tampering of a protected wire. When security measures are implemented, MESH_C should be pulled-up or connected to NVCC_DRYICE and triggers a tamper event when floating or when connected to MESH_D. MESH_D should be pulled-down or connected to GND and triggers an event when floating or connected to MESH_C. These pins can be left unconnected if the Drylce security features are not being used.

Table 4. Signal Considerations (continued)

Signal	Description
NVCC_DRYICE	Drylce power supply output. The supply source is QVDD, when the i.MX25 is in run mode and the backup supply is BATT_VDD when it is in reduced power mode. This pin can be used to power external components (external tamper detect, wire-mesh tamper detect).
OSC_BYP	The 32 kHz oscillator bypass-control pin. If this signal is pulled down, then OSC32K_EXTAL and OSC32K_XTAL analog pins should be tied to the external 32.768 kHz crystal circuit. If on the other hand the signal is pulled up, then the external 32 kHz oscillator output clock must be connected to OSC32K_EXTAL analog pin, and OSC32K_XTAL can be no connect (NC).
OSC32K_EXTAL OSC32K_XTAL	These analog pins are connected to an external 32 kHz CLK circuit depending on the state of OSC_BYP pin (see the description of OSC_BYP under the preceding bullet). The 32 kHz reference CLK is required for normal operation.
POWER_FAIL	An interrupt from PMIC, which should be connected to a low-battery detection circuit. This signal is internally connected to an on-chip 100 k Ω pull-down device. If there is no low-battery detection, then users can tie this pin to GND through a pull-down resistor, or leave the signal as NC. This pin can also be configured to work as a normal GPIO.
REF	External ADC reference voltage. REF may be tied to GND if the user plans to only use the internally generated 2.5 V reference supply.
SJC_MOD	Must be externally connected to GND for normal operation. Termination to GND through an external pull-down resistor (such as 1 k Ω) is allowed, but the value should be much smaller than the on-chip 100-k Ω pull-up.
TAMPER_A, TAMPER_B	Drylce external tamper detect pins, active high. If TAMPER_A or TAMPER_B is connected to NVCC_DRYICE, then external tampering is detected. These pins can be left unconnected if the Drylce security features are not being used.
TEST_MODE	For Freescale factory use only. This signal is internally connected to an on-chip pull-down device. Users must either float this signal or tie it to GND.
UPLL_BYPCLK	Primarily for Freescale factory use. There is no internal on-chip pull-up/down on this pin, so it must be externally connected to GND or VDD. Aside from factory use, this pin can also be configured (through muxing) to work as a normal GPIO.
USBPHY1_RREF	Determines the reference current for the USB PHY1 bandgap reference. An external 10 k Ω 1% resistor to GND is required.
USBPHY2_DM USBPHY2_DP	The output impedance of these signals is expected at 10 Ω . It is recommended to also have on-board 33 Ω series resistors (close to the pins).

3 Electrical Characteristics

This section provides the device-level and module-level electrical characteristics for the i.MX25.

3.1 i.MX25 Chip-Level Conditions

This section provides the chip-level electrical characteristics for the IC.

3.1.1 DC Absolute Maximum Ratings

Table 5 provides the DC absolute maximum operating conditions.

CAUTION

- Stresses beyond those listed under Table 5 may cause permanent damage to the device.
- Exposure to absolute-maximum-rated conditions for extended periods may affect device reliability.
- Table 5 gives stress ratings only—functional operation of the device is not implied beyond the conditions indicated in Table 6.

Table 5. DC Absolute Maximum Ratings

Parameter	Symbol	Min.	Max.	Units
Supply voltage	QV_{DD}	-0.5	1.52	V
Supply voltage (level shift i/o)	$V_{DDIOmax}$	-0.5	3.6	V
ESD damage immunity:	V_{esd}			V
Human body model (HBM)		—	2500	
Charge device model (CDM)		—	400	
Machine model (MM)		—	200	
Input voltage range	$V_{I_{max}}$	-0.5	$NV_{DD} + 0.3$	V
Storage temperature range	$T_{storage}$	-40	105	°C

3.1.2 DC Operating Conditions

Table 6 provides the DC recommended operating conditions.

Table 6. DC Operating Conditions

Parameter	Symbol	Min.	Typ.	Max.	Units
Core supply voltage (at 266 MHz)	QV_{DD}	1.15	1.34	1.52	V
Core supply voltage (at 400 MHz)	QV_{DD}	1.38	1.45	1.52	V
Coin battery ¹ BAT_VDD	V_{DD_BAT}	1.15	—	1.55	V
I/O supply voltage, GPIO NFC,CSI,SDIO	NV_{DD_GPIO1}	1.75	—	3.6	V

Table 6. DC Operating Conditions (continued)

Parameter	Symbol	Min.	Typ.	Max.	Units
I/O supply voltage, GPIO CRM,LCDC,JTAG,MISC	NV_{DD_GPIO2}	3.0	3.3	3.6	—
I/O supply voltage DDR (Mobile DDR mode) EMI1, EMI2	NV_{DD_MDDR}	1.75	—	1.95	V
I/O supply voltage DDR (DDR2 mode) EMI1,EMI2	NV_{DD_DDR2}	1.75	—	1.9	V
I/O supply voltage DDR (SDRAM mode) EMI1,EMI2	NV_{DD_SDRAM}	1.75	—	3.6	V
Supply of USBPHY1 (HS) USBPHY1_VDDA_BIAS, USBPHY1_UPLL_VDD,USBPHY1_VDDA	$V_{DD_usbphy1}$	3.17	3.3	3.43	V
Supply of USBPHY2 (FS) USBPHY2_VDD	$V_{DD_usbphy2}$	3.0	3.3	3.6	V
Supply of OSC24M OSC24M_VDD	V_{DD_OSC24M}	3.0	3.3	3.6	V
Supply of PLL MPLL_VDD,UPLL_VDD	V_{DD_PLL}	1.4	—	1.65	V
Supply of touchscreen ADC NVCC_ADC	V_{DD_tsc}	3.0	3.3	3.6	V
External reference of touchscreen ADC Ref	Vref	2.5	V_{DD_tsc}	V_{DD_tsc}	V
Fusebox program supply voltage FUSE_VDD ²	$FUSEV_{DD}$ (program mode)	$3.3 \pm 5\%$	—	3.6	V
Supply output ³ NVCC_DRYICE	$V_{DD_}$	1.0	—	1.55	V
Operating ambient temperature	T_A	−40	—	85	°C

¹ V_{DD_BAT} must always be powered by battery in security application. In non-security case, V_{DD_BAT} can be connected to QV_{DD} .

² The fusebox read supply is connected to supply of the full speed USBPHY2_VDD. FUSE_VDD is only used for programming. It is recommended that FUSE_VDD be connected to ground when not being used for programming. See [Table 7](#) for current parameters.

³ NVCC_DRYICE is supply output. A 0.1- μ F external capacitor should be connected to it.

3.1.3 Fusebox Supply Current Parameters

Table 7 lists the fusebox supply current parameters.

Table 7. Fusebox Supply Current Parameters

Parameter	Symbol	Min.	Typ.	Max.	Units
eFuse program current ¹ Current to program one eFuse bit The associated VDD_FUSE supply = 3.6 V	I_{program}	26	35	62	mA
eFuse read current ² Current to read an 8-bit eFuse word	I_{read}	—	12.5	15	mA

¹ The current I_{program} is during program time (t_{program}).

² The current I_{read} is present for approximately 50 ns of the read access to the 8-bit word.

3.1.4 Interface Frequency Limits

Table 8 provides information for interface frequency limits.

Table 8. Interface Frequency Limits

Parameter	Min.	Typ.	Max.	Units
JTAG: TCK Frequency of Operation	DC	5	10	MHz
OSC24M_XTAL Oscillator	—	24	—	MHz
OSC32K_XTAL Oscillator	—	32.768	—	KHz

3.1.5 USB_PHY Current Consumption

Table 9 provides information for USB_PHY current consumption.

Table 9. USB PHY Current Consumption¹

Parameter	Conditions		Typ. (@Typ. Temp)	Max. (@Max. Temp)	Unit
Analog supply USBPHY1_VDDA_BIAS, USBPHY1_UPLL_VDD, USBPHY1_VDDA (3.3 V)	Full speed	Rx	11.4	—	mA
		Tx	22.6	—	
	High speed	Rx	21.5	—	
		Tx	33.8	—	
	Suspend	—	0.6	—	μA
Analog supply USBPHY2_VDD (3.3 V)	Full Speed	Rx	120	—	μA
		Tx	25	—	mA
	Low Speed	Rx	252	—	μA
		Tx	5.5	—	mA
All supplies	Suspend		50	100	μA

¹ Values must be verified

3.1.6 Power Modes

Table 10 describes the core, clock, and module settings for the different power modes of the processor.

Table 10. i.MX25 Power Mode Settings

Core/Clock/Module	Power Mode				
	Doze	Wait	Stop/Sleep ¹	Run (266 MHz)	Run (400 MHz)
ARM core	Platform clock is off	In wait-for-interrupt mode	—	Active @ 266 MHz	Active @ 400 MHz
Well bias	On	Off	On	Off	Off
MCU PLL	On	On	Off	On	On
USB PLL	Off	Off	Off	On	On
OSC24M	On	On	Off	On	On
OSC32K	On	On	On	On	On
Other modules	Off	Off	Off	On	On

¹ Sleep mode differs from stop mode in that the core voltage is reduced to 1 V.

Table 11 shows typical current consumption for the various power supplies under the various power modes.

Table 11. i.MX25 Power Mode Current Consumption

Power Group	Power Supplies	Voltage Setting	Current Consumption for Power Modes ¹			
			Doze	Wait	Stop	Sleep
NVCC_EMI	NVCC_EMI1 NVCC_EMI2	3.0 V	5 μ A	3.15 μ A	3.51 μ A	3.61 μ A
NVCC_CRM	NVCC_CRM	3.0 V	1.15 μ A	4.31 μ A	0.267 μ A	0.32 μ A
NVCC_OTHER	NVCC_SDIO NVCC_CSI NVCC_NFC NVCC_JTAG NVCC_LCDC NVCC_MISC	3.0 V	31.2 μ A	29.5 μ A	31.7 μ A	32.1 μ A
NVCC_ADC	NVCC_ADC	3.0 V	163 μ A	3.25 μ A	1.14 μ A	0.871 μ A
OSC24M	OSC24M_VDD	3.0 V	906 μ A	903 μ A	10.2 μ A	10.5 μ A
PLL_VDD	MPLL_VDD UPLL_VDD	1.4 V	6.83 mA	6.83 mA	38.9 μ A	39.1 μ A
QVDD	QVDD	1.15 V	8.79 mA	11.28 mA	842 μ A	665 μ A
USBPHY1_VDDA	USBPHY1_VDDA	3.17 V	240 μ A	240 μ A	241 μ A	242 μ A
USBPHY1_VDDA_VBIAS	USBPHY1_VDDA_VBIAS	3.17 V	0.6 μ A	1.46 μ A	0.328 μ A	0.231 μ A
USBPHY1_UPLL_VDD	USBPHY1_UPLL_VDD	3.17 V	201 μ A	201 μ A	191 μ A	191 μ A
USBPHY2	USBPHY2_VDD	3.0 V	158 μ A	0158 μ A	164 μ A	164 μ A

¹ Values are typical, under typical use conditions.

In the reduced power mode, shown in Table 12, the i.MX25 is powered down, while the RTC clock and the secure keys (in secure-use case), remain operational. BAT_VDD is tied to a battery while all other supplies are turned off.

NOTE

In this low-power mode, i.MX25 cannot be woken up with an interrupt; it must be powered back up before it can detect any events.

Table 12. iMX25 Reduced Power Mode Current Consumption

Power Group	Power Supply	Voltage Setting	Typical Current Consumption
BAT_VDD	BAT_VDD	1.15 V	9.95 μ A
		1.55 V	12.6 μ A

3.2 Supply Power-Up/Power-Down Requirements and Restrictions

Any i.MX25 board design must comply with the power-up and power-down sequence guidelines given in this section to ensure reliable operation of the device. Recommended power-up and power-down sequences are given in the following subsections.

CAUTION

Deviations from the guidelines in this section may result in the following situations:

- Excessive current during power-up phase
- Prevention of the device from booting
- Irreversible damage to the i.MX25 (worst-case scenario)

NOTE

For security applications, the coin battery must be connected during both power-up and power-down sequences to ensure that security keys are not unintentionally erased.

3.2.1 Power-Up Sequence

The following power-up sequence is recommended:

1. Assert power on reset (POR).
2. Turn on digital logic domain and I/O power supplies VDD_n and NVCC_x.
3. Turn on all other analog power supplies, including USBPHY1_VDDA_BIAS, USBPHY1_UPLL_VDD, USBPHY1_VDDA, USBPHY2_VDD, OSC24M_VDD, MPPLL_VDD, UPLL_VDD, NVCC_ADC, and FUSEVDD (FUSEVDD is tied to GND if fuses are not being programmed). The minimum time between turning on each power supply is the time it takes for the previous supply to be stable.
4. Negate the POR signal.

NOTE

- The user is advised to connect FUSEVDD to GND except when fuses are being programmed, in order to prevent unintentional blowing of fuses.
- Other power-up sequences may be possible; however, the above sequence has been verified and is recommended.
- There is a 1-ms minimum time between supplies coming up, and a 1-ms minimum time between POR_B assert and deassert.

Figure 2 shows the power-up sequence diagram. After POR_B is asserted, Core VDD and NVDDx can be powered up. After Core VDD and NVDDx are stable, the analog supplies can be powered up.

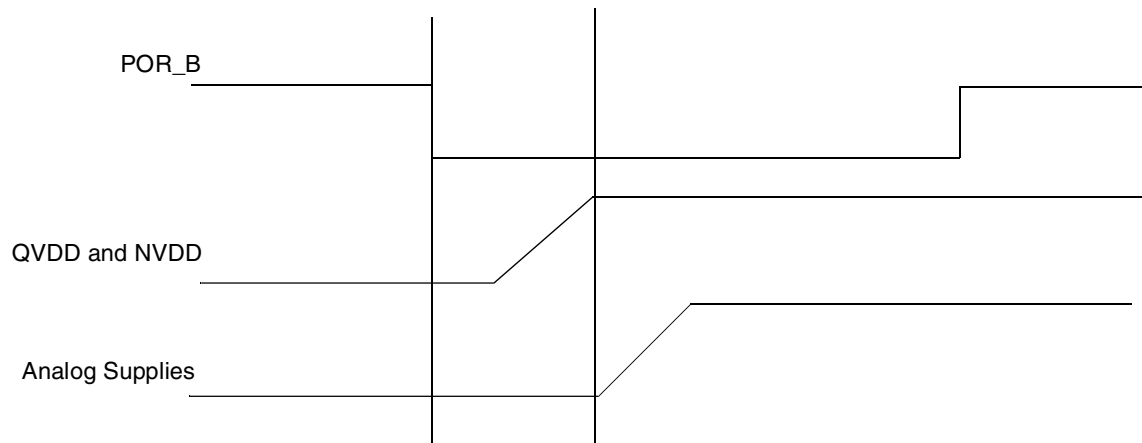

Figure 2. Power-Up Sequence Diagram

3.2.2 Power-Down Sequence

There are no special requirements for the power-down sequence. All power supplies can be shut down at the same time.

3.2.3 SRTC DryIce Power-Up/Down Sequence

In order to guarantee DryIce power-loss protection, which includes that SRTC time is kept during power-down, users must follow the specific power-Up/Down sequence.

For users who want to utilize the DryIce power-loss protection feature, the following power-up sequence is recommended:

1. Assert Power on reset (POR).
2. Turn on NVCC_CRM.
3. At any time from step 2 and to step 4, turn on other digital I/O power suppliers NVCCx.
4. Turn on digital logic domain QVDD no less than 1 ms and no greater than 32 ms after NVCC_CRM reaches 90 % of 3.3 V. Step 2 and step 4 order are critical for proper power-loss protection.

NOTE

This is to guarantee that POR is stable already at NVCC_CRM/QVDD power domain interface before QVDD is on, and POR instantly propagates to QVDD domain after QVDD is on.

5. Turn on all other analog power supplies including USBPHY1_VDDA_BIAS, USBPHY1_UPLL_VDD, USBPHY1_VDDA, USBPHY2_VDD, NVCC_ADC, OSC24M_VDD, MPPLL_VDD, UPLL_VDD and FUSEVDD no less than 1ms and no greater than 32 ms after QVDD reaches 90% of 1.2V. FUSEVDD is tied to GND if fuses are not being programmed.

NOTE

This is to guarantee that analog peripherals can get properly initialized (reset) values from QVDD domain and NVCCx domain.

6. Negate the POR signal at least 90 μ s after all previous steps.

NOTE

This is to guarantee that both POR logic and clocks are stable inside the MX25 chip, before POR is removed.

In addition, the following power-down sequence is recommended:

1. Turn off power for analog parts, including USBPHY1_VDDA_BIAS, USBPHY1_UPLL_VDD, USBPHY1_VDDA, USBPHY2_VDD, NVCC_ADC, and FUSEVDD (FUSEVDD is tied to GND if fuses are not being programmed).
2. Turn off QVDD.
3. Turn off NVCCx, PLL, OSC, and other powers.

NOTE

The power-down steps can be executed simultaneously, or very shortly one after another.

3.3 Power Characteristics

Table 13 shows values representing maximum current numbers for the i.MX25 under worst case voltage and temperature conditions. These values are derived from the i.MX25 with core clock speed up to 400 MHz. Additionally, no power saving techniques such as clock gating were implemented when measuring these values. Common supplies are bundled according to the i.MX25 power-up sequence requirements. Peak numbers are provided for system designers so that the i.MX25 power supply requirements are satisfied during startup and transient conditions. Freescale recommends that system current measurements are taken with customer-specific use-cases to reflect the normal operating conditions in the end system.

Table 13. Power Consumption

Power Supply	Voltage (V)	Max Current (mA)
QVDD	1.52	360
NVCC_EMI1, NVCC_EMI2	1.9	30
NVCC_CRM, NVCC_SDIO, NVCC_CSI, NVCC_NFC, NVCC_JTAG, NVCC_LCDC, NVCC_MISC	3.6	110
MPLL_VDD, UPLL_VDD	1.65	20
USBPHY1_VDDA_BIAS, USBPHY1_UPLL_VDD, USBPHY1_VDDA, USBPHY2_VDD, OSC24M_VDD, NVCC_ADC	3.3	40
FUSE_VDD ¹	3.6	62
BATT_VDD	1.55	0.030

¹ The FUSE_VDD rail is connected to ground. It only needs a voltage if the system fuse burning is needed.

The method for obtaining the maximum current is as follows:

1. Measure the worst case power consumption on individual rails using directed test on i.MX25.
2. Correlate the worst case power consumption power measurements with the worst case power consumption simulations.
3. Combine common voltage rails based on the power supply sequencing requirements (add the worst case power consumption on each rail within some test cases from several test cases run, to maximize different rails in the power group).
4. Guard the worst case numbers for temperature and process variation.
5. **The sum of individual rails is greater than the real world power consumption, since a real system does not typically maximize the power consumption on all peripherals simultaneously.**
6. BATT_VDD current is measured when the system is in reduced power mode maintaining the RTC. When the system is in run mode, QVDD is used to supply the DryIce, so this current becomes negligible. Refer to [Table 10](#), for more details on the power modes.

NOTE

The values mentioned above should not be taken as a typical max run data for specific use cases. These values are Absolute MAX data. Freescale recommends that the system current measurements are taken with customer-specific use-cases to reflect normal operating conditions in the end system

3.4 Thermal Characteristics

The thermal resistance characteristics for the device are given in [Table 14](#). These values are measured under the following conditions:

- Two-layer substrate
- Substrate solder mask thickness: 0.025 mm
- Substrate metal thicknesses: 0.016 mm
- Substrate core thickness: 0.200 mm
- Core through I.D: 0.118 mm, Core through plating 0.016 mm.
- Flag: Trace style with ground balls under the die connected to the flag
- Die Attach: 0.033 mm non-conductive die attach, $k = 0.3 \text{ W/m K}$
- Mold compound: Generic mold compound; $k = 0.9 \text{ W/m K}$

Table 14. Thermal Resistance Data

Rating	Condition	Symbol	Value	Unit
Junction to ambient ¹ natural convection	Single layer board (1s)	R_{eJA}	55	°C/W
Junction to ambient ¹ natural convection	Four layer board (2s2p)	R_{eJA}	33	°C/W

Table 14. Thermal Resistance Data (continued)

Rating	Condition	Symbol	Value	Unit
Junction to ambient ¹ (@ 200 ft/min)	Single layer board (1s)	R _{eJMA}	46	°C/W
Junction to ambient ¹ (@ 200 ft/min)	Four layer board (2s2p)	R _{eJMA}	29	°C/W
Junction to boards ²	—	R _{eJB}	22	°C/W
Junction to case (top) ³	—	R _{eJCtop}	13	°C/W
Junction to package top ⁴	Natural convection	Ψ _{JT}	2	°C/W

¹ Junction-to-ambient thermal resistance determined per JEDC JESD51-3 and JESD51-6. Thermal test board meets JEDEC specification for this package.

² Junction-to-board thermal resistance determined per JEDC JESD51-8. Thermal test board meets JEDEC specification for this package.

³ Junction-to-case at the top of the package determined using MIL-STD 883 Method 1012.1. The cold plate temperature is used for the case temperature. Reported value includes the thermal resistance of the interface layer.

⁴ Thermal characterization parameter indicating the temperature difference between the package top and the junction temperature per JEDEC JESD51-2. When Greek letters are not available, this thermal characterization parameter is written as Psi-JT.

3.5 I/O DC Parameters

This section includes the DC parameters of the following I/O types:

- DDR I/O: Mobile DDR (mDDR), double data rate (DDR2), or synchronous dynamic random access memory (SDRAM)
- General purpose I/O (GPIO)

NOTE

The term ‘OVDD’ in this section refers to the associated supply rail of an input or output. The association is shown in the “Signal Multiplexing” chapter of the reference manual.

3.5.1 DDR I/O DC Parameters

The DDR pad type is configured by the IOMUXC_SW_PAD_CTL_GRP_DDRTYPE register (see the External Signals and Pin Multiplexing chapter of the *i.MX25 Reference Manual* for details).

3.5.1.1 DDR_TYPE = 00 Standard Setting DDR I/O DC Parameters

Table 15 shows the I/O parameters for mobile DDR. These settings are suitable for mDDR and DDR2 1.8V ($\pm 5\%$) applications.

Table 15. Mobile DDR I/O DC Electrical Characteristics

DC Electrical Characteristics	Symbol	Test Conditions	Min.	Typ.	Max.	Units	Notes
High-level output voltage	Voh	$I_{OH} = -1\text{mA}$ $I_{OH} = \text{Specified Drive}$	$OVDD - 0.08$ $0.8 \times OVDD$	—	—	V	1
Low-level output voltage	Vol	$I_{OL} = 1\text{mA}$ $I_{OL} = \text{Specified Drive}$	—	—	0.08 $0.2 \times OVDD$	V	
High-level output current	I Ioh	$V_{oh} = 0.8 \times OVDDV$ Standard Drive High Drive Max. Drive	-3.6 -7.2 -10.8	—	—	mA	—
Low-level output current	I Iol	$V_{ol} = 0.2 \times OVDDV$ Standard Drive High Drive Max. Drive	3.6 7.2 10.8	—	—	mA	—
High-level DC CMOS input voltage	VIH	—	$0.7 \times OVDD$	OVDD	$OVDD + 0.3$	V	—
Low-level DC CMOS input voltage	VIL	—	-0.3	0	$0.3 \times OVDD$	V	
Differential receiver VTH+	VTH+	—		—	100	mV	
Differential receiver VTH-	VTH-	—	-100	—	—	mV	
Input current (no pull-up/down)	IIN	$V_I = 0$ $V_I = OVDD$	—	—	110 60	nA	2, 3
High-impedance I/O supply current	Icc-ovdd	$V_I = OVDD$ or 0	—	—	990	nA	2, 3
High-impedance core supply current	Icc-vddi	$V_I = VDD$ or 0	—	—	1220	nA	

Note:

- Simulation circuit for parameters Voh and Vol for I/O cells is below
- Minimum condition: BCS model, 1.95 V, and -40°C . Typical condition: typical model, 1.8 V, and 25°C . Maximum condition: wcs model, 1.65 V, and 105°C .
- Typical condition: typical model, 1.8 V, and 25°C . Maximum condition: BCS model, 1.95 V, and 105°C .

3.5.1.2 DDR_TYPE = 01 SDRAM I/O DC Parameters

Table 16 shows the DC I/O parameters for SDRAM.

Table 16. SDRAM DC Electrical Characteristics

DC Electrical Characteristics	Symbol	Test Conditions	Min.	Typ.	Max.	Units	Notes
High-level output voltage	Voh	Ioh = Specified Drive (Ioh = -4, -8, -12, -16mA)	2.4	—	—	V	1
Low-level output voltage	Vol	Ioh = Specified Drive (Ioh = 4, 8, 12, 16mA)	—	—	0.4	V	1
High-level output current	I	Standard Drive	-4.0	—	—	mA	—
	Ioh	High Drive	-8.0				
	Ioh	Max. Drive	-12.0				
Low-level output current	I	Standard Drive	4.0	—	—	mA	—
	Iol	High Drive	8.0				
	Iol	Max. Drive	12.0				
High-level DC input voltage	VIH	—	2.0	—	3.6	V	—
Low-level DC input voltage	VIL	—	-0.3 V	—	0.8	V	
Input current (no pull-up/down)	IIN	VI = 0 VI = OVDD	—	—	150 80	nA	2, 3
High-impedance I/O supply current	Icc-ovdd	VI = OVDD or 0	—	—	1180	nA	2, 3
High-impedance core supply current	Icc-vddi	VI = VDD or 0	—	—	1220	nA	

Note:

1. Simulation circuit for parameters Voh and Vol for I/O cells is below
2. Minimum condition: bcs model, OVDD = 3.6 V, and -40 °C. Typical condition: typical model, OVDD = 3.3 V, and 25 °C. Maximum condition: wcs model, OVDD = 3.0 V, and 105 °C.
3. Typical condition: typical model, OVDD = 3.3 V, and 25 °C. Maximum condition: bcs model, OVDD = 3.6 V, and 105 °C.

3.5.1.3 DDR_TYPE = 10 Max Setting DDR I/O DC Parameters

Table 17 shows the I/O parameters for DDR2 (SSTL_18).

Table 17. DDR2 (SSTL_18) I/O DC Electrical Characteristics

DC Electrical Characteristics	Symbol	Test Conditions	Min.	Typ.	Max.	Units	Notes
High-level output voltage	Voh	—	OVDD - 0.28	—	—	V	—
Low-level output voltage	Vol	—	—	—	0.28	V	
Output min. source current	Iloh	—	-13.4	—	—	mA	1
Output min. sink current	Ilol	—	13.4	—	—	mA	2
DC input logic high	VIH(dc)	—	OVDD/2 + 0.125	—	OVDD + 0.3	V	—
DC input logic low	VIL(dc)	—	-0.3 V	—	OVDD/2 - 0.125	V	—

Table 17. DDR2 (SSTL_18) I/O DC Electrical Characteristics (continued)

DC Electrical Characteristics	Symbol	Test Conditions	Min.	Typ.	Max.	Units	Notes
DC input signal voltage(for differential signal)	Vin(dc)	—	-0.3	—	OVDD + 0.3	V	3
DC differential input voltage	Vid(dc)	—	0.25	—	OVDD+0.6	V	4
Termination voltage	Vtt	—	OVDD/2 - 0.04	OVDD/2	OVDD/2 + 0.04		5
Input current (no pull-up/down)	IIN	VI = 0 VI = OVDD	—	—	110 60	nA	9
High-impedance I/O supply current	Icc-ovdd	VI = OVDD or 0	—	—	980	nA	9
High-impedance core supply current	Icc-vddi	VI = VDD or 0	—	—	1210	nA	

Note:

- OVDD = 1.7 V; $V_{out} = 1.42$ V. $(V_{out}-OVDD)/IOH$ must be less than 21 W for values of V_{out} between OVDD and OVDD-0.28 V.
- OVDD = 1.7 V; $V_{out} = 280$ mV. V_{out}/IOL must be less than 21 W for values of V_{out} between 0 V and 280 mV. Simulation circuit for parameters V_{oh} and V_{ol} for I/O cells is below
- Vin(dc) specifies the allowable DC excursion of each differential input
- Vid(dc) specifies the input differential voltage required for switching. The minimum value is equal to Vih(dc) - Vil(dc).
- Vtt is expected to track OVDD/2.
- Minimum condition: BCS model, 1.95 V, and -40 °C. Typical condition: typical model, 1.8 V, and 25 °C. Maximum condition: wcs model, 1.65 V, and 105 °C.
- Typical condition: typical model, 1.8 V, and 25 °C. Maximum condition: BCS model, 1.95 V, and 105 °C.
- The JEDEC SSTL_18 specification (JESD8-15a) for a SSTL interface for class II operation supersedes any specification in this document.

3.5.2 GPIO I/O DC Parameters

Table 18 shows the I/O parameters for GPIO.

Table 18. GPIO DC Electrical Characteristics

DC Electrical Characteristics	Symbol	Test Conditions	Min.	Typ.	Max.	Units	Notes
High-level output voltage	Voh	Ioh=-1mA Ioh = Specified Drive	OVDD - 0.15 0.8 × OVDD	—	—	V	1
Low-level output voltage	Vol	Iol=1mA Iol=Specified Drive	—	—	0.15 0.2 × OVDD	V	1
High-level output current for slow mode	I Ioh	Voh=0.8 × OVDD Standard Drive High Drive Max. Drive	-2.0 -4.0 -8.0	—	—	mA	—
High-level output current for fast mode	I Ioh	Voh=0.8 × OVDD Standard Drive High Drive Max. Drive	-4.0 -6.0 -8.0	—	—	mA	—

Table 18. GPIO DC Electrical Characteristics (continued)

DC Electrical Characteristics	Symbol	Test Conditions	Min.	Typ.	Max.	Units	Notes
Low-level output current for slow mode	I	Voh=0.2 × OVDD		—	—	mA	—
		Standard Drive	2.0				
	Iol	High Drive Max. Drive	4.0 8.0				
Low-level output current for fast mode	I	Voh=0.2 × OVDD		—	—	mA	—
		Standard Drive	4.0				
	Iol	High Drive Max. Drive	6.0 8.0				
High-level DC input voltage	VIH	—	0.7 × OVDD	—	OVDD	V	—
Low-level DC input voltage	VIL	—	−0.3 V	—	0.3 × OVDD	V	
Input hysteresis	VHYS	OVDD = 3.3 V OVDD = 1.8V	370 290	—	420 320	mV	—
Schmitt trigger VT+	VT+	—	0.5 × OVDD	—	—	V	2
Schmitt trigger VT−	VT−	—	—	—	0.5 × OVDD	V	
Pull-up resistor (22 kΩ PU)	Rpu	Vi=0	18.5	22	25.6	KΩ	3
Pull-up resistor (47 kΩ PU)	Rpu	Vi=0	41	47	55	KΩ	
Pull-up resistor (100 kΩ PU)	Rpu	Vi=0	85	100	120	KΩ	
Pull-down resistor (100 kΩ PD)	Rpd	VI = OVDD	85	100	120	KΩ	
Input current (no pull-up/down)	IIN	VI = 0, OVDD = 3.3 V VI = OVDD = 3.3 V VI = 0, OVDD = 1.8 V VI = OVDD = 1.8 V	—	—	100 60 77 50	nA	4
Input current (22 kΩ PU)	IIN	VI = 0, OVDD = 3.3 V VI = OVDD = 3.3 V VI = 0, OVDD = 1.8 V VI = OVDD = 1.8 V	117 0.0001 64 0.0001	—	184 0.0001 104 0.0001	μA	

Table 18. GPIO DC Electrical Characteristics (continued)

DC Electrical Characteristics	Symbol	Test Conditions	Min.	Typ.	Max.	Units	Notes
Input current (47 kΩ PU)	IIN	VI = 0, OVDD = 3.3 V VI = OVDD = 3.3 V VI = 0, OVDD = 1.8 V VI = OVDD = 1.8 V	54 0.0001 30 0.0001	—	88 0.0001 49 0.0001	μA	4
Input current (100 kΩ PU)	IIN	VI = 0, OVDD = 3.3 V VI = OVDD = 3.3 V VI = 0, OVDD = 1.8 V VI = OVDD = 1.8 V	25 0.0001 14 0.0001	—	42 0.0001 23 0.0001	μA	
Input current (100 kΩ PD)	IIN	VI = 0, OVDD = 3.3 V VI = OVDD = 3.3 V VI = 0, OVDD = 1.8 V VI = OVDD = 1.8 V	25 0.0001 14 0.0001	—	42 0.001 23 0.0001	μA	
High-impedance I/O supply current	Icc-ovdd	VI = 0, OVDD = 3.3 V VI = OVDD = 3.3 V VI = 0, OVDD = 1.8 V VI = OVDD = 1.8 V	—	—	688 688 560 560	nA	4
High-impedance core supply current	Icc-vddi	VI = 0, OVDD = 3.3 V VI = OVDD = 3.3 V VI = 0, OVDD = 1.8 V VI = OVDD = 1.8 V	—	—	490 490 410 410	nA	

1. Simulation circuit for parameters Voh and Vol for I/O cells is below
2. Hysteresis of 250 mV is guaranteed over all operating conditions when hysteresis is enabled.
3. Minimum condition: bcs model, OVDD = 3.6 V / 1.95 V and -40 °C. Typical condition: typical model, OVDD = 3.3 V / 1.8 V, and 25 °C. Maximum condition: wcs model, OVDD = 3.0 V, and 105 °C.
4. Typical condition: typical model, OVDD=3.3 V / 1.8 V, and 25 °C. Maximum condition: bcs model, OVDD=3.6 V / 1.95 V, and 105 °C.

3.6 AC Electrical Characteristics

This section provides the AC parameters for slow and fast I/O.

Figure 3 shows the load circuit for output. Figure 4 through Figure 6 show the output transition time and propagation waveforms.

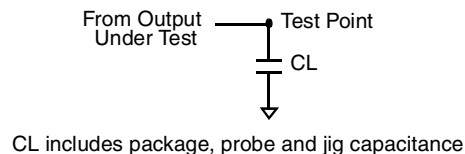

Figure 3. Load Circuit for Output

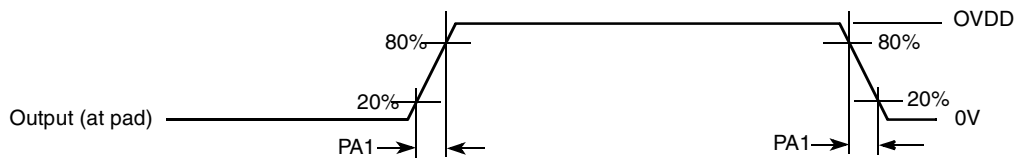

Figure 4. Output Pad Transition Time Waveform

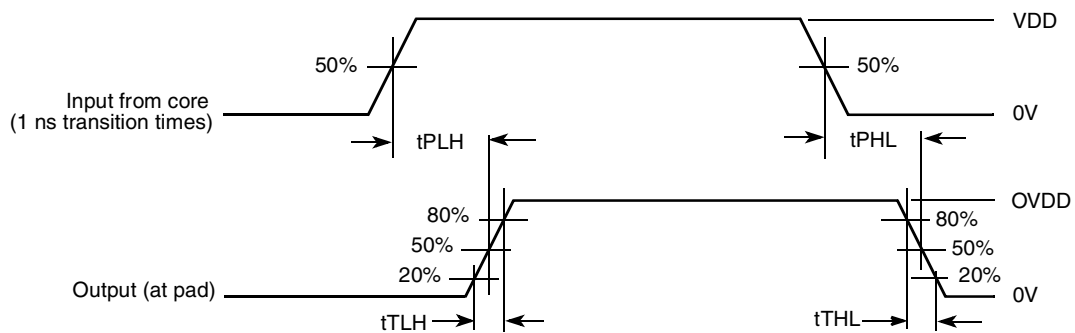

Figure 5. Output Pad Propagation and Transition Time Waveform

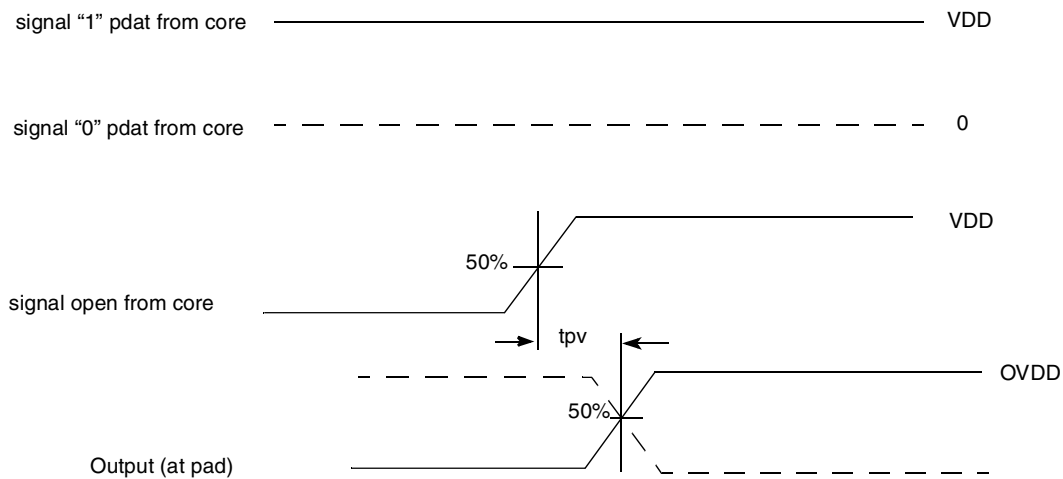

Figure 6. Output Enable to Output Valid

3.6.1 Slow I/O AC Parameters

Table 19 shows the slow I/O AC parameters.

Table 19. Slow I/O AC Parameters

Parameter	Symbol	Test Voltage	Test Capacitance	Min. Rise/Fall	Typ. Rise/Fall	Max. Rise/Fall	Units	Notes
Duty cycle	Fduty	—	—	40	—	60	%	—
Output pad transition times (max. drive)	tpr	3.0–3.6 V	25 pF	0.95/0.84	1.36/1.11	2.06/1.60	ns	1
		3.0–3.6 V	50 pF	1.58/1.37	2.19/1.77	3.20/2.47		
		1.65–1.95 V	25 pF	2.70/2.50	1.80/1.40	3.01/2.37		
		1.65–1.95 V	50 pF	3.40/3.20	2.80/2.14	4.63/3.38		
Output pad transition times (high drive)	tpr	3.0–3.6 V	25 pF	1.60/1.39	2.23/1.79	3.26/2.50		
		3.0–3.6 V	50 pF	2.94/2.51	4.05/3.17	5.72/4.27		
		1.65–1.95 V	25 pF	1.85/1.48	2.90/2.17	4.75/3.43		
		1.65–1.95 V	50 pF	2.93/2.37	4.56/3.40	7.33/5.26		
Output pad transition times (standard drive)	tpr	3.0–3.6 V	25 pF	3.07/2.62	4.22/3.30	6.03/4.48		
		3.0–3.6 V	50 pF	5.82/4.95	7.94/6.19	11.28/8.28		
		1.65–1.95 V	25 pF	3.04/2.47	4.73/3.50	3.01/2.36		
		1.65–1.95 V	50 pF	5.37/4.40	7.70/8.10	4.63/3.38		
Output pad propagation delay (max. drive), 50%–50%	tpo	3.0–3.6 V	25 pF	1.92/2.1	2.96/2.96	4.47/4.38	ns	1
		3.0–3.6 V	50 pF	2.44/2.53	3.7/3.64	5.54/5.31		
		1.65–1.95 V	25 pF	2.05/2.27	3.32/3.67	5.27/5.85		
		1.65–1.95 V	50 pF	2.71/2.84	4.39/4.51	7.00/7.15		
Output pad propagation delay (high drive), 50%–50%	tpo	3.0–3.6 V	25 pF	2.35/2.49	3.58/3.61	5.35/5.24		
		3.0–3.6 V	50 pF	3.31/3.43	4.9/4.786	7.19/6.8		
		1.65–1.95 V	25 pF	2.58/2.69	4.17/4.27	6.64/6.74		
		1.65–1.95 V	50 pF	3.62/3.60	5.86/5.61	9.34/8.76		
Output pad propagation delay (standard drive), 50%–50%	tpo	3.0–3.6 V	25 pF	3.39/3.51	5.03/4.89	7.39/6.95		
		3.0–3.6 V	50 pF	5.28/5.35	7.6/7.14	10.97/9.45		
		1.65–1.95 V	25 pF	3.71/3.68	6.03/5.75	9.64/8.97		
		1.65–1.95 V	50 pF	5.52/5.32	8.80/7.96	13.9/11.3		
Output pad propagation delay (max. drive), 40%–60%	tpo	3.0–3.6 V	25 pF	1.942/2.04	2.923/2.95	4.33/4.3	ns	1
		3.0–3.6 V	50 pF	2.378/2.48	3.541/3.53	5.29/5.09		
		1.65–1.95 V	25 pF	2.03/2.28	3.19/3.59	4.97/5.64		
		1.65–1.95 V	50 pF	2.59/2.73	4.10/4.33	6.43/6.77		
Output pad propagation delay (high drive), 40%–60%	tpo	3.0–3.6 V	25 pF	2.29/2.44	3.42/3.49	5.05/5.02		
		3.0–3.6 V	50 pF	3.05/3.20	4.46/4.45	6.53/6.3		
		1.65–1.95 V	25 pF	2.45/2.62	3.86/4.07	6.02/6.35		
		1.65–1.95 V	50 pF	3.36/3.39	5.34/5.22	8.40/8.08		
Output pad propagation delay (standard drive), 40%–60%	tpo	3.0–3.6 V	25 pF	3.12/3.26	4.58/4.53	6.69/6.42		
		3.0–3.6 V	50 pF	4.60/4.73	6.61/6.32	9.5/8.32		
		1.65–1.95 V	25 pF	3.43/3.46	5.48/5.34	8.65/8.26		
		1.65–1.95 V	50 pF	4.89/4.79	7.75/7.16	12.2/9.97		

Table 19. Slow I/O AC Parameters (continued)

Parameter	Symbol	Test Voltage	Test Capacitance	Min. Rise/Fall	Typ. Rise/Fall	Max. Rise/Fall	Units	Notes
Output enable to output valid delay (max. drive), 50%–50%	tpv	3.0–3.6 V	25 pF	2.13/2.01	3.3/3.045	5.072/4.609	ns	1
		3.0–3.6 V	50 pF	2.65/2.46	4.038/3.639	6.142/5.423		
		1.65–1.95 V	25 pF	2.31/2.45	3.76/4.00	6.11/6.47		
		1.65–1.95 V	50 pF	2.95/3.01	4.81/4.82	7.81/7.73		
Output enable to output valid delay (high drive), 50%–50%	tpv	3.0–3.6 V	25 pF	2.56/2.43	3.91/3.604	5.937/5.36		
		3.0–3.6 V	50 pF	3.55/3.21	5.21/4.598	7.776/6.694		
		1.65–1.95 V	25 pF	2.85/2.90	4.65/4.64	7.58/7.44		
		1.65–1.95 V	50 pF	3.87/3.78	6.31/5.95	10.3/9.43		
Output enable to output valid delay (standard drive), 50%–50%	tpv	3.0–3.6 V	25 pF	3.60/3.28	5.35/4.70	7.97/6.836		
		3.0–3.6 V	50 pF	5.50/4.81	7.93/6.603	11.58/9.338		
		1.65–1.95 V	25 pF	4.04/3.94	6.65/6.21	10.9/9.22		
		1.65–1.95 V	50 pF	5.85/5.56	9.47/8.49	15.5/13.3		
Output enable to output valid delay (max. drive), 40%–60%	tpv	3.0–3.6 V	25 pF	2.152/1.7	3.25/2.68	4.93/4.162	ns	1
		3.0–3.6 V	50 pF	2.6/2.07	3.88/3.17	5.842/4.846		
		1.65–1.95 V	25 pF	2.28/2.46	3.62/3.92	5.77/6.24		
		1.65–1.95 V	50 pF	2.83/2.93	4.50/4.62	7.20/7.32		
Output enable to output valid delay (high drive), 40%–60%	tpv	3.0–3.6 V	25 pF	2.497/2.036	3.75/3.135	5.633/4.782		
		3.0–3.6 V	50 pF	3.254/2.647	4.8/3.9	7.117/5.84		
		1.65–1.95 V	25 pF	2.71/2.81	4.31/4.23	6.89/7.01		
		1.65–1.95 V	50 pF	3.59/3.56	5.75/5.54	9.23/8.71		
Output enable to output valid delay (standard drive), 40%–60%	tpv	3.0–3.6 V	25 pF	3.326/2.7	4.9/3.9	7.269/5.95		
		3.0–3.6 V	50 pF	4.81/3.85	6.9/5.4	10.12/7.86		
		1.65–1.95 V	25 pF	3.73/3.69	6.04/5.77	9.81/9.11		
		1.65–1.95 V	50 pF	5.16/4.99	8.28/7.61	13.4/11.8		
Output pad slew rate (max. drive)	tps	3.0–3.6 V	25 pF	0.79/1.12	1.30/1.77	2.02/2.58	V/ns	2
		3.0–3.6 V	50 pF	0.49/0.73	0.84/1.23	1.19/1.58		
		1.65–1.95 V	25 pF	0.30/0.42	0.54/0.73	0.91/1.20		
		1.65–1.95 V	50 pF	0.20/0.29	0.35/0.50	0.60/0.80		
Output pad slew rate (high drive)	tps	3.0–3.6 V	25 pF	0.48/0.72	0.76/1.10	1.17/1.56		
		3.0–3.6 V	50 pF	0.27/0.42	0.41/0.62	0.63/0.86		
		1.65–1.95 V	25 pF	0.19/0.28	0.34/0.49	0.58/0.79		
		1.65–1.95 V	50 pF	0.12/0.18	0.34/0.49	0.36/0.49		
Output pad slew rate (standard drive)	tps	3.0–3.6 V	25 pF	0.25/0.40	0.40/0.59	0.60/0.83		
		3.0–3.6 V	50 pF	0.14/0.21	0.21/0.32	0.32/0.44		
		1.65–1.95 V	25 pF	0.12/0.18	0.20/0.30	0.34/0.47		
		1.65–1.95 V	50 pF	0.07/0.11	0.11/0.17	0.20/0.27		

Table 19. Slow I/O AC Parameters (continued)

Parameter	Symbol	Test Voltage	Test Capacitance	Min. Rise/Fall	Typ. Rise/Fall	Max. Rise/Fall	Units	Notes
Output pad dl/dt (max. drive)	tdit	3.0–3.6 V	25 pF	15	36	76	mA /ns	3
		3.0–3.6 V	50 pF	16	38	80		
		1.65–1.95 V	25 pF	7	21	56		
		1.65–1.95 V	50 pF	7	22	58		
Output pad dl/dt (high drive)	tdit	3.0–3.6 V	25 pF	8	20	45		
		3.0–3.6 V	50 pF	9	21	47		
		1.65–1.95 V	25 pF	5	14	38		
		1.65–1.95 V	50 pF	5	15	40		
Output pad dl/dt (standard drive)	tdit	3.0–3.6 V	25 pF	4	10	22		
		3.0–3.6 V	50 pF	4	10	23		
		1.65–1.95 V	25 pF	2	7	18		
		1.65–1.95 V	50 pF	2	7	19		
Input pad propagation delay without hysteresis, 50%–50%	tpi	—	1.6 pF	0.82/0.47 0.74/1	1.1/0.76 1.1/1.5	1.6/1.04 1.75/2.16	ns	4
Input pad propagation delay with hysteresis, 50%–50%	tpi	—	1.6 pF	1.1/1.3 1.75/1.63	1.43/1.6 2.67/2.22	2/2 2.92/3		
Input pad propagation delay without hysteresis, 40%–60%	tpi	—	1.6 pF	1.62/1.28 1.82/1.55	1.9/1.56 2.28/1.87	2.38/1.82 2.95/2.54		
Input pad propagation delay with hysteresis, 40%–60%	tpi	—	1.6 pF	1.88/2.1 2.4/2.6	2.2/2.4 3/3.07	2.7/2.75 3.77/3.71		
Input pad transition times without hysteresis	trfi	—	1.6 pF	0.16/0.12	0.23/0.18	0.33/0.29		
Input pad transition times with hysteresis	trfi	—	1.6 pF	0.16/0.13	0.22/0.18	0.33/0.29		
Maximum input transition times	trm	—	—	—	—	25		

Note:

1. Maximum condition for tpr, tpo, and tpv: wcs model, 1.1 V, I/O 3.0 V (3.0–3.6 V range) or 1.65 V (1.65–1.95 V range), and 105 °C. Minimum condition for tpr, tpo, and tpv: bcs model, 1.3 V, I/O 3.6 V (3.0–3.6 V range) or 1.95 V (1.65–1.95 V range), and –40 °C. Input transition time from core is 1 ns (20%–80%).
2. Minimum condition for tps: wcs model, 1.1 V, I/O 3.0 V (3.0–3.6 V range) or 1.65 V (1.65–1.95 V range), and 105 °C. tps is measured between VIL to VIH for rising edge and between VIH to VIL for falling edge.
3. Maximum condition for tdit: bcs model, 1.3 V, I/O 3.6 V (3.0–3.6 V range) or 1.95 V (1.65–1.95 V range), and –40 °C.
4. Maximum condition for tpi and trfi: wcs model, 1.1 V, I/O 3.0 V (3.0–3.6 V range) or 1.65 V (1.65–1.95 V range), and 105 °C. Minimum condition for tpi and trfi: bcs model, 1.3 V, I/O 3.6 V or 1.95 V (1.65–1.95 V range), and –40 °C. Input transition time from pad is 5 ns (20%–80%).
5. Hysteresis mode is recommended for input with transition time greater than 25 ns.

3.6.2 Fast I/O AC Parameters

Table 20 shows the fast I/O AC parameters for OVDD = 1.65–1.95 V.

Table 20. Fast I/O AC Parameters for OVDD = 1.65–1.95 V

Parameter	Symbol	Test Condition	Min. Rise/Fall	Typ.	Max. Rise/Fall	Units	Notes
Duty cycle	Fduty	—	40	—	60	%	—
Output pad transition times (max. drive)	tpr	25 pF 50 pF	0.88/0.77 1.45/1.24	1.36/1.10 2.20/1.80	2.10/1.70 3.50/2.70	ns	1
Output pad transition times (high drive)	tpr	25 pF 50 pF	1.10/0.92 1.84/1.54	1.65/1.33 2.80/2.20	2.64/2.10 4.40/3.30	ns	
Output pad transition times (standard drive)	tpr	25 pF 50 pF	1.60/1.35 2.74/2.26	2.47/1.95 4.20/3.20	3.99/3.10 6.56/4.86	ns	
Output pad propagation delay (max. drive), 50%–50%	tpo	25 pF 50 pF	1.64/1.53 2.15/2.01	2.68/2.41 3.47/3.08	4.25/3.74 5.50/4.77	ns	1
Output pad propagation delay (high drive), 50%–50%	tpo	25 pF 50 pF	1.82/1.71 2.46/2.29	2.98/2.66 3.96/3.49	4.74/4.13 6.27/5.37	ns	
Output pad propagation delay (standard drive), 50%–50%	tpo	25 pF 50 pF	2.24/2.06 3.17/2.92	3.63/3.15 5.09/4.41	5.73/4.84 8.06/6.75	ns	
Output pad propagation delay (max. drive), 40%–60%	tpo	25 pF 50 pF	1.67/1.58 2.09/1.98	2.63/2.38 3.30/2.97	4.06/3.63 5.14/4.51	ns	1
Output pad propagation delay (high drive), 40%–60%	tpo	25 pF 50 pF	1.94/1.73 2.34/2.22	2.89/2.61 3.69/3.30	4.49/3.97 5.76/5.01	ns	
Output pad propagation delay (standard drive), 40%–60%	tpo	25 pF 50 pF	2.15/1.99 2.94/2.74	3.39/2.99 4.65/4.07	5.28/4.53 7.28/6.13	ns	
Output enable to output valid delay (max. drive), 50%–50%	tpv	25 pF 50 pF	1.87/1.70 2.36/2.16	3.06/2.71 3.83/3.37	4.97/4.30 6.18/5.30	ns	1
Output enable to output valid delay (high drive), 50%–50%	tpv	25 pF 50 pF	2.05/1.88 2.68/2.45	3.67/2.98 4.32/3.78	5.46/4.72 6.98/5.92	ns	
Output enable to output valid delay (standard drive), 50%–50%	tpv	25 pF 50 pF	2.49/2.25 3.40/3.08	4.06/3.50 5.50/4.73	6.57/5.49 8.88/7.37	ns	
Output enable to output valid delay (max. drive), 40%–60%	tpv	25 pF 50 pF	1.90/1.74 2.30/2.13	3.00/2.69 3.65/3.24	4.76/4.18 5.79/5.02	ns	1
Output enable to output valid delay (high drive), 40%–60%	tpv	25 pF 50 pF	2.06/1.90 2.56/2.37	3.28/2.33 4.04/3.59	5.21/4.54 6.43/5.54	ns	
Output enable to output valid delay (standard drive), 40%–60%	tpv	25 pF 50 pF	2.39/2.18 3.16/2.89	3.80/3.18 5.03/4.37	6.05/5.14 8.02/6.72	ns	
Output pad slew rate (max. drive)	tps	25 pF 50 pF	0.40/0.57 0.25/0.36	0.72/0.97 0.43/0.61	1.2/1.5 0.72/0.95	V/ns	2
Output pad slew rate (high drive)	tps	25 pF 50 pF	0.38/0.48 0.20/0.30	0.59/0.81 0.34/0.50	0.98/1.27 0.56/0.72	V/ns	
Output pad slew rate (standard drive)	tps	25 pF 50 pF	0.23/0.32 0.13/0.20	0.40/0.55 0.23/0.34	0.66/0.87 0.38/0.52	V/ns	

Table 20. Fast I/O AC Parameters for OVDD = 1.65–1.95 V (continued)

Parameter	Symbol	Test Condition	Min. Rise/Fall	Typ.	Max. Rise/Fall	Units	Notes
Output pad dl/dt (max. drive)	tdit	25 pF 50 pF	7 7	43 46	112 118	mA/ns	3
Output pad dl/dt (high drive)	tdit	25 pF 50 pF	11 12	31 33	81 85	mA/ns	
Output pad dl/dt (standard drive)	tdit	25 pF 50 pF	9 10	27 28	71 74	mA/ns	
Input pad propagation delay without hysteresis, 50%–50%	tpi	1.6 pF	0.74/1	1.1/1.5	1.75/2.16	ns	4
Input pad propagation delay with hysteresis, 50%–50%	tpi	1.6 pF	1.75/1.63	2.67/2.22	2.92/3	ns	
Input pad propagation delay without hysteresis, 40%–60%	tpi	1.6 pF	1.82/1.55	2.28/1.87	2.95/2.54	ns	
Input pad propagation delay with hysteresis, 40%–60%	tpi	1.6 pF	2.4/2.6	3/3.07	3.77/3.71	ns	
Input pad transition times without hysteresis	trfi	1.6 pF	0.16/0.12	0.30/0.18	0.33/0.29	ns	
Input pad transition times with hysteresis	trfi	1.6 pF	0.16/0.13	0.30/0.18	0.33/0.29	ns	
Maximum input transition times	trm	—	—	—	25	ns	

Note:

1. Maximum condition for tpr, tpo, and tpv: wcs model, 1.1 V, I/O 1.65 V, and 105 °C. Minimum condition for tpr, tpo, and tpv: bcs model, 1.3 V, I/O 1.95 V, and –40 °C. Input transition time from core is 1 ns (20%–80%).
2. Minimum condition for tps: wcs model, 1.1 V, I/O 1.65 V and 105 °C. tps is measured between VIL to VIH for rising edge and between VIH to VIL for falling edge.
3. Maximum condition for tdit: bcs model, 1.3 V, I/O 1.95 V and –40 °C.
4. Maximum condition for tpi and trfi: wcs model, 1.1 V, I/O 1.65 V and 105 °C. Minimum condition for tpi and trfi: bcs model, 1.3 V, I/O 1.95 V and –40 °C. Input transition time from pad is 5 ns (20%–80%).
5. Hysteresis mode is recommended for input with transition time greater than 25 ns.

Table 21 shows the fast I/O AC parameters for OVDD = 3.0–3.6 V.

Table 21. Fast I/O AC Parameters for OVDD = 3.0–3.6 V

Parameter	Symbol	Test Condition	Min. Rise/Fall	Typ.	Max. Rise/Fall	Units	Notes
Duty Cycle	Fduty		40		60	%	
Output Pad Transition Times (Max Drive)	tpr	25 pF 50 pF	0.80/0.70 1.40/1.60	1.12/2.51 1.60/2.39	1.64/1.32 2.84/2.10	ns	1
Output Pad Transition Times (High Drive)	tpr	25 pF 50 pF	1.00/0.90 1.95/1.66	1.43/1.16 2.66/2.09	2.05/1.60 3.70/2.80	ns	
Output Pad Transition Times (Standard Drive)	tpr	25 pF 50 pF	1.50/1.30 2.90/2.50	2.09/1.67 3.40/3.09	3.00/2.30 5.56/4.12	ns	

Table 21. Fast I/O AC Parameters for OVDD = 3.0–3.6 V (continued)

Output Pad Propagation Delay (Max Drive), 50%–50%	tpo	25 pF 50 pF	1.20/1.28 1.67/1.75	1.74/1.73 2.39/2.32	2.67/2.52 3.58/3.33	ns	1
Output Pad Propagation Delay (High Drive), 50%–50%	tpo	25 pF 50 pF	1.35/1.42 1.98/2.04	1.95/1.91 2.81/2.68	2.96/2.76 4.16/3.78	ns	
Output Pad Propagation Delay (Standard Drive), 50%–50%	tpo	25 pF 50 pF	1.77/1.85 2.70/2.78	2.54/2.48 3.82/3.62	3.80/3.60 5.62/5.10	ns	
Output Pad Propagation Delay (Max Drive), 40%–60%	tpo	25 pF 50 pF	1.37/1.50 1.74/1.88	1.94/2.05 2.46/2.55	2.95/3.07 3.71/3.75	ns	1
Output Pad Propagation Delay (High Drive), 40%–60%	tpo	25 pF 50 pF	1.48/1.61 1.98/2.10	2.11/2.19 2.78/2.81	3.19/3.26 4.14/4.09	ns	
Output Pad Propagation Delay (Standard Drive), 40%–60%	tpo	25 pF 50 pF	1.84/1.97 2.58/2.71	2.61/2.67 3.62/3.58	3.95/3.95 5.36/5.15	ns	
Output Enable to Output Valid Delay (Max Drive), 50%–50%	tpv	25 pF 50 pF	1.34/1.32 1.81/1.79	1.91/1.81 2.56/2.40	2.92/2.67 3.83/3.47	ns	1
Output Enable to Output Valid Delay (High Drive), 50%–50%	tpv	25 pF 50 pF	1.48/1.47 2.12/2.1	2.12/2.00 2.98/2.76	3.21/2.92 4.41/3.94	ns	
Output Enable to Output Valid Delay (Standard Drive), 50%–50%	tpv	25 pF 50 pF	1.90/1.90 2.85/2.83	2.70/2.60 4.00/3.70	4.07/3.74 5.86/5.24	ns	
Output Enable to Output Valid Delay (Max Drive), 40%–60%	tpv	25 pF 50 pF	1.55/1.42 1.93/1.81	2.25/2.08 2.77/2.58	3.50/3.31 4.24/3.99	ns	1
Output Enable to Output Valid Delay (High Drive), 40%–60%	tpv	25 pF 50 pF	1.67/1.54 2.16/2.03	2.41/2.23 3.08/2.86	3.74/3.51 4.66/4.34	ns	
Output Enable to Output Valid Delay (Standard Drive), 40%–60%	tpv	25 pF 50 pF	2.02/1.90 2.76/2.63	2.91/2.71 3.91/3.62	4.48/4.21 5.85/5.39	ns	
Output Pad Slew Rate (Max Drive)	tps	25 pF 50 pF	0.96/1.40 0.54/0.83	1.54/2.10 0.85/1.24	2.30/3.00 1.26/1.70	V/ns	2
Output Pad Slew Rate (High Drive)	tps	25 pF 50 pF	0.76/1.10 0.41/0.64	1.19/1.71 0.63/0.95	1.78/2.39 0.95/1.30	V/ns	
Output Pad Slew Rate (Standard Drive)	tps	25 pF 50 pF	0.52/0.78 0.28/0.44	0.80/1.19 0.43/0.64	1.20/1.60 0.63/0.87	V/ns	
Output Pad di/dt (Max Drive)	didt	25 pF 50 pF	46 49	108 113	250 262	mA/ns	3
Output Pad di/dt (High Drive)	didt	25 pF 50 pF	35 37	82 86	197 207	mA/ns	
Output Pad di/dt (Standard Drive)	didt	25 pF 50 pF	22 23	52 55	116 121	mA/ns	

Table 21. Fast I/O AC Parameters for OVDD = 3.0–3.6 V (continued)

Input Pad Propagation Delay without Hysteresis, 50%–50%	t _{pi}	1.6pF	0.729/0.458	0.97/0.0649	1.404/0.97	ns	4
Input Pad Propagation Delay with Hysteresis, 50%–50%	t _{pi}	1.6pF	1.203/0.938	1.172/1.187	1.713/1.535	ns	
Input Pad Propagation Delay without Hysteresis, 40%–60%	t _{pi}	1.6pF	0.879/0.977	1.434/1.12	1.854/1.427	ns	
Input Pad Propagation Delay with Hysteresis, 40%–60%	t _{pi}	1.6pF	1.353/1.457	1.637/1.659	2.163/1.991	ns	
Input Pad Transition Times without Hysteresis	t _{r_{fi}}	1.6pF	0.16/0.12	0.23/0.18	0.33/0.29	ns	
Input Pad Transition Times with Hysteresis	t _{r_{fi}}	1.6pF	0.16/0.13	0.22/0.18	0.33/0.29	ns	
Maximum Input Transition Times	t _{rm}	—	—	—	—	ns	5

1. Maximum condition for t_{pr}, t_{po}, and t_{pv}: wcs model, 1.1 V, IO 3.0 V and 105 °C. Minimum condition for t_{pr}, t_{po}, and t_{pv}: bcs model, 1.3 V, IO 3.6 V and –40 °C. Input transition time from core is 1ns (20%–80%).
2. Minimum condition for t_{ps}: wcs model, 1.1 V, IO 3.0 V and 105 °C. t_{ps} is measured between VIL to VIH for rising edge and between VIH to VIL for falling edge.
3. Maximum condition for t_{dit}: bcs model, 1.3 V, IO 3.6 V and –40 °C.
4. Maximum condition for t_{pi} and t_{r_{fi}}: wcs model, 1.1 V, IO 3.0 V and 105 °C. Minimum condition for t_{pi} and t_{r_{fi}}: bcs model, 1.3 V, IO 3.6 V and –40 °C. Input transition time from pad is 5ns (20%–80%).
5. Hysteresis mode is recommended for input with transition time greater than 25 ns.

3.6.3 DDR I/O AC Parameters

The DDR pad type is configured by the IOMUXC_SW_PAD_CTL_GRP_DDRTYPE register (see Chapter 4, “External Signals and Pin Multiplexing,” in the *i.MX25 Multimedia Applications Processor Reference Manual*).

3.6.3.1 DDR_TYPE = 00 Standard Setting I/O AC Parameters and Requirements

Table 22 shows AC parameters for mobile DDR I/O. These settings are suitable for mDDR and DDR2 1.8V (± 5%) applications.

Table 22. AC Parameters for Mobile DDR I/O

Parameter	Symbol	Load Condition	Min. Rise/Fall	Typ.	Max. Rise/Fall	Units	Notes
Duty cycle	F _{duty}	—	40	50	60	%	—
Clock frequency	f	—	—	—	133	MHz	1
Output pad transition times (max. drive)	t _{pr}	25 pF 50 pF	0.52/0.51 0.98/0.96	0.79/0.72 1.49/1.34	1.25/1.09 2.31/1.98	ns	1
Output pad transition times (high drive)	t _{pr}	25 pF 50 pF	1.13/1.10 2.15/2.10	1.74/1.55 3.28/2.92	2.71/2.30 5.11/4.31	ns	
Output pad transition times (standard drive)	t _{pr}	25 pF 50 pF	2.26/2.19 4.30/4.18	3.46/3.07 6.59/5.79	5.39/4.56 10.13/8.55	ns	

Table 22. AC Parameters for Mobile DDR I/O (continued)

Parameter	Symbol	Load Condition	Min. Rise/Fall	Typ.	Max. Rise/Fall	Units	Notes
Output pad propagation delay (max. drive), 50%–50%	tpo	15 pF 35 pF	0.80/1.03 1.06/1.32	1.36/1.50 1.76/1.90	2.21/2.40 2.83/2.82	ns	1
Output pad propagation delay (high drive), 50%–50%	tpo	15 pF 35 pF	1.04/1.27 1.63/1.90	1.74/1.83 2.63/2.69	2.79/2.70 4.18/3.86	ns	
Output pad propagation delay (standard drive), 50%–50%	tpo	15 pF 35 pF	1.55/1.80 2.72/3.06	2.53/2.57 4.31/4.29	4.03/3.76 6.80/6.19	ns	
Output pad propagation delay (max. drive), 40%–60%	tpo	15 pF 35 pF	0.80/0.91 1.06/1.12	1.44/1.59 1.76/1.91	2.24/2.29 2.74/2.75	ns	1
Output pad propagation delay (high drive), 40%–60%	tpo	15 pF 35 pF	1.04/1.09 1.63/1.56	1.73/1.83 2.43/2.52	2.69/2.62 3.79/3.62	ns	
Output pad propagation delay (standard drive), 40%–60%	tpo	15 pF 35 pF	1.50/1.74 2.73/2.42	2.36/2.41 3.77/3.78	3.67/3.46 5.86/5.37	ns	
Output enable to output valid delay (max. drive), 50%–50%	tpv	15 pF 35 pF	1.17/1.01 1.43/1.30	1.93/1.61 2.33/2.00	3.06/2.55 3.69/3.13	ns	1
Output enable to output valid delay (high drive), 50%–50%	tpv	15 pF 35 pF	1.38/1.28 1.97/1.92	2.25/1.99 3.16/2.86	3.58/3.10 5.01/4.39	ns	
Output enable to output valid delay (standard drive), 50%–50%	tpv	15 pF 35 pF	1.92/1.57 3.12/3.16	3.11/2.79 4.97/4.59	4.98/4.13 7.97/6.98	ns	
Output enable to output valid delay (max. drive), 40%–60%	tpv	15 pF 35 pF	1.28/1.12 1.49/1.36	2.01/1.70 2.33/2.01	3.09/2.60 3.60/3.06	ns	1
Output enable to output valid delay (high drive), 40%–60%	tpv	15 pF 35 pF	1.43/1.33 1.90/1.84	2.24/1.99 2.96/2.68	3.47/3.02 4.59/4.03	ns	
Output enable to output valid delay (standard drive), 40%–60%	tpv	15 pF 35 pF	1.85/1.78 2.80/2.81	2.91/2.62 4.37/4.53	4.54/3.96 6.88/6.05	ns	
Output pad slew rate (max. drive)	tps	25 pF 50 pF	0.80/0.92 0.43/0.50	1.35/1.50 0.72/0.81	2.23/2.27 1.66/1.68	V/ns	2
Output pad slew rate (high drive)	tps	25 pF 50 pF	0.37/0.43 0.19/0.23	0.62/0.70 0.33/0.37	1.03/1.05 0.75/0.77	V/ns	
Output pad slew rate (standard drive)	tps	25 pF 50 pF	0.18/0.22 0.10/0.12	0.31/0.35 0.16/0.18	0.51/0.53 0.38/0.39	V/ns	
Output pad dl/dt (max. drive)	tdit	25 pF 50 pF	64 69	171 183	407 432	mA/ns	3
Output pad dl/dt (high drive)	tdit	25 pF 50 pF	37 39	100 106	232 246	mA/ns	
Output pad di/dt (standard drive)	tdit	25 pF 50 pF	18 20	50 52	116 123	mA/ns	
Input pad transition times	trfi	1.0 pF	0.07/0.08	0.11/0.13	0.16/0.20	ns	4
Input pad propagation delay, 50%–50%	tpi	1.0 pF	0.77/1.00	1.22/1.45	1.89/2.21	ns	
Input pad propagation delay, 40%–60%	tpi	1.0 pF	1.59/1.82	2.04/2.27	2.69/3.01	ns	

Note:

1. Maximum condition for tpr, tpo, tpi, and tpv: wcs model, 1.1 V, I/O 1.65 V, and 105 °C. Minimum condition for tpr, tpo, and tpv: bcs model, 1.3 V, I/O 1.95 V and –40 °C. Input transition time from core is 1 ns (20%–80%).
2. Minimum condition for tps: wcs model, 1.1 V, I/O 1.65 V, and 105 °C. tps is measured between VIL to VIH for rising edge and between VIH to VIL for falling edge.
3. Maximum condition for tdit: bcs model, 1.3 V, I/O 1.95 V, and –40 °C.
4. Maximum condition for tpi and trfi: wcs model, 1.1 V, I/O 1.65 V and 105 °C. Minimum condition for tpi and trfi: bcs model, 1.3 V, I/O 1.95 V and –40 °C. Input transition time from pad is 5 ns (20%–80%).

Table 23 shows the AC parameters for mobile DDR pbijtov18_33_ddr_clk I/O.

Table 23. AC Parameters for Mobile DDR pbijtov18_33_ddr_clk I/O

Parameter	Symbol	Load Condition	Min. Rise/Fall	Typ.	Max. Rise/Fall	Units	Notes
Duty cycle	Fduty	—	40	50	60	%	—
Clock frequency	f	—	—	—	133	MHz	1
Output pad transition times (max. drive)	tpr	25 pF 50 pF	0.52/0.51 0.98/0.96	0.79/0.72 1.49/1.34	1.25/1.09 2.31/1.98	ns	1
Output pad transition times (high drive)	tpr	25 pF 50 pF	1.13/1.10 2.15/2.10	1.74/1.55 3.28/2.92	2.71/2.30 5.11/4.31	ns	
Output pad transition times (standard drive)	tpr	25 pF 50 pF	2.26/2.19 4.30/4.18	3.46/3.07 6.59/5.79	5.39/4.56 10.13/8.55	ns	
Output pad propagation delay (max. drive), 50%–50% input signals and crossing of output signals	tpo	15 pF 35 pF	1.28/1.19 1.56/1.47	1.97/1.83 2.37/2.23	2.98/2.78 3.57/3.37	ns	1
Output pad propagation delay (high drive), 50%–50% input signals and crossing of output signals	tpo	15 pF 35 pF	1.54/1.43 2.14/2.04	2.34/2.20 3.22/3.08	3.54/3.33 4.85/4.65	ns	
Output pad propagation delay (standard drive), 50%–50% input signals and crossing of output signals	tpo	15 pF 35 pF	2.05/1.94 3.27/3.16	3.11/2.96 4.86/4.72	4.70/4.50 7.33/7.12	ns	
Output pad propagation delay (max. drive), 40%–60% input signals and crossing of output signals	tpo	15 pF 35 pF	1.45/1.36 1.73/1.64	2.13/2.00 2.53/2.40	3.14/2.94 3.74/3.54	ns	1
Output pad propagation delay (high drive), 40%–60% input signals and crossing of output signals	tpo	15 pF 35 pF	1.70/1.60 2.31/2.21	2.51/2.37 3.38/3.24	3.70/3.50 5.02/4.82	ns	
Output pad propagation delay (standard drive), 40%–60% input signals and crossing of output signals	tpo	15 pF 35 pF	2.22/2.11 3.43/3.32	3.27/3.13 5.02/4.88	4.87/4.66 7.49/7.29	ns	
Output enable to output valid delay (max. drive), 50%–50%	tpv	15 pF 35 pF	1.16/1.12 1.42/1.41	1.91/1.81 2.31/2.20	3.10/2.89 3.72/3.47	ns	1
Output enable to output valid delay (high drive), 50%–50%	tpv	15 pF 35 pF	1.39/1.39 1.98/2.02	2.28/2.18 3.18/3.04	3.69/3.43 5.08/4.69	ns	
Output enable to output valid delay (standard drive), 50%–50%	tpv	15 pF 35 pF	1.90/1.94 3.07/3.20	3.09/2.94 4.88/4.66	4.95/4.55 7.73/7.05	ns	

Table 23. AC Parameters for Mobile DDR pbijtov18_33_ddr_clk I/O (continued)

Parameter	Symbol	Load Condition	Min. Rise/Fall	Typ.	Max. Rise/Fall	Units	Notes
Output enable to output valid delay (max. drive), 40%–60%	tpv	15 pF 35 pF	1.28/1.24 1.49/1.47	2.00/1.90 2.32/2.21	3.14/2.93 3.64/3.41	ns	1
Output enable to output valid delay (high drive), 40%–60%	tpv	15 pF 35 pF	1.45/1.44 1.92/1.95	2.28/2.19 2.99/2.87	3.60/3.36 4.69/4.36	ns	
Output enable to output valid delay (standard drive), 40%–60%	tpv	15 pF 35 pF	1.85/1.88 2.78/2.88	2.92/2.79 4.34/4.16	4.58/4.25 6.79/6.24	ns	
Output pad slew rate (max. drive)	tps	25 pF 50 pF	0.37/0.45 0.30/0.36	0.64/0.79 0.52/0.61	1.14/1.36 0.90/1.02	V/ns	2
Output pad slew rate (high drive)	tps	25 pF 50 pF	0.30/0.37 0.21/0.25	0.51/0.63 0.36/0.42	0.91/1.06 0.63/0.67	V/ns	
Output pad slew rate (standard drive)	tps	25 pF 50 pF	0.22/0.26 0.13/0.16	0.37/0.44 0.23/0.26	0.65/0.72 0.39/0.40	V/ns	
Output pad dl/dt (max. drive)	tdit	25 pF 50 pF	65 70	171 183	426 450	mA/ns	3
Output pad dl/dt (high drive)	tdit	25 pF 50 pF	31 33	82 87	233 245	mA/ns	
Output pad dl/dt (standard drive)	tdit	25 pF 50 pF	16 17	43 46	115 120	mA/ns	
Input pad transition times	trfi	1.0 pF	0.07/0.08	0.11/0.13	0.16/0.20	ns	4
Input pad propagation delay, 50%–50%	tpi	1.0 pF	0.84/0.84	1.40/1.34	2.25/2.16	ns	
Input pad propagation delay, 40%–60%	tpi	1.0 pF	1.66/1.66	2.22/2.16	3.06/2.97	ns	

Note:

1. Maximum condition for tpr, tpo, tpi, and tpv: wcs model, 1.1 V, I/O 1.65 V, and 105 °C. Minimum condition for tpr, tpo, and tpv: bcs model, 1.3 V, I/O 1.95 V and –40 °C. Input transition time from core is 1 ns (20%–80%).
2. Minimum condition for tps: wcs model, 1.1 V, I/O 1.65 V, and 105 °C. tps is measured between VIL to VIH for rising edge and between VIH to VIL for falling edge.
3. Maximum condition for tdit: bcs model, 1.3 V, I/O 1.95 V, and –40 °C.
4. Maximum condition for tpi and trfi: wcs model, 1.1 V, I/O 1.65 V and 105 °C. Minimum condition for tpi and trfi: bcs model, 1.3 V, I/O 1.95 V and –40 °C. Input transition time from pad is 5 ns (20%–80%).

Table 24 shows the AC requirements for mobile DDR I/O.

Table 24. AC Requirements for Mobile DDR I/O

Parameter	Symbol	Min.	Max.	Units
AC input logic high	VIH(ac)	$0.8 \times \text{OVDD}$	$\text{OVDD}+0.3$	V
AC input logic low	VIL(ac)	–0.3	$0.2 \times \text{OVDD}$	V
AC differential input voltage	Vid(ac)	$0.6 \times \text{OVDD}$	$\text{OVDD}+0.6$	V
AC differential cross point voltage for input	Vix(ac)	$0.4 \times \text{OVDD}$	$\text{OVDD}+0.6$	V

3.6.3.2 DDR_TYPE = 01 SDRAM I/O AC Parameters and Requirements

Table 25 shows AC parameters for SDRAM I/O.

Table 25. AC Parameters for SDRAM I/O

Parameter	Symbol	Load Condition	Min. Rise/Fall	Typ.	Max. Rise/Fall	Units	Notes
Duty cycle	Fduty	—	40	50	60	%	—
Clock frequency	f	—	—	—	125	MHz	1
Output pad transition times (max. drive)	tp _r	25 pF 50 pF	0.82/0.87 1.56/1.67	1.14/1.13 2.13/2.09	1.62/1.50 3.015/2.77	ns	1
Output pad transition times (high drive)	tp _r	25 pF 50 pF	1.23/1.31 2.31/2.47	1.71/1.68 3.22/3.12	2.39/2.22 4.53/4.16	ns	
Output pad transition times (standard drive)	tp _r	25 pF 50 pF	2.44/2.60 4.65/4.99	3.38/3.27 6.38/6.23	4.73/4.38 9.05/8.23	ns	
Output pad propagation delay (max. drive), 50%–50%	tp _o	15 pF 35 pF	0.97/1.19 2.85/3.21	1.69/0.75 2.02/2.30	2.17/2.46 2.93/3.27	ns	1
Output pad propagation delay (high drive), 50%–50%	tp _o	15 pF 35 pF	1.15/1.39 3.57/3.91	1.72/1.93 2.54/2.85	2.51/2.77 3.66/3.97	ns	
Output pad propagation delay (standard drive), 50%–50%	tp _o	15 pF 35 pF	2.01/1.57 5.73/6.05	2.45/2.69 4.10/4.51	3.54/3.77 5.84/6.13	ns	
Output pad propagation delay (max. drive), 40%–60%	tp _o	15 pF 35 pF	1.06/1.26 1.38/1.38	1.53/1.73 1.96/2.23	2.18/2.47 2.78/3.12	ns	1
Output pad propagation delay (high drive), 40%–60%	tp _o	15 pF 35 pF	1.15/1.20 1.75/1.67	1.72/1.93 2.37/2.66	2.45/2.71 3.35/3.67	ns	
Output pad propagation delay (standard drive), 40%–60%	tp _o	15 pF 35 pF	1.91/2.01 2.88/2.56	2.30/2.52 3.59/3.97	3.26/3.50 5.06/5.36	ns	
Output enable to output valid delay (max. drive), 50%–50%	tp _v	15 pF 35 pF	0.90/1.27 1.07/1.77	1.44/1.89 1.66/2.51	2.19/2.87 2.51/3.69	ns	1
Output enable to output valid delay (high drive), 50%–50%	tp _v	15 pF 35 pF	1.01/1.48 1.37/2.33	1.58/2.16 2.06/3.09	2.38/3.23 3.06/4.46	ns	
Output enable to output valid delay (standard drive), 50%–50%	tp _v	15 pF 35 pF	1.32/2.14 2.04/3.67	2.02/3.00 3.00/4.91	3.01/4.36 4.40/6.90	ns	
Output enable to output valid delay (max. drive), 40%–60%	tp _v	15 pF 35 pF	1.03/1.34 1.16/1.74	1.54/1.94 1.74/2.44	2.26/2.88 2.55/3.54	ns	—
Output enable to output valid delay (high drive), 40%–60%	tp _v	15 pF 35 pF	1.11/1.51 1.39/2.10	1.65/2.15 2.03/2.89	2.43/3.16 2.95/4.13	ns	
Output enable to output valid delay (standard drive), 40%–60%	tp _v	15 pF 35 pF	1.35/2.03 1.91/3.23	1.99/2.83 2.76/4.30	2.89/4.03 3.98/6.01	ns	

Table 25. AC Parameters for SDRAM I/O (continued)

Parameter	Symbol	Load Condition	Min. Rise/Fall	Typ.	Max. Rise/Fall	Units	Notes
Output pad slew rate (max. drive)	tps	25 pF 50 pF	1.11/1.20 0.97/0.65	1.74/1.75 0.92/0.94	2.42/2.46 1.39/1.30	V/ns	2
Output pad slew rate (high drive)	tps	25 pF 50 pF	0.76/0.80 0.40/0.43	1.16/1.19 0.61/0.63	1.76/1.66 0.93/0.87	V/ns	
Output pad slew rate (standard drive)	tps	25 pF 50 pF	0.38/0.41 0.20/0.22	0.59/0.60 0.31/0.32	0.89/0.82 0.47/0.43	V/ns	
Output pad dl/dt (max. drive)	tdit	25 pF 50 pF	89 94	198 209	398 421	mA/ns	3
Output pad dl/dt (high drive)	tdit	25 pF 50 pF	59 62	132 139	265 279	mA/ns	
Output pad dl/dt (standard drive)	tdit	25 pF 50 pF	29 31	65 69	132 139	mA/ns	
Input pad transition times	trfi	1.0 pF	0.07/0.08	0.11/0.12	0.16/0.20	ns	4
Input pad propagation delay, 50%–50%	tpi	1.0 pF	0.35/1.17	0.63/1.53	1.16/2.04	ns	
Input pad propagation delay, 40%–60%	tpi	—	1.18/1.99	1.45/2.35	1.97/2.85	—	

Note:

1. Maximum condition for tpr, tpo, tpi, and tpv: wcs model, 1.1 V, I/O 3.0 V, and 105 °C. Minimum condition for tpr, tpo, and tpv: bcs model, 1.3 V, I/O 3.6 V and –40 °C. Input transition time from core is 1 ns (20%–80%).
2. Minimum condition for tps: wcs model, 1.1 V, I/O 3.0 V, and 105 °C. tps is measured between VIL to VIH for rising edge and between VIH to VIL for falling edge.
3. Maximum condition for tdit: bcs model, 1.3 V, I/O 3.6 V, and –40 °C.
4. Maximum condition for tpi and trfi: wcs model, 1.1 V, I/O 3.0 V and 105 °C. Minimum condition for tpi and trfi: bcs model, 1.3 V, I/O 3.6 V and –40 °C. Input transition time from pad is 5 ns (20%–80%).

Table 26 shows AC parameters for SDRAM pbijtov18_33_ddr_clk I/O.

Table 26. AC Parameters for SDRAM pbijtov18_33_ddr_clk I/O

Parameter	Symbol	Load Condition	Min. Rise/Fall	Typ.	Max. Rise/Fall	Units	Notes
Duty cycle	Fduty	—	40	50	60	%	—
Clock frequency	f	—	—	—	125	MHz	1
Output pad transition times (max. drive)	tpr	25 pF 50 pF	0.82/0.87 1.56/1.67	1.14/1.13 2.13/2.09	1.62/1.50 3.015/2.77	ns	1
Output pad transition times (high drive)	tpr	25 pF 50 pF	1.23/1.31 2.31/2.47	1.71/1.68 3.22/3.12	2.39/2.22 4.53/4.16	ns	
Output pad transition times (standard drive)	tpr	25 pF 50 pF	2.44/2.60 4.65/4.99	3.38/3.27 6.38/6.23	4.73/4.38 9.05/8.23	ns	

Table 26. AC Parameters for SDRAM pbijtov18_33_ddr_clk I/O (continued)

Parameter	Symbol	Load Condition	Min. Rise/Fall	Typ.	Max. Rise/Fall	Units	Notes
Output pad propagation delay (max. drive), 50%–50% input signals and crossing of output signals	tpo	15 pF 35 pF	1.50/1.40 1.95/1.85	2.23/2.07 2.81/2.66	3.28/3.04 4.06/3.82	ns	1
Output pad propagation delay (high drive), 50%–50% input signals and crossing of output signals	tpo	15 pF 35 pF	1.69/1.59 2.35/2.25	2.48/2.32 3.35/3.19	3.63/3.38 4.80/4.56	ns	
Output pad propagation delay (standard drive), 50%–50% input signals and crossing of output signals	tpo	15 pF 35 pF	2.26/2.15 3.59/3.49	3.24/3.08 4.98/4.82	4.66/4.42 7.00/6.75	ns	
Output pad propagation delay (max. drive), 40%–60% input signals and crossing of output signals	tpo	15 pF 35 pF	1.67/1.57 2.11/2.02	2.39/2.24 2.97/2.82	3.45/3.21 4.23/3.99	ns	1
Output pad propagation delay (high drive), 40%–60% input signals and crossing of output signals	tpo	15 pF 35 pF	1.85/1.75 2.52/2.42	2.65/2.49 3.51/3.36	3.79/3.55 4.97/4.72	ns	
Output pad propagation delay (standard drive), 40%–60% input signals and crossing of output signals	tpo	15 pF 35 pF	2.42/2.32 3.76/3.66	3.40/3.25 5.15/4.99	4.83/4.59 7.17/6.92	ns	
Output enable to output valid delay (max. drive), 50%–50%	tpv	15 pF 35 pF	1.37/1.34 1.77/1.83	2.22/2.02 2.77/2.63	3.53/3.12 4.30/3.92	ns	1
Output enable to output valid delay (high drive), 50%–50%	tpv	15 pF 35 pF	1.55/1.56 2.15/2.29	2.46/2.30 3.28/3.21	3.87/3.47 5.02/4.67	ns	
Output enable to output valid delay (standard drive), 50%–50%	tpv	15 pF 35 pF	2.07/2.18 3.28/3.65	3.20/3.08 4.84/4.90	4.92/4.50 7.21/6.89	ns	
Output enable to output valid delay (max. drive), 40%–60%	tpv	15 pF 35 pF	1.46/1.42 1.77/1.81	2.28/2.07 2.71/2.56	3.54/3.13 4.15/3.78	ns	—
Output enable to output valid delay (high drive), 40%–60%	tpv	15 pF 35 pF	1.60/1.59 2.07/2.18	2.47/2.30 3.12/3.02	3.82/3.41 4.72/4.37	ns	
Output enable to output valid delay (standard drive), 40%–60%	tpv	15 pF 35 pF	2.01/2.09 2.96/3.26	3.05/2.91 4.34/4.37	4.64/4.23 6.45/6.13	ns	
Output pad slew rate (max. drive)	tps	25 pF 50 pF	1.11/1.20 0.60/0.65	1.74/1.75 0.93/0.95	2.63/2.48 1.39/1.29	V/ns	2
Output pad slew rate (high drive)	tps	25 pF 50 pF	0.75/0.81 0.40/0.43	1.16/1.18 0.62/0.64	1.76/1.65 0.94/0.87	V/ns	
Output pad slew rate (standard drive)	tps	25 pF 50 pF	0.38/0.41 0.20/0.22	0.59/0.61 0.31/0.32	0.89/0.83 0.47/0.43	V/ns	

Table 26. AC Parameters for SDRAM pbijtov18_33_ddr_clk I/O (continued)

Parameter	Symbol	Load Condition	Min. Rise/Fall	Typ.	Max. Rise/Fall	Units	Notes
Output pad dI/dt (max. drive)	tdit	25 pF 50 pF	89 95	202 213	435 456	mA/ns	3
Output pad dI/dt (high drive)	tdit	25 pF 50 pF	60 63	135 142	288 302	mA/ns	
Output pad dI/dt (standard drive)	tdit	25 pF 50 pF	29 31	67 70	144 150	mA/ns	
Input pad transition times	trfi	1.0 pF	0.07/0.08	0.11/0.12	0.16/0.20	ns	4
Input pad propagation delay, 50%–50%	tpi	1.0 pF	0.56/0.69	0.87/1.08	1.37/1.62	ns	
Input pad propagation delay, 40%–60%	tpi		1.38/1.51	1.68/1.89	2.18/2.42		

Note:

1. Maximum condition for tpr, tpo, tpi, and tpv: wcs model, 1.1 V, I/O 3.0 V, and 105 °C. Minimum condition for tpr, tpo, and tpv: bcs model, 1.3 V, I/O 3.6 V and –40 °C. Input transition time from core is 1 ns (20%–80%).
2. Minimum condition for tps: wcs model, 1.1 V, I/O 3.0 V, and 105 °C. tps is measured between VIH to VIL for rising edge and between VIH to VIL for falling edge.
3. Maximum condition for tdit: bcs model, 1.3 V, I/O 3.6 V, and –40 °C.
4. Maximum condition for tpi and trfi: wcs model, 1.1 V, I/O 3.0 V and 105 °C. Minimum condition for tpi and trfi: bcs model, 1.3 V, I/O 3.6 V and –40 °C. Input transition time from pad is 5 ns (20%–80%).

3.6.3.3 DDR_TYPE = 10 Max Setting I/O AC Parameters and Requirements

Table 27 shows AC parameters for DDR2 I/O.

Table 27. AC Parameters for DDR2 I/O

Parameter	Symbol	Load Condition	Min. Rise/Fall	Typ.	Max. Rise/Fall	Units	Notes
Duty cycle	Fduty	—	40	50	60	%	—
Clock frequency	f	—	—	—	133	MHz	—
Output pad transition times	tpr	25 pF 50 pF	0.53/0.52 1.01/0.98	0.80/0.72 1.49/1.34	1.19/1.04 2.21/1.90	ns	1
Output pad propagation delay, 50%–50%	tpo	25 pF 50 pF	0.93/1.25 1.26/1.54	1.56/1.70 2.07/2.19	2.52/2.53 3.29/3.24	ns	1
Output pad propagation delay, 40%–60%	tpo	25 pF 50 pF	1.01/1.17 1.27/1.53	1.60/1.75 2.00/2.14	2.49/2.52 3.11/3.10	ns	1
Output enable to output valid delay, 50%–50%	tpv	25 pF 50 pF	1.30/1.19 1.62/1.54	2.17/1.81 2.56/2.29	3.35/2.84 3.35/2.54	ns	1
Output enable to output valid delay, 40%–60%	tpv	25 pF 50 pF	1.39/1.27 1.64/1.55	2.13/1.86 2.62/2.23	3.38/2.83 4.14/2.38	ns	1
Output pad slew rate	tps	25 pF 50 pF	0.86/0.98 0.46/0.54	1.35/1.5 0.72/0.81	2.15/2.19 1.12/1.16	V/ns	2

Table 27. AC Parameters for DDR2 I/O (continued)

Parameter	Symbol	Load Condition	Min. Rise/Fall	Typ.	Max. Rise/Fall	Units	Notes
Output pad dl/dt	tdit	25 pF 50 pF	65 70	157 167	373 396	mA/ns	3
Input pad transition times	trfi	1.0 pF	0.07/0.08	0.10/0.12	0.17/0.20	ns	4
Input pad propagation delay, 50%–50%	tpi	1.0 pF	0.83/0.99	1.23/1.49	1.79/2.04	ns	
Input pad propagation delay, 40%–60%	tpi	1.0 pF	1.65/1.81	2.05/2.31	2.60/2.84	ns	

Note:

1. Maximum condition for tpr, tpo, tpi, and tpv: wcs model, 1.1 V, I/O 1. V, and 105 °C. Minimum condition for tpr, tpo, and tpv: bcs model, 1.3 V, I/O 1.9 V and –40 °C. Input transition time from core is 1 ns (20%–80%).
2. Minimum condition for tps: wcs model, 1.1 V, I/O 1.7 V, and 105 °C. tps is measured between VIL to VIH for rising edge and between VIH to VIL for falling edge.
3. Maximum condition for tdit: bcs model, 1.3 V, I/O 1.9 V, and –40 °C.
4. Maximum condition for tpi and trfi: wcs model, 1.1 V, I/O 1.7 V and 105 °C. Minimum condition for tpi and trfi: bcs model, 1.3 V, I/O 1.9 V and –40 °C. Input transition time from pad is 5 ns (20%–80%).

Table 28 shows AC parameters for DDR2 pbijtov18_33_ddr_clk I/O.

Table 28. AC Parameters for DDR2 pbijtov18_33_ddr_clk I/O

Parameter	Symbol	Load Condition	Min. Rise/Fall	Typ.	Max. Rise/Fall	Units	Notes
Duty cycle	Fduty	—	40	50	60	%	—
Clock frequency	f	—	—	—	133	MHz	—
Output pad transition times	tpr	25 pF 50 pF	0.53/0.52 1.01/0.98	0.80/0.72 1.49/1.34	1.19/1.04 2.21/1.90	ns	1
Output pad propagation delay, 50%–50% input signals and crossing of output signals	tpo	25 pF 50 pF	1.3/1.21 1.59/1.5	1.97/1.84 2.37/2.24	2.91/2.71 3.48/3.28	ns	1
Output pad propagation delay, 40%–60% input signals and crossing of output signals	tpo	25 pF 50 pF	1.47/1.38 1.75/1.67	2.13/2.00 2.54/2.40	3.072/2.87 3.65/3.45	ns	1
Output enable to output valid delay, 50%–50%	tpv	25 pF 50 pF	1.32/1.28 1.66/1.65	2.11/2.00 2.61/2.50	3.31/3.12 4.06/3.81	ns	1
Output enable to output valid delay, 40%–60%	tpv	25 pF 50 pF	1.40/1.37 1.67/1.66	2.16/2.06 2.56/2.45	3.30/3.13 3.89/3.67	ns	1
Output pad slew rate	tps	25 pF 50 pF	0.86/0.98 0.46/0.54	1.35/1.5 0.72/0.81	2.15/2.19 1.12/1.16	V/ns	2
Output pad dl/dt	tdit	25 pF 50 pF	72 77	172 183	400 422	mA/ns	3
Input pad transition times	trfi	1.0 pF	0.07/0.08	0.10/0.12	0.17/0.20	ns	4
Input pad propagation delay, 50%–50%	tpi	1.0 pF	0.89/0.87	1.41/1.37	2.16/2.07	ns	
Input pad propagation delay, 40%–60%	tpi	1.0 pF	1.71/1.69	2.22/2.18	2.98/2.88	ns	

Note:

1. Maximum condition for tpr, tpo, tpi, and tpv: wcs model, 1.1 V, I/O 1. V, and 105 °C. Minimum condition for tpr, tpo, and tpv: bcs model, 1.3 V, I/O 1.9 V and –40 °C. Input transition time from core is 1 ns (20%–80%).

2. Minimum condition for tps: wcs model, 1.1 V, I/O 1.7 V, and 105 °C. tps is measured between VIL to VIH for rising edge and between VIH to VIL for falling edge.
3. Maximum condition for tdit: bcs model, 1.3 V, I/O 1.9 V, and -40 °C.
4. Maximum condition for tpi and trfi: wcs model, 1.1 V, I/O 1.7 V and 105 °C. Minimum condition for tpi and trfi: bcs model, 1.3 V, I/O 1.9 V and -40 °C. Input transition time from pad is 5 ns (20%–80%).

Table 29 shows the AC requirements for DDR2 I/O.

Table 29. AC Requirements for DDR2 I/O

Parameter ¹	Symbol	Min.	Max.	Units
AC input logic high	VIH(ac)	OVDD/2 + 0.25	OVDD + 0.3	V
AC input logic low	VIL(ac)	-0.3	OVDD/2 - 0.25	V
AC differential input voltage ²	Vid(ac)	0.5	OVDD + 0.6	V
AC differential cross point voltage for input ³	Vix(ac)	OVDD/2-0.175	OVDD/2 + 0.175	V
AC differential cross point voltage for output ⁴	Vox(ac)	OVDD/2-0.125	OVDD/2 + 0.125	V

¹ Note that the Jedic SSTL_18 specification (JESD8-15a) for an SSTL interface for class II operation supersedes any specification in this document.

² Vid(ac) specifies the input differential voltage $|V_{tr} - V_{cp}|$ required for switching, where V_{tr} is the “true” input signal and V_{cp} is the “complementary” input signal. The minimum value is equal to $V_{ih}(ac) - V_{il}(ac)$

³ The typical value of $V_{ix}(ac)$ is expected to be about $0.5 \times OVDD$. and $V_{ix}(ac)$ is expected to track variation of OVDD. $V_{ix}(ac)$ indicates the voltage at which differential input signal must cross.

⁴ The typical value of $V_{ox}(ac)$ is expected to be about $0.5 \times OVDD$ and $V_{ox}(ac)$ is expected to track variation in OVDD. $V_{ox}(ac)$ indicates the voltage at which differential output signal must cross. Load = 25 pF.

3.7 Module Timing and Electrical Parameters

This section contains the timing and electrical parameters for i.MX25 modules.

3.7.1 1-Wire Timing Parameters

Figure 7 shows the reset and presence pulses (RPP) timing for 1-Wire.

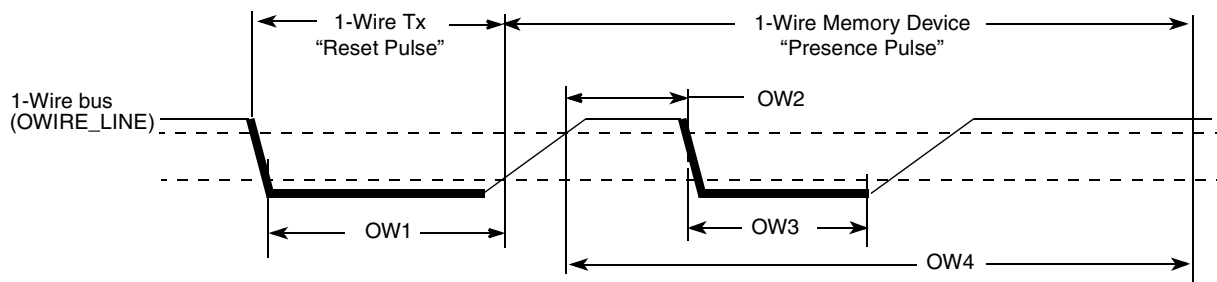

Figure 7. 1-Wire RPP Timing Diagram

Table 30 lists the RPP timing parameters.

Table 30. RPP Sequence Delay Comparisons Timing Parameters

ID	Parameters	Symbol	Min.	Typ.	Max.	Units
OW1	Reset Time Low	t_{RSTL}	480	511	—	us
OW2	Presence Detect High	t_{PDH}	15	—	60	us
OW3	Presence Detect Low	t_{PDL}	60	—	240	us
OW4	Reset Time High	t_{RSTH}	480	512	—	us

Figure 8 shows write 0 sequence timing, and Table 31 describes the timing parameters (OW5–OW6) that are shown in the figure.

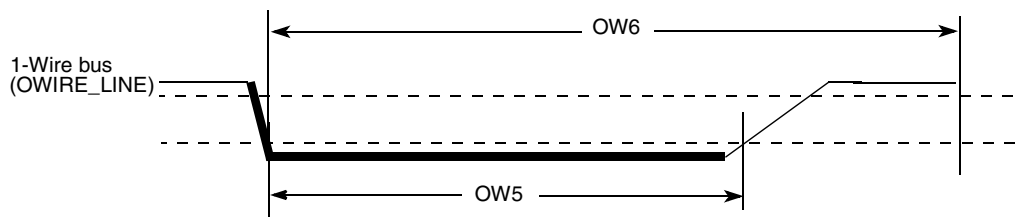

Figure 8. Write 0 Sequence Timing Diagram

Table 31. WR0 Sequence Timing Parameters

ID	Parameter	Symbol	Min.	Typ.	Max.	Units
OW5	Write 0 Low Time	t_{WR0_low}	60	100	120	μ s
OW6	Transmission Time Slot	t_{SLOT}	OW5	117	120	μ s

Figure 9 and Figure 10 show write 1 and read sequence timing, respectively. Table 32 describes the timing parameters (OW7–OW8) that are shown in the figure.

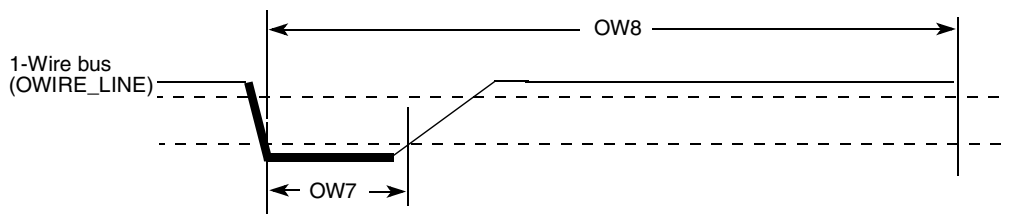

Figure 9. Write 1 Sequence Timing Diagram

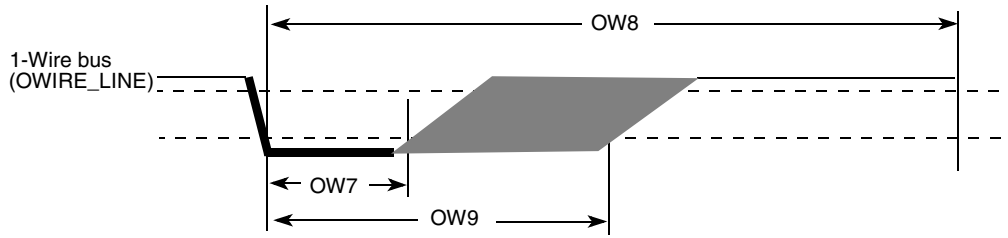

Figure 10. Read Sequence Timing Diagram

Table 32. WR1 /RD Timing Parameters

ID	Parameter	Symbol	Min.	Typ.	Max.	Units
OW7	Write 1 / read low time	t_{LOW1}	1	5	15	μs
OW8	Transmission time slot	t_{SLOT}	60	117	120	μs
OW9	Release time	$t_{RELEASE}$	15	—	45	μs

3.7.2 ATA Timing Parameters

Table 33 shows parameters used to specify the ATA timing. These parameters depend on the implementation of the ATA interface on silicon, the bus buffer used, the cable delay and cable skew.

Table 33. Timing Parameters

Name	Description	Value/Contributing Factor
T	Bus clock period	Peripheral clock frequency
ti_ds	Set-up time ata_data to ata_iordy edge (UDMA-in only) UDMA0 UDMA1 UDMA2,UDMA3 UDMA4 UDMA5	15 ns 10 ns 7 ns 5 ns 4 ns
ti_dh	Hold time ata_iordy edge to ata_data (UDMA-in only) UDMA0,UDMA1,UDMA2,UDMA3,UDMA4 UDMA5	5.0 ns 4.6 ns
tco	Propagation delay bus clock L-to-H to ata_cs0 , ata_cs1 , ata_da2 , ata_da1 , ata_da0 , ata_dior , ata_diow , ata_dmack , ata_data , ata_buffer_en	12.0 ns
tsu	Set-up time ata_data to bus clock L-to-H	8.5 ns
tsui	Set-up time ata_iordy to bus clock H-to-L	8.5 ns
thi	Hold time ata_iordy to bus clock H-to-L	2.5 ns
tskew1	Maximum difference in propagation delay bus clock L-to-H to any of the following signals ata_cs0 , ata_cs1 , ata_da2 , ata_da1 , ata_da0 , ata_dior , ata_diow , ata_dmack , ata_data (write), ata_buffer_en	7 ns

Table 33. Timing Parameters (continued)

Name	Description	Value/Contributing Factor
tskew2	Maximum difference in buffer propagation delay for any of the following signals ata_cs0, ata_cs1, ata_da2, ata_da1, ata_da0, ata_dior, ata_dioiw, ata_dmack, ata_data (write), ata_buffer_en	Transceiver
tskew3	Maximum difference in buffer propagation delay for any of the following signals ata_iordy, ata_data (read)	Transceiver
tbuf	Maximum buffer propagation delay	Transceiver
tcable1	cable propagation delay for ata_data	Cable
tcable2	cable propagation delay for control signals ata_dior, ata_dioiw, ata_iordy, ata_dmack	Cable
tskew4	Maximum difference in cable propagation delay between ata_iordy and ata_data (read)	Cable
tskew5	Maximum difference in cable propagation delay between (ata_dior, ata_dioiw, ata_dmack) and ata_cs0, ata_cs1, ata_da2, ata_da1, ata_da0, ata_data (write)	Cable
tskew6	Maximum difference in cable propagation delay without accounting for ground bounce	Cable

3.7.2.1 PIO Mode Timing Parameters

Figure 11 shows a timing diagram for PIO read mode.

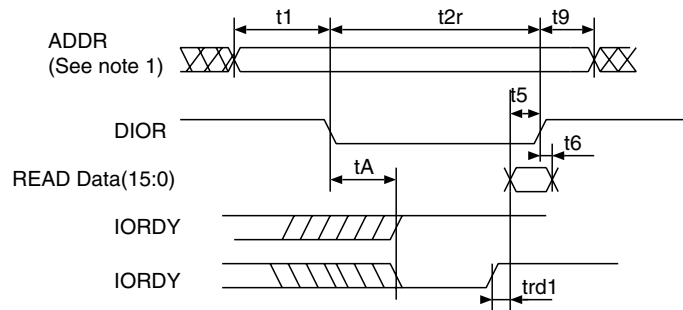

Figure 11. PIO Read Mode Timing

To meet PIO read mode timing requirements, a number of timing parameters must be controlled. Table 34 shows timing parameters and their determining relations, and indicates parameters that can be adjusted to meet required conditions.

Table 34. Timing Parameters for PIO Read Mode

ATA Parameter	PIO Read Mode Timing Parameter ¹	Relation	Adjustable Parameter
t1	t1	$t1(\text{min.}) = \text{time_1} \times T - (\text{tskew1} + \text{tskew2} + \text{tskew5})$	time_1
t2	t2r	$t2(\text{min.}) = \text{time_2r} \times T - (\text{tskew1} + \text{tskew2} + \text{tskew5})$	time_2r
t9	t9	$t9(\text{min.}) = \text{time_9} \times T - (\text{tskew1} + \text{tskew2} + \text{tskew6})$	time_9
t5	t5	$t5(\text{min.}) = \text{tco} + \text{tsu} + \text{tbuf} + \text{tbuf} + \text{tcable1} + \text{tcable2}$	If not met, increase time_2
t6	t6	0	—
tA	tA	$tA(\text{min.}) = (1.5 + \text{time_ax}) \times T - (\text{tco} + \text{tsui} + \text{tcable2} + \text{tcable2} + 2 \times \text{tbuf})$	time_ax
trd	trd1	$\text{trd1}(\text{max.}) = (-\text{trd}) + (\text{tskew3} + \text{tskew4})$ $\text{trd1}(\text{min.}) = (\text{time_pio_rdx} - 0.5) \times T - (\text{tsu} + \text{thi})$ $(\text{time_pio_rdx} - 0.5) \times T > \text{tsu} + \text{thi} + \text{tskew3} + \text{tskew4}$	time_pio_rdx
t0	—	$t0(\text{min.}) = (\text{time_1} + \text{time_2} + \text{time_9}) \times T$	time_1, time_2r, time_9

¹ See Figure 11.

Figure 12 gives timing waveforms for PIO write mode.

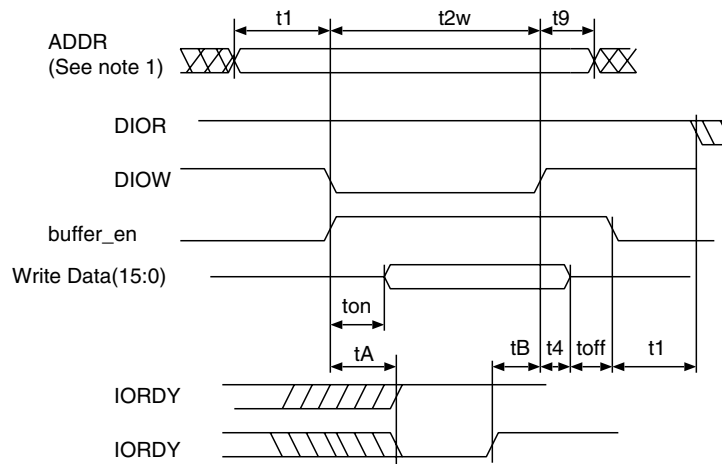

Figure 12. PIO Write Mode Timing

To meet PIO write mode timing requirements, a number of timing parameters must be controlled. Table 35 shows timing parameters and their determining relations, and indicates parameters that can be adjusted to meet required conditions.

Table 35. Timing Parameters for PIO Write Mode

ATA Parameter	PIO Write Mode Timing Parameter ¹	Relation	Adjustable Parameter(s)
t1	t1	$t1(\text{min.}) = \text{time_1} \times T - (\text{tskew1} + \text{tskew2} + \text{tskew5})$	time_1
t2	t2w	$t2(\text{min.}) = \text{time_2w} \times T - (\text{tskew1} + \text{tskew2} + \text{tskew5})$	time_2w
t9	t9	$t9(\text{min.}) = \text{time_9} \times T - (\text{tskew1} + \text{tskew2} + \text{tskew6})$	time_9
t3	—	$t3(\text{min.}) = (\text{time_2w} - \text{time_on}) \times T - (\text{tskew1} + \text{tskew2} + \text{tskew5})$	if not met, increase time_2w
t4	t4	$t4(\text{min.}) = \text{time_4} \times T - \text{tskew1}$	time_4
tA	tA	$tA = (1.5 + \text{time_ax}) \times T - (\text{tco} + \text{tsui} + \text{tcable2} + \text{tcable2} + 2 \times \text{tbuf})$	time_ax
t0	—	$t0(\text{min.}) = (\text{time_1} + \text{time_2} + \text{time_9}) \times T$	time_1, time_2r, time_9
—	—	Avoid bus contention when switching buffer on by making ton long enough	—
—	—	Avoid bus contention when switching buffer off by making toff long enough	—

¹ See Figure 12.

3.7.2.2 Multiword DMA (MDMA) Mode Timing

Figure 13 and Figure 14 show the timing for MDMA read and write modes, respectively.

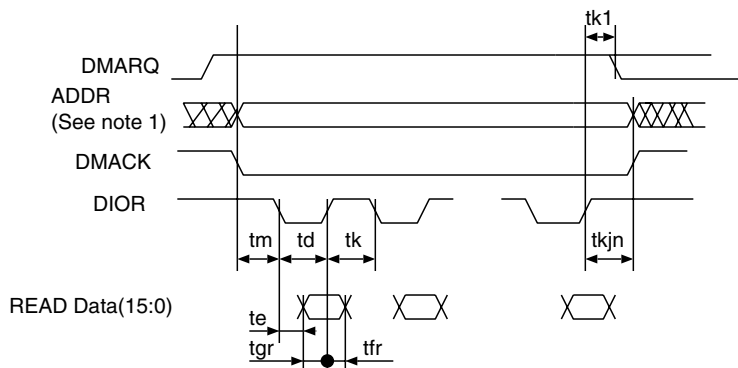

Figure 13. MDMA Read Mode Timing

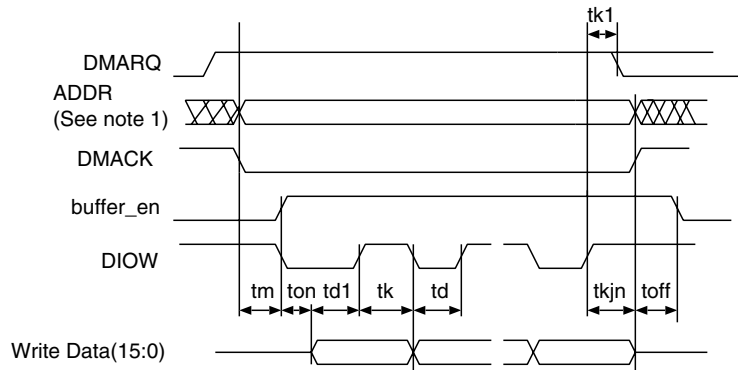

Figure 14. MDMA Write Mode Timing

To meet timing requirements, a number of timing parameters must be controlled. See [Table 36](#) for details on timing parameters for MDMA read and write modes.

Table 36. Timing Parameters for MDMA Read and Write Modes

ATA Parameter	MDMA Read ¹ and Write ² Timing Parameters	Relation	Adjustable Parameter(s)
tm, ti	tm	$tm(\text{min.}) = ti(\text{min.}) = \text{time_m} \times T - (\text{tskew1} + \text{tskew2} + \text{tskew5})$	time_m
td	td, td1	$td1(\text{min.}) = td(\text{min.}) = \text{time_d} \times T - (\text{tskew1} + \text{tskew2} + \text{tskew6})$	time_d
tk	tk	$tk(\text{min.}) = \text{time_k} \times T - (\text{tskew1} + \text{tskew2} + \text{tskew6})$	time_k
t0	—	$t0(\text{min.}) = (\text{time_d} + \text{time_k}) \times T$	time_d, time_k
tg(read)	tgr	$tgr(\text{min.}-\text{read}) = \text{tco} + \text{tsu} + \text{tbuf} + \text{tbuf} + \text{tcable1} + \text{tcable2}$ $tgr(\text{min.}-\text{drive}) = \text{td} - \text{te}(\text{drive})$	time_d
tf(read)	tfr	$tfr(\text{min.}-\text{drive}) = 0 \text{ k}$	—
tg(write)	—	$tg(\text{min.}-\text{write}) = \text{time_d} \times T - (\text{tskew1} + \text{tskew2} + \text{tskew5})$	time_d
tf(write)	—	$tf(\text{min.}-\text{write}) = \text{time_k} \times T - (\text{tskew1} + \text{tskew2} + \text{tskew6})$	time_k
tL	—	$tL(\text{max.}) = (\text{time_d} + \text{time_k} - 2) \times T - (\text{tsu} + \text{tco} + 2 \times \text{tbuf} + 2 \times \text{tcable2})$	time_d, time_k ³
tn, tj	tkjn	$tn = tj = tkjn = (\text{max.}(\text{time_k}, \text{time_jn}) \times T - (\text{tskew1} + \text{tskew2} + \text{tskew6}))$	time_jn
—	ton toff	$\text{ton} = \text{time_on} \times T - \text{tskew1}$ $\text{toff} = \text{time_off} \times T - \text{tskew1}$	—

¹ See [Figure 13](#).

² See [Figure 14](#).

³ tk1 in the UDMA figures equals $(tk - 2 \times T)$.

3.7.2.3 Ultra DMA (UDMA) Mode Timing

UDMA mode timing is more complicated than PIO mode or MDMA mode. In this section, timing diagrams for UDMA in- and out-transfers are provided.

3.7.2.3.1 UDMA In-Transfer Timing

Figure 15 shows the timing for UDMA in-transfer start.

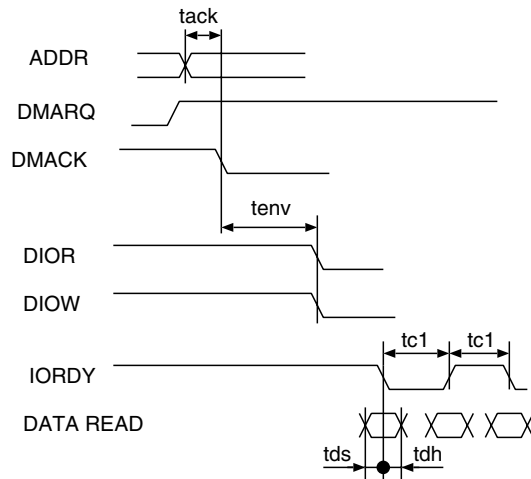

Figure 15. Timing for UDMA In-Transfer Start

Figure 16 shows the timing for host-terminated UDMA in-transfer.

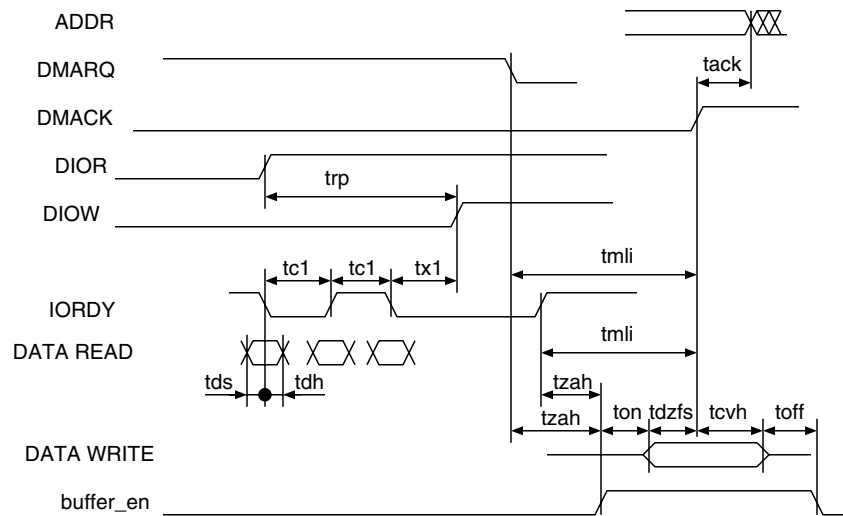

Figure 16. Timing for Host-Terminated UDMA In-Transfer

Figure 17 shows timing for device-terminated UDMA in-transfer.

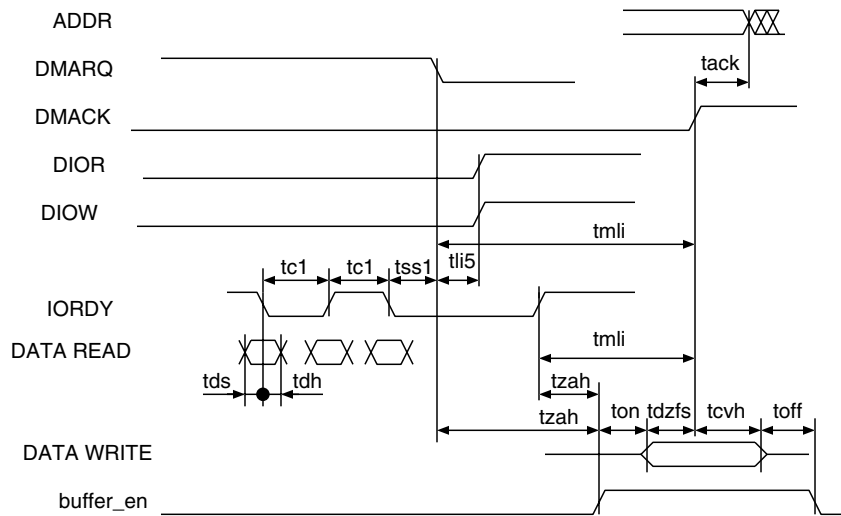

Figure 17. Timing for Device-Terminated UDMA Transfer

Timing parameters for UDMA in-burst are listed in Table 37.

Table 37. Timing Parameters for UDMA In-Burst

ATA Parameter	Spec. Parameter	Value	Required Conditions
tack	tack	$tack(\text{min.}) = (\text{time_ack} \times T) - (\text{tskew1} + \text{tskew2})$	time_ack
tenv	tenv	$tenv(\text{min.}) = (\text{time_env} \times T) - (\text{tskew1} + \text{tskew2})$ $tenv(\text{max.}) = (\text{time_env} \times T) + (\text{tskew1} + \text{tskew2})$	time_env
tds	tds1	$tds - (\text{tskew3}) - ti_ds > 0$	tskew3, ti_ds, ti_dh should be low enough
tdh	tdh1	$tdh - (\text{tskew3}) - ti_dh > 0$	
tcyc	tc1	$(\text{tcyc} - \text{tskew}) > T$	T big enough
trp	trp	$trp(\text{min.}) = \text{time_rp} \times T - (\text{tskew1} + \text{tskew2} + \text{tskew6})$	time_rp
—	tx1 ¹	$(\text{time_rp} \times T) - (\text{tco} + \text{tsu} + 3T + 2 \times \text{tbuf} + 2 \times \text{tcable2}) > \text{trfs} (\text{drive})$	time_rp
tmli	tmli1	$tmli1(\text{min.}) = (\text{time_mlix} + 0.4) \times T$	time_mlix
tzah	tzah	$tzah(\text{min.}) = (\text{time_zah} + 0.4) \times T$	time_zah
tdzfs	tdzfs	$tdzfs = (\text{time_dzfs} \times T) - (\text{tskew1} + \text{tskew2})$	time_dzfs
tcvh	tcvh	$tcvh = (\text{time_cvh} \times T) - (\text{tskew1} + \text{tskew2})$	time_cvh
—	ton toff	$ton = \text{time_on} \times T - \text{tskew1}$ $toff = \text{time_off} \times T - \text{tskew1}$	—

¹ There is a special timing requirement in the ATA host that requires the internal DIOw to go only high three clocks after the last active edge on the DSTROBE signal. The equation given on this line tries to capture this constraint.

Make t_{on} and t_{off} big enough to avoid bus contention.

3.7.2.4 UDMA Out-Transfer Timing

Figure 18 shows the timing for start of UDMA out-transfer.

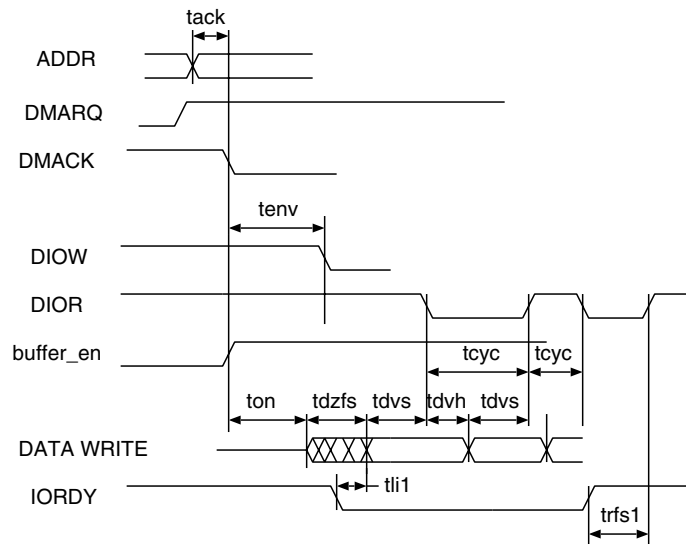

Figure 18. Timing for UDMA Out-Transfer Start

Figure 19 shows timing for host-terminated UDMA out-transfer.

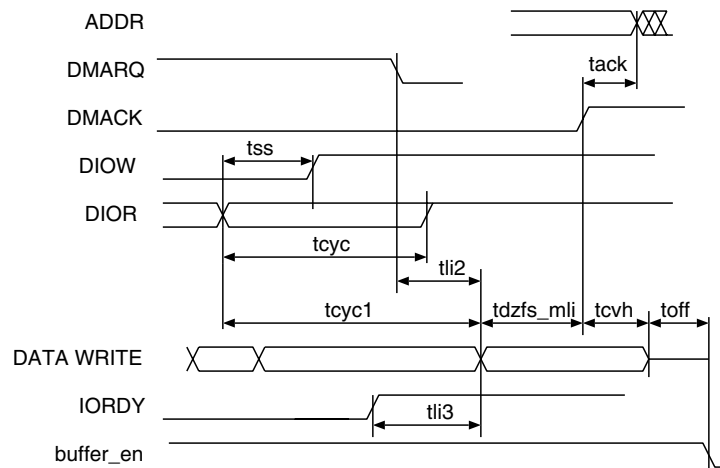

Figure 19. Timing for Host-Terminated UDMA Out-Transfer

Timing parameters for UDMA out-bursts are listed in [Table 38](#).

Table 38. Timing Parameters UDMA Out-Bursts

ATA Parameter	Spec Parameter	Value	How to Meet?
tack	tack	$tack(min.) = (time_ack \times T) - (tskew1 + tskew2)$	time_ack
tenv	tenv	$tenv(min.) = (time_env \times T) - (tskew1 + tskew2)$ $tenv(max.) = (time_env \times T) + (tskew1 + tskew2)$	time_env
tdvs	tdvs	$tdvs = (time_dvs \times T) - (tskew1 + tskew2)$	time_dvs
tdvh	tdvh	$tdvs = (time_dvh \times T) - (tskew1 + tskew2)$	time_dvh
tcyc	tcyc	$tcyc = time_cyc \times T - (tskew1 + tskew2)$	time_cyc
t2cyc	—	$t2cyc = time_cyc \times 2 \times T$	time_cyc
trfs1	trfs	$trfs = 1.6 \times T + tsui + tco + tbuf + tbuf$	—
—	tdzfs	$tdzfs = time_dzfs \times T - (tskew1)$	time_dzfs
tss	tss	$tss = time_ss \times T - (tskew1 + tskew2)$	time_ss
tmli	tdzfs_mli	$tdzfs_mli = \max(time_dzfs, time_mli) \times T - (tskew1 + tskew2)$	—
tli	tli1	$tli1 > 0$	—
tli	tli2	$tli2 > 0$	—
tli	tli3	$tli3 > 0$	—
tcvh	tcvh	$tcvh = (time_cvh \times T) - (tskew1 + tskew2)$	time_cvh
—	ton toff	$ton = time_on \times T - tskew1$ $toff = time_off \times T - tskew1$	—

3.7.3 Digital Audio Mux (AUDMUX) Timing

The AUDMUX provides a programmable interconnect logic for voice, audio, and data routing between internal serial interfaces (SSI and SAP) and external serial interfaces (audio and voice codecs). The AC timing of AUDMUX external pins is governed by the SSI modules. For more information, see [Section 3.7.17, “Synchronous Serial Interface \(SSI\) Timing.”](#)

3.7.4 CMOS Sensor Interface (CSI) Timing

The CSI enables the chip to connect directly to external CMOS image sensors, which are classified as dumb or smart as follows:

- Dumb sensors only support traditional sensor timing (vertical sync (VSYNC) and horizontal sync (HSYNC)) and output-only Bayer and statistics data.
- Smart sensors support CCIR656 video decoder formats and perform additional processing of the image (for example, image compression, image pre-filtering, and various data output formats).

The following subsections describe the CSI timing in gated and ungated clock modes.

3.7.4.1 Gated Clock Mode Timing

Figure 20 and Figure 21 shows the gated clock mode timings for CSI, and Table 39 describes the timing parameters (P1–P7) shown in the figures. A frame starts with a rising/falling edge on VSYNC, then HSYNC is asserted and holds for the entire line. The pixel clock is valid as long as HSYNC is asserted.

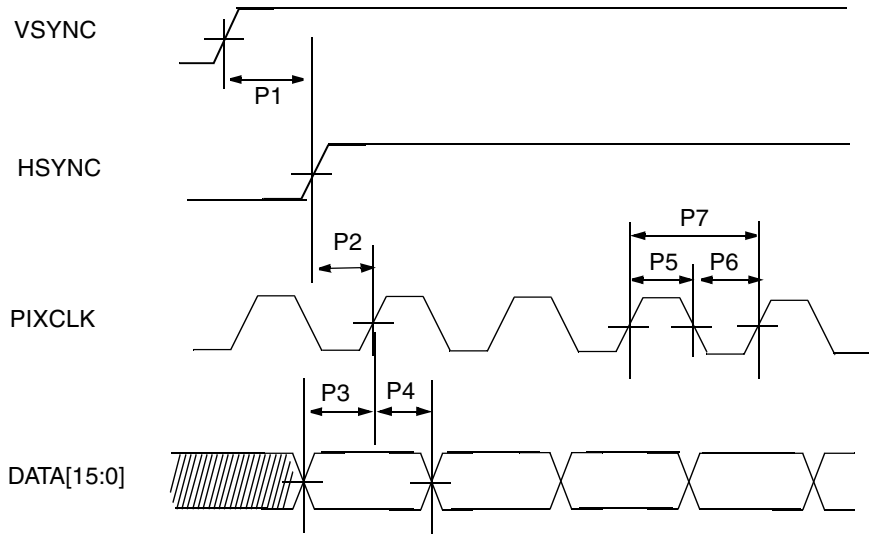

Figure 20. CSI Gated Clock Mode—Sensor Data at Falling Edge, Latch Data at Rising Edge

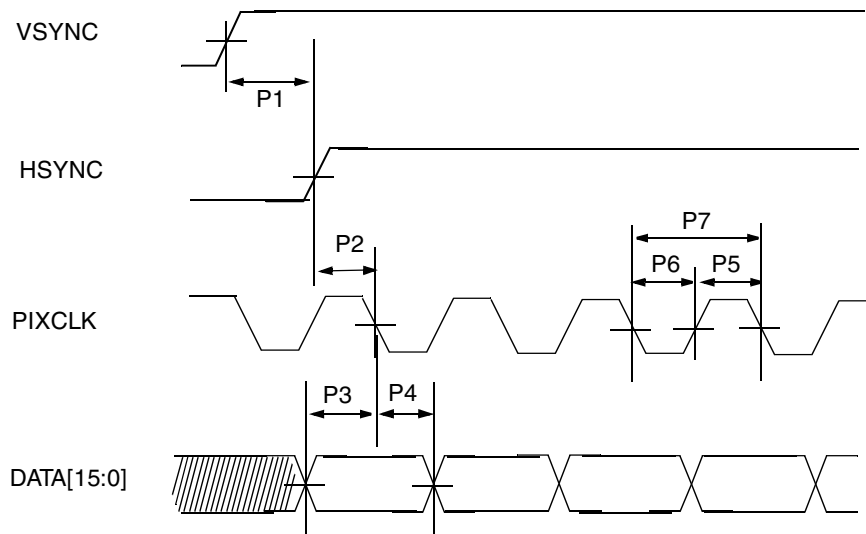

Figure 21. CSI Gated Clock Mode—Sensor Data at Rising Edge, Latch Data at Falling Edge

Table 39. CSI Gated Clock Mode Timing Parameters

ID	Parameter	Symbol	Min.	Max.	Units
P1	CSI VSYNC to HSYNC time	tV2H	67.5	—	ns
P2	CSI HSYNC setup time	tHsu	1	—	ns
P3	CSI DATA setup time	tDsu	1	—	ns
P4	CSI DATA hold time	tDh	1.2	—	ns
P5	CSI pixel clock high time	tCLKh	10	—	ns
P6	CSI pixel clock low time	tCLKl	10	—	ns
P7	CSI pixel clock frequency	fCLK	—	48 ± 10%	MHz

3.7.4.2 Ungated Clock Mode Timing

Figure 22 shows the ungated clock mode timings of CSI, and Table 40 describes the timing parameters (P1–P6) that are shown in the figure. In ungated mode the VSYNC and PIXCLK signals are used, and the HSYNC signal is ignored.

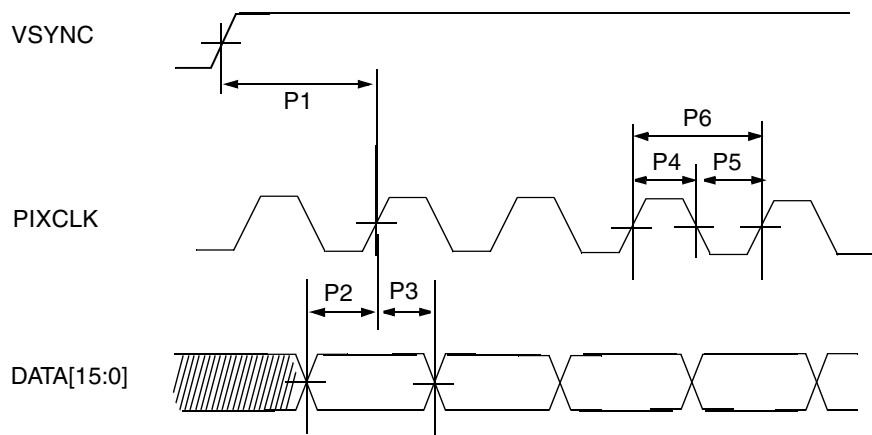

Figure 22. CSI Ungated Clock Mode—Sensor Data at Falling Edge, Latch Data at Rising Edge

Table 40. CSI Ungated Clock Mode Timing Parameters

ID	Parameter	Symbol	Min.	Max.	Units
P1	CSI VSYNC to pixel clock time	tVSYNC	67.5	—	ns
P2	CSI DATA setup time	tDsu	1	—	ns
P3	CSI DATA hold time	tDh	1.2	—	ns
P4	CSI pixel clock high time	tCLKh	10	—	ns
P5	CSI pixel clock low time	tCLKl	10	—	ns
P6	CSI pixel clock frequency	fCLK	—	48 ± 10%	MHz

3.7.5 Configurable Serial Peripheral Interface (CSPI) Timing

Figure 23 and Figure 24 provide CSPI master and slave mode timing diagrams, respectively. Table 41 describes the timing parameters (t_1 – t_{14}) that are shown in the figures. The values shown in timing diagrams were tested using a worst-case core voltage of 1.1 V, slow pad voltage of 2.68 V, and fast pad voltage of 1.65 V.

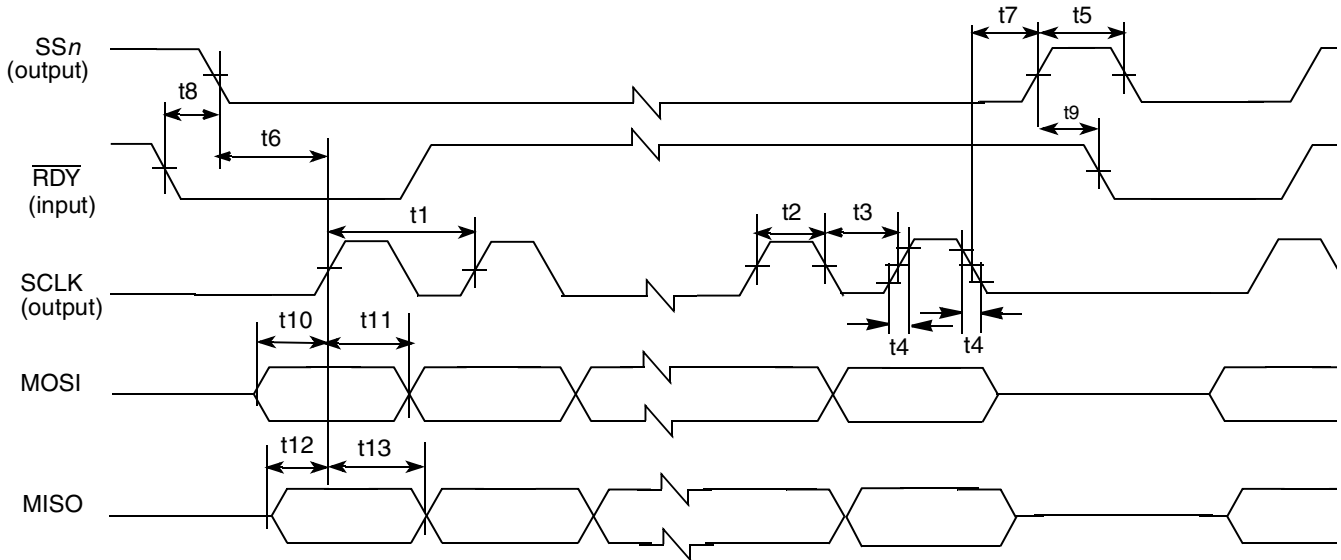

Figure 23. CSPI Master Mode Timing Diagram

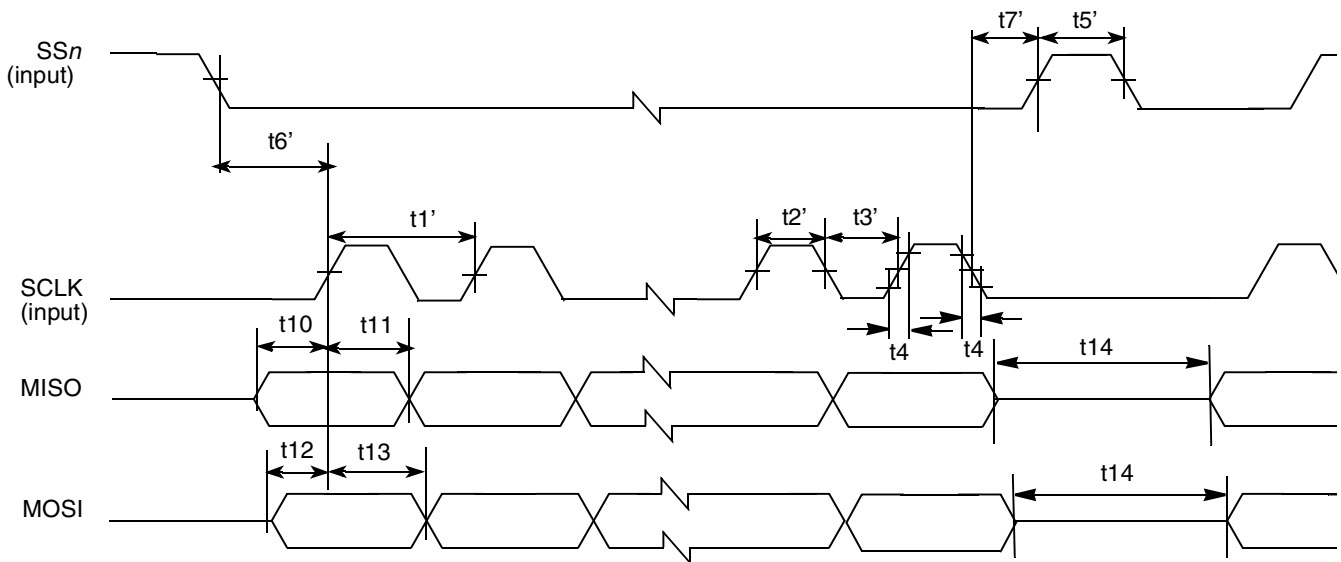

Figure 24. CSPI Slave Mode Timing Diagram

Table 41. CSPI Interface Timing Parameters

ID	Parameter Description	Symbol	Minimum	Maximum	Units
t1	CSPI master SCLK cycle time	t_{clko}	60.2	—	ns
t2	CSPI master SCLK high time	t_{clkoH}	22.65	—	ns
t3	CSPI master SCLK low time	t_{clkoL}	22.47	—	ns
t1'	CSPI slave SCLK cycle time	t_{clki}	60.2	—	ns
t2'	CSPI slave SCLK high time	t_{clkiH}	30.1	—	ns
t3'	CSPI slave SCLK low time	t_{clkiL}	30.1	—	ns
t4	CSPI SCLK transition time	t_{pr}^1	2.6	8.5	ns
t5	SSn output pulse width	t_{WssO}	$2T_{sclk}^2 + T_{wait}^3$	—	—
t5'	SSn input pulse width	t_{Wssi}	T_{per}^4	—	—
t6	SSn output asserted to first SCLK edge (SS output setup time)	t_{Ssso}	$3T_{sclk}$	—	—
t6'	SSn input asserted to first SCLK edge (SS input setup time)	t_{Sssi}	T_{per}	—	—
t7	CSPI master: Last SCLK edge to SSn negated (SS output hold time)	t_{Hsso}	$2T_{sclk}$	—	—
t7'	CSPI slave: Last SCLK edge to SSn negated (SS input hold time)	t_{Hssi}	30	—	ns
t8	CSPI master: CSPI1_RDY low to SSn asserted (CSPI1_RDY setup time)	t_{Srdy}	$2T_{per}$	$5T_{per}$	—
t9	CSPI master: SSn negated to CSPI1_RDY low	t_{Hrdy}	0	—	ns
t10	Output data setup time	t_{Sdatao}	$(t_{clkoL} \text{ or } t_{clkoH} \text{ or } t_{clkiL} \text{ or } t_{clkiH}) - T_{ipg}^5$	—	—
t11	Output data hold time	t_{Hdatao}	$t_{clkoL} \text{ or } t_{clkoH} \text{ or } t_{clkiL} \text{ or } t_{clkiH}$	—	—
t12	Input data setup time	t_{Sdatai}	$T_{ipg} + 0.5$	—	ns
t13	Input data hold time	t_{Hdatai}	0	—	ns
t14	Pause between data word	t_{pause}	0	—	ns

¹ The output SCLK transition time is tested with 25 pF drive.

² T_{sclk} = CSPI clock period

³ T_{wait} = Wait time, as specified in the sample period control register

⁴ T_{per} = CSPI reference baud rate clock period (PERCLK2)

⁵ T_{ipg} = CSPI main clock IPG_CLOCK period

3.7.6 External Memory Interface (EMI) Timing

The EMI module includes the enhanced SDRAM/LPDDR memory controller (ESDCTL), NAND Flash controller (NFC), and wireless external interface module (WEIM). The following subsections give timing information for these submodules.

3.7.6.1 ESDCTL Electrical Specifications

3.7.6.1.1 SDRAM Memory Controller

The following diagrams and tables specify the timings related to the SDRAMC module which interfaces SDRAM.

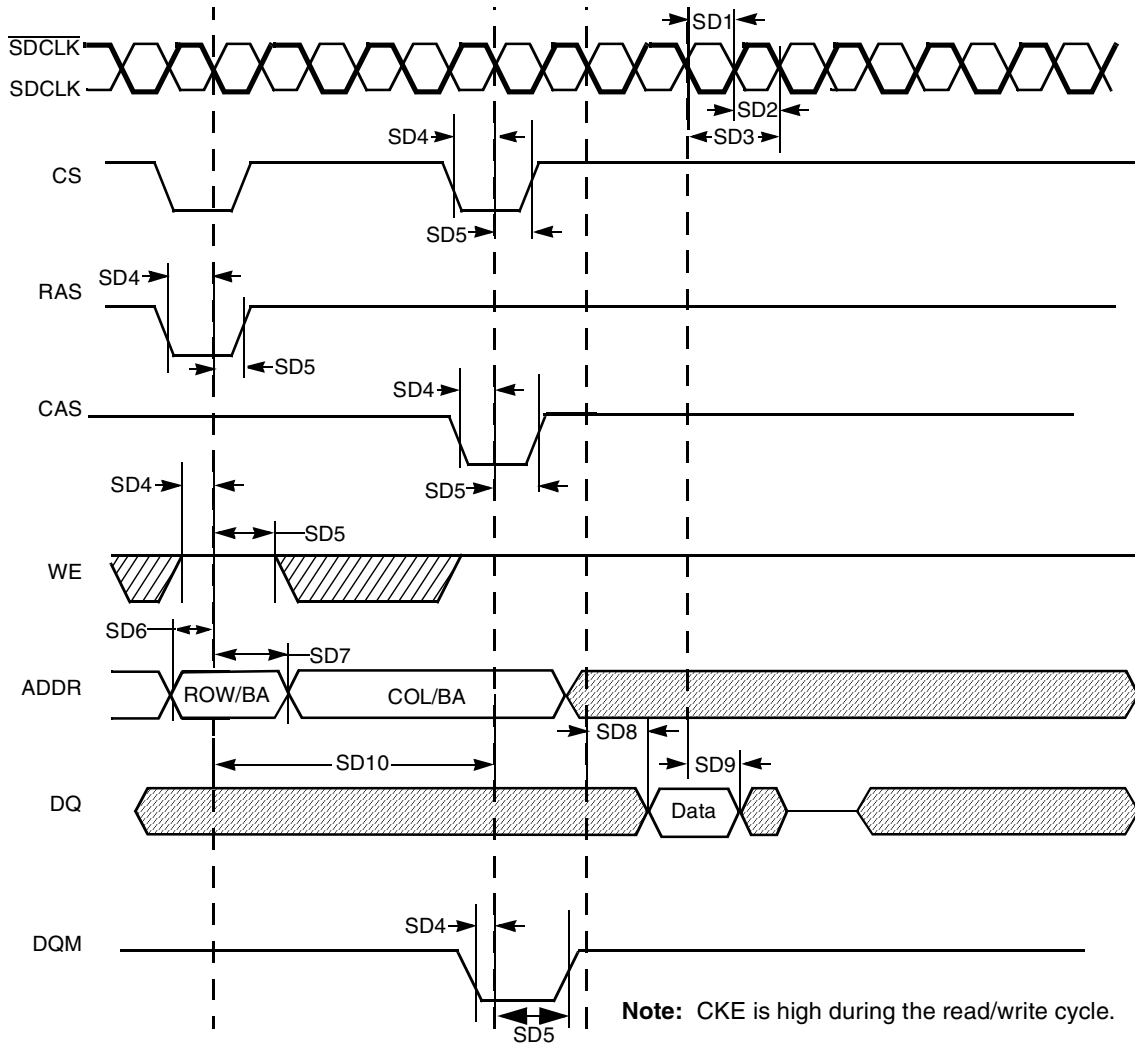

Figure 25. SDRAM Read Cycle Timing Diagram

Table 42. DDR/SDR SDRAM Read Cycle Timing Parameters

ID	Parameter	Symbol	Min.	Max.	Unit
SD1	SDRAM clock high-level width ¹	t _{CH}	3.4	4.1	ns
SD2	SDRAM clock low-level width ¹	t _{CL}	3.4	4.1	ns
SD3	SDRAM clock cycle time	t _{CK}	7.5	—	ns
SD4	CS, RAS, CAS, WE, DQM, CKE setup time	t _{CMS}	2.0	—	ns
SD5	CS, RAS, CAS, WE, DQM, CKE hold time	t _{CMH}	1.8	—	ns

Table 42. DDR/SDR SDRAM Read Cycle Timing Parameters (continued)

ID	Parameter	Symbol	Min.	Max.	Unit
SD6	Address setup time	tAS	2.0	—	ns
SD7	Address hold time	tAH	1.8	—	ns
SD8	SDRAM access time	tAC	—	6.47	ns

Table 42. DDR/SDR SDRAM Read Cycle Timing Parameters (continued)

ID	Parameter	Symbol	Min.	Max.	Unit
SD9	Data out hold time ²	tOH	1.2	—	ns
SD10	Active to read/write command period	tRC	10	—	clock

¹ SD1 + SD2 does not exceed 7.5 ns for 133 MHz.

² Timing parameters are relevant only to SDR SDRAM. For the specific DDR SDRAM data related timing parameters, see [Table 46](#) and [Table 47](#).

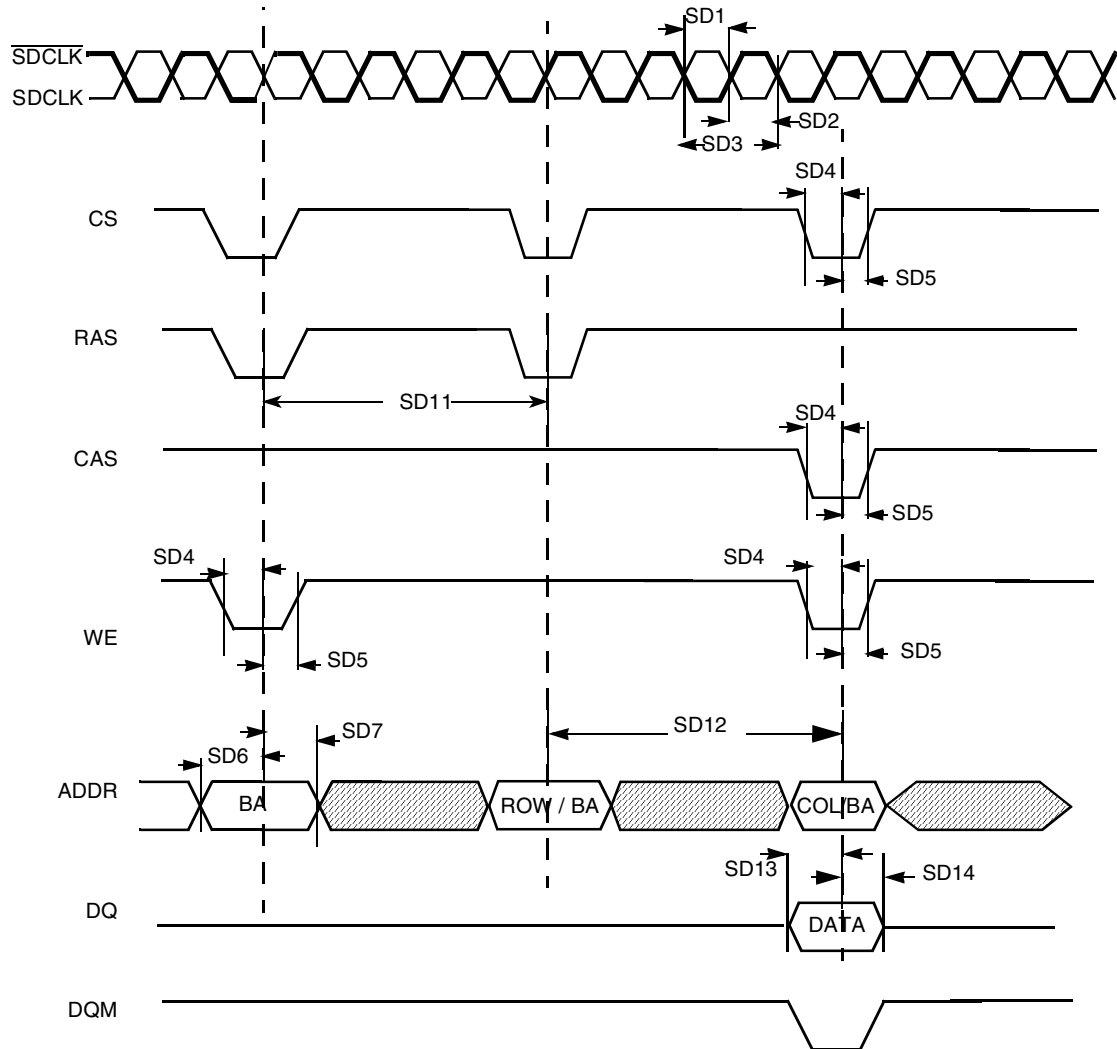

Figure 26. SDR SDRAM Write Cycle Timing Diagram

Table 43. SDR SDRAM Write Timing Parameters

ID	Parameter	Symbol	Min.	Max.	Unit
SD1	SDRAM clock high-level width	tCH	3.4	4.1	ns
SD2	SDRAM clock low-level width	tCL	3.4	4.1	ns
SD3	SDRAM clock cycle time	tCK	7.5	—	ns
SD4	CS, RAS, CAS, WE, DQM, CKE setup time	tCMS	2.0	—	ns
SD5	CS, RAS, CAS, WE, DQM, CKE hold time	tCMH	1.8	—	ns
SD6	Address setup time	tAS	2.0	—	ns
SD7	Address hold time	tAH	1.8	—	ns
SD11	Precharge cycle period ¹	tRP	1	4	clock
SD12	Active to read/write command delay ¹	tRCD	1	8	clock
SD13	Data setup time	tDS	2.0	—	ns
SD14	Data hold time	tDH	1.3	—	ns

¹ SD11 and SD12 are determined by SDRAM controller register settings.

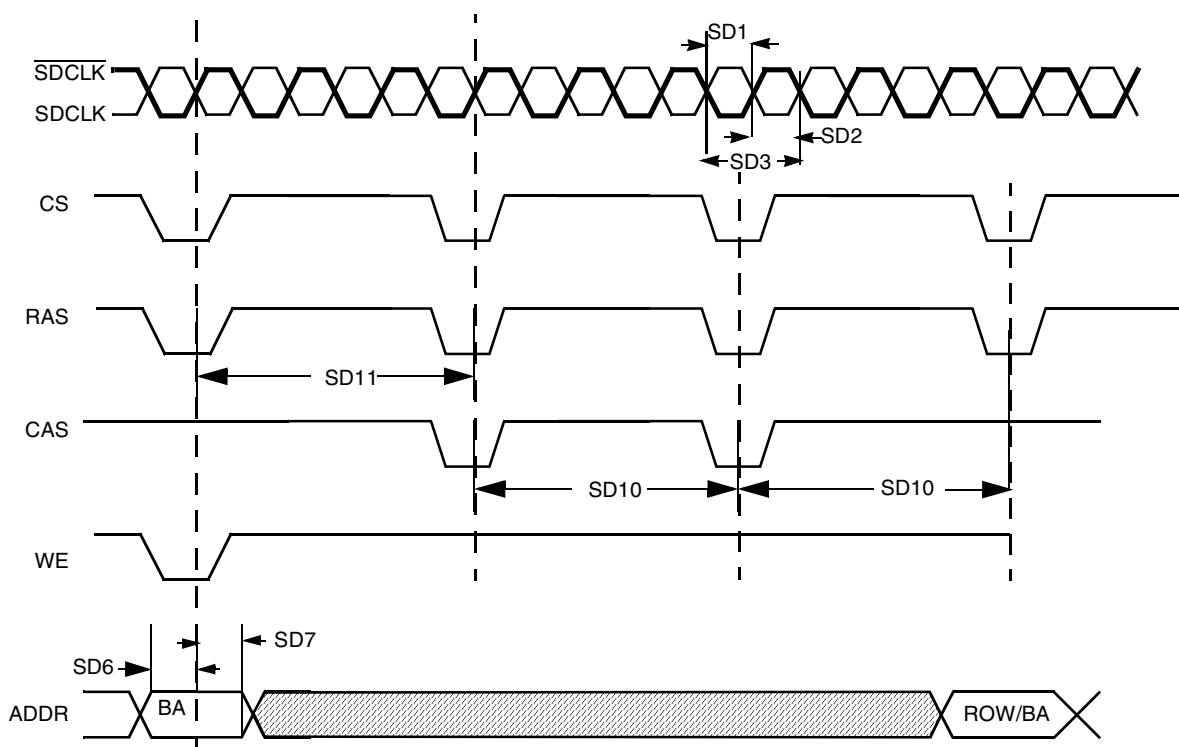

Figure 27. SDRAM Refresh Timing Diagram

Table 44. SDRAM Refresh Timing Parameters

ID	Parameter	Symbol	Min.	Max.	Unit
SD1	SDRAM clock high-level width	tCH	3.4	4.1	ns
SD2	SDRAM clock low-level width	tCL	3.4	4.1	ns
SD3	SDRAM clock cycle time	tCK	7.5	—	ns
SD6	Address setup time	tAS	1.8	—	ns
SD7	Address hold time	tAH	1.8	—	ns
SD10	Precharge cycle period ¹	tRP	1	4	clock
SD11	Auto precharge command period ¹	tRC	2	20	clock

¹ SD10 and SD11 are determined by SDRAM controller register settings.

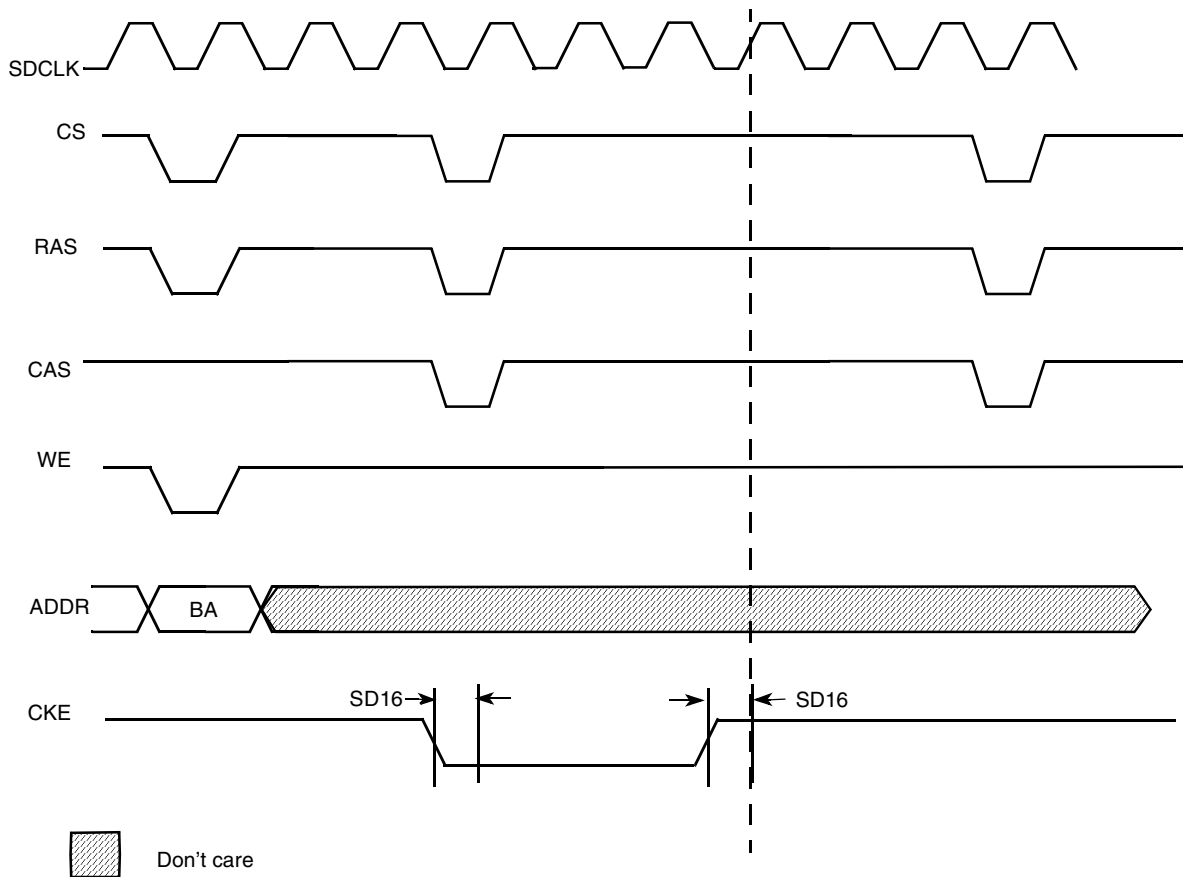

Figure 28. SDRAM Self-Refresh Cycle Timing Diagram

NOTE

The clock continues to run unless CKE is low. Then the clock is stopped in low state.

Table 45. SDRAM Self-Refresh Cycle Timing Parameters

ID	Parameter	Symbol	Min.	Max.	Unit
SD16	CKE output delay time	tCKS	1.8	—	ns

3.7.6.1.2 Mobile DDR SDRAM–Specific Parameters

The following diagrams and tables specify the timings related to the SDRAMC module which interfaces with the mobile DDR SDRAM.

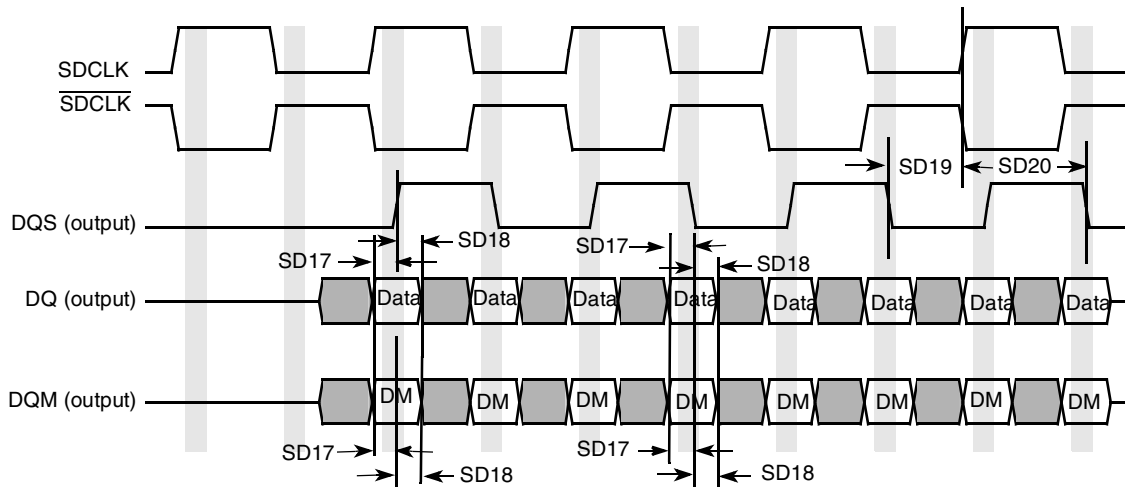

Figure 29. Mobile DDR SDRAM Write Cycle Timing Diagram

Table 46. Mobile DDR SDRAM Write Cycle Timing Parameters¹

ID	Parameter	Symbol	Min.	Max.	Unit
SD17	DQ and DQM setup time to DQS	tDS	0.95	—	ns
SD18	DQ and DQM hold time to DQS	tDH	0.95	—	ns
SD19	Write cycle DQS falling edge to SDCLK output delay time	tDSS	1.8	—	ns
SD20	Write cycle DQS falling edge to SDCLK output hold time	tDSH	1.8	—	ns

¹ Test condition: Measured using delay line 5 programmed as follows: ESDCDLY5[15:0] = 0x0703.

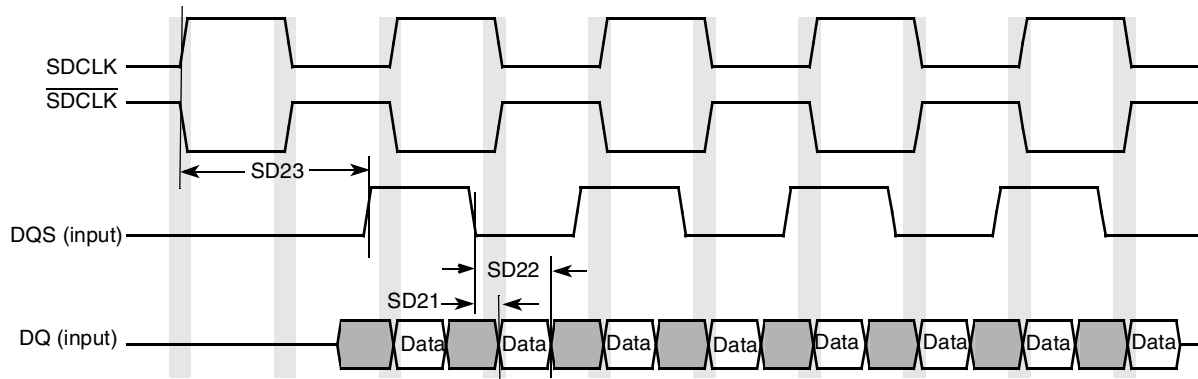

Figure 30. Mobile DDR SDRAM DQ versus DQS and SDCLK Read Cycle Timing Diagram

Table 47. Mobile DDR SDRAM Read Cycle Timing Parameters

ID	Parameter	Symbol	Min.	Max.	Unit
SD21	DQS – DQ Skew (defines the data valid window in read cycles related to DQS)	tDQSQ	—	0.85	ns
SD22	DQS DQ HOLD time from DQS	tQH	2.3	—	ns
SD23	DQS output access time from SDCLK posedge	tDQSCK	—	6.7	ns

3.7.6.1.3 DDR2 SDRAM–Specific Parameters

The following diagrams and tables specify timing related to the SDRAMC module, which interfaces with DDR2 SDRAM.

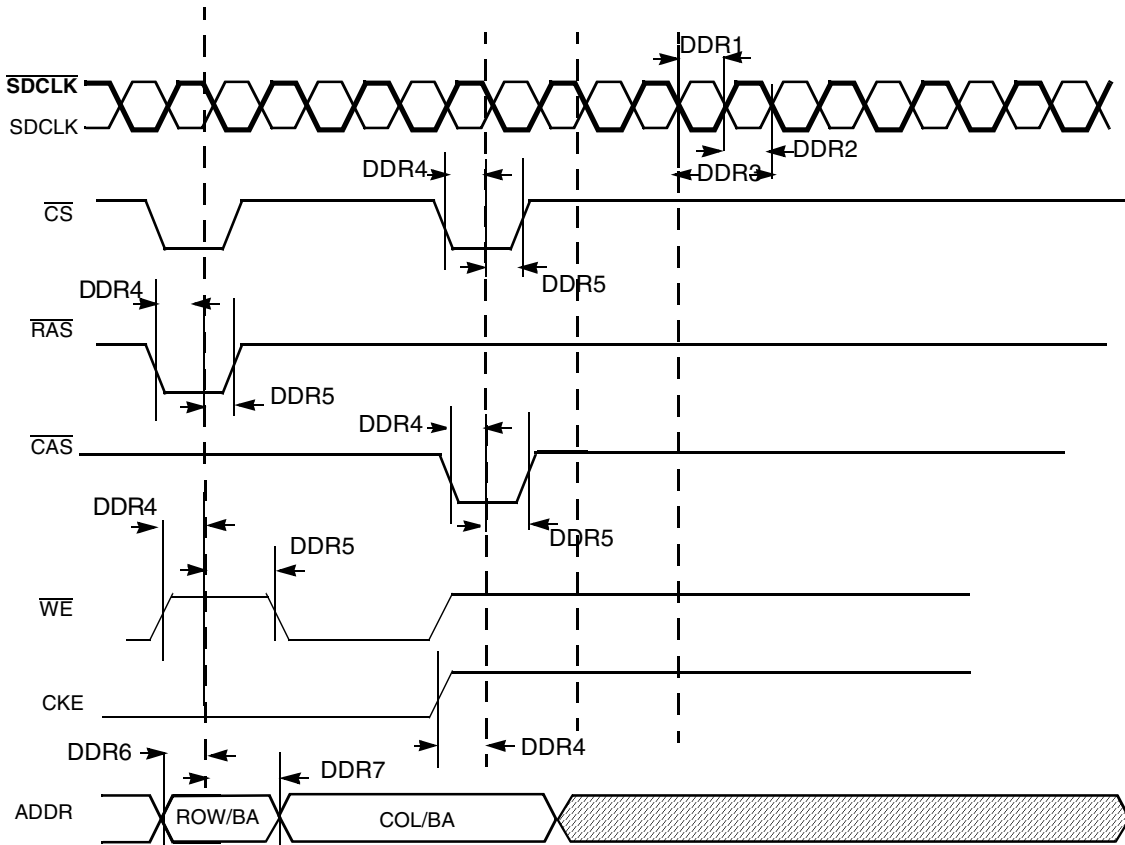

Figure 31. DDR2 SDRAM Basic Timing Parameters

Table 48 provides values for a command/address slew rate of 1 V/ns and an SDCLK, SDCLK_B differential slew rate of 2 V/ns. For additional values, use Table 49, “tIS, tIH Derating Values for DDR2-400, DDR2-533.”

Table 48. DDR2 SDRAM Timing Parameter Table

ID	Parameter	Symbol	DDR2-400		Unit
			Min.	Max.	
DDR1	SDRAM clock high-level width	tCH	0.45	0.55	tck
DDR2	SDRAM clock low-level width	tCL	0.45	0.55	tck
DDR3	SDRAM clock cycle time	tCK	7.5	8	ns

Table 48. DDR2 SDRAM Timing Parameter Table (continued)

ID	Parameter	Symbol	DDR2-400		Unit
			Min.	Max.	
DDR4	CS, RAS, CAS, CKE, WE setup time	tIS	0.35	—	ns
DDR5	CS, RAS, CAS, CKE, WE hold time	tIH	0.475	—	ns
DDR6	Address output setup time	tIS	0.35	—	ns
DDR7	Address output hold time	tIH	0.475	—	ns

Table 48 shows values for a command/address slew rate of 1 V/ns and an SDCLK, SDCLK_B differential slew rate of 2 V/ns. Table 49 shows additional values for DDR2-400 and DDR2-533.

Table 49. tIS, tIH Derating Values for DDR2-400, DDR2-533

Command/ Address Slew Rate (V/Ns)	CK, CK Differential Slew Rate						Units
	2.0 V/ns		1.5 V/ns		1.0 V/ns		
	ΔtIS	ΔtIH	ΔtIS	ΔtIH	ΔtIS	ΔtIH	
4.0	+187	+94	+217	+124	+247	+154	ps
3.5	+179	+89	+209	+119	+239	+149	ps
3.0	+167	+83	+197	+113	+227	+143	ps
2.5	+150	+75	+180	+105	+210	+135	ps
2.0	+125	+45	+155	+75	+185	+105	ps
1.5	+83	+21	+113	+51	+143	+81	ps
1.0	0	0	+30	+30	+60	+60	ps
0.9	-11	-14	+19	+16	+49	+46	ps
0.8	-25	-31	+5	-1	+35	+29	ps
0.7	-43	-54	-13	-24	+17	+6	ps
0.6	-67	-83	-37	-53	-7	-23	ps
0.5	-110	-125	-80	-95	-50	-65	ps
0.4	-175	-188	-145	-158	-115	-128	ps
0.3	-285	-292	-255	-262	-225	-232	ps
0.25	-350	-375	-320	-345	-290	-315	ps
0.2	-525	-500	-495	-470	-465	-440	ps
0.15	-800	-708	-770	-678	-740	-648	ps
0.1	-1450	-1125	-1420	-1095	-1390	-1065	ps

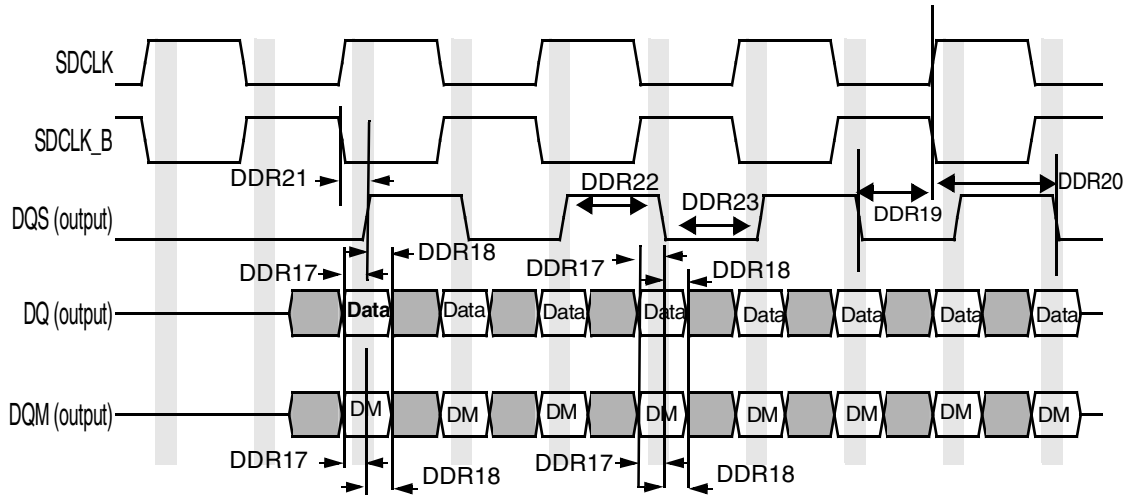

Figure 32. DDR2 SDRAM Write Cycle Timing Diagram

Table 50. DDR2 SDRAM Write Cycle Parameter Table

ID	Parameter	Symbol	DDR2-400		Unit
			Min.	Max.	
DDR17	DQ & DQM setup time to DQS (single-ended strobe) ¹	tDS1(base)	0.025	—	ns
DDR18	DQ & DQM hold time to DQS (single-ended strobe) ¹	tDH1(base)	0.025	—	ns
DDR19	Write cycle DQS falling edge to SDCLK output setup time	tDSS	0.2	—	tCK
DDR20	Write cycle DQS falling edge to SDCLK output hold time	tDSH	0.2	—	tCK
DDR21	DQS latching rising transitions to associated clock edges	tDQSS	-0.25	0.25	tCK
DDR22	DQS high-level width	tDQSH	0.35	—	tCK
DDR23	DQS low-level width	tDQSL	0.35	—	tCK

¹ These values are for a DQ/DM slew rate of 1 V/ns and a DQS slew rate of 1 V/ns. For additional values use Table 51, “DtDS1, DtDH1 Derating Values for DDR2-400, DDR2-533.”

Table 51. ΔtDS1, ΔtDH1 Derating Values for DDR2-400, DDR2-533^{1,2,3}

	DQS Single-Ended Slew Rate																		
	2.0 V/ns		1.5 V/ns		1.0 V/ns		0.9 V/ns		0.8 V/ns		0.7 V/ns		0.6 V/ns		0.5 V/ns		0.4 V/ns		
	ΔtD S1	ΔtD H1	ΔtD S1	ΔtD H1	ΔtD S1	ΔtD H1	ΔtD S1	ΔtD H1	ΔtD S1	ΔtD H1	ΔtD S1	ΔtD H1	ΔtD S1	ΔtD H1	ΔtD S1	ΔtD H1	ΔtD S1	ΔtD H1	

Table 51. Δt_{DS1} , Δt_{DH1} Derating Values for DDR2-400, DDR2-533^{1,2,3} (continued)

		DQS Single-Ended Slew Rate																	
DQ Slew Rate V/ns	2.0	188	188	167	146	125	63	—	—	—	—	—	—	—	—	—	—	—	—
	1.5	146	167	125	125	83	42	81	43	—	—	—	—	—	—	—	—	—	—
	1.0	63	125	42	83	0	0	-2	1	-7	-13	—	—	—	—	—	—	—	—
	0.9	—	—	31	69	-11	-14	-13	-13	-18	-27	-29	-45	—	—	—	—	—	—
	0.8	—	—	—	—	-25	-31	-27	-30	-32	-44	-43	-62	-60	-86	—	—	—	—
	0.7	—	—	—	—	—	—	-45	-53	-50	-67	-61	-85	-78	-109	-108	-152	—	—
	0.6	—	—	—	—	—	—	—	—	-74	-96	-85	-114	-102	-138	-132	-181	-183	-246
	0.5	—	—	—	—	—	—	—	—	—	—	-128	-156	-145	-180	-175	-223	-226	-288
	0.4	—	—	—	—	—	—	—	—	—	—	—	—	-210	-243	-240	-286	-291	-351

¹ All units in 'ps'.

² Test conditions are at capacitance=15pF for DDR PADS. Recommended drive strengths are medium for SDCLK and high for address and controls.

³ SDRAM CLK and DQS related parameters are measured from the 50% point. That is, high is defined as 50% of the signal value, and low is defined as 50% of the signal value. DDR SDRAM CLK parameters are measured at the crossing point of SDCLK and SDCLK (inverted clock).

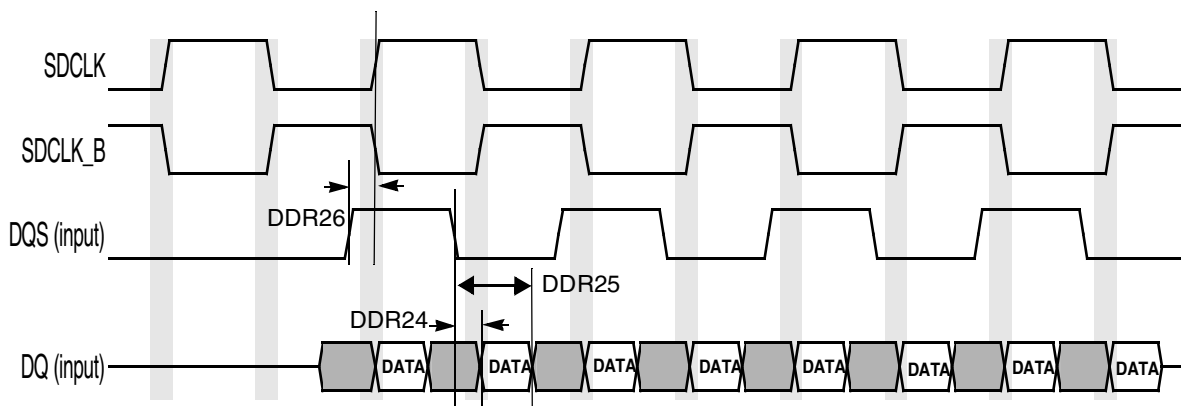

Figure 33. DDR2 SDRAM DQ vs. DQS and SDCLK READ Cycle Timing Diagram

Table 52. DDR2 SDRAM Read Cycle Parameter Table^{1,2}

ID	Parameter	Symbol	DDR2-400		Unit
			Min.	Max.	
DDR24	DQS - DQ Skew (defines the Data valid window in read cycles related to DQS)	tdQSQ	—	0.35	ns
DDR25	DQS DQ in HOLD time from DQS ³	tQH	2.925	—	ns
DDR26	DQS output access time from SDCLK posedge	tdQSK	-0.5	0.5	ns

¹ Test conditions are at capacitance=15 pF for DDR PADS. Recommended drive strengths are medium for SDCLK and high for address and controls.

- ² SDRAM CLK and DQS-related parameters are measured from the 50% point. That is, high is defined as 50% of the signal value, and low is defined as 50% of the signal value. DDR SDRAM CLK parameters are measured at the crossing point of SDCLK and SDCLK (inverted clock).
- ³ The value was calculated for an SDCLK frequency of 133 MHz, by the formula $t_{QH} = t_{HP} - t_{QHS} = \min. (t_{CL}, t_{CH}) - t_{QHS} = 0.45 * t_{CK} - t_{QHS} = 0.45 * 7.5 - 0.45 = 2.925 \text{ ns}$

3.7.6.2 NAND Flash Controller (NFC) Timing

The i.MX25 NFC supports normal timing mode, using two Flash clock cycles for one access of \overline{RE} and \overline{WE} . AC timings are provided as multiplications of the clock cycle and fixed delay. Figure 34 through Figure 37 depicts the relative timing between NFC signals at the module level for different operations under normal mode. Table 53 describes the timing parameters (NF1–NF17) that are shown in the figures.

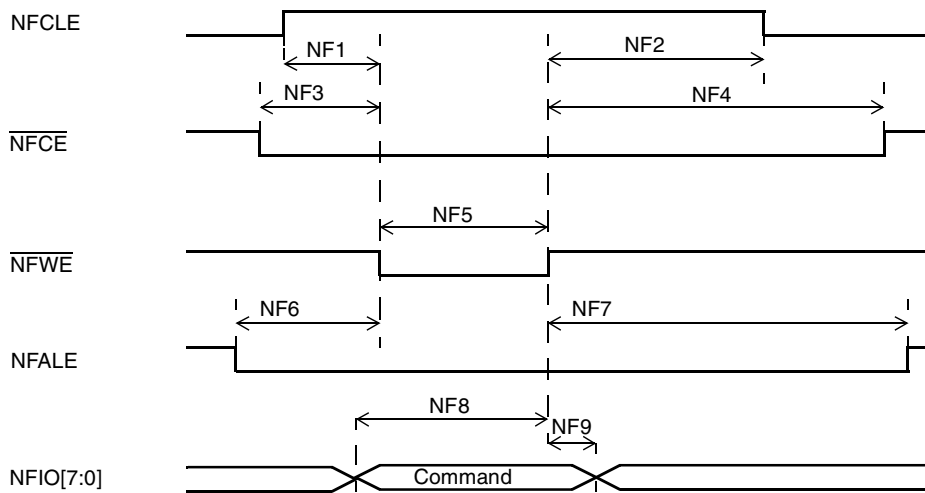

Figure 34. Command Latch Cycle Timing Diagram

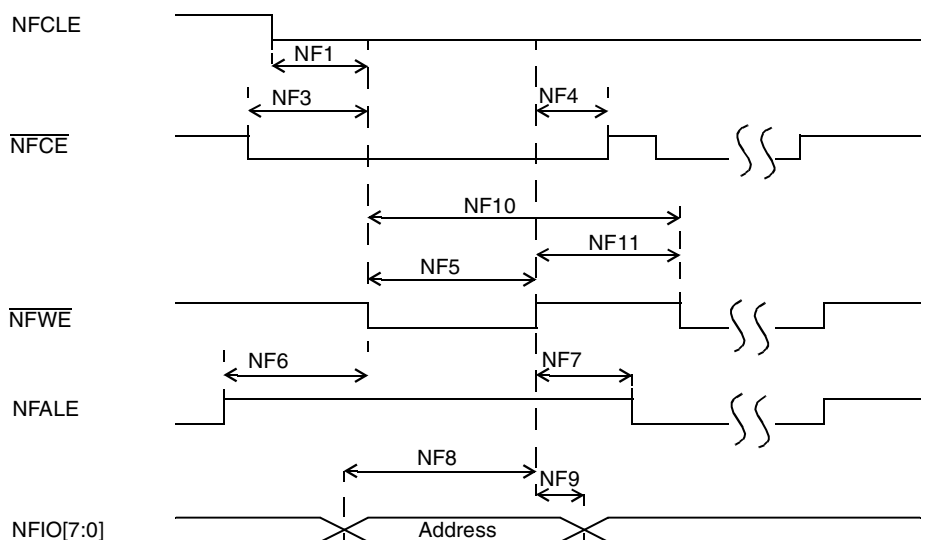

Figure 35. Address Latch Cycle Timing Diagram

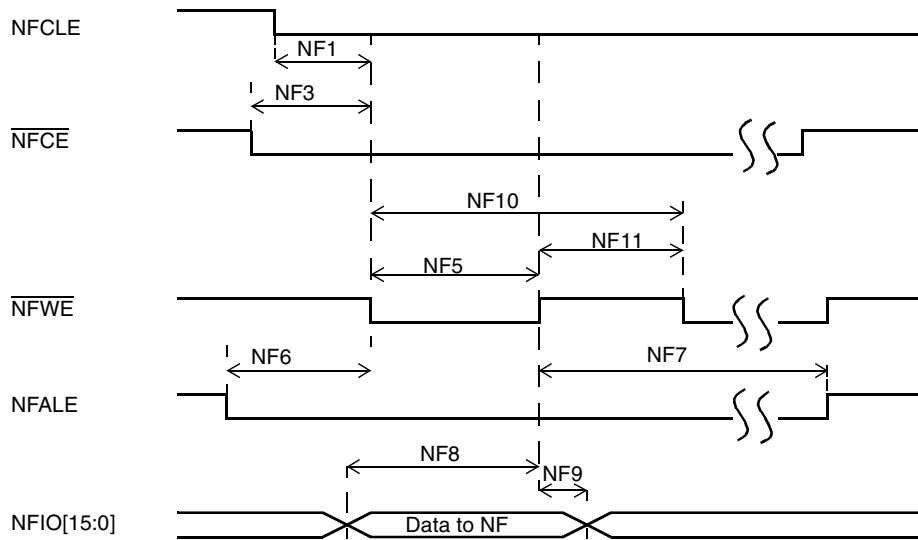

Figure 36. Write Data Latch Cycle Timing Diagram

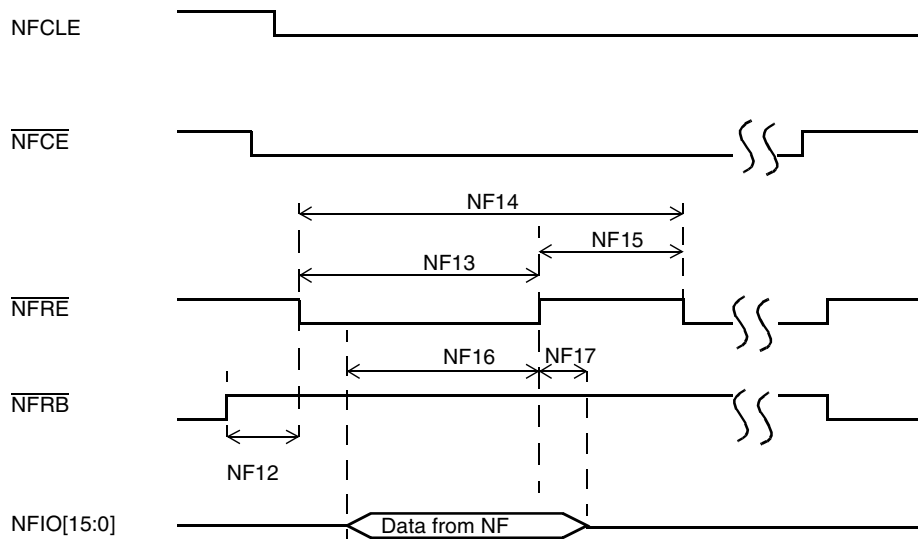

Figure 37. Read Data Latch Cycle Timing Diagram

Table 53. NFC Timing Parameters¹

ID	Parameter	Symbol	Timing T = NFC Clock Cycle		Example Timing for NFC Clock ≈ 33 MHz T = 30 ns		Unit
			Min.	Max.	Min.	Max.	
NF1	NFCLE setup time	tCLS	T-1.0 ns	—	29	—	ns
NF2	NFCLE hold time	tCLH	T-2.0 ns	—	28	—	ns
NF3	$\overline{\text{NFCE}}$ setup time	tCS	2T-5.0 ns	—	55	—	ns
NF4	$\overline{\text{NFCE}}$ hold time	tCH	7T-5.0 ns	—	205	—	ns

Table 53. NFC Timing Parameters¹ (continued)

ID	Parameter	Symbol	Timing T = NFC Clock Cycle		Example Timing for NFC Clock ≈ 33 MHz T = 30 ns		Unit
			Min.	Max.	Min.	Max.	
NF5	$\overline{\text{NF_WP}}$ pulse width	tWP	T–1.5 ns		28.5		ns
NF6	NFALE setup time	tALS	T	—	30	—	ns
NF7	NFALE hold time	tALH	T–3.0 ns	—	27	—	ns
NF8	Data setup time	tDS	2T ns	—	60	—	ns
NF9	Data hold time	tDH	T–5.0 ns	—	25	—	ns
NF10	Write cycle time	tWC	2T		60		ns
NF11	$\overline{\text{NFWE}}$ hold time	tWH	T–2.5 ns		27.5		ns
NF12	Ready to $\overline{\text{NFR}}\overline{\text{E}}$ low	tRR	21T–10 ns	—	620	—	ns
NF13	$\overline{\text{NFR}}\overline{\text{E}}$ pulse width	tRP	1.5T	—	45	—	ns
NF14	READ cycle time	tRC	2T	—	60	—	ns
NF15	$\overline{\text{NFR}}\overline{\text{E}}$ high hold time	tREH	0.5T–2.5 ns		12.5	—	ns
NF16	Data setup on read	tDSR	N/A		10	—	ns
NF17	Data hold on read	tDHR	N/A		0	—	ns

¹ The Flash clock maximum frequency is 50 MHz.

NOTE

For timing purposes, transition to signal high is defined as 80% of signal value; while signal low is defined as 20% of signal value.

Timing for HCLK is 133 MHz. The internal NFC clock (Flash clock) is approximately 33 MHz (30 ns). All timings are listed according to this NFC clock frequency (multiples of NFC clock phases), except NF16 and NF17, which are not related to the NFC clock.

3.7.6.3 Wireless External Interface Module (WEIM) Timing

Figure 38 depicts the timing of the WEIM module, and Table 54 describes the timing parameters (WE1–WE27) shown in the figure.

All WEIM output control signals may be asserted and negated by internal clock relative to BCLK rising edge or falling edge according to corresponding assertion/negation control fields. Address always begins relative to BCLK falling edge, but may be ended on rising or falling edge in muxed mode according to the control register configuration. Output data begins relative to BCLK rising edge except in muxed mode, where rising or falling edge may be used according to the control register configuration. Input data, $\overline{\text{ECB}}$ and $\overline{\text{DTACK}}$ are all captured relative to BCLK rising edge.

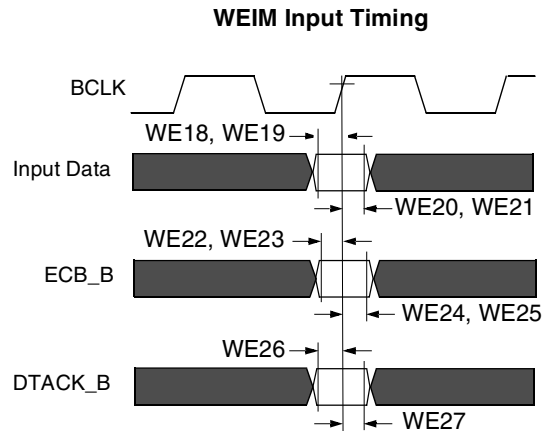
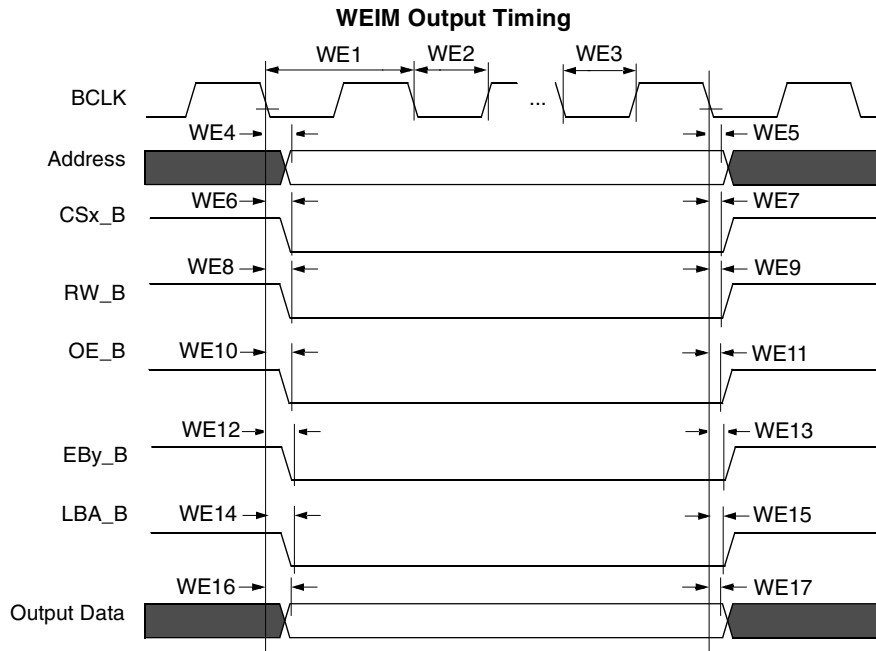

Figure 38. WEIM Bus Timing Diagram

Table 54. WEIM Bus Timing Parameters¹

ID	Parameter	Min.	Max.	Unit
WE1	BCLK cycle time ²	14.5	—	ns
WE2	BCLK low-level width ²	7	—	ns
WE3	BCLK high-level width ²	7	—	ns
WE4	Clock fall to address valid	15	21	ns
WE5	Clock rise/fall to address invalid	22	25	ns
WE6	Clock rise/fall to CSx_B valid	15	19	ns
WE7	Clock rise/fall to CSx_B invalid	3.3	5	ns

Table 54. WEIM Bus Timing Parameters¹ (continued)

ID	Parameter	Min.	Max.	Unit
WE8	Clock rise/fall to RW_B valid	8	12	ns
WE9	Clock rise/fall to RW_B invalid	3	8	ns
WE10	Clock rise/fall to OE_B valid	7	12	ns
WE11	Clock rise/fall to OE_B invalid	3.6	5.5	ns
WE12	Clock rise/fall to EBy_B valid	6	11.5	ns
WE13	Clock rise/fall to EBy_B invalid	6	10	ns
WE14	Clock rise/fall to LBA_B valid	17.5	20	ns
WE15	Clock rise/fall to LBA_B invalid	0	1	ns
WE16	Clock rise/fall to output data valid	5	10	ns
WE17	Clock rise to output data invalid	0	2.5	ns
WE18	Input data valid to clock rise, FCE=1	1	—	ns
WE19	Input Data Valid to Clock rise, FCE=0 (in the case there is ECB_B asserted during access)	(BCLK/2) + 2.63	—	ns
	Input Data Valid to Clock rise, FCE=0 (in the case there is NO ECB_B asserted during access)	6.9	—	ns
WE20	Clock rise to input data invalid, FCE=1	1	—	ns
WE21	Clock rise to input data invalid, FCE=0	2.4	—	ns
WE22	ECB_B setup time, FCE=1	5	—	ns
WE23	ECB_B setup time, FCE=0	7.2	—	ns
WE24	ECB_B hold time, FCE=1	5	—	ns
WE25	ECB_B hold time, FCE=0	0	—	ns
WE26	DTACK_B setup time	5.4	—	ns
WE27	DTACK_B hold time	-3.2	—	ns

¹ High is defined as 80% of signal value; low is defined as 20% of signal value.

² BCLK parameters are being measured from the 50% point. For example, high is defined as 50% of signal value and low is defined as 50% as signal value.

NOTE

The test condition load capacitance was 25 pF. Recommended drive strength for all controls, address, and BCLK is maximum drive.

Recommended drive strength for all controls, address and BCLK is maximum drive.

Figure 39 through Figure 44 give examples of basic WEIM accesses to external memory devices with the timing parameters described in Table 54 for specific control parameter settings.

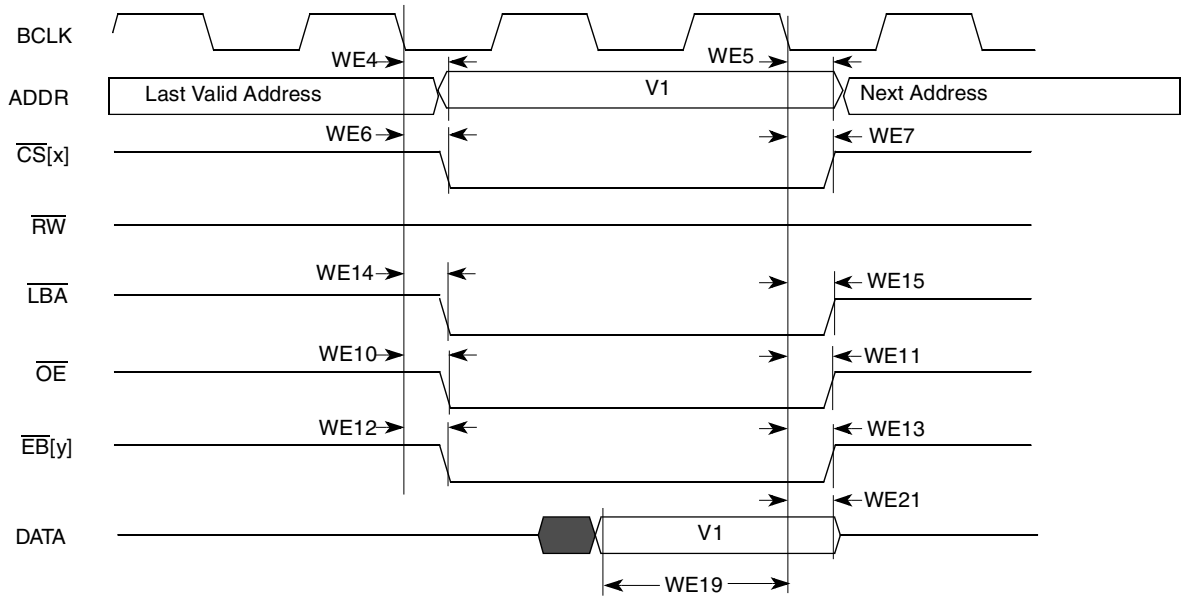

Figure 39. Synchronous Memory Timing Diagram for Read Access—WSC=1

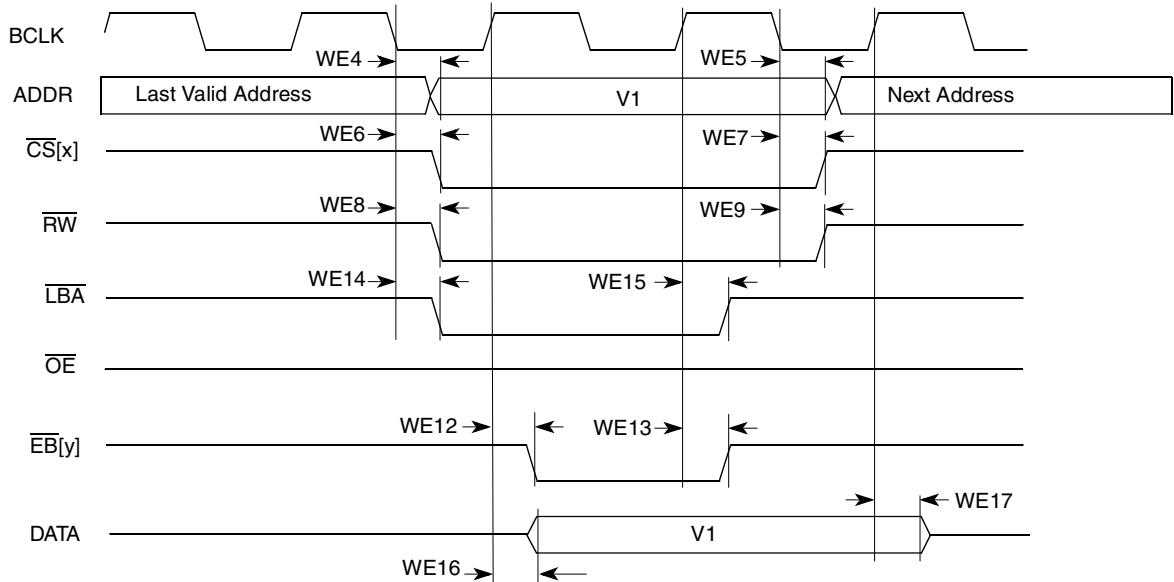
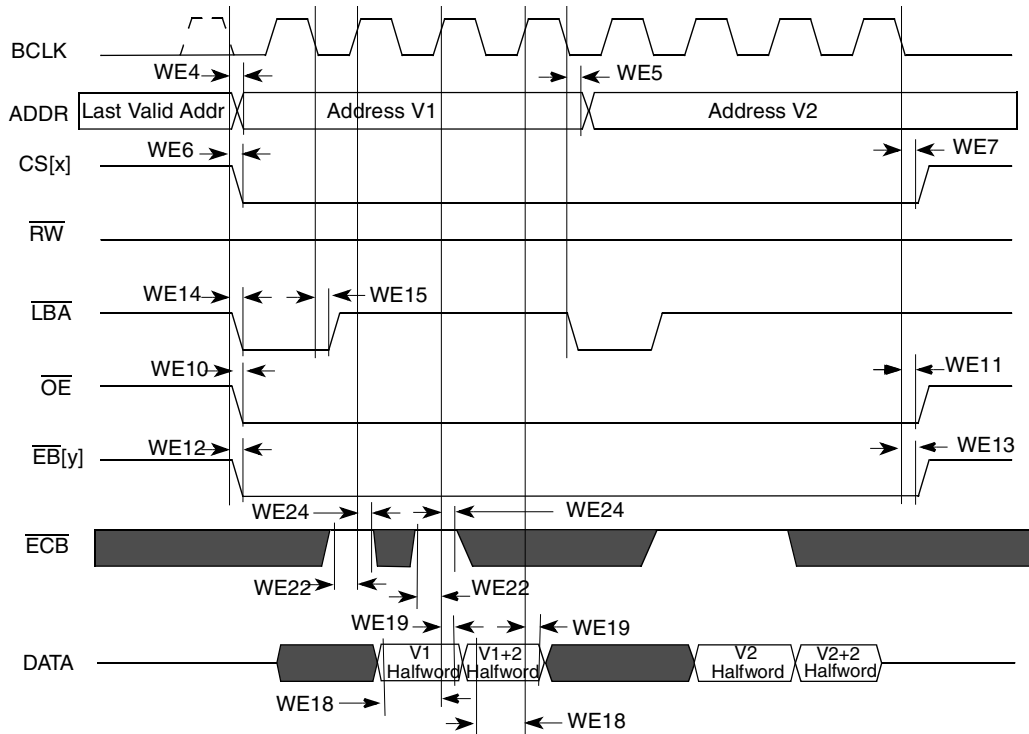
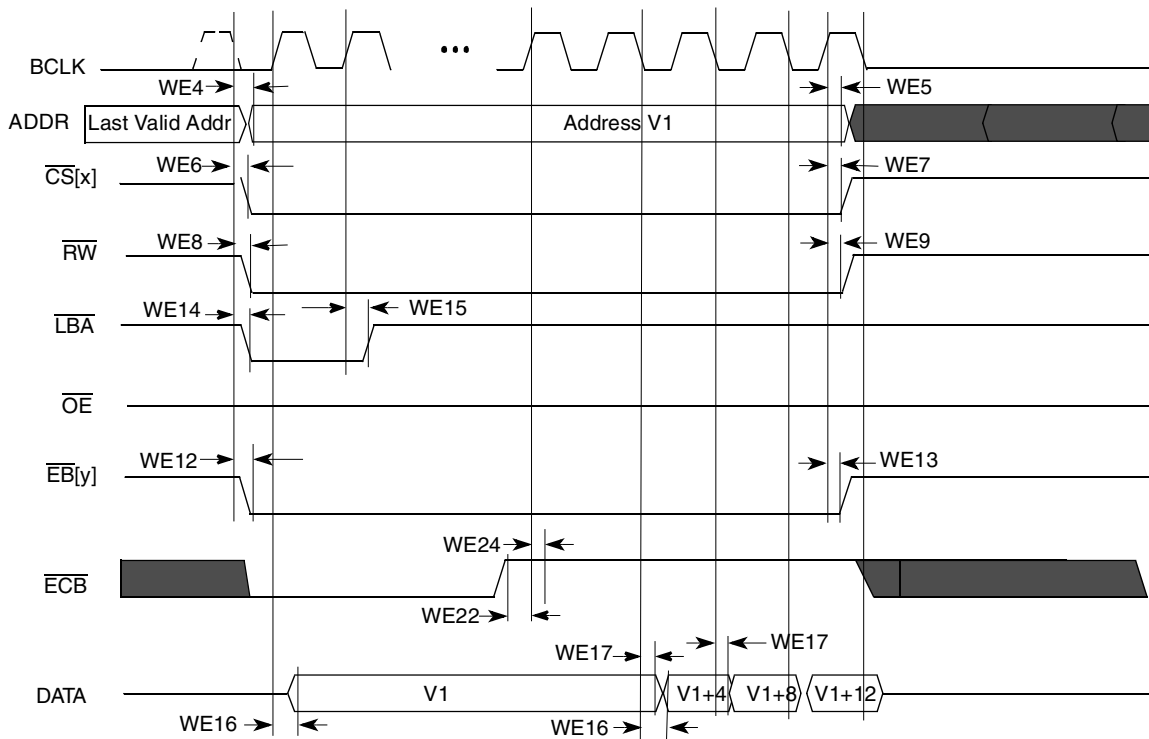

Figure 40. Synchronous Memory Timing Diagram for Write Access—WSC=1, EBWA=1, EBWN=1, LBN=1



**Figure 41. Synchronous Memory Timing Diagram for Two Non-Sequential Read Accesses—
WSC=2, SYNC=1, DOL=0**



**Figure 42. Synchronous Memory Timing Diagram for Burst Write Access—
BCS=1, WSC=4, SYNC=1, DOL=0, PSR=1**

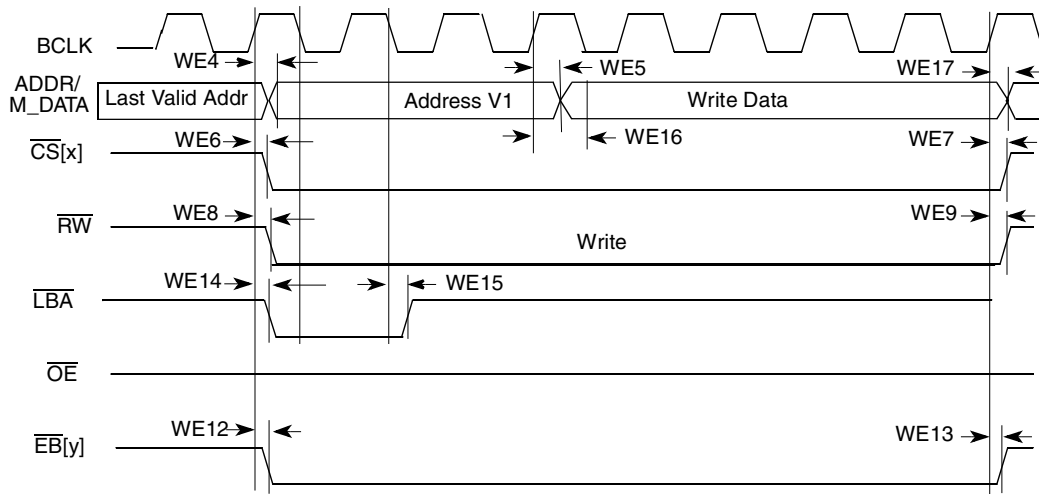

**Figure 43. Muxed A/D Mode Timing Diagram for Synchronous Write Access—
WSC=7, LBA=1, LBN=1, LAH=1**

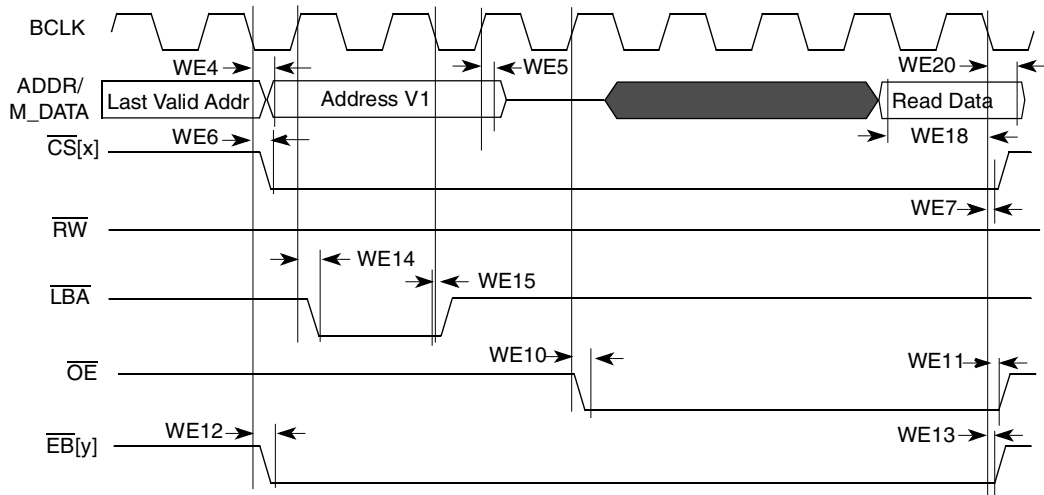

**Figure 44. Muxed A/D Mode Timing Diagram for Synchronous Read Access—
WSC=7, LBA=1, LBN=1, LAH=1, OEA=7**

Figure 45 through Figure 49, and Table 55 help to determine timing parameters relative to chip select (CS) state for asynchronous and DTACK WEIM accesses with corresponding WEIM bit fields and the timing parameters mentioned above.

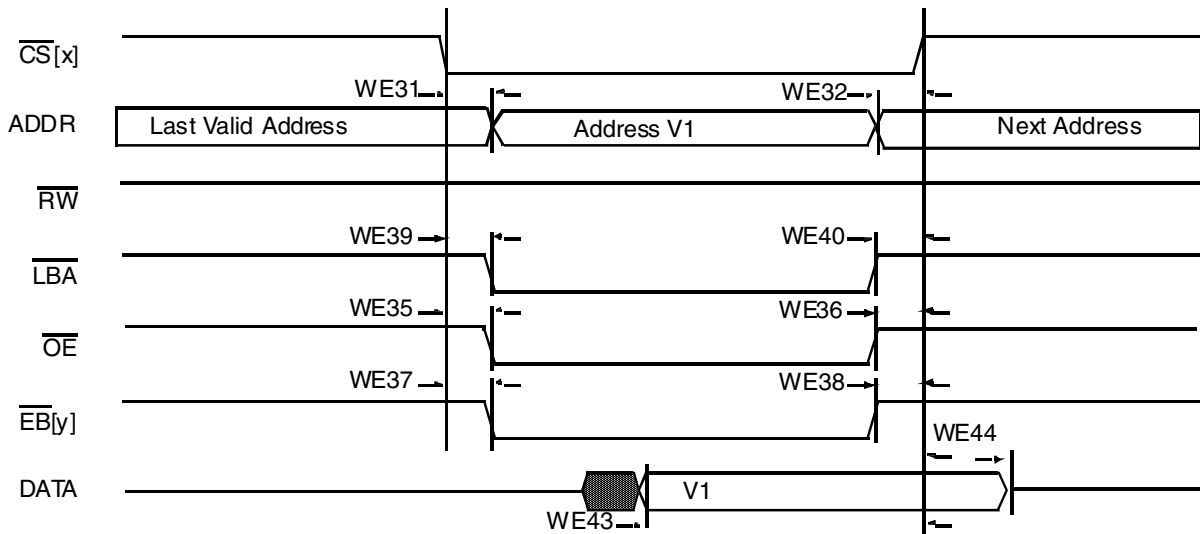

Figure 45. Asynchronous Memory Read Access

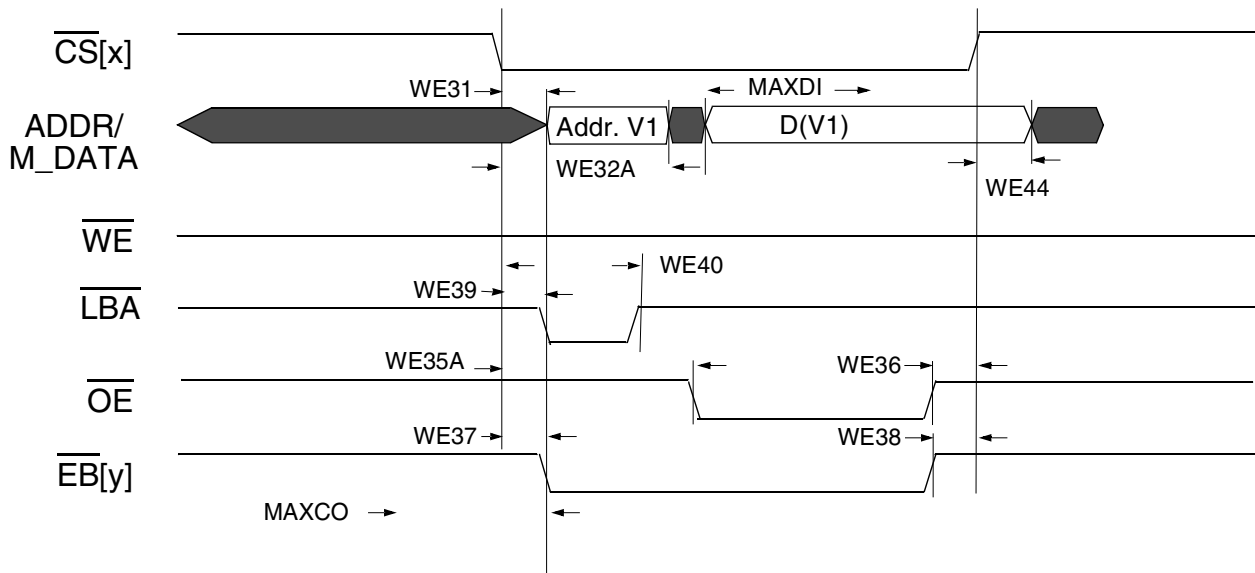

Figure 46. Asynchronous A/D Muxed Read Access (RWSC = 5)

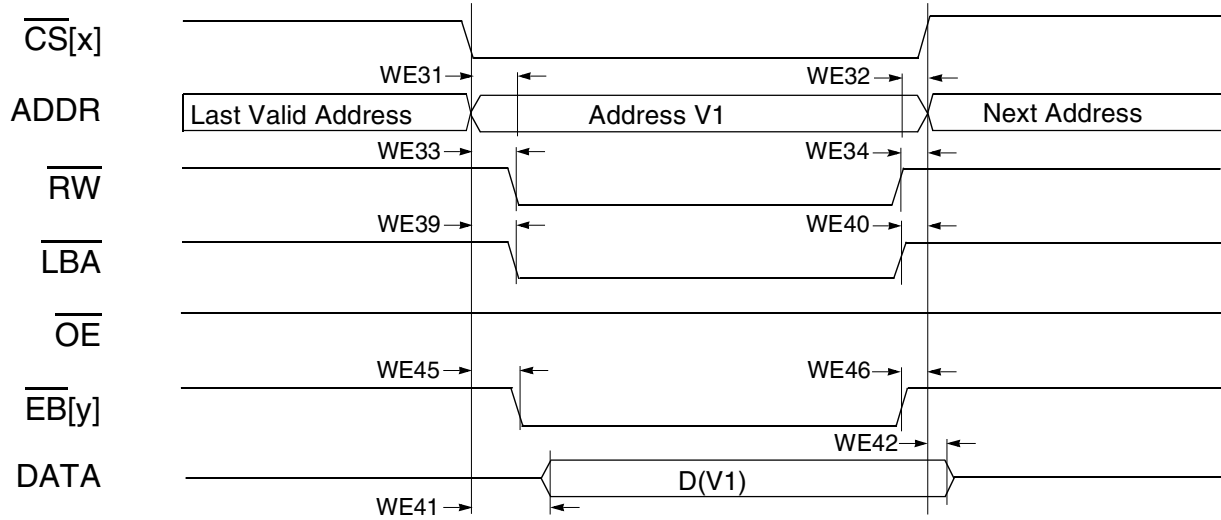

Figure 47. Asynchronous Memory Write Access

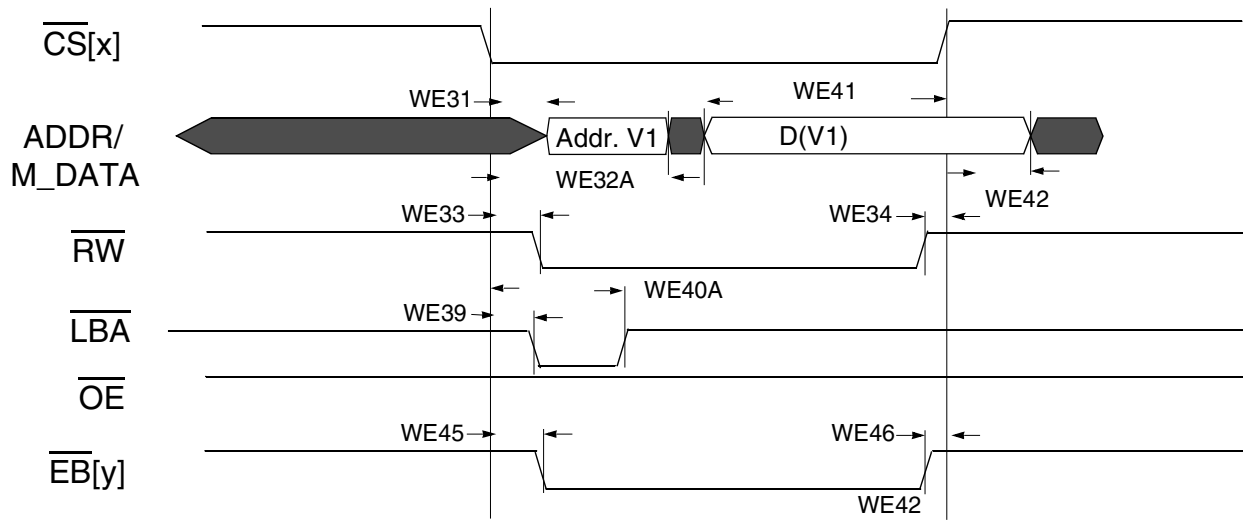

Figure 48. Asynchronous A/D Mux Write Access

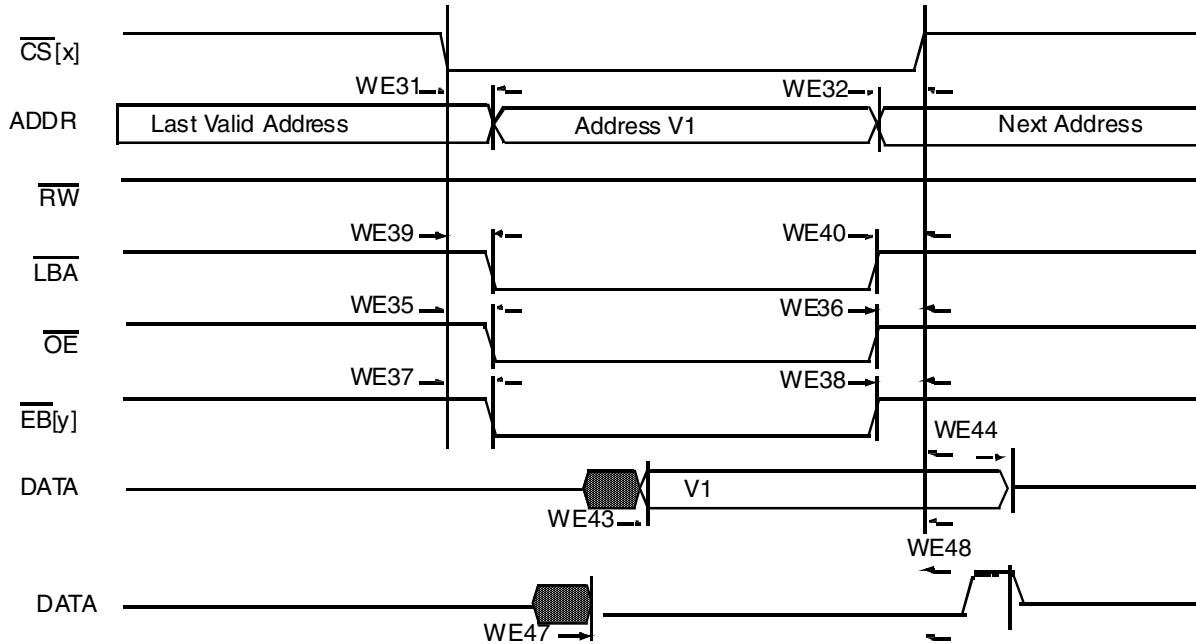

Figure 49. DTACK Read Access

Table 55. WEIM Asynchronous Timing Parameters Relative to Chip Select Table

Ref No.	Parameter	Determination By Synchronous Measured Parameters ¹	Min	Max (If 133 MHz is supported by SoC)	Unit
WE31	$\overline{CS}[x]$ valid to Address Valid	$WE4 - WE6 - CSA^2$	—	$3 - CSA$	ns
WE32	Address Invalid to $\overline{CS}[x]$ invalid	$WE7 - WE5 - CSN^3$	—	$3 - CSN$	ns
WE32A (muxed A/D)	$\overline{CS}[x]$ valid to Address Invalid	$WE4 - WE7 + (LBN + LBA + 1 - CSA^2)$	$-3 + (LBN + LBA + 1 - CSA)$	—	ns
WE33	$\overline{CS}[x]$ Valid to \overline{WE} Valid	$WE8 - WE6 + (WEA - CSA)$	—	$3 + (WEA - CSA)$	ns
WE34	\overline{WE} Invalid to $\overline{CS}[x]$ Invalid	$WE7 - WE9 + (WEN - CSN)$	—	$3 - (WEN_CSN)$	ns
WE35	$\overline{CS}[x]$ Valid to \overline{OE} Valid	$WE10 - WE6 + (OEA - CSA)$	—	$3 + (OEA - CSA)$	ns
WE35A (muxed A/D)	$\overline{CS}[x]$ Valid to \overline{OE} Valid	$WE10 - WE6 + (OEA + RLBN + RLBA + ADH + 1 - CSA)$	$-3 + (OEA + RLBN + RLBA + ADH + 1 - CSA)$	$3 + (OEA + RLBN + RLBA + ADH + 1 - CSA)$	ns
WE36	\overline{OE} Invalid to $\overline{CS}[x]$ Invalid	$WE7 - WE11 + (OEN - CSN)$	—	$3 - (OEN - CSN)$	ns
WE37	$\overline{CS}[x]$ Valid to $\overline{EB}[y]$ Valid (Read access)	$WE12 - WE6 + (RBEA - CSA)$	—	$3 + (RBEA^4 - CSA)$	ns
WE38	$\overline{EB}[y]$ Invalid to $\overline{CS}[x]$ Invalid (Read access)	$WE7 - WE13 + (RBEN - CSN)$	—	$3 - (RBEN^5 - CSN)$	ns
WE39	$\overline{CS}[x]$ Valid to \overline{LBA} Valid	$WE14 - WE6 + (LBA - CSA)$	—	$3 + (LBA - CSA)$	ns
WE40	\overline{LBA} Invalid to $\overline{CS}[x]$ Invalid	$WE7 - WE15 - CSN$	—	$3 - CSN$	ns

Table 55. WEIM Asynchronous Timing Parameters Relative to Chip Select Table (continued)

Ref No.	Parameter	Determination By Synchronous Measured Parameters ¹	Min	Max (If 133 MHz is supported by SoC)	Unit
WE40A (muxed A/D)	$\overline{CS}[x]$ Valid to \overline{LBA} Invalid	$WE14 - WE6 + (LBN + LBA + 1 - CSA)$	$-3 + (LBN + LBA + 1 - CSA)$	$3 + (LBN + LBA + 1 - CSA)$	ns
WE41	$\overline{CS}[x]$ Valid to Output Data Valid	$WE16 - WE6 - WCSA$	—	$3 - WCSA$	ns
WE41A (muxed A/D)	$\overline{CS}[x]$ Valid to Output Data Valid	$WE16 - WE6 + (WLBN + WLBA + ADH + 1 - WCSA)$	—	$3 + (WLBN + WLBA + ADH + 1 - WCSA)$	ns
WE42	Output Data Invalid to $\overline{CS}[x]$ Invalid	$WE17 - WE7 - CSN$	—	$3 - CSN$	ns
WE43	Input Data Valid to $\overline{CS}[x]$ Invalid	$MAXCO - MAXCSO + MAXDI$	$MAXCO^6 - MAXCSO^7 + MAXDI^8$	—	ns
WE44	$\overline{CS}[x]$ Invalid to Input Data invalid	0	0	—	ns
WE45	$\overline{CS}[x]$ Valid to $\overline{EB}[y]$ Valid (Write access)	$WE12 - WE6 + (WBEA - CSA)$	—	$3 + (WBEA - CSA)$	ns
WE46	$\overline{EB}[y]$ Invalid to $\overline{CS}[x]$ Invalid (Write access)	$WE7 - WE13 + (WBEN - CSN)$	—	$-3 + (WBEN - CSN)$	ns
WE47	\overline{DTACK} Valid to $\overline{CS}[x]$ Invalid	$MAXCO - MAXCSO + MAXDTI$	$MAXCO^6 - MAXCSO^7$ ^{Note: Not e:} $+ MAXDTI^9$	—	ns
WE48	$\overline{CS}[x]$ Invalid to \overline{DTACK} invalid	0	0	—	ns

¹ For the value of parameters WE4–WE21, see column BCD = 0 in Table 54.

² \overline{CS} Assertion. This bit field determines when the \overline{CS} signal is asserted during read/write cycles.

³ \overline{CS} Negation. This bit field determines when the \overline{CS} signal is negated during read/write cycles.

⁴ \overline{BE} Assertion. This bit field determines when the \overline{BE} signal is asserted during read cycles.

⁵ \overline{BE} Negation. This bit field determines when the \overline{BE} signal is negated during read cycles.

⁶ Output maximum delay from internal driving ADDR/control FFs to chip outputs.

⁷ Output maximum delay from $\overline{CS}[x]$ internal driving FFs to $\overline{CS}[x]$ out.

⁸ DATA maximum delay from chip input data to its internal FF.

⁹ DTACK maximum delay from chip dtack input to its internal FF.

Note: All configuration parameters (CSA,CSN,WBEA,WBEN,LBA,LBN,OEN,OEA,RBEA & RBEN) are in cycle units.

3.7.7 Enhanced Serial Audio Interface (ESAI) Timing

This section describes general timing requirements for ESAI, as well as the ESAI transmit and receive timing.

Figure 50 shows the ESAI transmit timing diagram.

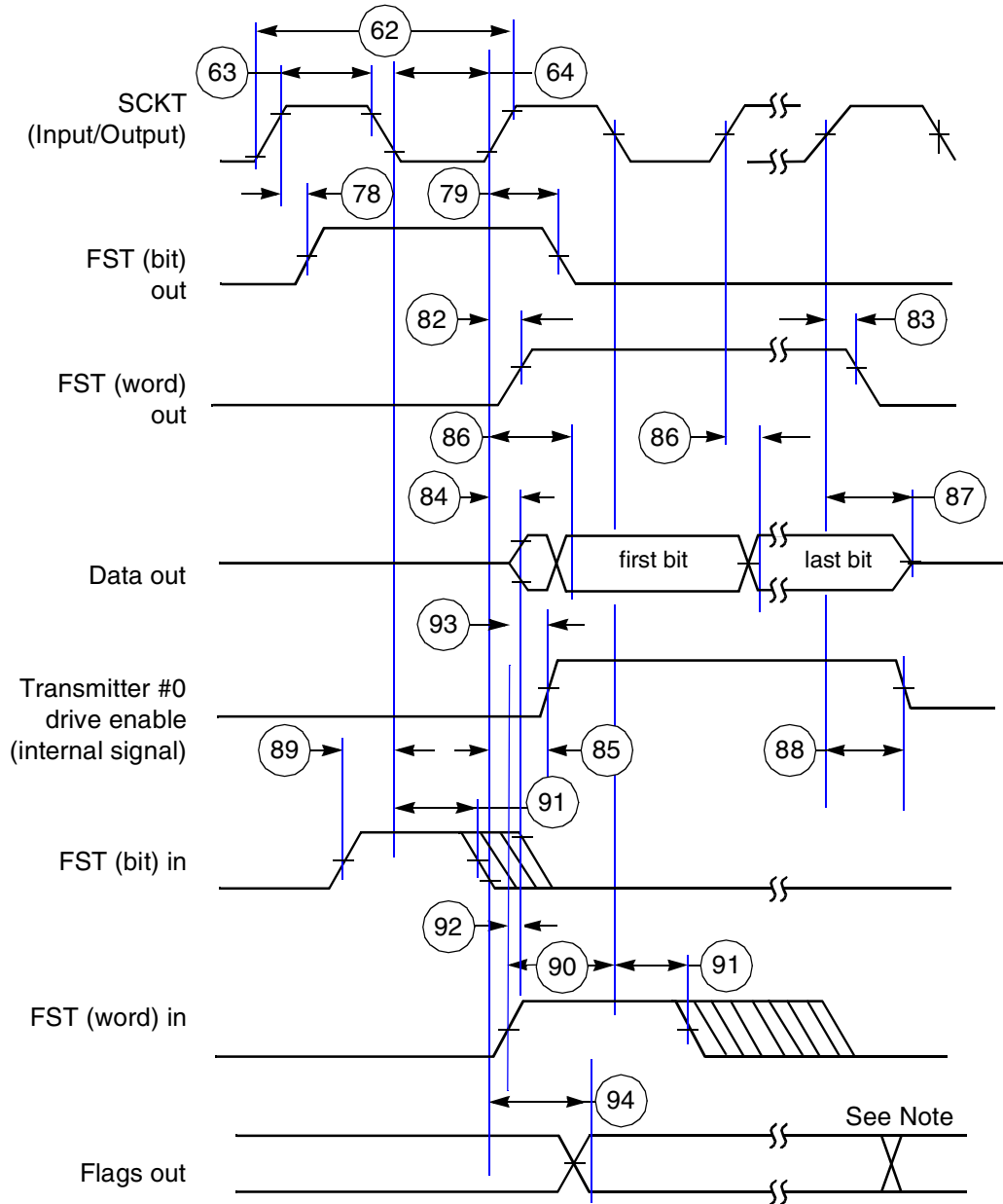

Note: In network mode, output flag transitions can occur at the start of each time slot within the frame. In normal mode, the output flag state is asserted for the entire frame period.

Figure 50. ESAI Transmit Timing

Figure 51 shows the ESAI receive timing diagram.

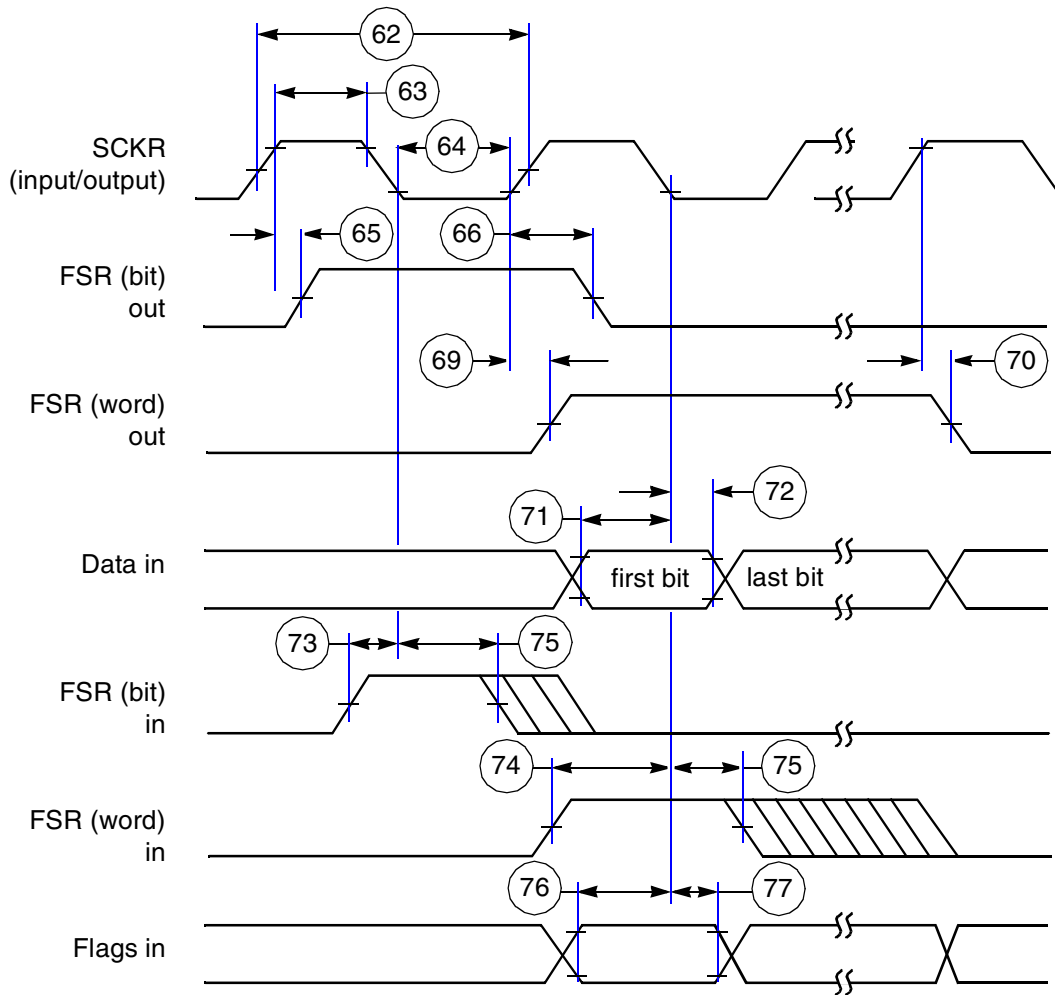

Figure 51. ESAI Receive Timing Diagram

Figure 52 shows the ESAI HCKT timing diagram.

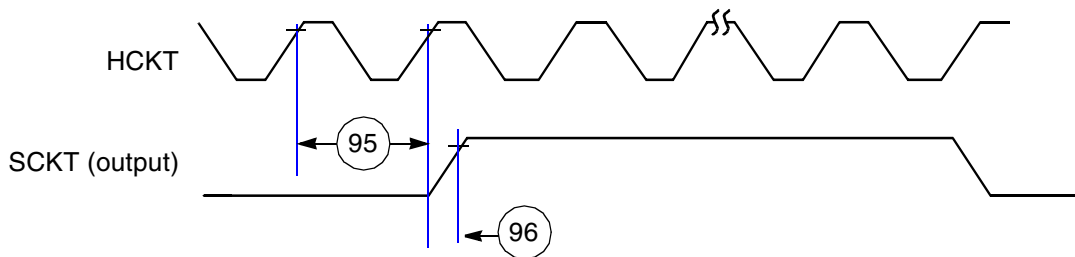

Figure 52. ESAI HCKT Timing

Figure 53 shows the ESAI HCKR timing diagram.

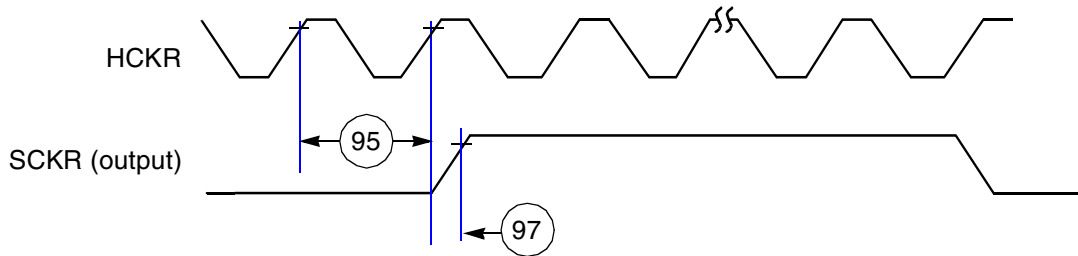

Figure 53. ESAI HCKR Timing

Table 58 describes the general timing requirements for the ESAI module. Table 56 and Table 57 describe respectively the conditions and signals cited in Table 58.

Table 56. ESAI Timing Conditions

Symbol	Significance	Comments
i ck	Internal clock	In the i.MX25, the internal clock frequency is equal to the IP bus frequency (133 MHz)
x ck	External clock	The external clock may be derived from the CRM module or other external clock sources
i ck a	Internal clock, asynchronous mode	In asynchronous mode, SCKT and SCKR are different clocks
i ck s	Internal clock, synchronous mode	In synchronous mode, SCKT and SCKR are the same clock

Table 57. ESAI Signals

Signal Name	Significance
SCKT	Transmit clock
SCKR	Receive clock
FST	Transmit frame sync
HCKT	Transmit high-frequency clock
HCKR	Receive high-frequency clock

Table 58. ESAI General Timing Requirements

No.	Characteristics ^{1 2}	Symbol	Expression ³	Min.	Max.	Condition	Unit
62	Clock cycle ⁴	t_{SSICC}	$4 \times T_C$ $4 \times T_C$	30.0 30.0	— —	i ck i ck	ns
63	Clock high period For internal clock For external clock	— — —	— $2 \times T_C - 9.0$ $2 \times T_C$	— 6 15	— — —	— — —	ns
64	Clock low period For internal clock For external clock	— — —	— $2 \times T_C - 9.0$ $2 \times T_C$	— 6 15	— — —	— — —	ns

Table 58. ESAI General Timing Requirements (continued)

No.	Characteristics ^{1 2}	Symbol	Expression ³	Min.	Max.	Condition	Unit
65	SCKR rising edge to FSR out (bl) high	—	—	— —	17.0 7.0	x ck i ck a	ns
66	SCKR rising edge to FSR out (bl) low	—	—	— —	17.0 7.0	x ck i ck a	ns
67	SCKR rising edge to FSR out (wr) high ⁵	—	—	— —	19.0 9.0	x ck i ck a	ns
68	SCKR rising edge to FSR out (wr) low ⁵	—	—	— —	19.0 9.0	x ck i ck a	ns
69	SCKR rising edge to FSR out (wl) high	—	—	— —	16.0 6.0	x ck i ck a	ns
70	SCKR rising edge to FSR out (wl) low	—	—	— —	17.0 7.0	x ck i ck a	ns
71	Data in setup time before SCKR (SCK in synchronous mode) falling edge	—	—	12.0 19.0	— —	x ck i ck	ns
72	Data in hold time after SCKR falling edge	—	—	3.5 9.0	— —	x ck i ck	ns
73	FSR input (bl, wr) high before SCKR falling edge ⁵	—	—	2.0 12.0	— —	x ck i ck a	ns
74	FSR input (wl) high before SCKR falling edge	—	—	2.0 12.0	— —	x ck i ck a	ns
75	FSR input hold time after SCKR falling edge	—	—	2.5 8.5	— —	x ck i ck a	ns
76	Flags input setup before SCKR falling edge	—	—	0.0 19.0	— —	x ck i ck s	ns
77	Flags input hold time after SCKR falling edge	—	—	6.0 0.0	— —	x ck i ck s	ns
78	SCKT rising edge to FST out (bl) high	—	—	— —	18.0 8.0	x ck i ck	ns
79	SCKT rising edge to FST out (bl) low	—	—	— —	20.0 10.0	x ck i ck	ns
80	SCKT rising edge to FST out (wr) high ⁵	—	—	— —	20.0 10.0	x ck i ck	ns
81	SCKT rising edge to FST out (wr) low ⁵	—	—	— —	22.0 12.0	x ck i ck	ns
82	SCKT rising edge to FST out (wl) high	—	—	— —	19.0 9.0	x ck i ck	ns
83	SCKT rising edge to FST out (wl) low	—	—	— —	20.0 10.0	x ck i ck	ns
84	SCKT rising edge to data out enable from high impedance	—	—	— —	22.0 17.0	x ck i ck	ns
85	SCKT rising edge to transmitter #0 drive enable assertion	—	—	— —	17.0 11.0	x ck i ck	ns

Table 58. ESAI General Timing Requirements (continued)

No.	Characteristics ^{1 2}	Symbol	Expression ³	Min.	Max.	Condition	Unit
86	SCKT rising edge to data out valid	—	—	—	18.0 13.0	x ck i ck	ns
87	SCKT rising edge to data out high impedance ⁶	—	—	—	21.0 16.0	x ck i ck	ns
88	SCKT rising edge to transmitter #0 drive enable negation ⁶	—	—	—	14.0 9.0	x ck i ck	ns
89	FST input (bl, wr) setup time before SCKT falling edge ⁵	—	—	2.0 18.0	— —	x ck i ck	ns
90	FST input (wl) setup time before SCKT falling edge	—	—	2.0 18.0	— —	x ck i ck	ns
91	FST input hold time after SCKT falling edge	—	—	4.0 5.0	— —	x ck i ck	ns
92	FST input (wl) to data out enable from high impedance	—	—	—	21.0	—	ns
93	FST input (wl) to transmitter #0 drive enable assertion	—	—	—	14.0	—	ns
94	Flag output valid after SCKT rising edge	—	—	— —	14.0 9.0	x ck i ck	ns
95	HCKR/HCKT clock cycle	—	$2 \times T_C$	15	—	—	ns
96	HCKT input rising edge to SCKT output	—	—	—	18.0	—	ns
97	HCKR input rising edge to SCKR output	—	—	—	18.0	—	ns

¹ $V_{CORE_VDD} = 1.00 \pm 0.10$ V; $T_J = -40$ °C to 125 °C, $C_L = 50$ pF

² In the “Characteristics” column, bl = bit length, wl = word length, wr = word length relative

³ In the “Expression” column, $T_C = 7.5$ ns.

⁴ For the internal clock, the external clock cycle is defined by I_{cyc} and the ESAI control register.

⁵ The word-relative frame sync signal waveform relative to the clock operates in the same manner as the bit-length frame sync signal waveform, but spreads starting from one serial clock before the first bit clock (same as the bit length frame sync signal), until the second-to-last bit-clock of the first word in the frame.

⁶ Periodically sampled and not 100% tested.

3.7.8 Enhanced Secured Digital Host Controller (eSDHCv2) Timing

Figure 54 shows eSDHCv2 timing, and Table 59 describes the timing parameters (SD1–SD8) used in the figure. The following definitions apply to values and signals described in Table 59:

- LS: low-speed mode. Low-speed card can tolerate clocks up to 400 kHz
- FS: full-speed mode. Full-speed MMC card’s clock can reach 20 MHz; full speed SD/SDIO card clock can reach 25 MHz
- HS: high-speed mode. High-speed MMC card’s clock can reach 52 MHz; SD/SDIO card clock can reach 50 MHz

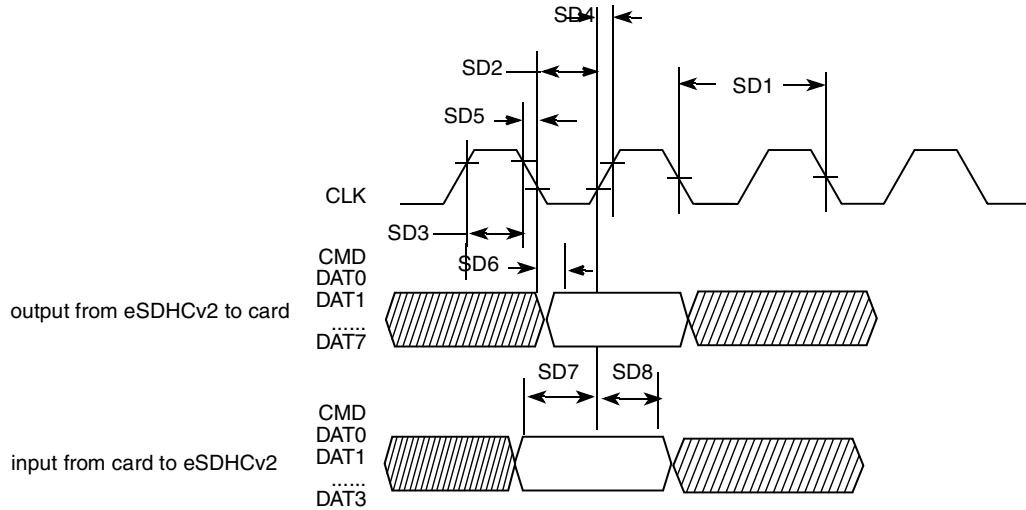

Figure 54. eSDHCv2 Timing

Table 59. eSDHCv2 Interface Timing Specification

ID	Parameter	Symbols	Min.	Max.	Unit
Card Input Clock					
SD1	Clock frequency (low speed)	f_{PP}^1	0	400	kHz
	Clock frequency (SD/SDIO full speed/high speed)	f_{PP}^2	0	25/50	MHz
	Clock frequency (MMC full speed/high speed)	f_{PP}^3	0	20/52	MHz
	Clock frequency (identification mode)	f_{OD}	100	400	kHz
SD2	Clock low time	t_{WL}	6.5	—	ns
SD3	Clock high time	t_{WH}	6.5	—	ns
SD4	Clock rise time	t_{TLH}	—	3	ns
SD5	Clock fall time	t_{THL}	—	3	ns
eSDHC Output / Card Inputs CMD, DAT (Reference to CLK)					
SD6	eSDHC output delay	t_{OD}	-3	3	ns
eSDHC Input / Card Outputs CMD, DAT (Reference to CLK)					
SD7	eSDHC input setup time	t_{ISU}	2.5	—	ns
SD8	eSDHC input hold time	t_{IH}^4	2.5	—	ns

¹ In low-speed mode, card clock must be lower than 400 kHz, voltage ranges from 2.7 to 3.6 V.

² In normal-speed mode for SD/SDIO card, clock frequency can be any value between 0 ~ 25 MHz. In high speed mode, clock frequency can be any value between 0 ~ 50 MHz.

³ In normal-speed mode for MMC card, clock frequency can be any value between 0 ~ 20 MHz. In high speed mode, clock frequency can be any value between 0 ~ 52 MHz.

⁴ To satisfy hold timing, the delay difference between clock input and cmd/data input must not exceed 2 ns.

3.7.9 Fast Ethernet Controller (FEC) Timing

The FEC is designed to support both 10- and 100-Mbps Ethernet networks compliant with the IEEE 802.3 standard. An external transceiver interface and transceiver function are required to complete the interface to the media. The FEC supports 10/100 Mbps MII (18 pins altogether), 10/100 Mbps RMII (ten pins, including serial management interface) and the 10-Mbps-only 7-Wire interface (which uses seven of the MII pins), for connection to an external Ethernet transceiver. All signals are compatible with transceivers operating at a voltage of 3.3 V.

The following subsections describe the timing for MII and RMII modes.

3.7.9.1 FEC MII Mode Timing

The following subsections describe MII receive, transmit, asynchronous inputs, and serial management signal timings.

3.7.9.1.4 MII Receive Signal Timing (FEC_RXD[3:0], FEC_RX_DV, FEC_RX_ER, and FEC_RX_CLK)

The receiver functions correctly up to an FEC_RX_CLK maximum frequency of 25 MHz + 1%. There is no minimum frequency requirement. Additionally, the processor clock frequency must exceed twice the FEC_RX_CLK frequency.

Figure 55 shows MII receive signal timings. Table 60 describes the timing parameters (M1–M4) shown in the figure.

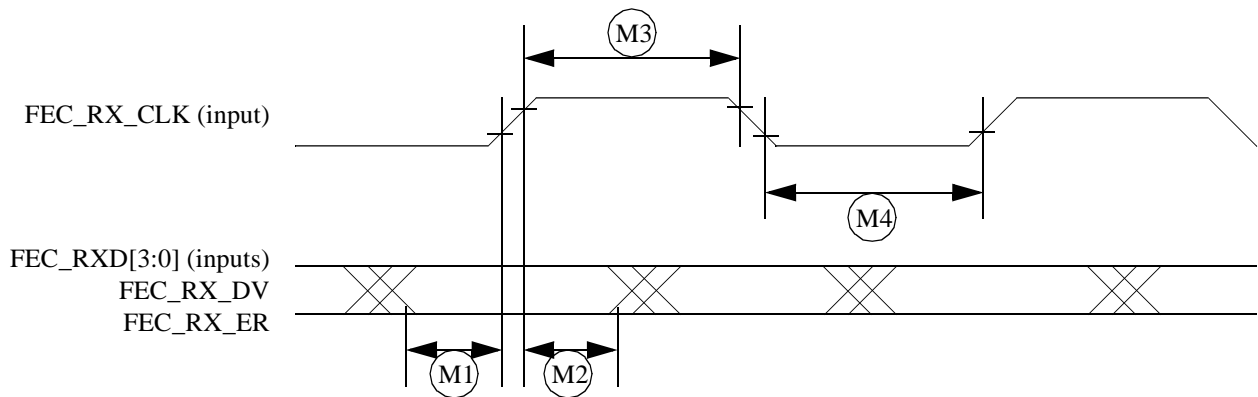

Figure 55. MII Receive Signal Timing Diagram

Table 60. MII Receive Signal Timing

ID	Characteristic ¹	Min.	Max.	Unit
M1	FEC_RXD[3:0], FEC_RX_DV, FEC_RX_ER to FEC_RX_CLK setup	5	—	ns
M2	FEC_RX_CLK to FEC_RXD[3:0], FEC_RX_DV, FEC_RX_ER hold	5	—	ns
M3	FEC_RX_CLK pulse width high	35%	65%	FEC_RX_CLK period
M4	FEC_RX_CLK pulse width low	35%	65%	FEC_RX_CLK period

¹ FEC_RX_DV, FEC_RX_CLK, and FEC_RXD0 have the same timing in 10 Mbps 7-wire interface mode.

3.7.9.1.5 MII Transmit Signal Timing (FEC_TXD[3:0], FEC_TX_EN, FEC_TX_ER, and FEC_TX_CLK)

The transmitter functions correctly up to an FEC_TX_CLK maximum frequency of 25 MHz + 1%. There is no minimum frequency requirement. Additionally, the processor clock frequency must exceed twice the FEC_TX_CLK frequency.

Figure 56 shows MII transmit signal timings. Table 61 describes the timing parameters (M5–M8) shown in the figure.

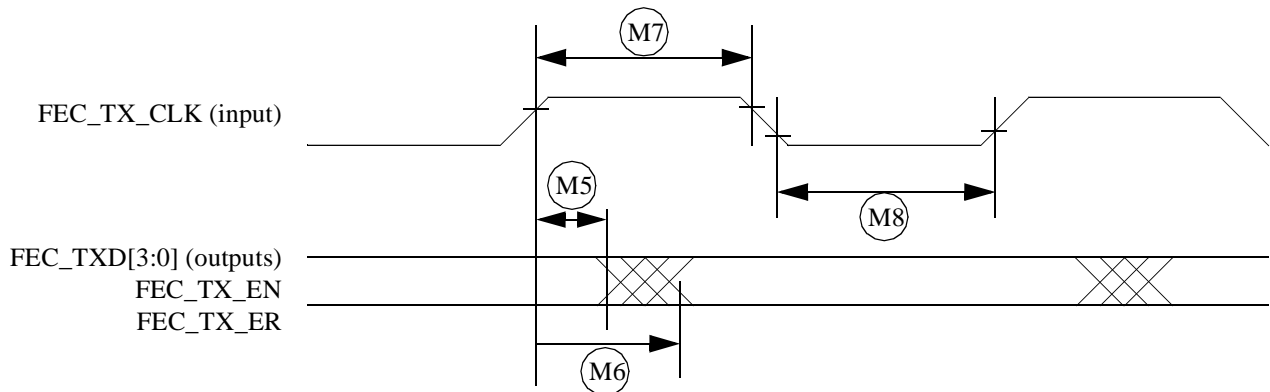

Figure 56. MII Transmit Signal Timing Diagram

Table 61. MII Transmit Signal Timing

ID	Characteristic ¹	Min.	Max.	Unit
M5	FEC_TX_CLK to FEC_TXD[3:0], FEC_TX_EN, FEC_TX_ER invalid	5	—	ns
M6	FEC_TX_CLK to FEC_TXD[3:0], FEC_TX_EN, FEC_TX_ER valid	—	20	ns
M7	FEC_TX_CLK pulse width high	35%	65%	FEC_TX_CLK period
M8	FEC_TX_CLK pulse width low	35%	65%	FEC_TX_CLK period

¹ FEC_TX_EN, FEC_TX_CLK, and FEC_TXD0 have the same timing in 10-Mbps 7-wire interface mode.

3.7.9.1.6 MII Asynchronous Inputs Signal Timing (FEC_CRS and FEC_COL)

Figure 57 shows MII asynchronous input timings. Table 62 describes the timing parameter (M9) shown in the figure.

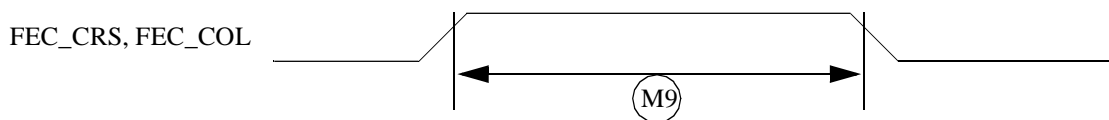

Figure 57. MII Async Inputs Timing Diagram

Table 62. MII Asynchronous Inputs Signal Timing

ID	Characteristic	Min.	Max.	Unit
M9 ¹	FEC_CRG to FEC_COL minimum pulse width	1.5	—	FEC_TX_CLK period

¹ FEC_COL has the same timing in 10-Mbit 7-wire interface mode.

3.7.9.2 MII Serial Management Channel Timing (FEC_MDIO and FEC_MDC)

The MDC frequency is designed to be equal to or less than 2.5 MHz to comply with the IEEE 802.3 standard MII specification. However the FEC can function correctly with a maximum MDC frequency of 15 MHz.

Figure 58 shows MII asynchronous input timings. Table 63 describes the timing parameters (M10—M15) shown in the figure.

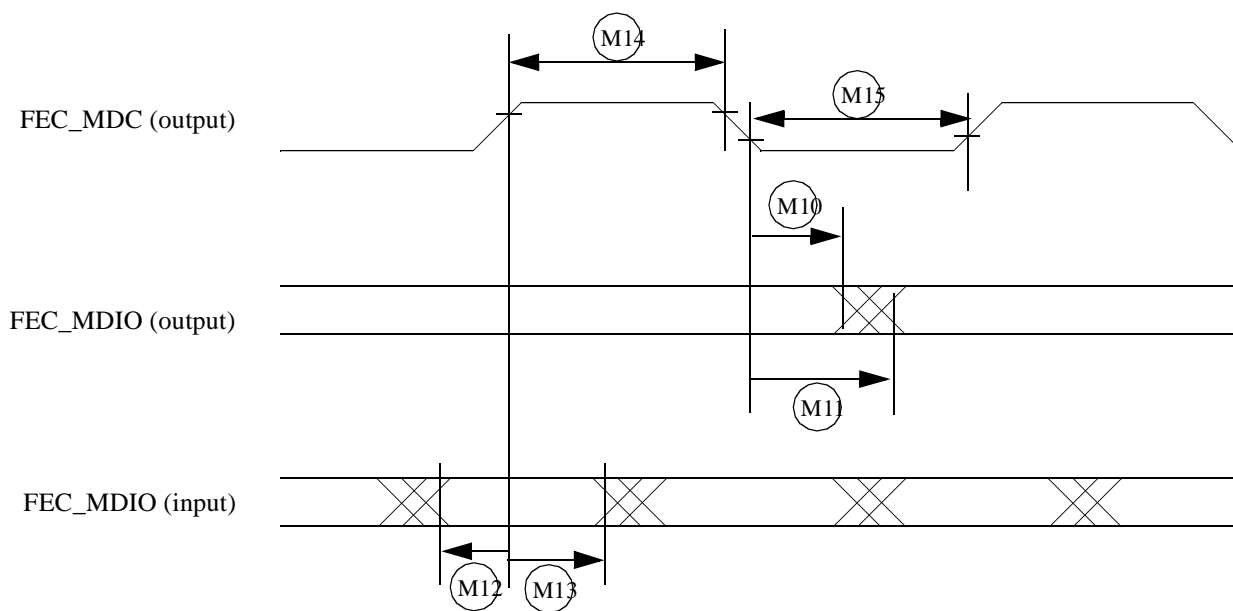

Figure 58. MII Serial Management Channel Timing Diagram

Table 63. MII Serial Management Channel Timing

ID	Characteristic	Min.	Max.	Unit
M10	FEC_MDC falling edge to FEC_MDIO output invalid (min. propagation delay)	0	—	ns
M11	FEC_MDC falling edge to FEC_MDIO output valid (max. propagation delay)	—	5	ns
M12	FEC_MDIO (input) to FEC_MDC rising edge setup	18	—	ns
M13	FEC_MDIO (input) to FEC_MDC rising edge hold	0	—	ns
M14	FEC_MDC pulse width high	40%	60%	FEC_MDC period
M15	FEC_MDC pulse width low	40%	60%	FEC_MDC period

3.7.9.3 RMII Mode Timing

In RMII mode, FEC_TX_CLK is used as the REF_CLK, which is a 50 MHz \pm 50 ppm continuous reference clock. FEC_RX_DV is used as the CRS_DV in RMII. Other signals under RMII mode include FEC_TX_EN, FEC_TXD[1:0], FEC_RXD[1:0] and FEC_RX_ER.

Figure 59 shows RMII mode timings. Table 64 describes the timing parameters (M16–M21) shown in the figure.

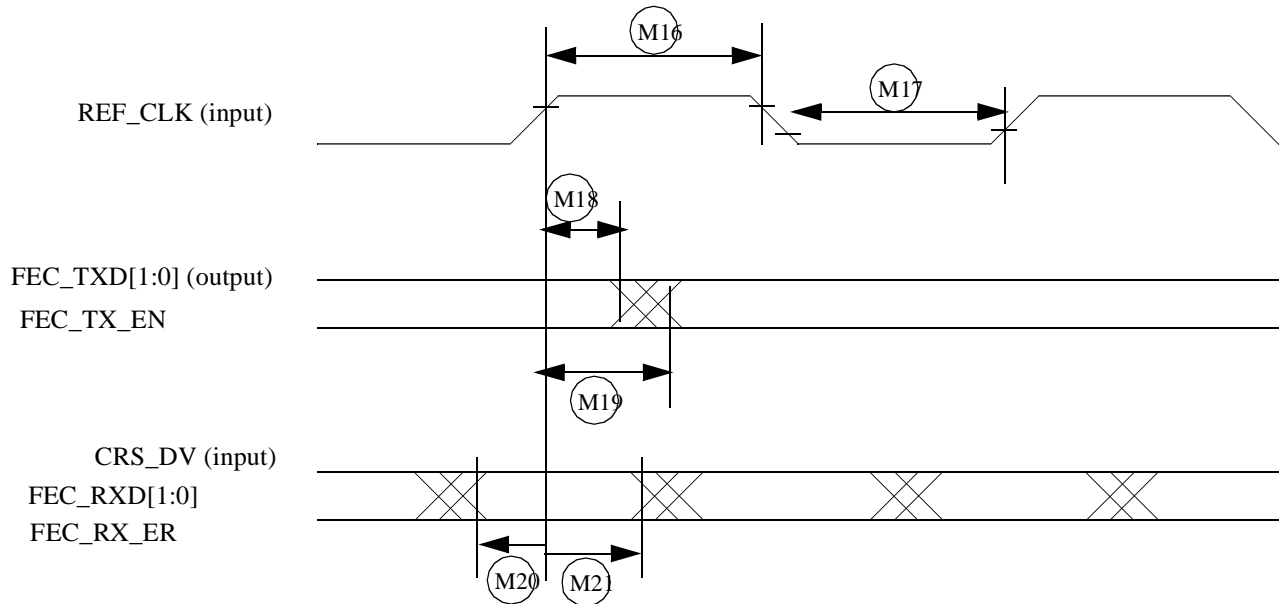

Figure 59. RMII Mode Signal Timing Diagram

Table 64. RMII Signal Timing

ID	Characteristic	Min.	Max.	Unit
M16	REF_CLK(FEC_TX_CLK) pulse width high	35%	65%	REF_CLK period
M17	REF_CLK(FEC_TX_CLK) pulse width low	35%	65%	REF_CLK period
M18	REF_CLK to FEC_TXD[1:0], FEC_TX_EN invalid	3	—	ns
M19	REF_CLK to FEC_TXD[1:0], FEC_TX_EN valid	—	12	ns
M20	FEC_RXD[1:0], CRS_DV(FEC_RX_DV), FEC_RX_ER to REF_CLK setup	2	—	ns
M21	REF_CLK to FEC_RXD[1:0], FEC_RX_DV, FEC_RX_ER hold	2	—	ns

3.7.10 Controller Area Network (FlexCAN) Transceiver Parameters and Timing

Table 65 and Table 66 show voltage requirements for the FlexCAN transceiver Tx and Rx pins.

Table 65. Tx Pin Characteristics

Parameter	Symbol	Min.	Typ.	Max.	Units
High-level output voltage	VOH	2	—	$V_{CC}^1 + 0.3$	V
Low-level output voltage	VOL	—	0.8	—	V

¹ $V_{CC} = +3.3\text{ V} \pm 5\%$

Table 66. Rx Pin Characteristics

Parameter	Symbol	Min.	Typ.	Max.	Units
High-level input voltage	VIH	$0.8 \times V_{CC}^1$	—	V_{CC}^1	V
Low-level input voltage	VIL	—	0.4	—	V

¹ $V_{CC} = +3.3\text{ V} \pm 5\%$

Figure 60 through Figure 63 show the FlexCAN timing, including timing of the standby and shutdown signals.

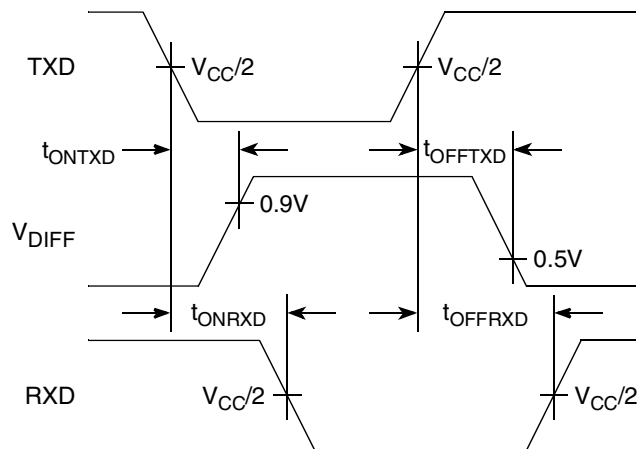

Figure 60. FlexCAN Timing Diagram

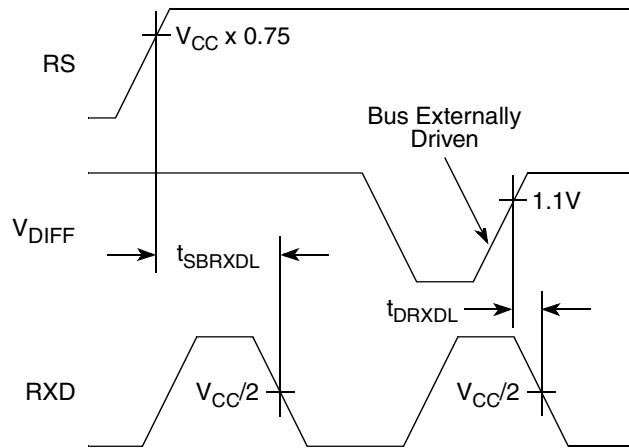

Figure 61. Timing Diagram for FlexCAN Standby Signal

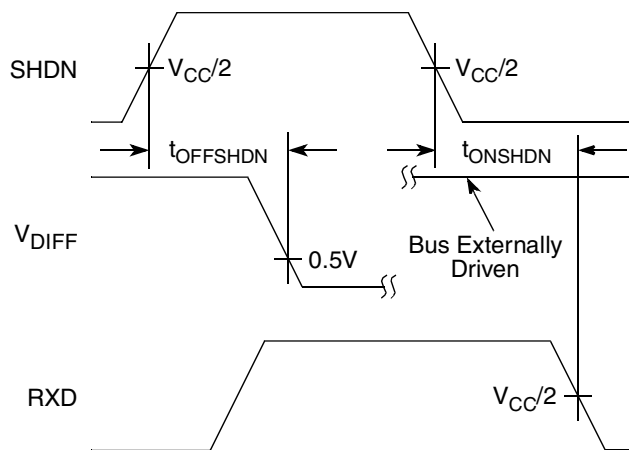

Figure 62. Timing Diagram for FlexCAN Shutdown Signal

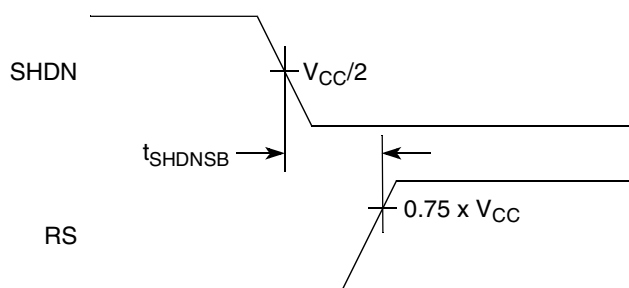

Figure 63. Timing Diagram for FlexCAN Shutdown-to-Standby Signal

Because integer multiples are not possible, taking into account the range of frequencies at which the SoC has to operate, DPLLs work in FOL mode only.

3.7.11 Inter IC Communication (I²C) Timing

The I²C communication protocol consists of the following seven elements:

- Start
- Data source/recipient
- Data direction
- Slave acknowledge
- Data
- Data acknowledge
- Stop

Figure 64 shows the timing of the I²C module. Table 67 and Table 68 describe the I²C module timing parameters (IC1–IC6) shown in the figure.

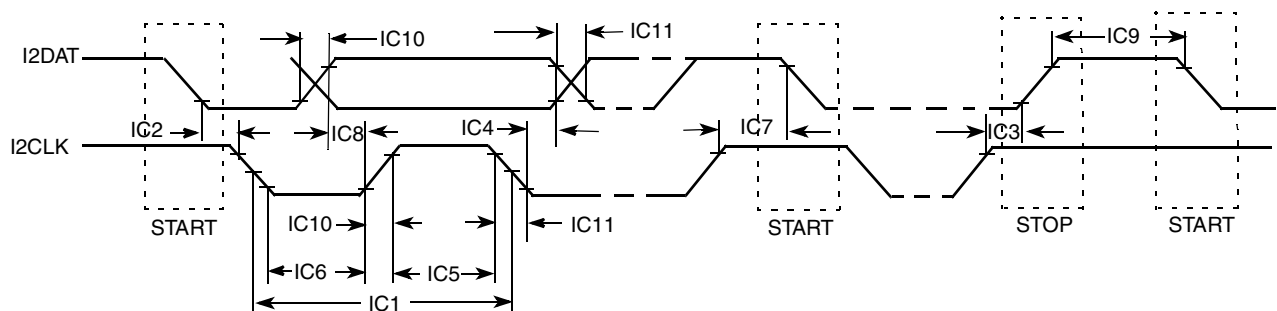

Figure 64. I²C Module Timing Diagram

Table 67. I2C Module Timing Parameters: 3.0 V +/-0.30 V

ID	Parameter	Standard Mode		Fast Mode		Unit
		Min.	Max.	Min.	Max.	
IC1	I2CLK cycle time	10	-	2.5	-	μs
IC2	Hold time (repeated) START condition	4.0	-	0.6	-	μs
IC3	Set-up time for STOP condition	4.0	-	0.6	-	μs
IC4	Data hold time	0 ¹	3.45 ²	0 ¹	0.9 ²	μs
IC5	HIGH Period of I2CLK Clock	4.0	-	0.6	-	μs
IC6	LOW Period of the I2CLK Clock	4.7	-	1.3	-	μs
IC7	Set-up time for a repeated START condition	4.7	-	0.6	-	μs
IC8	Data set-up time	250	-	100 ³	-	ns
IC9	Bus free time between a STOP and START condition	4.7	-	1.3	-	μs
IC10	Rise time of both I2DAT and I2CLK signals	-	1000	20+0.1C _b ⁴	300	ns
IC11	Fall time of both I2DAT and I2CLK signals	-	300	20+0.1C _b ⁴	300	ns
IC12	Capacitive load for each bus line (C _b)	-	400	-	400	pF

- ¹ A device must internally provide a hold time of at least 300 ns for I2DAT signal in order to bridge the undefined region of the falling edge of I2CLK.
- ² The maximum hold time has only to be met if the device does not stretch the LOW period (ID no IC5) of the I2CLK signal
- ³ A Fast-mode I2C-bus device can be used in a Standard-mode I2C-bus system, but the requirement of Set-up time (ID No IC7) of 250 ns must then be met. This is automatically the case if the device does not stretch the LOW period of the I2CLK signal. If such a device does stretch the LOW period of the I2CLK signal, it must output the next data bit to the I2DAT line $\text{max_rise_time}(\text{ID No IC9}) + \text{data_setup_time}(\text{ID No IC7}) = 1000 + 250 = 1250 \text{ ns}$ (according to the Standard-mode I2C-bus specification) before the I2CLK line is released.
- ⁴ C_b = total capacitance of one bus line in pF.

Table 68. I2C Module Timing Parameters: 1.8 V +/- 0.10 V

ID	Parameter	Standard Mode		Unit
		Min.	Max.	
IC1	I2CLK cycle time	10	-	μs
IC2	Hold time (repeated) START condition	4.0	-	μs
IC3	Set-up time for STOP condition	4.0	-	μs
IC4	Data hold time	0 ¹	3.45 ²	μs
IC5	HIGH Period of I2CLK Clock	4.0	-	μs
IC6	LOW Period of the I2CLK Clock	4.7	-	μs
IC7	Set-up time for a repeated START condition	4.7	-	μs
IC8	Data set-up time	250	-	ns
IC9	Bus free time between a STOP and START condition	4.7	-	μs
IC10	Rise time of both I2DAT and I2CLK signals	-	1000	ns
IC11	Fall time of both I2DAT and I2CLK signals	-	300	ns
IC12	Capacitive load for each bus line (C_b)	-	400	pF

- ¹ A device must internally provide a hold time of at least 300 ns for I2DAT signal in order to bridge the undefined region of the falling edge of I2CLK.
- ² The maximum hold time has only to be met if the device does not stretch the LOW period (ID no IC5) of the I2CLK signal

3.7.12 Liquid Crystal Display Controller (LCDC) Timing

Figure 65 and Figure 66 show LCDC timing in non-TFT and TFT mode respectively, and Table 69 and Table 70 list the timing parameters used in the associated figures.

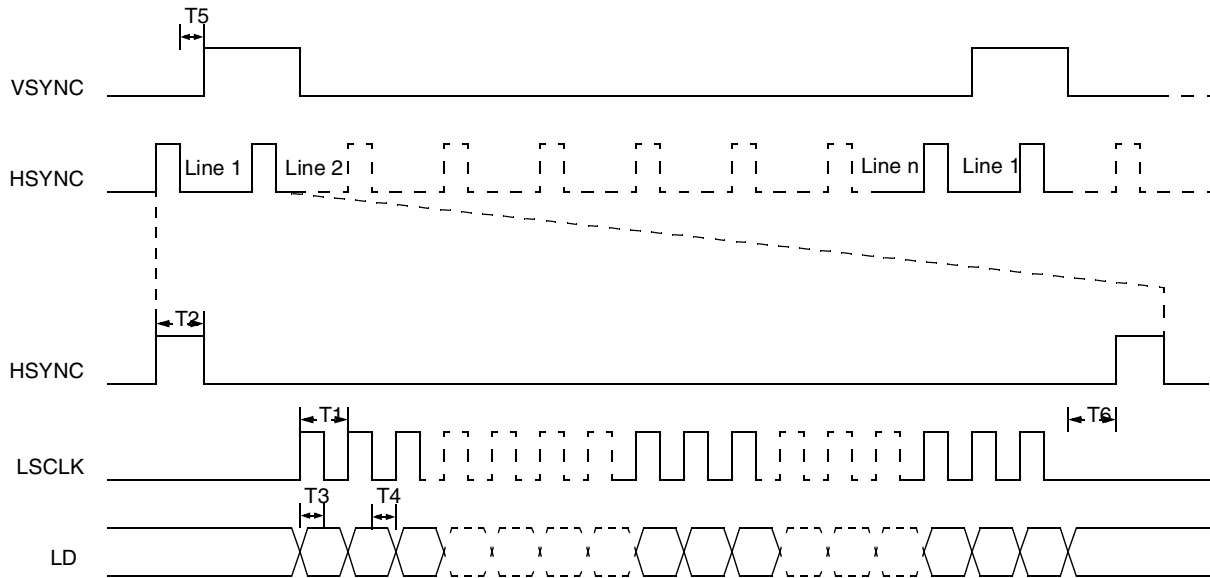

Figure 65. LCDC Non-TFT Mode Timing Diagram

Table 69. LCDC Non-TFT Mode Timing Parameters

ID	Description	Min.	Max.	Unit
T1	Pixel clock period	22.5	1000	ns
T2	HSYNC width	1	—	T^1
T3	LD setup time	5	—	ns
T4	LD hold time	5	—	ns
T5	Wait between HSYNC and VSYNC rising edge	2	—	T^1
T6	Wait between last data and HSYNC rising edge	1	—	T^1

¹ T is pixel clock period

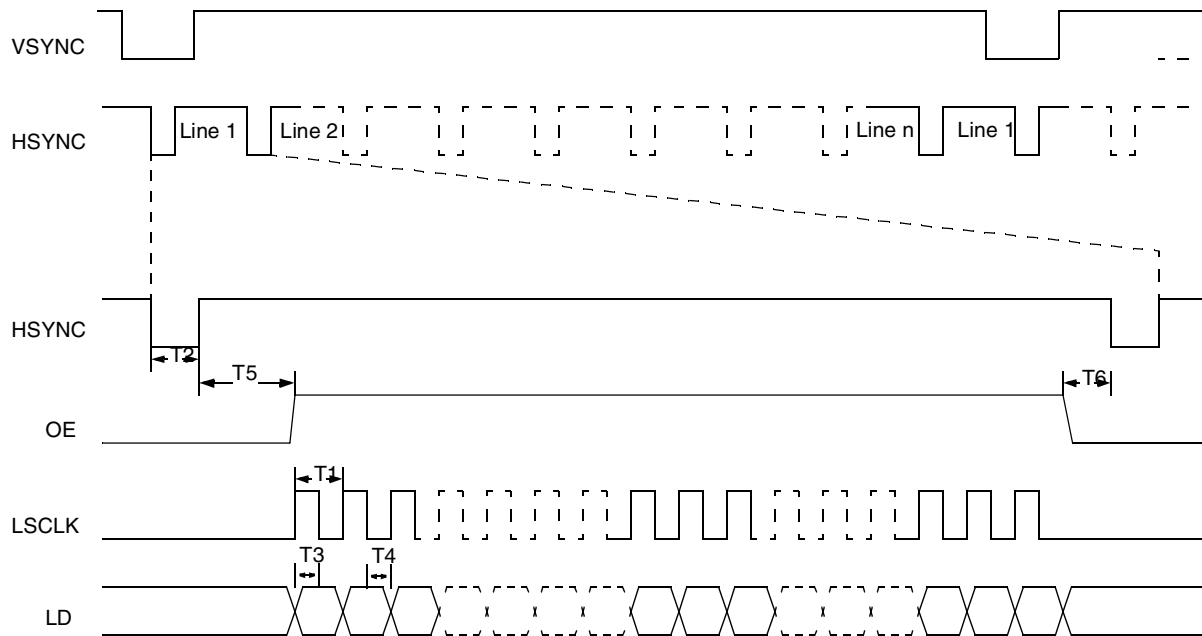

Figure 66. LCD TFT Mode Timing Diagram

Table 70. LCD TFT Mode Timing Parameters

ID	Description	Min.	Ma	Unit
T1	Pixel clock period	22.5	1000	ns
T2	HSYNC width	1	—	T ¹
T3	LD setup time	5	—	ns
T4	LD hold time	5	—	ns
T5	Delay from the end of HSYNC to the beginning of the OE pulse	3	—	T ¹
T6	Delay from end of OE to the beginning of the HSYNC pulse	1	—	T ¹

¹ T is pixel clock period

3.7.13 Pulse Width Modulator (PWM) Timing Parameters

Figure 67 depicts the timing of the PWM, and Table 71 lists the PWM timing characteristics.

The PWM can be programmed to select one of three clock signals as its source frequency. The selected clock signal is passed through a prescaler before being input to the counter. The output is available at the pulse width modulator output (PWMO) external pin.

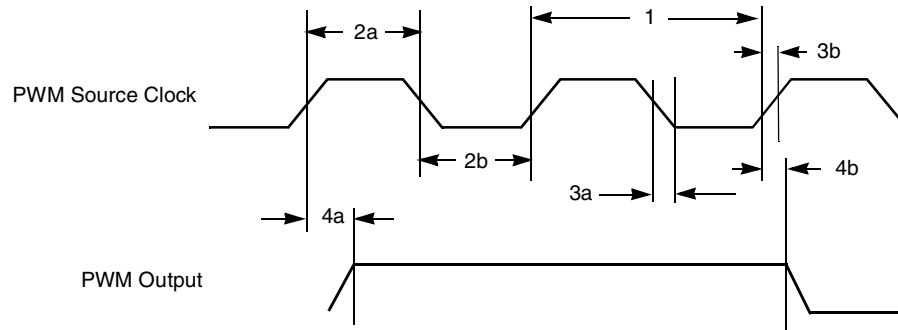

Figure 67. PWM Timing

Table 71. PWM Output Timing Parameter

Ref No.	Parameter	Minimum	Maximum	Unit
1	System CLK frequency ¹	0	ipg_clk	MHz
2a	Clock high time	12.29	—	ns
2b	Clock low time	9.91	—	ns
3a	Clock fall time	—	0.5	ns
3b	Clock rise time	—	0.5	ns
4a	Output delay time	—	9.37	ns
4b	Output setup time	8.71	—	ns

¹ CL of PWMO = 30 pF

3.7.14 Subscriber Identity Module (SIM) Timing

Each SIM module interface consists of a total of 12 pins (two separate ports, each containing six signals). Typically a port uses five signals.

The interface is designed to be used with synchronous SIM cards, meaning the SIM module provides the clock used by the SIM card. The clock frequency is typically 372 times the Tx/Rx data rate; however, the SIM module can also work with CLK frequencies of 16 times the Tx/Rx data rate.

There is no timing relationship between the clock and the data. The clock that the SIM module provides to the SIM card is used by the SIM card to recover the clock from the data in the same manner as standard UART data exchanges. All six signals (five for bidirectional Tx/Rx) of the SIM module are asynchronous with each other.

There are no required timing relationships between signals in normal mode. The SIM card is initiated by the interface device; the SIM card responds with Answer to Reset. Although the SIM interface has no defined requirements, the ISO/IEC 7816 defines reset and power-down sequences (for detailed information see ISO/IEC 7816).

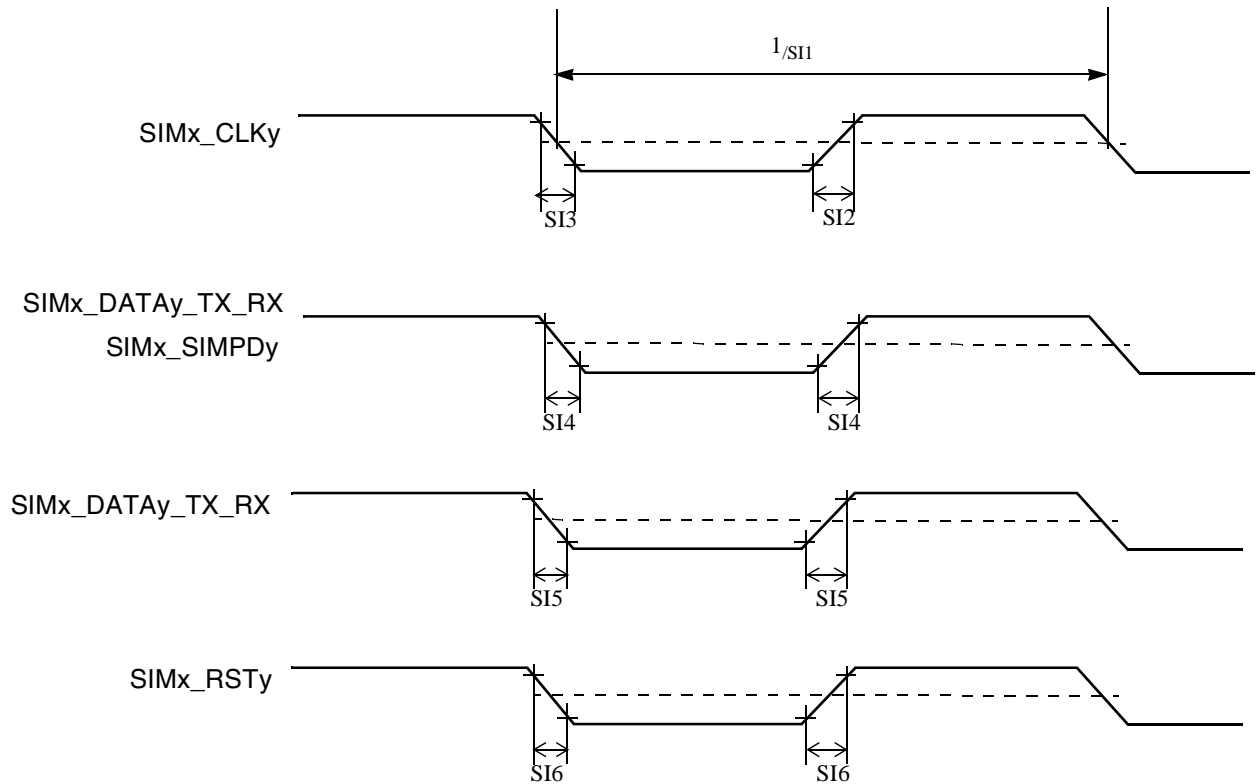

Figure 68. SIM Clock Timing Diagram

Table 72 defines the general timing requirements for the SIM interface.

Table 72. Timing Specifications, High Drive Strength

ID	Parameter	Symbol	Min.	Max.	Unit
SI1	SIM clock frequency (SIMx_CLKy) ¹	S_{freq}	0.01	25	MHz
SI2	SIM clock rise time (SIMx_CLKy) ²	S_{rise}	—	$0.09 \times (1/S_{freq})$	ns
SI3	SIM clock fall time (SIMx_CLKy) ³	S_{fall}	—	$0.09 \times (1/S_{freq})$	ns
SI4	SIM input transition time (SIMx_DATAy_RX_TX, SIMx_SIMPDy)	S_{trans}	10	25	ns
SI5	SIM I/O rise time / fall time (SIMx_DATAy_RX_TX) ⁴	Tr/Tf	—	1	us
SI6	SIM RST rise time / fall time (SIMx_RSTy) ⁵	Tr/Tf	—	1	us

¹ 50% duty cycle clock,

² With C = 50 pF

³ With C = 50 pF

⁴ With Cin = 30 pF, Cout = 30 pF,

⁵ With Cin = 30 pF,

3.7.14.1 SIM Reset Sequences

SIM cards may have internal reset, or active low reset. The following subset describes the reset sequences in these two cases.

3.7.14.1.1 SIM Cards with Internal Reset

Figure 69 shows the reset sequence for SIM cards with internal reset. The reset sequence comprises the following steps:

- After power-up, the clock signal is enabled on SIM_x_CLK_y (time T₀)
- After 200 clock cycles, SIM_x_DATA_y_RX_TX must be asserted.
- The card must send a response on SIM_x_DATA_y_RX_TX acknowledging the reset between 400–40000 clock cycles after T₀.

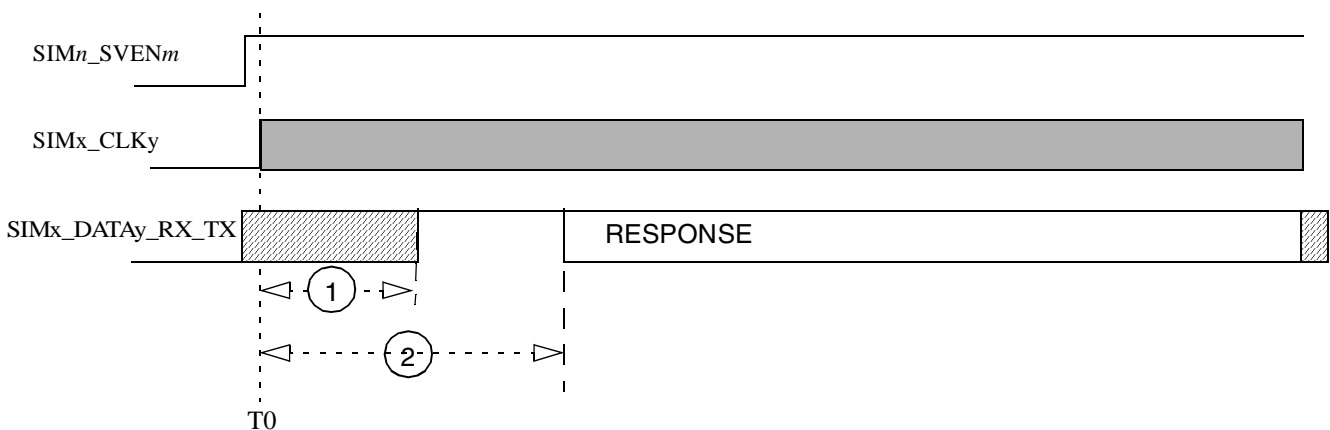

Figure 69. Internal Reset Card Reset Sequence

Table 73 defines the general timing requirements for the SIM interface.

Table 73. Timing Specifications, Internal Reset Card Reset Sequence

Ref No.	Min.	Max.	Units
1	—	200	clk cycles
2	400	40,000	clk cycles

3.7.14.1.2 SIM Cards with Active Low Reset

Figure 70 shows the reset sequence for SIM cards with active low reset. The reset sequence comprises the following steps:

- After power-up, the clock signal is enabled on SIM_x_CLK_y (time T₀)
- After 200 clock cycles, SIM_x_DATA_y_RX_TX must be asserted.
- SIM_x_RST_y must remain low for at least 40,000 clock cycles after T₀ (no response is to be received on RX during those 40,000 clock cycles)
- SIM_x_RST_y is asserted (at time T₁)
- SIM_x_RST_y must remain asserted for at least 40,000 clock cycles after T₁, and a response must be received on SIM_x_DATA_y_RX_TX between 400 and 40,000 clock cycles after T₁.

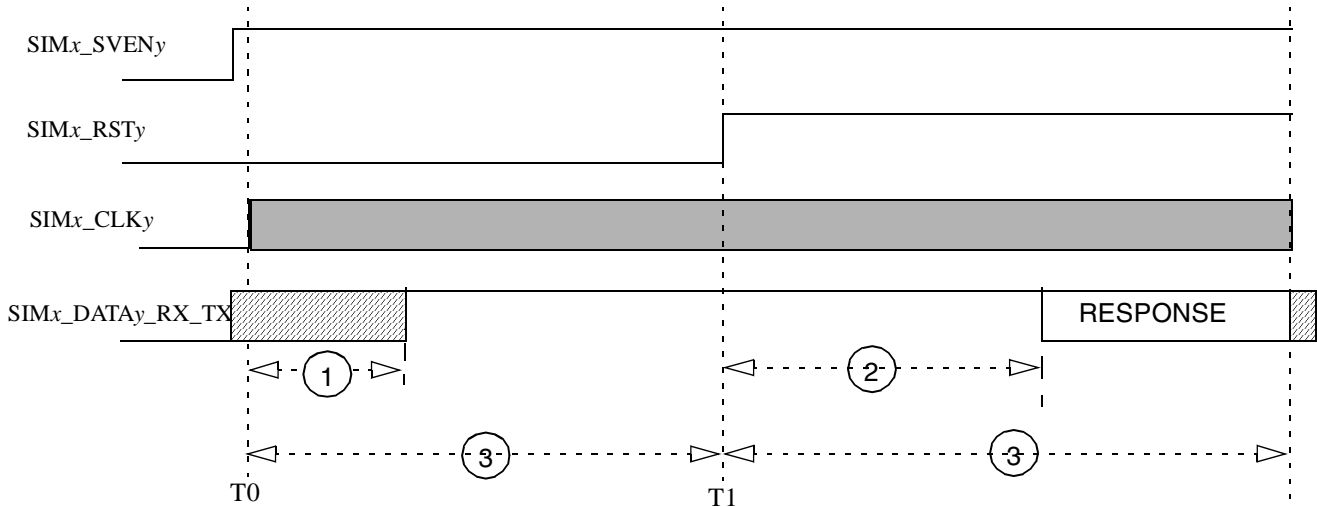

Figure 70. Active-Low-Reset SIM Card Reset Sequence

Table 74 defines the general timing requirements for the SIM interface.

Table 74. Timing Specifications, Active-Low-Reset SIM Card Reset Sequence

Ref No.	Min.	Max.	Unit
1	—	200	clk cycles
2	400	40,000	clk cycles
3	40,000	—	clk cycles

3.7.14.2 SIM Power-Down Sequence

Figure 71 shows the SIM interface power-down AC timing diagram. Table 75 shows the timing requirements for parameters (SI7–SI10) shown in the figure.

The power-down sequence for the SIM interface is as follows:

- SIMx_SIMPDy port detects the removal of the SIM Card
- SIMx_RSTy is negated
- SIMx_CLKy is negated
- SIMx_DATAy_RX_TX is negated
- SIMx_SVENy is negated

Each of the above steps requires one CKIL period (usually 32 kHz). Power-down may be initiated by a SIM card removal detection; or it may be launched by the processor.

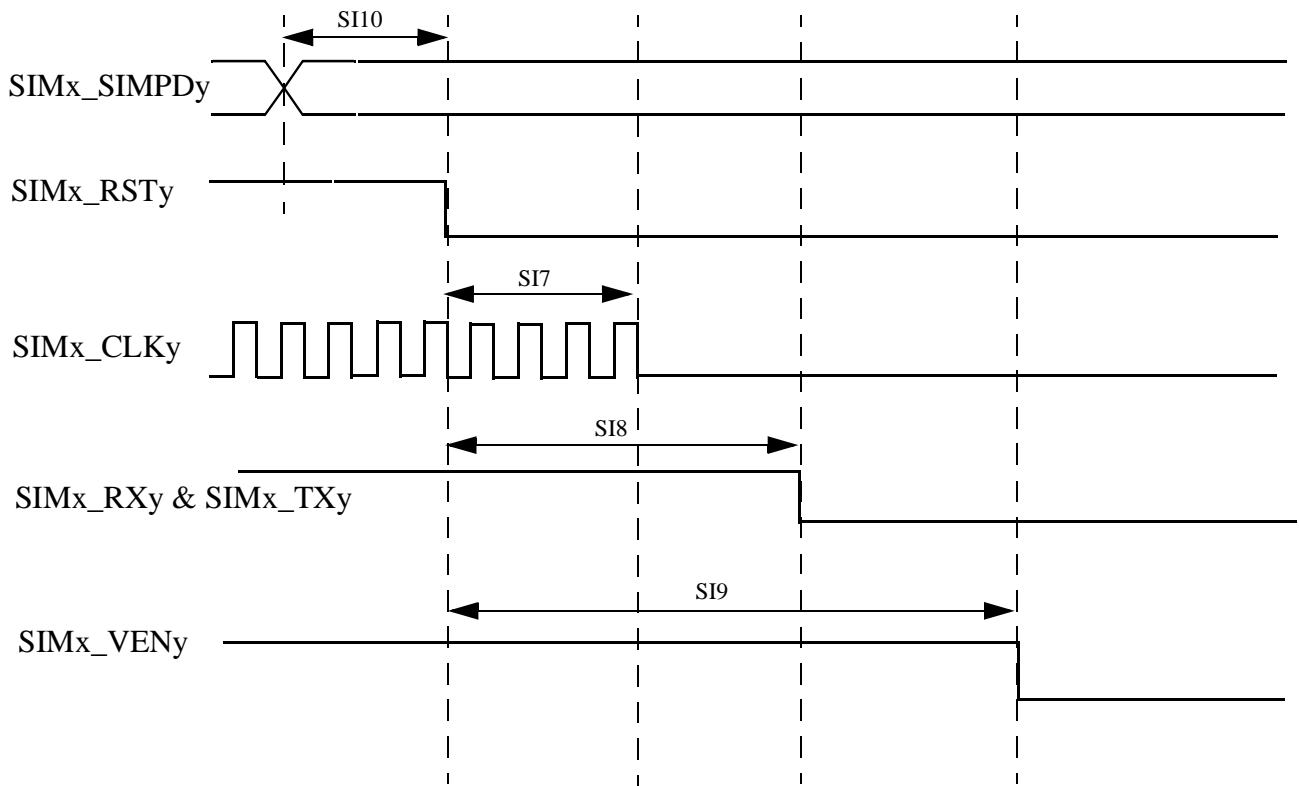

Figure 71. SmartCard Interface Power Down AC Timing

Table 75. Timing Requirements for Power-down Sequence

ID	PARAMETER	SYMBOL	Min.	Max.	Unit
SI7	SIM reset to SIM clock stop	$S_{rst2clk}$	$0.9 \times 1/F_{ckil}$	$1.1 \times 1/F_{ckil}$	ns
SI8	SIM reset to SIM Tx data low	$S_{rst2dat}$	$1.8 \times 1/F_{ckil}$	$2.2 \times 1/F_{ckil}$	ns
SI9	SIM reset to SIM voltage enable low	$S_{rst2ven}$	$2.7 \times 1/F_{ckil}$	$3.3 \times 1/F_{ckil}$	ns
SI10	SIM presence detect to SIM reset low	S_{pd2rst}	$0.9 \times 1/F_{ckil}$	$1.1 \times 1/F_{ckil}$	ns

3.7.15 System JTAG Controller (SJC) Timing

Figure 72 through Figure 75 show respectively the test clock input, boundary scan, test access port, and TRST timings for the SJC. Table 76 describes the SJC timing parameters (SJ1–SJ13) indicated in the figures.

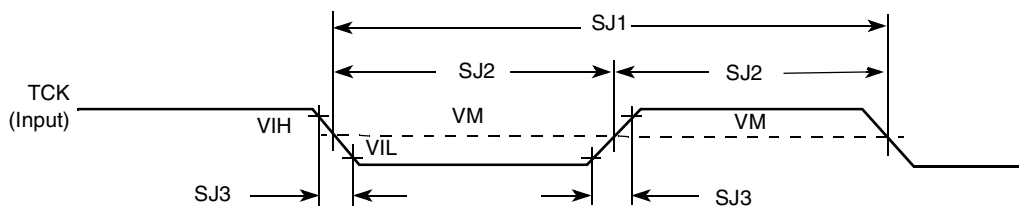

Figure 72. Test Clock Input Timing Diagram

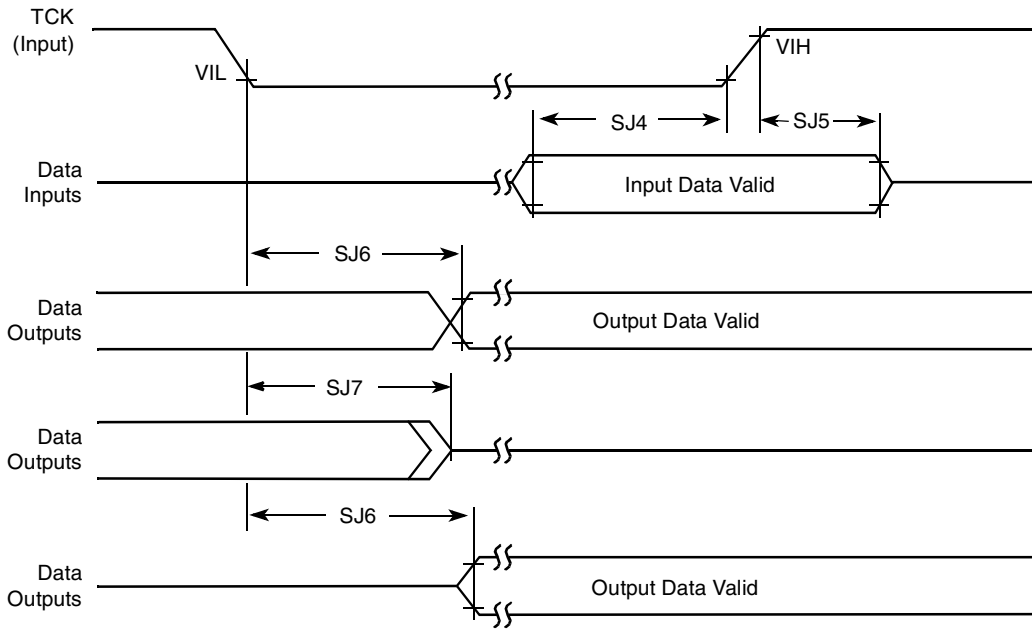

Figure 73. Boundary Scan (JTAG) Timing Diagram

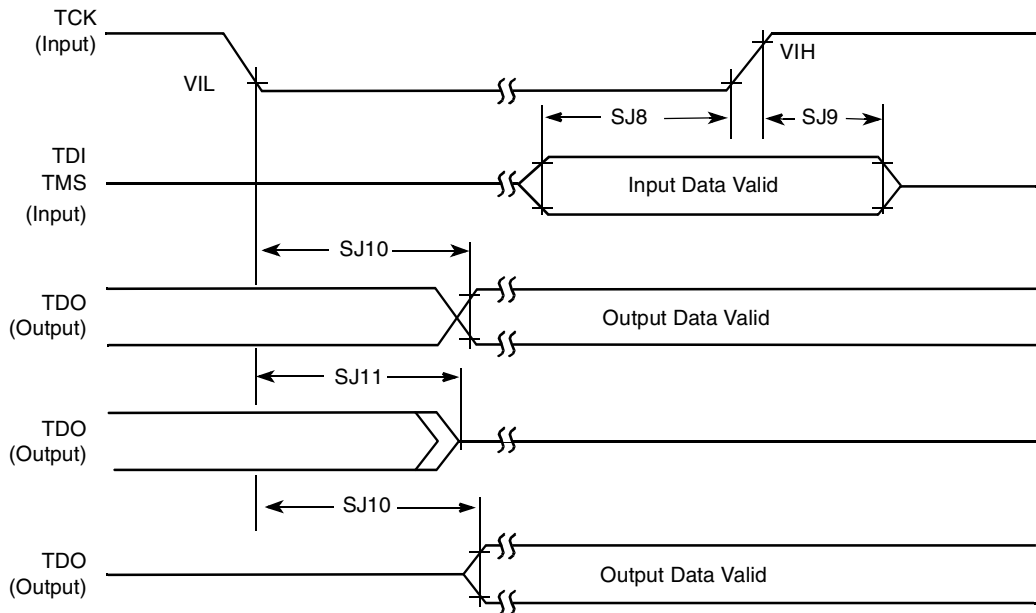

Figure 74. Test Access Port Timing Diagram

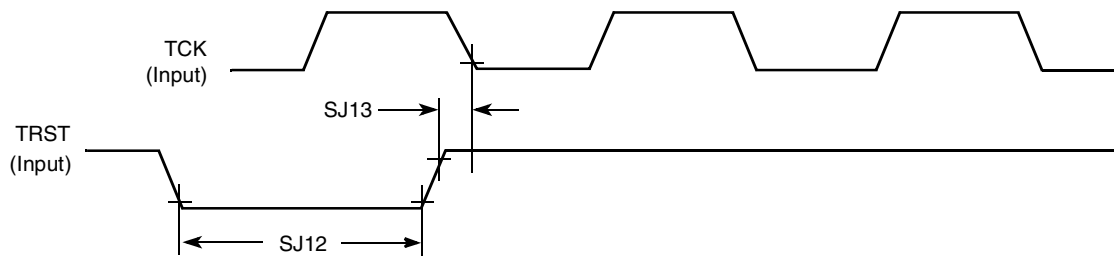

Figure 75. $\overline{\text{TRST}}$ Timing Diagram

Table 76. SJC Timing Parameters

ID	Parameter	All Frequencies		Unit
		Min.	Max.	
SJ1	TCK cycle time	100 ¹	—	ns
SJ2	TCK clock pulse width measured at V_M ²	40	—	ns
SJ3	TCK rise and fall times	—	3	ns
SJ4	Boundary scan input data set-up time	10	—	ns
SJ5	Boundary scan input data hold time	50	—	ns
SJ6	TCK low to output data valid	—	50	ns
SJ7	TCK low to output high impedance	—	50	ns
SJ8	TMS, TDI data set-up time	10	—	ns
SJ9	TMS, TDI data hold time	50	—	ns
SJ10	TCK low to TDO data valid	—	44	ns
SJ11	TCK low to TDO high impedance	—	44	ns
SJ12	$\overline{\text{TRST}}$ assert time	100	—	ns
SJ13	$\overline{\text{TRST}}$ set-up time to TCK low	40	—	ns

¹ In cases where SDMA TAP is put in the chain, the maximum TCK frequency is limited by the maximum ratio of 1:8 of SDMA core frequency to TCK. This implies a maximum frequency of 8.25 MHz (or 121.2 ns) for a 66 MHz IPG clock.

² V_M - mid point voltage

3.7.16 Smart Liquid Crystal Display Controller (SLCDC)

Figure 76 and Figure 77 show SLCDC timing for serial and parallel transfers respectively. Table 77 and Table 78 describe the timing parameters shown in the respective figures.

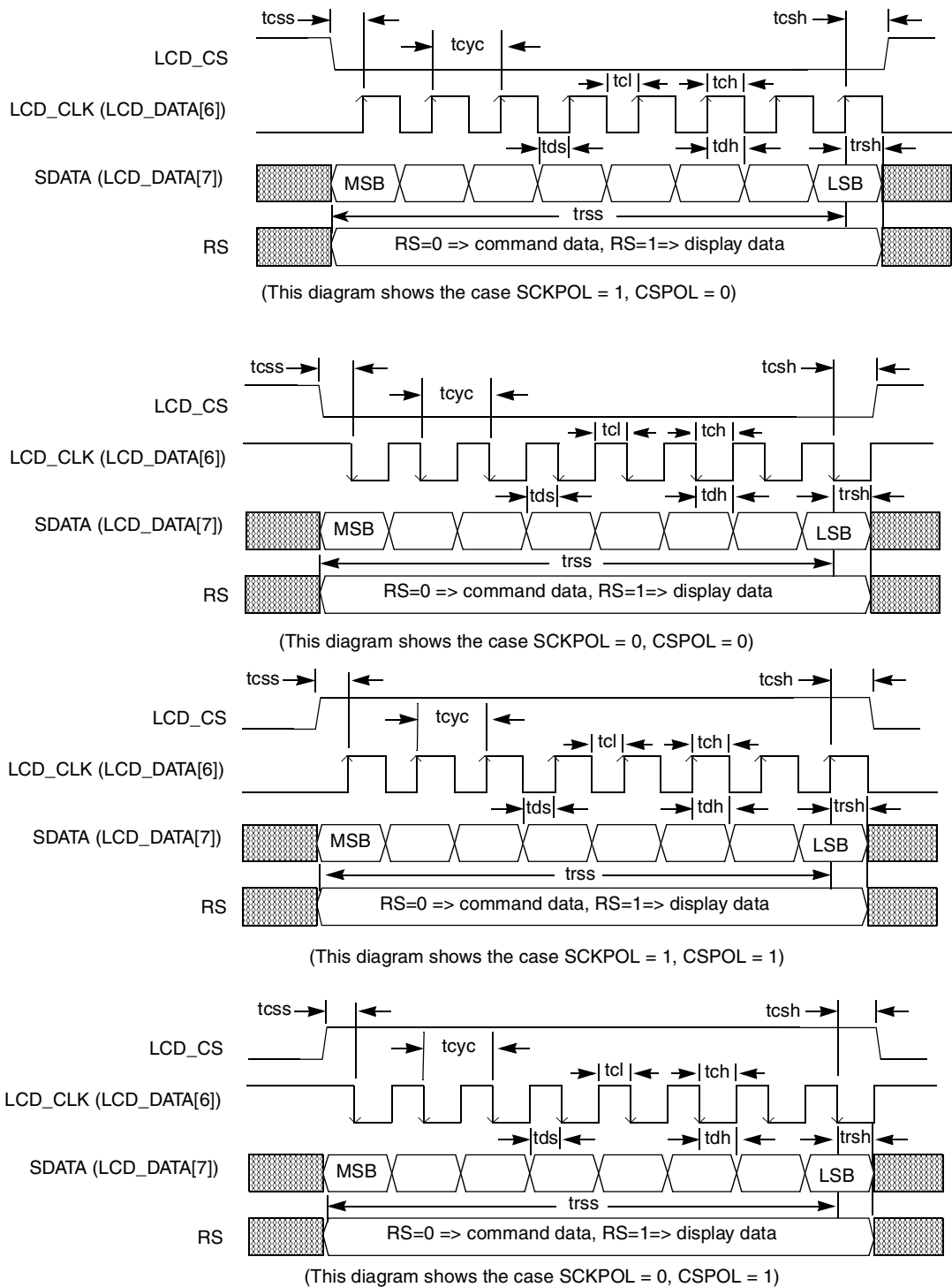

Figure 76. SLCDC Timing Diagram—Serial Transfers to LCD Device

Table 77. SLCDC Serial Interface Timing Parameters

Symbol	Parameter	Min.	Typ.	Max.	Units
t_{css}	Chip select setup time	$(t_{cyc} / 2) (\pm) t_{prop}$	—	—	ns
t_{csh}	Chip select hold time	$(t_{cyc} / 2) (\pm) t_{prop}$	—	—	ns
t_{cyc}	Serial clock cycle time	$39 (\pm) t_{prop}$	—	2641	ns
t_{cl}	Serial clock low pulse	$18 (\pm) t_{prop}$	—	—	ns
t_{ch}	Serial clock high pulse	$18 (\pm) t_{prop}$	—	—	ns
t_{ds}	Data setup time	$(t_{cyc} / 2) (\pm) t_{prop}$	—	—	ns
t_{dh}	Data hold time	$(t_{cyc} / 2) (\pm) t_{prop}$	—	—	ns
t_{rss}	Register select setup time	$(15 \times t_{cyc} / 2) (\pm) t_{prop}$	—	—	ns
t_{rsh}	Register select hold time	$(t_{cyc} / 2) (\pm) t_{prop}$	—	—	ns

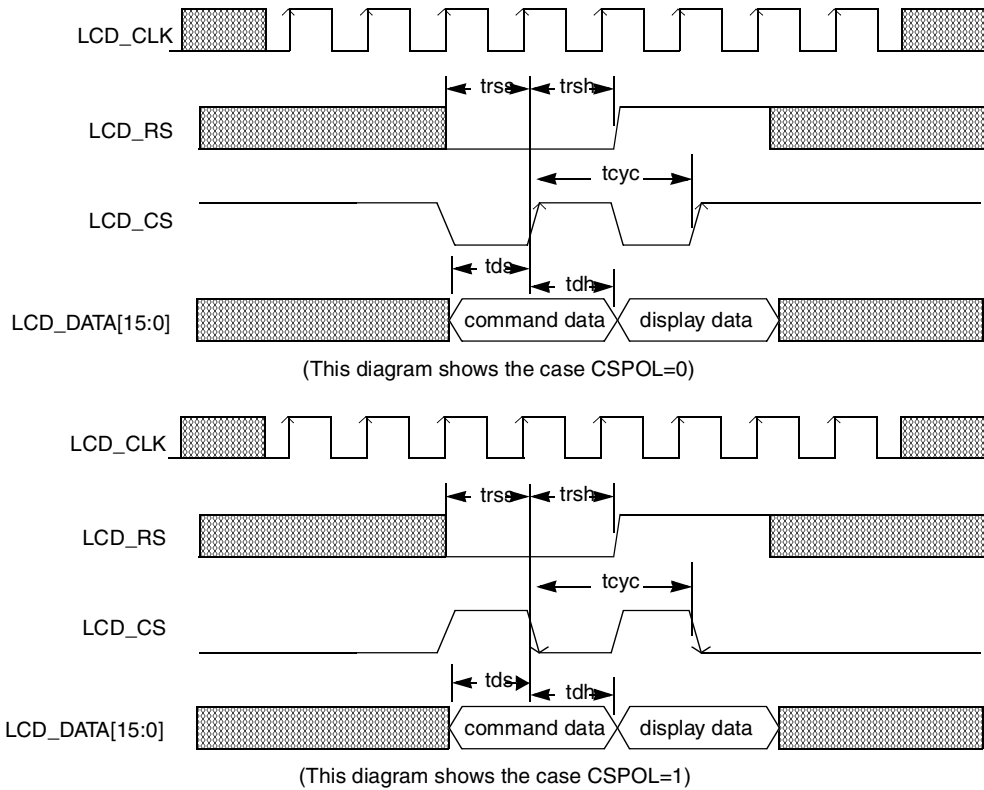

Figure 77. SLCDC Timing Diagram—Parallel Transfers to LCD Device

Table 78. SLCDC Parallel Interface Timing Parameters

Symbol	Parameter	Min.	Typ.	Max.	Units
t_{cyc}	Parallel clock cycle time	$78 (\pm) t_{prop}$	—	4923	ns
t_{ds}	Data setup time	$(t_{cyc} / 2) (\pm) t_{prop}$	—	—	—
t_{dh}	Data hold time	$(t_{cyc} / 2) (\pm) t_{prop}$	—	—	—
t_{rss}	Register select setup time	$(t_{cyc} / 2) (\pm) t_{prop}$	—	—	—
t_{rsh}	Register select hold time	$(t_{cyc} / 2) (\pm) t_{prop}$	—	—	—

3.7.17 Synchronous Serial Interface (SSI) Timing

The following subsections describe SSI timing in four cases:

- Transmitter with external clock
- Receiver with external clock
- Transmitter with internal clock
- Receiver with internal clock

3.7.17.1 SSI Transmitter Timing with Internal Clock

Figure 78 shows the timing for SSI transmitter with internal clock, and Table 79 describes the timing parameters (SS1–SS52).

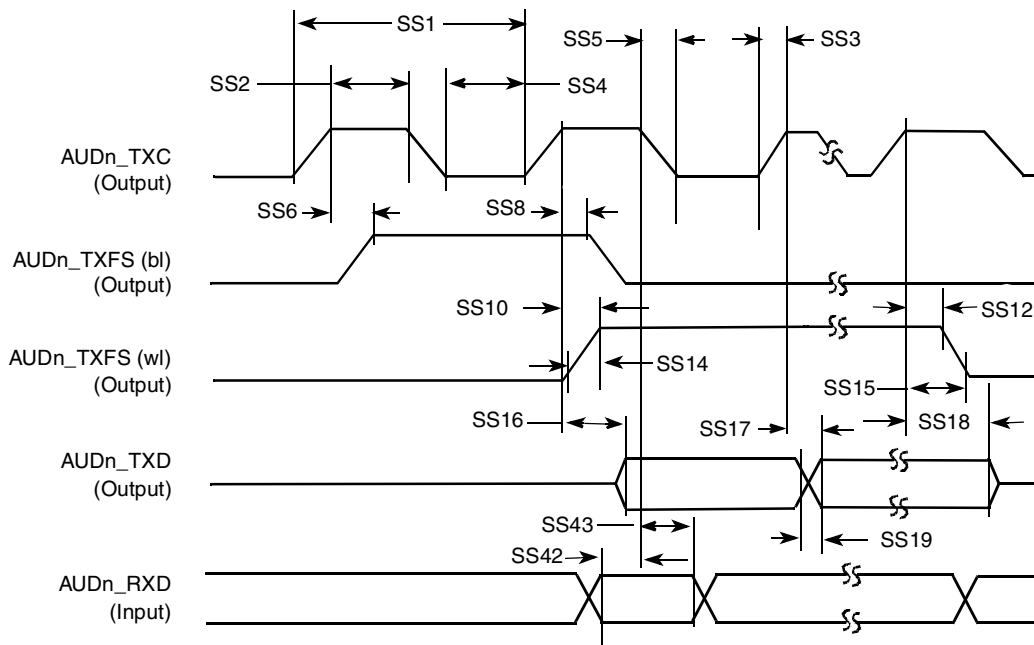

Note: SRXD Input in Synchronous mode only

Figure 78. SSI Transmitter with Internal Clock Timing Diagram

Table 79. SSI Transmitter Timing with Internal Clock

ID	Parameter	Min.	Max.	Unit
Internal Clock Operation				
SS1	(Tx/Rx) CK clock period	81.4	—	ns
SS2	(Tx/Rx) CK clock high period	36.0	—	ns
SS3	(Tx/Rx) CK clock rise time	—	6.0	ns
SS4	(Tx/Rx) CK clock low period	36.0	—	ns
SS5	(Tx/Rx) CK clock fall time	—	6.0	ns
SS6	(Tx) CK high to FS (bl) high	—	15.0	ns
SS8	(Tx) CK high to FS (bl) low	—	15.0	ns
SS10	(Tx) CK high to FS (wl) high	—	15.0	ns
SS12	(Tx) CK high to FS (wl) low	—	15.0	ns
SS14	(Tx/Rx) internal FS rise time	—	6.0	ns
SS15	(Tx/Rx) internal FS fall time	—	6.0	ns
SS16	(Tx) CK high to STXD valid from high impedance	—	15.0	ns
SS17	(Tx) CK high to STXD high/low	—	15.0	ns
SS18	(Tx) CK high to STXD high impedance	—	15.0	ns
SS19	STXD rise/fall time	—	6.0	ns
Synchronous Internal Clock Operation				
SS42	SRXD setup before (Tx) CK falling	10.0	—	ns
SS43	SRXD hold after (Tx) CK falling	0.0	—	ns
SS52	Loading	—	25.0	pf

Note:

- All the timings for the SSI are given for a non-inverted serial clock polarity (TSCKP/RSCCKP = 0) and a non-inverted frame sync (TFSI/RFSI = 0). If the polarity of the clock and/or the frame sync have been inverted, all the timing remains valid by inverting the clock signal STCK/SRCK and/or the frame sync STFS/SRFS shown in the tables and in the figures.
- All timings are on pads when SSI is being used for a data transfer.
- "Tx" and "Rx" refer, respectively, to the transmit and receive sections of the SSI.
- For internal frame sync operation using external clock, the FS timing is the same as that of Tx data (for example, during AC97 mode of operation).

3.7.17.2 SSI Receiver Timing with Internal Clock

Figure 79 shows the timing for the SSI receiver with internal clock. Table 80 describes the timing parameters (SS1–SS51) shown in the figure.

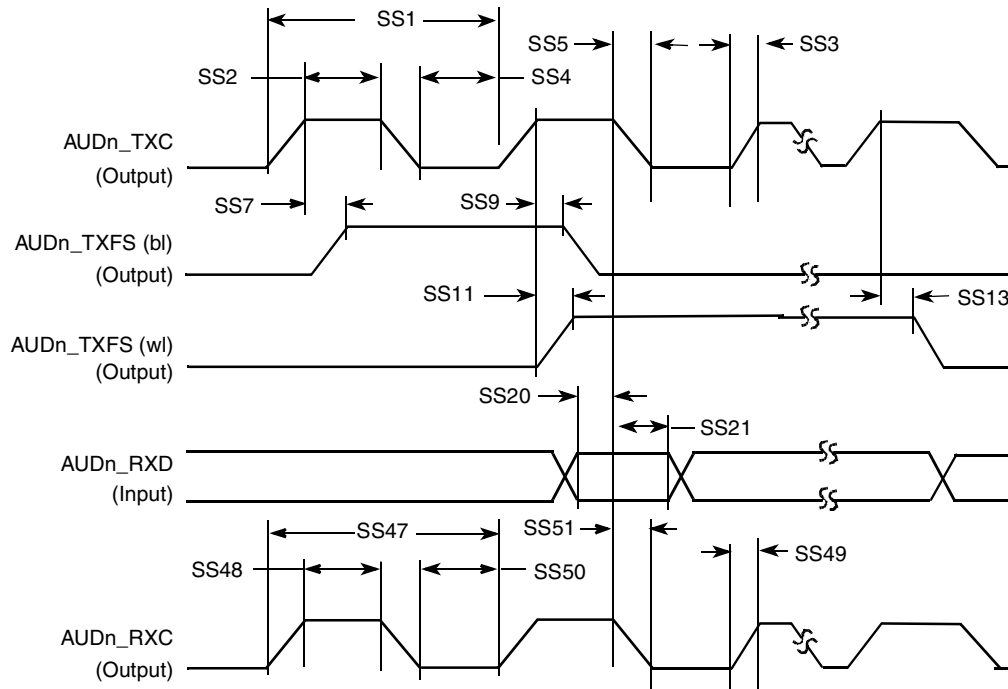

Figure 79. SSI Receiver Internal Clock Timing Diagram

Table 80. SSI Receiver Timing with Internal Clock

ID	Parameter	Min.	Max.	Unit
Internal Clock Operation				
SS1	(Tx/Rx) CK clock period	81.4	—	ns
SS2	(Tx/Rx) CK clock high period	36.0	—	ns
SS3	(Tx/Rx) CK clock rise time	—	6.0	ns
SS4	(Tx/Rx) CK clock low period	36.0	—	ns
SS5	(Tx/Rx) CK clock fall time	—	6.0	ns
SS7	(Rx) CK high to FS (bl) high	—	15.0	ns
SS9	(Rx) CK high to FS (bl) low	—	15.0	ns
SS11	(Rx) CK high to FS (wl) high	—	15.0	ns
SS13	(Rx) CK high to FS (wl) low	—	15.0	ns
SS20	SRXD setup time before (Rx) CK low	10.0	—	ns
SS21	SRXD hold time after (Rx) CK low	0.0	—	ns
Oversampling Clock Operation				
SS47	Oversampling clock period	15.04	—	ns

Table 80. SSI Receiver Timing with Internal Clock (continued)

ID	Parameter	Min.	Max.	Unit
SS48	Oversampling clock high period	6.0	—	ns
SS49	Oversampling clock rise time	—	3.0	ns
SS50	Oversampling clock low period	6.0	—	ns
SS51	Oversampling clock fall time	—	3.0	ns

Note:

- All the timings for the SSI are given for a non-inverted serial clock polarity (TSCKP/RSCKP = 0) and a non-inverted frame sync (TFSI/RFSI = 0). If the polarity of the clock and/or the frame sync have been inverted, all the timing remains valid by inverting the clock signal STCK/SRCK and/or the frame sync STFS/SRFS shown in the tables and in the figures.
- All timings are on pads when SSI is being used for a data transfer.
- "Tx" and "Rx" refer to the transmit and receive sections of the SSI.
- For internal frame sync operation using external clock, the FS timing is the same as that of Tx Data (for example, during AC97 mode of operation).

3.7.17.3 SSI Transmitter Timing with External Clock

Figure 80 shows the timing for the SSI transmitter with external clock. Table 81 describes the timing parameters (SS22-SS46) shown in the figure.

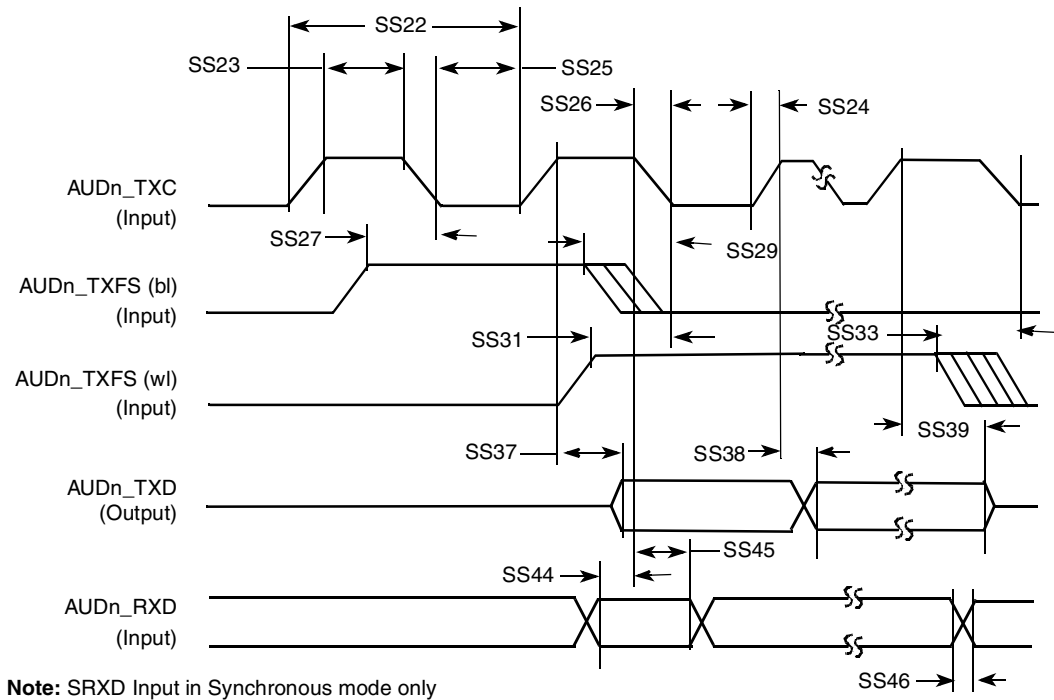

Figure 80. SSI Transmitter with External Clock Timing Diagram

Table 81. SSI Transmitter Timing with External Clock

ID	Parameter	Min.	Max.	Unit
External Clock Operation				
SS22	(Tx/Rx) CK clock period	81.4	—	ns
SS23	(Tx/Rx) CK clock high period	36.0	—	ns
SS24	(Tx/Rx) CK clock rise time	—	6.0	ns
SS25	(Tx/Rx) CK clock low period	36.0	—	ns
SS26	(Tx/Rx) CK clock fall time	—	6.0	ns
SS27	FS (bl) low/ high setup before (Tx) CK falling	-10.0	15.0	ns
SS29	FS (bl) low/ high setup before (Tx) CK falling	10.0	—	ns
SS31	FS (wl) low/ high setup before (Tx) CK falling	-10.0	15.0	ns
SS33	FS (wl) low/ high setup before (Tx) CK falling	10.0	—	ns
SS37	(Tx) CK high to STXD valid from high impedance	—	15.0	ns
SS38	(Tx) CK high to STXD high/low	—	15.0	ns
SS39	(Tx) CK high to STXD high impedance	—	15.0	ns
Synchronous External Clock Operation				
SS44	SRXD setup before (Tx) CK falling	10.0	—	ns
SS45	SRXD hold after (Tx) CK falling	2.0	—	ns
SS46	SRXD rise/fall time	—	6.0	ns

Note:

- All the timings for the SSI are given for a non-inverted serial clock polarity (TSCKP/RSCKP = 0) and a non-inverted frame sync (TFSI/RFSI = 0). If the polarity of the clock and/or the frame sync have been inverted, all the timing remains valid by inverting the clock signal STCK/SRCK and/or the frame sync STFS/SRFS shown in the tables figures.
- All timings are on pads when SSI is being used for data transfer.
- "Tx" and "Rx" refer, respectively, to the transmit and receive sections of the SSI.
- For internal frame sync operation using external clock, the FS timing is the same as that of Tx data (for example, during AC97 mode of operation).

3.7.17.4 SSI Receiver Timing with External Clock

Figure 81 shows the timing for SSI receiver with external clock. Table 82 describes the timing parameters (SS22–SS41) used in the figure.

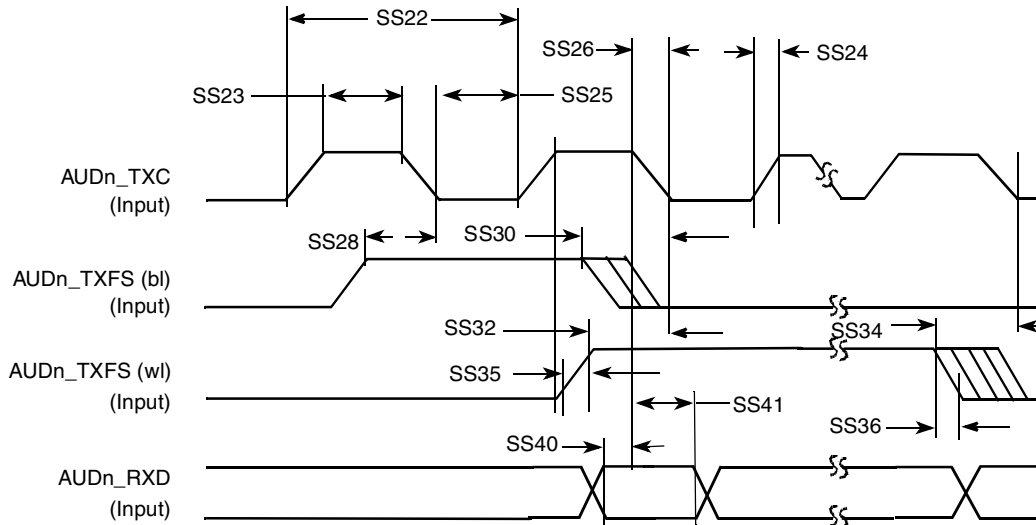

Figure 81. SSI Receiver with External Clock Timing Diagram

Table 82. SSI Receiver Timing with External Clock

ID	Parameter	Min.	Max.	Unit
External Clock Operation				
SS22	(Tx/Rx) CK clock period	81.4	—	ns
SS23	(Tx/Rx) CK clock high period	36.0	—	ns
SS24	(Tx/Rx) CK clock rise time	—	6.0	ns
SS25	(Tx/Rx) CK clock low period	36.0	—	ns
SS26	(Tx/Rx) CK clock fall time	—	6.0	ns
SS28	FS (bl) low/high setup before (Tx) CK falling	–10.0	15.0	ns
SS30	FS (bl) low/high setup before (Tx) CK falling	10.0	—	ns
SS32	FS (wl) low/high setup before (Tx) CK falling	–10.0	15.0	ns
SS34	FS (wl) low/high setup before (Tx) CK falling	10.0	—	ns
SS35	(Tx/Rx) External FS rise time	—	6.0	ns
SS36	(Tx/Rx) External FS fall time	—	6.0	ns
SS40	SRXD setup time before (Rx) CK low	10.0	—	ns
SS41	SRXD hold time after (Rx) CK low	2.0	—	ns

Note:

- All the timings for the SSI are given for a non-inverted serial clock polarity (TSCKP/RSCKP = 0) and a non-inverted frame sync (TFSI/RFSI = 0). If the polarity of the clock and/or the frame sync have been inverted, all the timing remains valid by inverting the clock signal STCK/SRCK and/or the frame sync STFS/SRFS shown in the tables and in the figures.
- All timings are on pads when SSI is being used for data transfer.

- "Tx" and "Rx" refer, respectively, to the transmit and receive sections of the SSI.
- For internal frame sync operation using external clock, the FS timing is the same as that of Tx data (for example, during AC97 mode of operation).

3.7.18 Touchscreen ADC Electrical Specifications and Timing

This section describes the electrical specifications, operation modes, and timing of the touchscreen ADC.

3.7.18.1 ADC Electrical Specifications

Table 83 shows the electrical specifications for the touchscreen ADC.

Table 83. Touchscreen ADC Electrical Specifications

Parameter	Conditions	Min.	Typ.	Max.	Unit
ADC					
Input sampling capacitance (C_S)	No pin/pad capacitance included	—	2	—	pF
Resolution	—	12			bits
Analog Bias					
Resistance value between <i>ref</i> and <i>agndref</i>	—	—	1.6	—	k Ω
Timing Characteristics					
Sampling rate (fs)	—	—	—	125	kHz
Internal ADC/TSC clock frequency	—	—	—	1.75	MHz
Multiplexed inputs	—	8			—
Data latency	—	12.5			clk cycles
Power-up time ¹	—	14			clk cycles
clk falling edge to sampling delay (tsd)	—	2	5	8	ns
soc input setup time before clk rising edge (tsocst)	—	0.5	1	3	ns
soc input hold time after clk rising edge (tsochld)	—	2	3	6	ns
eoc delay after clk rise edge (teoc)	With a 250fF load	2	7	10	ns
Valid data out delay after eoc rise edge (tdata)	With a 250fF load	5	8	13	ns

Table 83. Touchscreen ADC Electrical Specifications (continued)

Parameter	Conditions	Min.	Typ.	Max.	Unit
Power Supply Requirements					
Current consumption ² NVCC_ADC QV _{DD}	—	—	—	2.1 0.5	mA mA
Power-down current NVCC_ADC QV _{DD}	—	—	—	1 10	μA μA
Touchscreen Interface					
Expected plate resistance	—	100	—	1500	Ω
Switch drivers on resistance	GND and VDD switches	—	—	10	Ω
Conversion Characteristics³					
DNL ⁴	fin = 1 kHz	—	+/-0.75	—	LSB
INL ⁴	fin = 1 kHz	—	+/-2.0	—	LSB
Gain + Offset Error	—	—	—	+/-2	%FS

¹ This comprises only the required initial dummy conversion cycle. Additional power-up time depends on the *enadc*, *reset* and *soc* signals applied to the touchscreen controller.

² This value only includes the ADC and the driver switches, but it does not take into account the current consumption in the touchscreen plate. For example, if the plate resistance is 100 W, the total current consumption is about 33 mA.

³ At avdd = 3.3 V, dvdd = 1.2 V, Tjunction = 50 °C, fclk = 1.75 MHz, any process corner, unless otherwise noted.

⁴ Value measured with a -0.5 dBFS sinusoidal input signal and computed with the code density test.

3.7.18.2 ADC Timing Diagrams

Figure 82 represents the synchronization between the signals *clk*, *soc*, *eoc*, and the output bits in the usage of the internal ADC. After a conversion cycle *eoc* is asserted, a new conversion begins only when the

assertion of *soc* is detected. Thus, if the *soc* signal is continuously asserted, the ADC undergoes successive conversion cycles and achieves the maximum sampling rate. If *soc* is negated, no conversion is initiated.

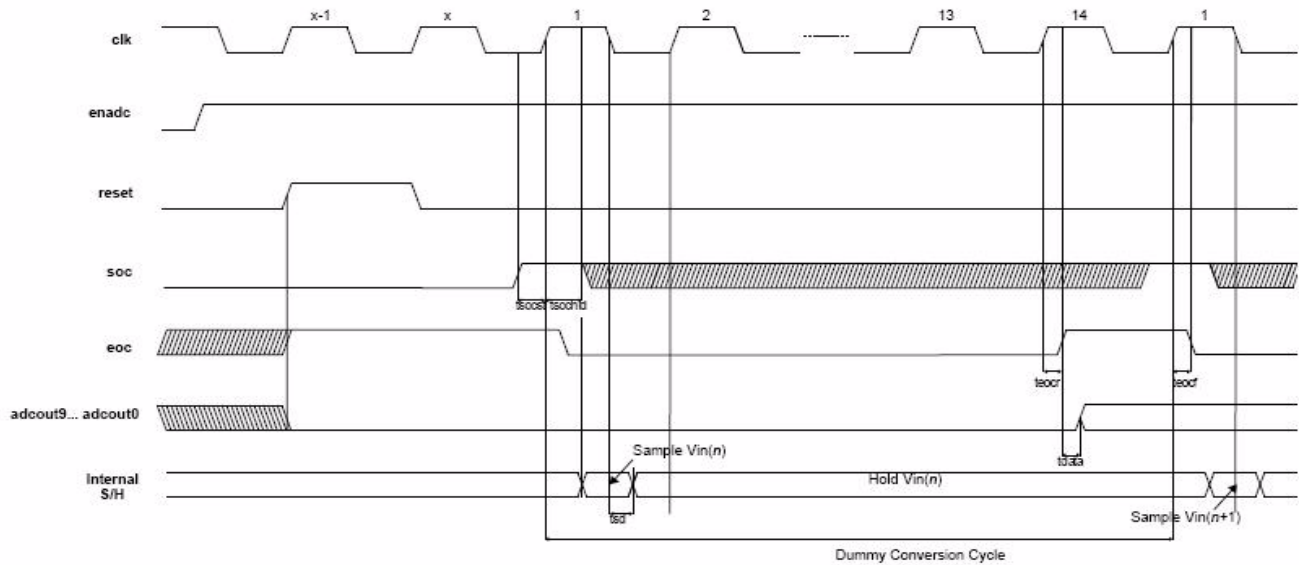

Figure 82. Start-up Sequence

The output data can be read from *adcout11...adcout0*, and is available *tdata* nanoseconds after the rising edge of *eoc*. The *reset* signal and the digital signals controlling the analog switches (*y_{psw}*, *x_{psw}*, *y_{nsw}*, *x_{nsw}*) are totally asynchronous.

The following conditions are necessary to guarantee the correct operation of the ADC:

- The input multiplexer selection (*selin11...selin0*) is stable during both the last clock cycle (14th) and the first clock cycle (1st). The best way to guarantee this is to make the input multiplexer selection during clock cycles 2 to 13.
- The references are stable during clock cycle 1 to 13. The best way to guarantee this is to make the reference multiplexer selection (*selrefp* and *selrefn*) before issuing an *soc* pulse and changing it only after an *eoc* pulse has been acquired, during the last clock cycle (14).

Figure 83 shows the timing for ADC normal operation.

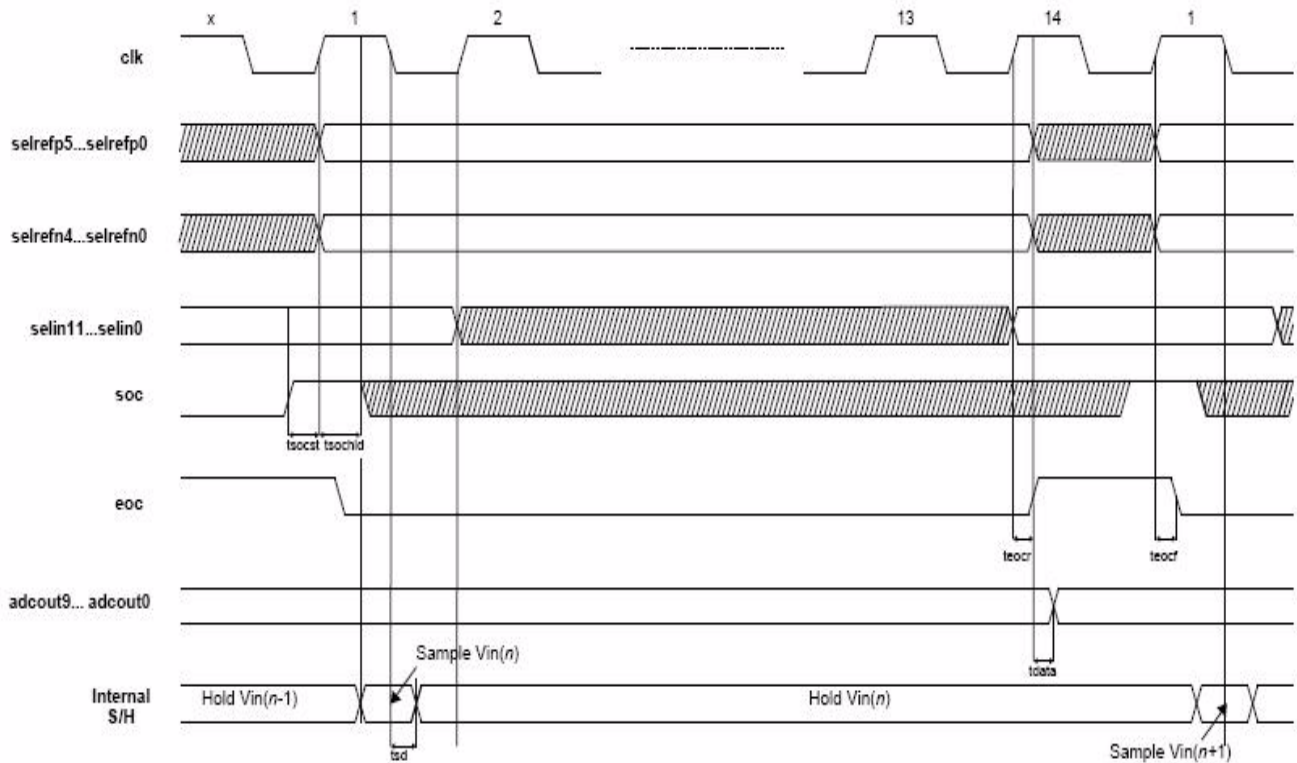

Figure 83. Timing for ADC Normal Operation

When the ADC is used so that the idle clock cycles occur between conversions (due to the negation of *soc*), the *selin* inputs must be stable at least 1 clock cycle before the clock's rising edge where the *soc* signal is latched. Also, *selrefp* and *selrefn* must be stable by the time the *soc* signal is latched. These conditions are met if *enadc*=1 and *reset*=0 throughout ADC operation, including the idle cycles. If the conditions are not met, or if power is lost during ADC operation, then a new start-up sequence is required for ADC to become operational again.

Figure 84 represents the usage of the ADC with idle cycles between conversions. This diagram is valid for any value of N equal or greater than 1.

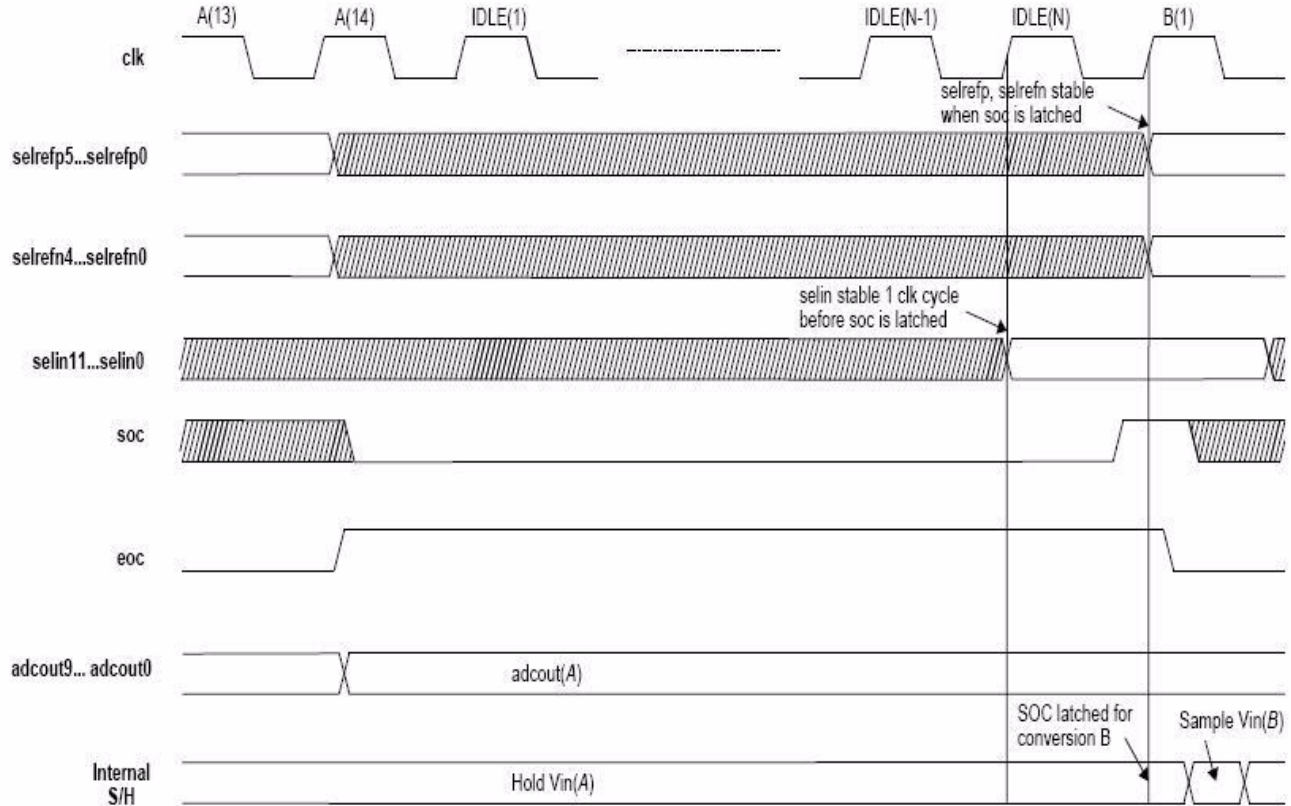

Figure 84. ADC Usage with Idle Cycles Between Conversions

3.7.19 UART Timing

This section describes the timing of the UART module in serial and parallel mode.

3.7.19.1 UART RS-232 Serial Mode Timing

3.7.19.1.1 UART Transmit Timing in RS-232 Serial Mode

Figure 85 shows the UART transmit timing in RS-232 serial mode, showing only 8 data bits and 1 stop bit. Table 84 describes the timing parameter (UA1) shown in the figure.

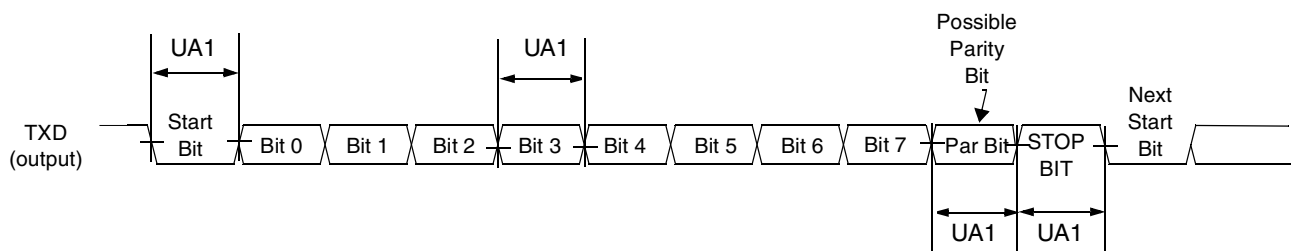

Figure 85. UART RS-232 Serial Mode Transmit Timing Diagram

Table 84. UART RS-232 Serial Mode Transmit Timing Parameters

ID	Parameter	Symbol	Min.	Max.	Units
UA1	Transmit Bit Time	t_{Tbit}	$1/F_{baud_rate}^1 - T_{ref_clk}^2$	$1/F_{baud_rate} + T_{ref_clk}$	—

¹ F_{baud_rate} : Baud rate frequency. The maximum baud rate the UART can support is $(ipg_perclk \text{ frequency})/16$.

² T_{ref_clk} : The period of UART reference clock ref_clk (ipg_perclk after RFDIV divider).

3.7.19.1.2 UART Receive Timing in RS-232 Serial Mode

Figure 86 shows the UART receive timing in RS-232 serial mode, showing only 8 data bits and 1 stop bit. Table 85 describes the timing parameter (UA2) shown in the figure.

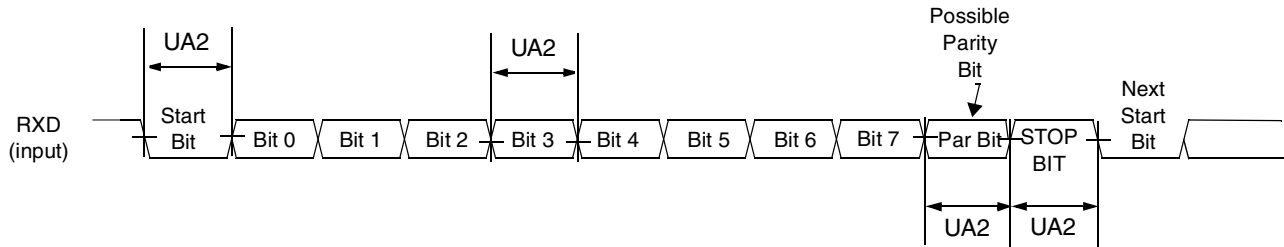

Figure 86. UART RS-232 Serial Mode Receive Timing Diagram

Table 85. UART RS-232 Serial Mode Receive Timing Parameters

ID	Parameter	Symbol	Min.	Max.	Units
UA2	Receive bit time ¹	t_{Rbit}	$1/F_{baud_rate}^2 - 1/(16 \times F_{baud_rate})$	$1/F_{baud_rate} + 1/(16 \times F_{baud_rate})$	—

¹ Note: The UART receiver can tolerate $1/(16 \times F_{baud_rate})$ tolerance in each bit. But accumulation tolerance in one frame must not exceed $3/(16 \times F_{baud_rate})$.

² F_{baud_rate} : Baud rate frequency. The maximum baud rate the UART can support is $(ipg_perclk \text{ frequency})/16$.

3.7.19.2 UART Infrared (IrDA) Mode Timing

The following subsections describe the UART transmit and receive timing in IrDA mode.

3.7.19.2.3 UART IrDA Mode Transmit Timing

Figure 87 depicts the UART transmit timing in IrDA mode, showing only 8 data bits and 1 stop bit. Table 86 describes the timing parameters (UA3–UA4) shown in the figure.

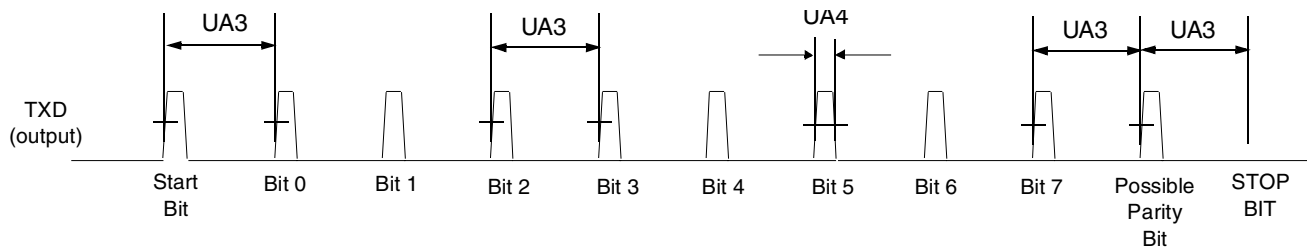

Figure 87. UART IrDA Mode Transmit Timing Diagram

Table 86. UART IrDA Mode Transmit Timing Parameters

ID	Parameter	Symbol	Min.	Max.	Units
UA3	Transmit bit time in IrDA mode	t_{TIRbit}	$1/F_{baud_rate}^1 - T_{ref_clk}^2$	$1/F_{baud_rate} + T_{ref_clk}$	—
UA4	Transmit IR pulse duration	$t_{TIRpulse}$	$(3/16) \times (1/F_{baud_rate}) - T_{ref_clk}$	$(3/16) \times (1/F_{baud_rate}) + T_{ref_clk}$	—

¹ F_{baud_rate} : Baud rate frequency. The maximum baud rate the UART can support is $(ipg_perclk \text{ frequency})/16$.

² T_{ref_clk} : The period of UART reference clock ref_clk (ipg_perclk after RFDIV divider).

3.7.19.2.4 UART IrDA Mode Receive Timing

Figure 88 shows the UART receive timing for IrDA mode, for a format of 8 data bits and 1 stop bit. Table 87 describes the timing parameters (UA5–UA6) shown in the figure.

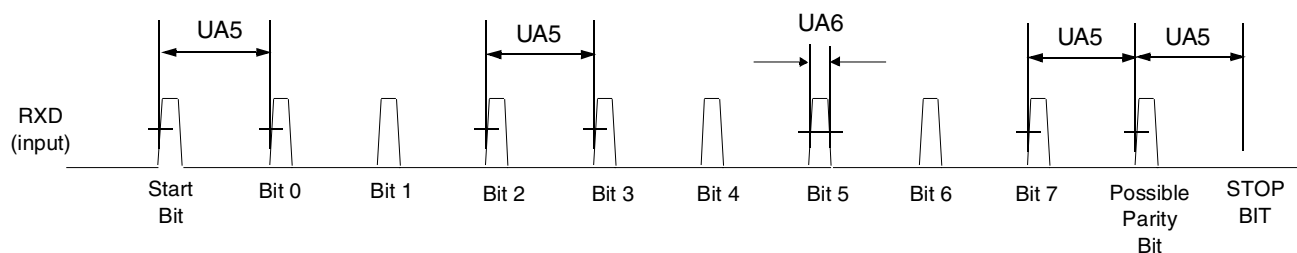

Figure 88. UART IrDA Mode Receive Timing Diagram

Table 87. UART IrDA Mode Receive Timing Parameters

ID	Parameter	Symbol	Min.	Max.	Units
UA5	Receive bit time ¹ in IrDA mode	t_{RIRbit}	$1/F_{baud_rate}^2 - 1/(16 \times F_{baud_rate})$	$1/F_{baud_rate} + 1/(16 \times F_{baud_rate})$	—
UA6	Receive IR pulse duration	$t_{RIRpulse}$	1.41 us	$(5/16) \times (1/F_{baud_rate})$	—

¹ Note: The UART receiver can tolerate $1/(16 \times F_{baud_rate})$ tolerance in each bit. But accumulation tolerance in one frame must not exceed $3/(16 \times F_{baud_rate})$.

² F_{baud_rate} : Baud rate frequency. The maximum baud rate the UART can support is $(ipg_perclk \text{ frequency})/16$.

3.7.20 USBOTG Timing

This section describes timing for the USB OTG port and host ports. Both serial and parallel interfaces are described.

3.7.20.1 USB Serial Interface Timing

The USB serial transceiver is configurable to four modes supporting four different serial interfaces:

- DAT_SE0 bidirectional, 3-wire mode
- DAT_SE0 unidirectional, 6-wire mode
- VP_VM bidirectional, 4-wire mode
- VP_VM unidirectional, 6-wire mode

The following subsections describe the timings for these four modes.

3.7.20.1.1 DAT_SE0 Bidirectional Mode Timing

Table 88 defines the DAT_SE0 bidirectional mode signals.

Table 88. Signal Definitions—DAT_SE0 Bidirectional Mode

Name	Direction	Signal Description
USB_TXOE_B	Out	Transmit enable, active low
USB_DAT_VP	Out In	Tx data when USB_TXOE_B is low Differential Rx data when USB_TXOE_B is high
USB_SE0_VM	Out In	SE0 drive when USB_TXOE_B is low SE0 Rx indicator when USB_TXOE_B is high

Figure 89 shows the USB transmit waveform in DAT_SE0 bidirectional mode diagram.

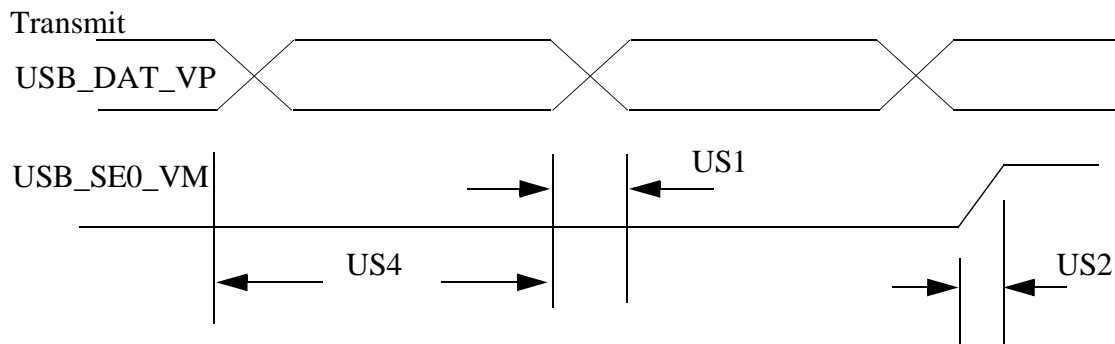

Figure 89. USB Transmit Waveform in DAT_SE0 Bidirectional Mode

Figure 90 shows the USB receive waveform in DAT_SE0 bidirectional mode diagram.

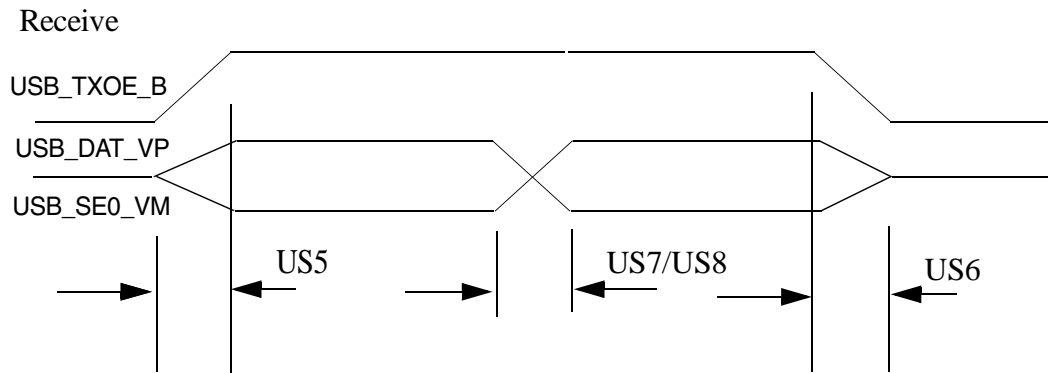

Figure 90. USB Receive Waveform in DAT_SE0 Bidirectional Mode

Table 89 shows the OTG port timing specification in DAT_SE0 bidirectional mode.

Table 89. OTG Port Timing Specification in DAT_SE0 Bidirectional Mode

No.	Parameter	Signal Name	Direction	Min.	Max.	Unit	Conditions/ Reference Signal
US1	Tx rise/fall time	USB_DAT_VP	Out	—	5.0	ns	50 pF
US2	Tx rise/fall time	USB_SE0_VM	Out	—	5.0	ns	50 pF
US3	Tx rise/fall time	USB_TXOE_B	Out	—	5.0	ns	50 pF
US4	Tx duty cycle	USB_DAT_VP	Out	49.0	51.0	%	—
US5	Enable Delay	USB_DAT_VP USB_SE0_VM	In	—	8.0	ns	USB_TXOE_B
US6	Disable Delay	USB_DAT_VP USB_SE0_VM	In	—	10.0	ns	USB_TXOE_B
US7	Rx rise/fall time	USB_DAT_VP	In	—	3.0	ns	35 pF
US8	Rx rise/fall time	USB_SE0_VM	In	—	3.0	ns	35 pF

3.7.20.1.2 DAT_SE0 Unidirectional Mode Timing

Table 90 defines the DAT_SE0 unidirectional mode signals.

Table 90. Signal Definitions—DAT_SE0 Unidirectional Mode

Name	Direction	Signal Description
USB_TXOE_B	Out	Transmit enable, active low
USB_DAT_VP	Out	Tx data when USB_TXOE_B is low
USB_SE0_VM	Out	SE0 drive when USB_TXOE_B is low
USB_VP1	In	Buffered data on DP when USB_TXOE_B is high
USB_VM1	In	Buffered data on DM when USB_TXOE_B is high
USB_RCV	In	Differential Rx data when USB_TXOE_B is high

Figure 91 shows the USB transmit waveform in DAT_SE0 unidirectional mode diagram.

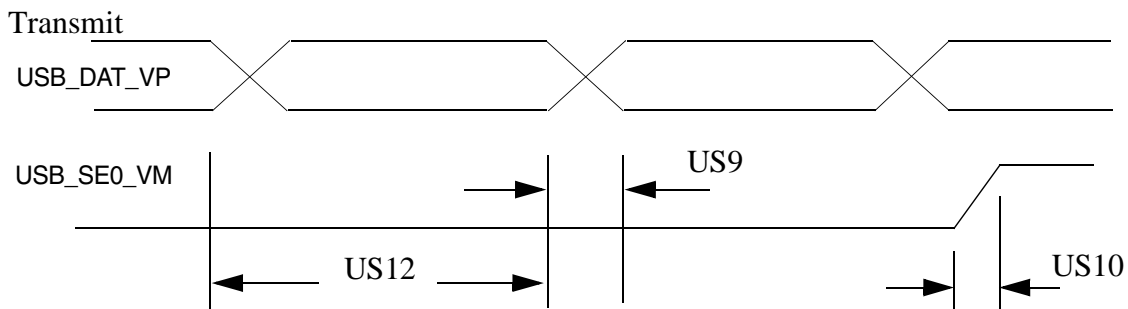

Figure 91. USB Transmit Waveform in DAT_SE0 Unidirectional Mode

Figure 92 shows the USB receive waveform in DAT_SE0 unidirectional mode diagram.

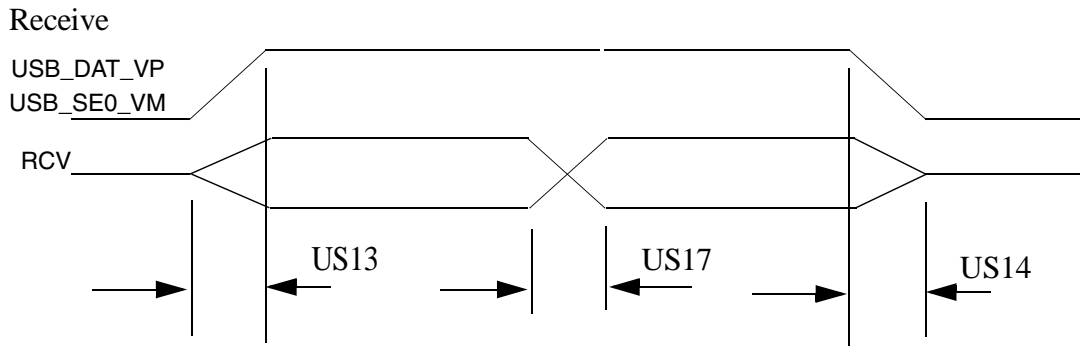

Figure 92. USB Receive Waveform in DAT_SE0 Unidirectional Mode

Table 91 shows the USB port timing specification in DAT_SE0 unidirectional mode.

Table 91. USB Port Timing Specification in DAT_SE0 Unidirectional Mode

No.	Parameter	Signal Name	Signal Source	Min.	Max.	Unit	Condition/Reference Signal
US9	Tx rise/fall time	USB_DAT_VP	Out	—	5.0	ns	50 pF
US10	Tx rise/fall time	USB_SE0_VM	Out	—	5.0	ns	50 pF
US11	Tx rise/fall time	USB_TXOE_B	Out	—	5.0	ns	50 pF
US12	Tx duty cycle	USB_DAT_VP	Out	49.0	51.0	%	—
US13	Enable Delay	USB_DAT_VP USB_SE0_VM	In	—	8.0	ns	USB_TXOE_B
US14	Disable Delay	USB_DAT_VP USB_SE0_VM	In	—	10.0	ns	USB_TXOE_B
US15	Rx rise/fall time	USB_VP1	In	—	3.0	ns	35 pF
US16	Rx rise/fall time	USB_VM1	In	—	3.0	ns	35 pF
US17	Rx rise/fall time	USB_RCV	In	—	3.0	ns	35 pF

3.7.20.1.3 VP_VM Bidirectional Mode Timing

Table 92 defines the VP_VM bidirectional mode signals.

Table 92. Signal Definitions—VP_VM Bidirectional Mode

Name	Direction	Signal Description
USB_TXOE_B	Out	• Transmit enable, active low
USB_DAT_VP	Out (Tx) In (Rx)	• Tx VP data when USB_TXOE_B is low • Rx VP data when USB_TXOE_B is high
USB_SE0_VM	Out (Tx) In (Rx)	• Tx VM data when USB_TXOE_B low • Rx VM data when USB_TXOE_B high
USB_RCV	In	• Differential Rx data

Figure 93 shows the USB transmit waveform in VP_VM bidirectional mode diagram.

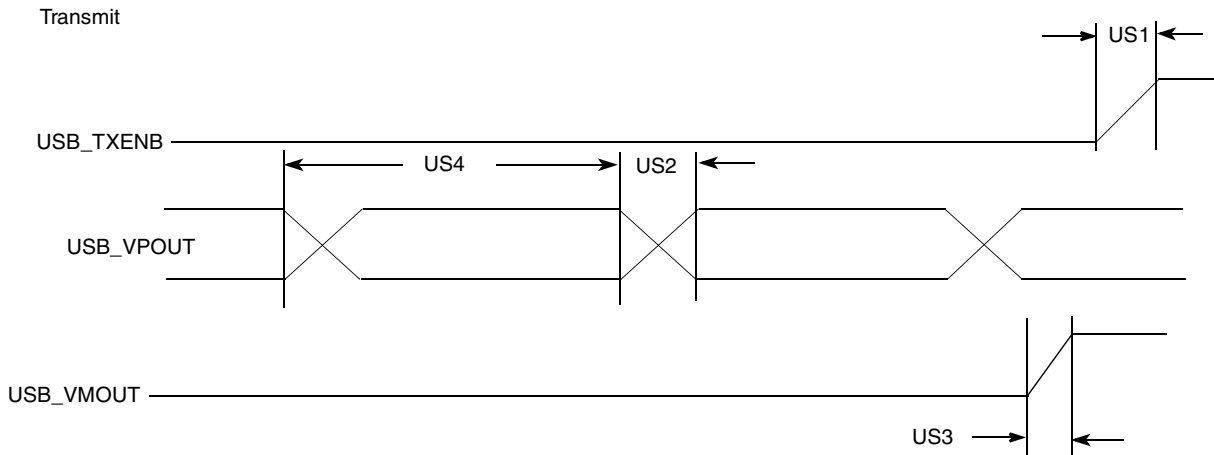

Figure 93. USB Transmit Waveform in VP_VM Bidirectional Mode

Figure 94 shows the USB receive waveform in VP_VM bidirectional mode diagram.

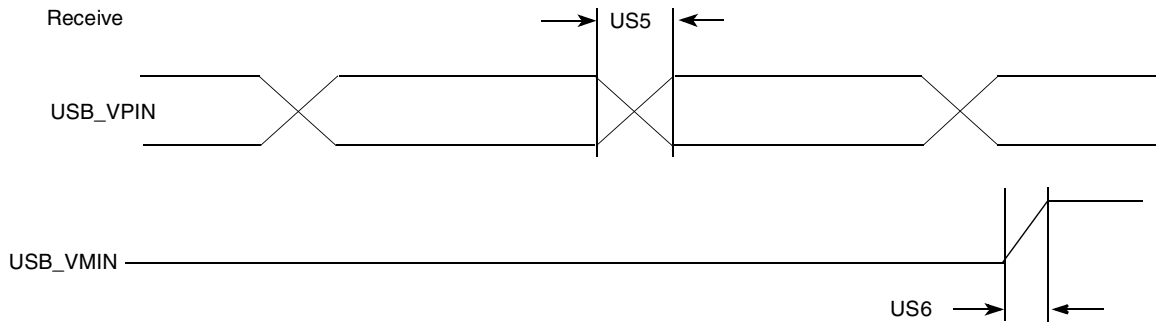

Figure 94. USB Receive Waveform in VP_VM Bidirectional Mode

Table 93 shows the USB port timing specification in VP_VM bidirectional mode.

Table 93. USB Port Timing Specifications in VP_VM Bidirectional Mode

No.	Parameter	Signal Name	Direction	Min.	Max.	Unit	Condition/ Reference Signal
US18	Tx rise/fall time	USB_DAT_VP	Out	—	5.0	ns	50 pF
US19	Tx rise/fall time	USB_SE0_VM	Out	—	5.0	ns	50 pF
US20	Tx rise/fall time	USB_TXOE_B	Out	—	5.0	ns	50 pF
US21	Tx duty cycle	USB_DAT_VP	Out	49.0	51.0	%	—
US22	Tx high overlap	USB_SE0_VM	Out	0.0	—	ns	USB_DAT_VP
US23	Tx low overlap	USB_SE0_VM	Out	—	0.0	ns	USB_DAT_VP
US24	Enable delay	USB_DAT_VP USB_SE0_VM	In	—	8.0	ns	USB_TXOE_B
US25	Disable delay	USB_DAT_VP USB_SE0_VM	In	—	10.0	ns	USB_TXOE_B

Table 93. USB Port Timing Specifications in VP_VM Bidirectional Mode (continued)

No.	Parameter	Signal Name	Direction	Min.	Max.	Unit	Condition/ Reference Signal
US26	Rx rise/fall time	USB_DAT_VP	In	—	3.0	ns	35 pF
US27	Rx rise/fall time	USB_SE0_VM	In	—	3.0	ns	35 pF
US28	Rx skew	USB_DAT_VP	Out	-4.0	+4.0	ns	USB_SE0_VM
US29	Rx skew	USB_RCV	Out	-6.0	+2.0	ns	USB_DAT_VP

3.7.20.1.4 VP_VM Unidirectional Mode Timing

Table 94 defines the signals for USB in VP_VM unidirectional mode.

Table 94. Signal Definitions for USB VP_VM Unidirectional Mode

Name	Direction	Signal Description
USB_TXOE_B	Out	Transmit enable, active low
USB_DAT_VP	Out	Tx VP data when USB_TXOE_B is low
USB_SE0_VM	Out	Tx VM data when USB_TXOE_B is low
USB_VP1	In	Rx VP data when USB_TXOE_B is high
USB_VM1	In	Rx VM data when USB_TXOE_B is high
USB_RCV	In	Differential Rx data

Figure 95 shows the USB transmit waveform in VP_VM unidirectional mode diagram.

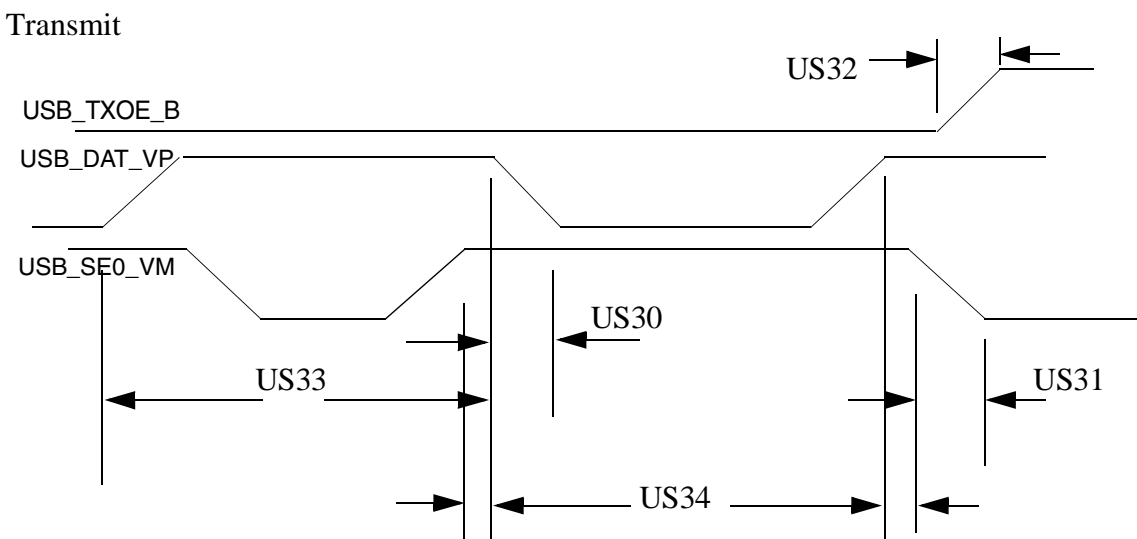

Figure 95. USB Transmit Waveform in VP_VM Unidirectional Mode

Figure 96 shows the USB receive waveform in VP_VM unidirectional mode diagram.

Receive

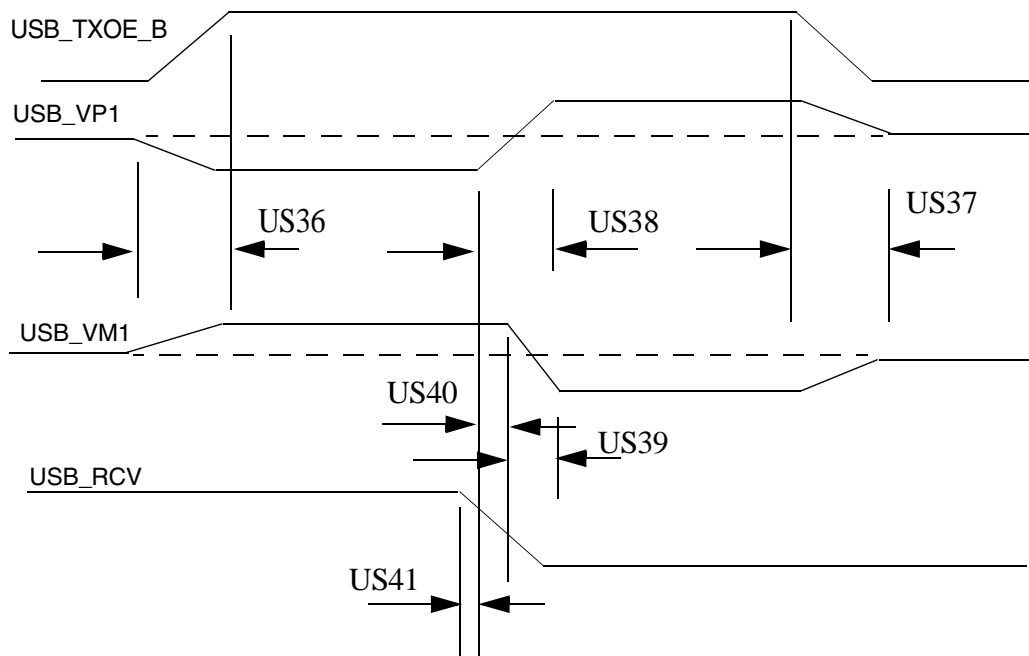

Figure 96. USB Receive Waveform in VP_VM Unidirectional Mode

Table 95 shows the timing specifications for USB in VP_VM unidirectional mode.

Table 95. USB Timing Specifications in VP_VM Unidirectional Mode

No.	Parameter	Signal	Direction	Min.	Max.	Unit	Conditions/ Reference Signal
US30	Tx rise/fall time	USB_DAT_VP	Out	—	5.0	ns	50 pF
US31	Tx rise/fall time	USB_SE0_VM	Out	—	5.0	ns	50 pF
US32	Tx rise/fall time	USB_TXOE_B	Out	—	5.0	ns	50 pF
US33	Tx duty cycle	USB_DAT_VP	Out	49.0	51.0	%	—
US34	Tx high overlap	USB_SE0_VM	Out	0.0	—	ns	USB_DAT_VP
US35	Tx low overlap	USB_SE0_VM	Out	—	0.0	ns	USB_DAT_VP
US36	Enable delay	USB_DAT_VP USB_SE0_VM	In	—	8.0	ns	USB_TXOE_B
US37	Disable delay	USB_DAT_VP USB_SE0_VM	In	—	10.0	ns	USB_TXOE_B
US38	Rx rise/fall time	USB_VP1	In	—	3.0	ns	35 pF
US39	Rx rise/fall time	USB_VM1	In	—	3.0	ns	35 pF
US40	Rx skew	USB_VP1	Out	-4.0	+4.0	ns	USB_SE0_VM
US41	Rx skew	USB_RCV	Out	-6.0	+2.0	ns	USB_DAT_VP

3.7.20.2 USB Parallel Interface Timing

Table 96 defines the USB parallel interface signals.

Table 96. Signal Definitions for USB Parallel Interface

Name	Direction	Signal Description
USB_Clk	In	Interface clock—All interface signals are synchronous to USB_Clk
USB_Data[7:0]	I/O	Bidirectional data bus, driven low by the link during idle—Bus ownership is determined by the direction
USB_Dir	In	Direction—Control the direction of the data bus
USB_Stp	Out	Stop—The link asserts this signal for one clock cycle to stop the data stream currently on the bus
USB_Nxt	In	Next—The PHY asserts this signal to throttle the data

Figure 97 shows the USB parallel mode transmit/receive waveform. Table 97 describes the timing parameters (USB15–USB17) shown in the figure.

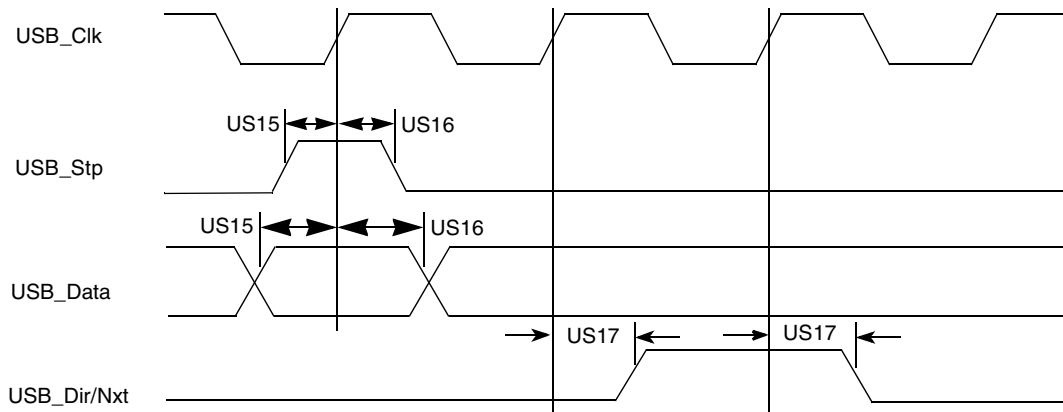

Figure 97. USB Parallel Mode Transmit/Receive Waveform

Table 97. USB Timing Specification in Parallel Mode

ID	Parameter	Min.	Max.	Unit	Conditions/ Reference Signal
US15	Setup time (Dir&Nxt in, Data in)	—	6.0	ns	10 pF
US16	Hold time (Dir&Nxt in, Data in)	—	0.0	ns	10 pF
US17	Output delay time (Stp out, Data out)	—	9.0	ns	10 pF

4 Package Information and Contact Assignment

4.1 400 MAPBGA—Case 17x17 mm, 0.8 mm Pitch

Figure 98 shows the 17×17 mm i.MX25 production package. The following notes apply to Figure 98:

- All dimensions in millimeters.
- Dimensioning and tolerancing per ASME Y14.5M-1994.

- Maximum solder bump diameter measured parallel to datum A.
- Datum A, the seating plane, is determined by the spherical crowns of the solder bumps.
- Parallelism measurement shall exclude any effect of mark on top surface of package.

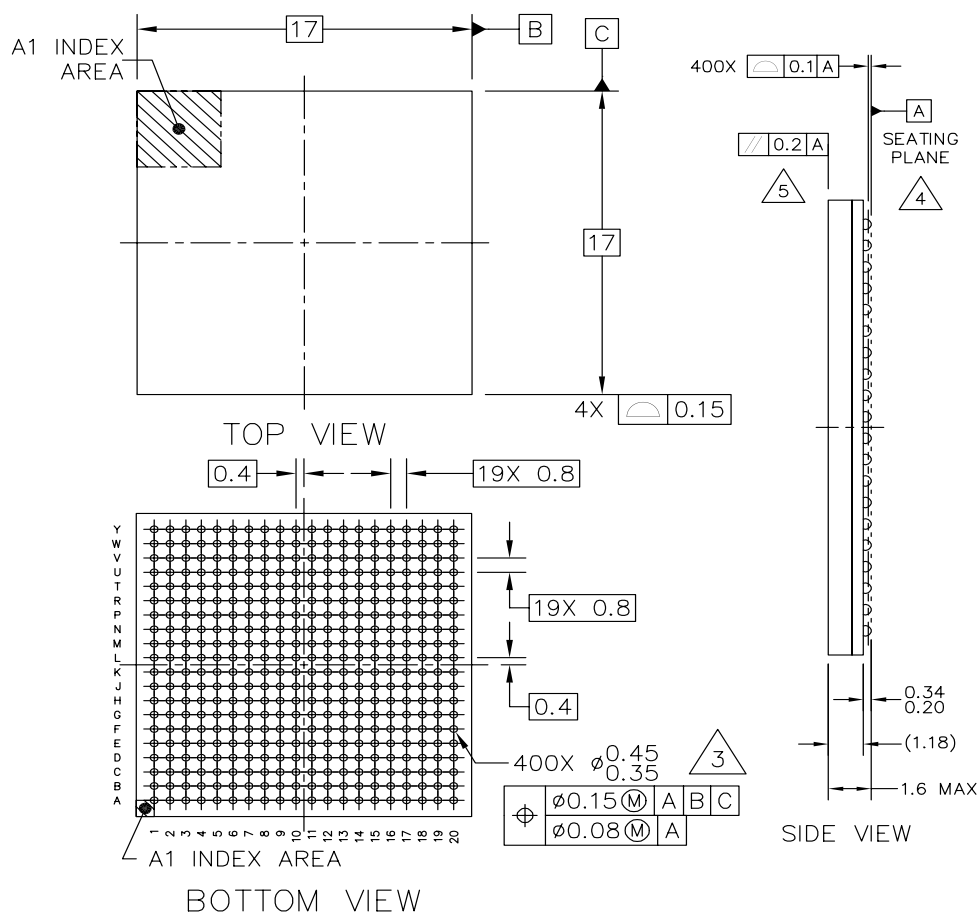

Figure 98. 17x17 i.MX25 Production Package

4.2 Ground, Power, Sense, and Reference Contact Assignments Case 17x17 mm, 0.8 mm Pitch

Table 98 shows the 17x17 mm package ground, power, sense, and reference contact assignments.

Table 98. 17x17 mm Package Ground, Power Sense, and Reference Contact Assignments

Contact Name	Contact Assignment
BATT_VDD	P10
FUSE_VDD	T17
MPLL_GND	U17
MPLL_VDD	U18
NGND_ADC	Y13

Table 98. 17×17 mm Package Ground, Power Sense, and Reference Contact Assignments (continued)

Contact Name	Contact Assignment
NVCC_ADC	W13
NVCC_CRM	N14
NVCC_CSI	J13, J14
NVCC_DRYICE	W11
NVCC_EMI1	G6, G7, G8, G9, H6, H7, H8, J6, J7
NVCC_EMI2	G12, G13, G14, G15, H12, H13, H14
NVCC_JTAG	U10
NVCC_LCDC	P6, P7, R6, R7
NVCC_MISC	N5, N6, N7
NVCC_NFC	L6, L7, L8
NVCC_SDIO	R17
OSC24M_GND	W15
OSC24M_VDD	W16
QGND	A1, A11, A20, B11, C11, D11, E5, E6, E7, E8, E9, E10, E11, E12, E13, E14, E15, E16, F5, F6, F7, F8, F9, F10, F11, F12, F13, F14, F15, F16, G5, G10, G16, H5, H9, H10, H11, H15, H16, J5, J9, J10, J11, J15, J16, K1, K2, K3, K4, K5, K8, K9, K10, K11, K13, K14, K15, L5, L9, L10, L11, L12, L13, L14, L15, M8, M9, M10, M11, M12, M13, M14, M15, N9, N12, N13, N15, N16, P5, P13, P14, P15, P16, R5, R8, R9, R10, R11, R12, R13, R14, R15, R16, T5, T6, T7, T8, T9, T10, T11, T12, T13, T14, T15, T16, Y1, Y20
QVDD	G11, J8, J12, K6, K7, K12, M5, M6, M7, N8, P8, P9
REF	V11
UPLL_GND	M16
UPLL_VDD	L16
USBPHY1_UPLLVD	M17
USBPHY1_UPLLVSS	N17
USBPHY1_VDDA	K16
USBPHY1_VDDA_BIAS	K19
USBPHY1_VSSA	L19
USBPHY1_VSSA_BIAS	J17
USBPHY2_VDD	W18
USBPHY2_VSS	W17

4.3 Signal Contact Assignments—17 x 17 mm, 0.8 mm Pitch

Table 99 lists the 17×17 mm package i.MX25 signal contact assignments.

Table 99. 17×17 mm Package i.MX25 Signal Contact Assignment

Signal Name	Contact Assignment	Signal Name	Contact Assignment	Signal Name	Contact Assignment
A0	A18	NFWE_B	G4	SD1_CMD	K20
A1	B17	NFRE_B	C1	SD1_CLK	M20
A2	C17	NFALE	F4	SD1_DATA0	L20
A3	B18	NFCLE	E4	SD1_DATA1	N20
A4	C20	NFWP_B	H4	SD1_DATA2	M19
A5	A19	NFRB	C2	SD1_DATA3	J20
A6	C19	D15	J2	KPP_ROW0	N4
A7	B19	D14	J1	KPP_ROW1	R1
A8	D18	D13	H2	KPP_ROW2	P3
A9	C18	D12	H3	KPP_ROW3	P2
A10	A2	D11	F1	KPP_COL0	P1
MA10	D16	D10	F2	KPP_COL1	N3
A11	D20	D9	D1	KPP_COL2	N2
A12	D17	D8	E2	KPP_COL3	N1
A13	D19	D7	J3	FEC_MDC	L1
A14	A3	D6	H1	FEC_MDIO	L2
A15	B4	D5	G1	FEC_TDATA0	L3
A16	C6	D4	G2	FEC_TDATA1	J4
A17	B5	D3	G3	FEC_TX_EN	M2
A18	D7	D2	E1	FEC_RDATA0	M1
A19	A4	D1	F3	FEC_RDATA1	M4
A20	B6	D0	E3	FEC_RX_DV	M3
A21	C7	LD0	Y7	FEC_TX_CLK	L4
A22	A5	LD1	V8	RTCK	W10
A23	A6	LD2	W7	TCK	V10
A24	B7	LD3	U8	TMS	Y9
A25	A7	LD4	Y6	TDI	W9
SD0	A12	LD5	V7	TDO	Y8
SD1	C13	LD6	W6	TRSTB	V9
SD2	B13	LD7	Y5	DE_B	W8
SD3	D14	LD8	V6	SJC_MOD	U9

Table 99. 17×17 mm Package i.MX25 Signal Contact Assignment (continued)

Signal Name	Contact Assignment	Signal Name	Contact Assignment	Signal Name	Contact Assignment
SD4	D13	LD9	W5	USBPHY1_VBUS	K17
SD5	A13	LD10	Y4	USBPHY1_DP	L18
SD6	D12	LD11	Y3	USBPHY1_DM	K18
SD7	A10	LD12	V5	USBPHY1_UID	J18
SD8	B9	LD13	W4	USBPHY1_RREF	L17
SD9	D10	LD14	V4	USBPHY2_DM	Y19
SD10	B10	LD15	W3	USBPHY2_DP	Y18
SD11	C10	HSYNC	U7	GPIO_A	N19
SD12	C9	VSYNC	U6	GPIO_B	N18
SD13	A9	LSCLK	U5	GPIO_C	P17
SD14	D9	OE_ACD	V3	GPIO_D	P19
SD15	A8	CONTRAST	U4	GPIO_E	P18
SDBA1	A16	PWM	W2	GPIO_F	R19
SDBA0	B15	CSI_D2	F18	EXT_ARMCLK	R20
DQM0	C12	CSI_D3	E19	UPLL_BYPCLK	U20
DQM1	C8	CSI_D4	F19	VSTBY_REQ	R18
RAS	C14	CSI_D5	G18	VSTBY_ACK	T20
CAS	C16	CSI_D6	E20	POWER_FAIL	T19
SDWE	A15	CSI_D7	E18	RESET_B	T18
SDCKE0	D15	CSI_D8	G19	POR_B	U19
SDCKE1	C15	CSI_D9	F20	CLKO	V20
SDCLK	B14	CSI_MCLK	H18	BOOT_MODE0	V19
SDCLK_B	A14	CSI_VSYNC	G20	BOOT_MODE1	W20
SDQS0	B12	CSI_HSYNC	H19	CLK_SEL	W19
SDQS1	B8	CSI_PIXCLK	H20	TEST_MODE	V18
EB0	B3	I2C1_CLK	F17	OSC24M_EXTAL	Y15
EB1	C5	I2C1_DAT	G17	OSC24M_XTAL	Y16
OE	D6	CSPI1_MOSI	T4	OSC32K_EXTAL	Y11
CS0	C3	CSPI1_MISO	W1	OSC32K_XTAL	Y10
CS1	D3	CSPI1_SS0	R4	TAMPER_A	N10
CS2	B16	CSPI1_SS1	V2	TAMPER_B	N11
CS3	A17	CSPI1_SCLK	U3	MESH_C	P11
CS4	D5	CSPI1_RDY	V1	MESH_D	P12
CS5	D4	UART1_RXD	U2	OSC_BYP	Y12

Table 99. 17×17 mm Package i.MX25 Signal Contact Assignment (continued)

Signal Name	Contact Assignment	Signal Name	Contact Assignment	Signal Name	Contact Assignment
NF_CE0	D2	UART1_TXD	U1	XP	V14
ECB	B2	UART1_RTS	T3	XN	U13
LBA	B1	UART1_CTS	T2	YP	V13
BCLK	D8	UART2_RXD	P4	YN	W12
RW	C4	UART2_TXD	T1	WIPER	U14
		UART2_RTS	R3	INAUX0	U11
		UART2_CTS	R2	INAUX1	V12
				INAUX2	U12

Table 100 lists the 17×17 mm package i.MX25 no connect contact assignments.

Table 100. 17×17 mm Package i.MX25 No Connect Contact Assignments

Signal Name	Contact Assignment
NC_BGA_B20	B20
NC_BGA_E17	E17
NC_BGA_H17	H17
NC_BGA_J19	J19
NC_BGA_M18	M18
NC_BGA_P20	P20
NC_BGA_U15	U15
NC_BGA_U16	U16
NC_BGA_V15	V15
NC_BGA_V16	V16
NC_BGA_V17	V17
NC_BGA_W14	W14
NC_BGA_Y2	Y2
NC_BGA_Y14	Y14
NC_BGA_Y17	Y17

4.4 i.MX25 17x17 Package Ball Map

Table 101 shows the i.MX25 17×17 package ball map.

Table 101. i.MX25 17×17 Package Ball Map

20	QGND	NC_BGA_B20	A4	A11	CSL_D6	CSL_D9	CSL_VSYNC	CSL_PIXCLK	SD1_DATA3
19	A5	A7	A6	A13	CSL_D3	CSL_D4	CSL_D8	CSL_HSYNC	NC_BGA_J19
18	A0	A3	A9	A8	CSL_D7	CSL_D2	CSL_D5	CSL_MCLK	USBPHY1_UID
17	CS3	A1	A2	A12	NC_BGA_E17	I2C1_CLK	I2C1_DAT	NC_BGA_H17	USBPHY1_VSSA_BIAS
16	SDBA1	CS2	CAS	MA10	QGND	QGND	QGND	QGND	QGND
15	SDWE	SDBA0	SDCKE1	SDCKE0	QGND	QGND	NVCC_EM12	QGND	QGND
14	SDCLK_B	SDCLK	RAS	SD3	QGND	QGND	NVCC_EM12	NVCC_EM12	NVCC_CSI
13	SD5	SD2	SD1	SD4	QGND	QGND	NVCC_EM12	NVCC_EM12	NVCC_CSI
12	SD0	SDQ0	DQM0	SD6	QGND	QGND	NVCC_EM12	NVCC_EM12	QVDD
11	QGND	QGND	QGND	QGND	QGND	QGND	QVDD	QGND	QGND
10	SD7	SD10	SD11	SD9	QGND	QGND	QGND	QGND	QGND
9	SD13	SD8	SD12	SD14	QGND	QGND	NVCC_EM11	QGND	QGND
8	SD15	SDQ01	DQM1	BCLK	QGND	QGND	NVCC_EM11	NVCC_EM11	QVDD
7	A25	A24	A21	A18	QGND	QGND	NVCC_EM11	NVCC_EM11	NVCC_EM11
6	A23	A20	A16	OE	QGND	QGND	NVCC_EM11	NVCC_EM11	NVCC_EM11
5	A22	A17	EB1	CS4	QGND	QGND	QGND	QGND	QGND
4	A19	A15	RW	CS5	NFCLE	NFALE	NFWE_B	NFWP_B	FEC_TDATA1
3	A14	EBO	CS0	CS1	D0	D1	D3	D12	D7
2	A10	ECB	NFRB	NF_CEO	D8	D10	D4	D13	D15
1	QGND	LBA	NFRE_B	D9	D2	D11	D5	D6	D14
A	B	C	D	E	F	G	H	J	

Table 101. i.MX25 17×17 Package Ball Map (continued)

20	SD1_CMD	SD1_DATA0	SD1_CLK	SD1_DATA1	NC_BGA_P20	EXT_ARMCLK	VSTBY_ACK
19	USBPHY1_VDDA_BIAS	USBPHY1_VSSA	SD1_DATA2	GPIO_A	GPIO_D	GPIO_F	POWER_FAIL
18	USBPHY1_DM	USBPHY1_DP	NC_BGA_M18	GPIO_B	GPIO_E	VSTBY_REQ	RESET_B
17	USBPHY1_VBUS	USBPHY1_RREF	USBPHY1_UPLLVD	USBPHY1_UPLLVSS	GPIO_C	NVCC_SDIO	FUSE_VDD
16	USBPHY1_VDDA	UPLL_VDD	UPLL_GND	QGND	QGND	QGND	QGND
15	QGND	QGND	QGND	QGND	QGND	QGND	QGND
14	QGND	QGND	QGND	NVCC_CRM	QGND	QGND	QGND
13	QGND	QGND	QGND	QGND	QGND	QGND	QGND
12	QVDD	QGND	QGND	QGND	MESH_D	QGND	QGND
11	QGND	QGND	QGND	TAMPER_B	MESH_C	QGND	QGND
10	QGND	QGND	QGND	TAMPER_A	BAT_VDD	QGND	QGND
9	QGND	QGND	QGND	QGND	QVDD	QGND	QGND
8	QGND	NVCC_NFC	QGND	QVDD	QVDD	QGND	QGND
7	QVDD	NVCC_NFC	QVDD	NVCC_MISC	NVCC_LCDC	NVCC_LCDC	QGND
6	QVDD	NVCC_NFC	QVDD	NVCC_MISC	NVCC_LCDC	NVCC_LCDC	QGND
5	QGND	QGND	QVDD	NVCC_MISC	QGND	QGND	QGND
4	QGND	FEC_TX_CLK	FEC_RDATA1	KPP_ROW0	UART2_RXD	CSP11_SS0	CSP11_MOSI
3	QGND	FEC_TDATA0	FEC_RX_DV	KPP_COL1	KPP_ROW2	UART2_RTS	UART1_RTS
2	QGND	FEC_MDIO	FEC_TX_EN	KPP_COL2	KPP_ROW3	UART2_CTS	UART1_CTS
1	QGND	FEC_MDC	FEC_RDATA0	KPP_COL3	KPP_COL0	KPP_ROW1	UART2_TXD
	K	L	M	N	P	R	T

Table 101. i.MX25 17×17 Package Ball Map (continued)

20	UPLL_BYPCLK	CLKO	BOOT_MODE1	QGND
19	POR_B	BOOT_MODE0	CLK_SEL	USBPHY2_DM
18	MPLL_VDD	TEST_MODE	USBPHY2_VDD	USBPHY2_DP
17	MPLL_GND	NC_BGA_V17	USBPHY2_VSS	NC_BGA_Y17
16	NC_BGA_U16	NC_BGA_V16	OSC24M_VDD	OSC24M_XTAL
15	NC_BGA_U15	NC_BGA_V15	OSC24M_GND	OSC24M_EXTAL
14	WIPEP	XP	NC_BGA_W14	NC_BGA_Y14
13	XN	YP	NVCC_ADC	NGND_ADC
12	INAUX2	INAUX1	YN	OSC_BYP
11	INAUX0	REF	NVCC_DRYICE	OSC32K_EXTAL
10	NVCC_JTAG	TCCK	RTCK	OSC32K_XTAL
9	SJC_MOD	TRSTB	TDI	TMS
8	LD3	LD1	DE_B	TDO
7	HSYNC	LD5	LD2	LD0
6	VSYNC	LD8	LD6	LD4
5	LSCLK	LD12	LD9	LD7
4	CONTRAST	LD14	LD13	LD10
3	CSP11_SCLK	OE_ACD	LD15	LD11
2	UART1_RXD	CSP11_SS1	PWM	NC_BGA_Y2
1	UART1_TXD	CSP11_RDY	CSP11_MISO	QGND
	U	V	W	Y

4.5 347 MAPBGA—Case 12 x 12 mm, 0.5 mm Pitch

Figure 99 shows the 12×12 mm i.MX25 production package. The following notes apply to Figure 99:

- All dimensions in millimeters.
- Dimensioning and tolerancing per ASME Y14.5M-1994.
- Maximum solder ball diameter measured parallel to datum A.
- Datum A, the seating plane, is determined by the spherical crowns of the solder balls.
- Parallelism measurement shall exclude any effect of mark on package's top surface.

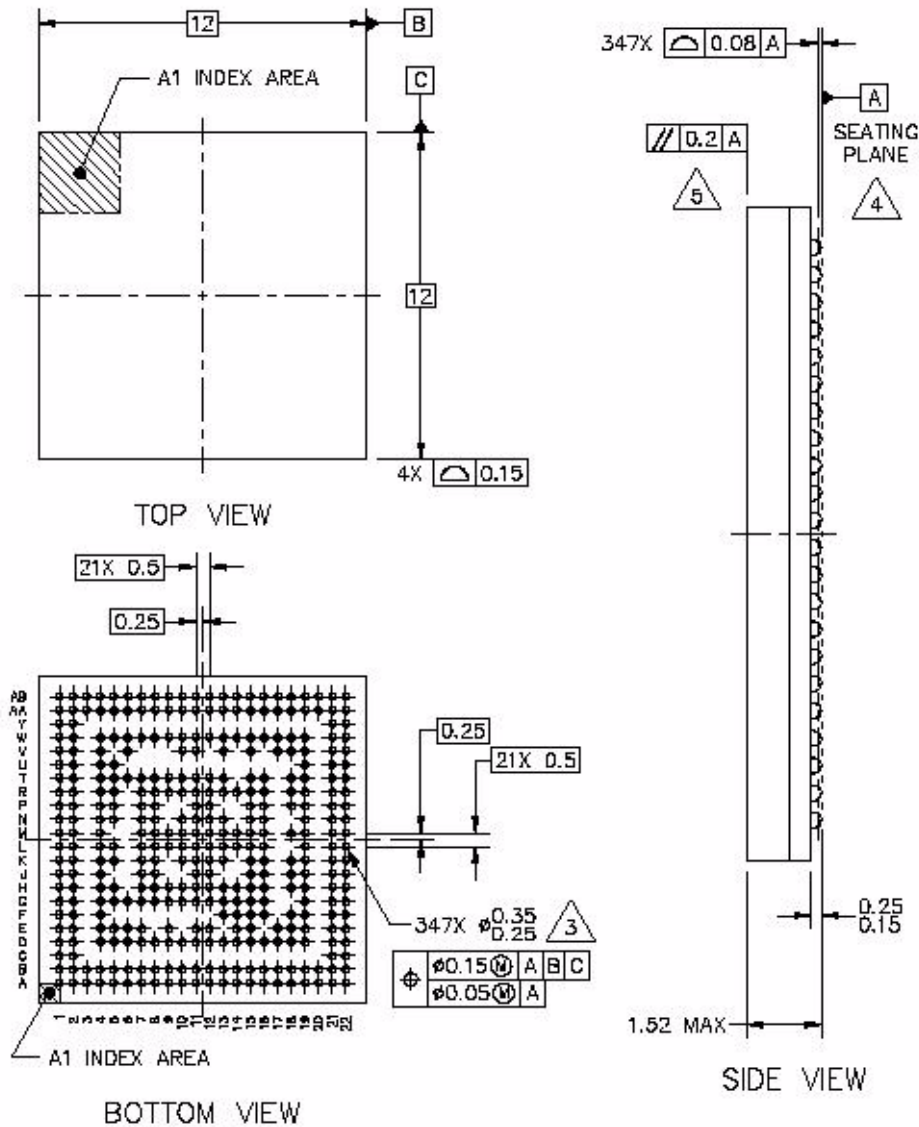

Figure 99. 12×12 mm i.MX25 Production Package

4.6 Ground, Power, Sense, and Reference Contact Assignments Case 12x12 mm, 0.5 mm Pitch

Table 102 shows the 12×12 mm package ground, power, sense, and reference contact assignments.

Table 102. 12x12 mm Package Ground, Power Sense, and Reference Contact Assignments

Contact Name	Contact Assignment
BATT_VDD	AA10
FUSE_VDD	P18
MPLL_GND	V17
MPLL_VDD	W19
NGND_ADC	N15
NVCC_ADC	P15
NVCC_CRM	P16
NVCC_CSI	J15, J16
NVCC_DRYICE	R14
NVCC_EMI1	G8, G9, G10, H8, H9, H10
NVCC_EMI2	E15, F15, G15, G16, H15, H16
NVCC_JTAG	W10
NVCC_LCDC	R8, R9, T8
NVCC_MISC	P7, P8, R7, T7
NVCC_NFC	J7, J8, K7, K8
NVCC_SDIO	N19
OSC24M_GND	T15
OSC24M_VDD	V15
QGND	A1, A22, B2, B14, B21, E18, F13, F14, F18, G6, G11, G12, G14, H11, H12, H14, J12, K10, K11, K12, K13, L7, L8, L9, L10, L11, L12, L13, L14, L15, L16, M7, M8, M9, M10, M11, M12, M13, M14, M15, M16, N10, N11, N12, N13, P11, P12, R11, R12, R18, T5, T6, T11, T12, T18, V18, V19, W2, W9, Y21, AA2, AA21, AB1, AB18, AB21, AB22, J11
QVDD	G7, G13, H7, H13, H18, J18, N7, N8, R10, R15, R16, T9, T10, V10,
REF	AA14
UPLL_GND	N16
UPLL_VDD	M18
UPLL_BYPCLK	U21
USBPHY1_UPLLVDD	L21
USBPHY1_UPLLVSS	M19
USBPHY1_VDDA	K15, K16
USBPHY1_VDDA_BIAS	L22
USBPHY1_VSSA	K19

Table 102. 12x12 mm Package Ground, Power Sense, and Reference Contact Assignments (continued)

Contact Name	Contact Assignment
USBPHY1_VSSA_BIAS	K18
USBPHY2_VDD	T16
USBPHY2_VSS	W16
USBPHY2_DP	W17
USBPHY1RREF	L19
USBPHY1_DM	J21
USBPHY1_DP	K21
USBPHY1_UID	J22
USBPHY1_VBUS	K22
USBPHY2_DM	W18

4.7 Signal Contact Assignments—12 x 12 mm, 0.5 mm Pitch

Table 103 lists the 12×12 mm package i.MX25 signal contact assignments.

Table 103. 12x12 mm Package i.MX25 Signal Contact Assignment

Ball Name	Ball Position	Ball Name	Ball Position	Ball Name	Ball Position
A0	A20	A23	E9	CSI_D9	H19
A1	A19	A24	B7	CSI_HSYNC	G22
A2	B18	A25	D8	CSI_MCLK	F22
A3	D17	BCLK	A8	CSI_PIXCLK	J19
A4	A21	BOOT_MODE0	AA22	CSI_VSYNC	G21
A5	B19	BOOT_MODE1	W21	CSPI1_MIS0	V4
A6	D18	CAS	B16	CSPI1_MOS0	V4
A7	B20	CLK0	Y22	CSPI1_MOS1	AA1
A8	E19	CL_SEL	AA20	CSPI1_SCLK	Y1
A9	D19	CONTRAST	Y2	CSPI1_SS0	V2
A10	B5	CS0	C2	CSPI1_SS1	U4
A11	C21	CS1	D4	CSPI1_RDY	U5
A12	B22	CS2	b17	D0	F2
A13	D21	CS3	A18	D1	F1
A14	A4	CS4	E5	D2	G1
A15	D6	CS5	D2	D3	H1
A16	A5	CSI_D2	C22	D4	H2
A17	E6	CSI_D3	F19	D5	J1
A18	A6	CSI_D4	E21	D6	k1

Table 103. 12x12 mm Package i.MX25 Signal Contact Assignment (continued)

Ball Name	Ball Position	Ball Name	Ball Position	Ball Name	Ball Position
A19	E7	CSI_D5	G19	D7	L1
A20	B6	CSI_D6	D22	D8	G2
A21	D7	CSI_D7	F21	D9	H5
A22	A7	CSI_D8	E22	D10	H4
D11	K5	KPP_COL1	N5	OE_ACD	AA3
D12	J4	KPP_COL2	P2	OSC24M_EXTAL	AB19
D13	J2	KPP_COL3	N4	OSC24M_EXTAL	AB20
D14	K4	KPP_ROW0	R2	OSC32K_EXTAL	AB13
D15	K2	KPP_ROW1	R4	OSC32K_XTAL	AB12
DE_B	W11	KPP_ROW2	U1	OSC_BYP	AB15
DQM0	D11	KPP_ROW3	P4	OE	A3
DQM1	A9	LBA	B3	POR_B	V21
EB0	A2	LD0	AB10	POWER_FAIL	T19
EB1	B4	LD1	W8	PWM	W4
ECB	B1	LD2	AB9	RAS	D15
EXT_ARMCLK	V22	LD3	AA9	RW	D5
FEC_MDC	P1	LD4	AB8	RESET_B	U19
FEC_MDIO	M2	LD5	AA8	RTCK	W13
FEC_RDATA0	M4	LD6	AB7	SD0	A13
FEC_RDATA1	N2	LD7	AA7	SD1	D12
FEC_RX_DV	L5	LD8	AB6	SD2	B12
FEC_TDATA0	L2	LD9	AA6	SD3	A14
FEC_TDATA1	M1	LD10	AB5	SD4	B13
FEC_TX_CLK	N1	LD11	W7	SD5	A15
FEC_TX_EN	R1	LD12	AB4	SD6	B11
GPIO_A	T22	LD13	W6	SD7	A12
GPIO_B	P21	LD14	AB3	SD8	D10
GPIO_C	U22	LD15	AA5	SD9	A10
GPIO_D	P19	LSCLK	AB2	SD10	A11
GPIO_E	R21	MA10	E17	SD11	B10
GPIO_F	R19	MESH_C	T13	SD12	B9
HSYNC	AA4	MESH_D	R13	SD13	E11
I2C1_CLK	H22	NFALE	E2	SD14	B8
I2C1_DAT	H21	NF_CEO	F4	SD15	D9
INAUX0	AA15	NFCLE	D1	SDBA0	A17

Table 103. 12x12 mm Package i.MX25 Signal Contact Assignment (continued)

Ball Name	Ball Position	Ball Name	Ball Position	Ball Name	Ball Position
INAUX1	W14	NFRB	G5	SDBA1	D16
INAUX2	AB16	NFRE_B	C1	SDCKE0	A16
K4	D14	NFWE_B	E1	SDCKE1	F16
KPP_COL0	T1	NFWP_B	G4	SDCLK	D13
SDCLK_B	D14	TAMPER_A	V11	UART2_RXD	V1
SD1_CLK	N21	TAMPER_B	V13	UART1_RTS	W1
SD1_DATA0	P22	TCK	AA13	UART2_RTS	T2
SD1_DATA1	R22	TD0	AA11	UART1_TXD	V6
SD1_DATA2	M22	TDI	W12	VSYNC	W5
SD1_DATA3	M21	TEST_MODE	AA19	VSTBY_ACK	W22
SD1_CMD	N22	TMS	AA12	VSTBY_REQ	T21
SDQS0	E14	TRSTB	AB14	WIPER	AA17
SDQS1	E12	UART1_CTS	R5	XN	AA16
SDWE	B15	UART2_CTS	P5	XP	AA18
SJC_MOD	AB11	UART1_RXD	U2	YN	W15
				YP	AB17

Table 104 lists the 12x12 mm package i.MX25 no connect contact assignments.

Table 104. 12x12 mm Package i.MX25 No Connect Contact Assignments

Signal Name	Contact Assignment
NC_BGA_E4	E4
NC_BGA_L4	L4

4.8 i.MX25 12x12 Package Ball Map

Table 101 shows the i.MX25 12x12 package ball map.

Table 105. i.MX25 12x12 Package Ball Map

	A	B	C	D	E	F	G	H	J	K
22	QGND	A12	CS1_D2	CS1_D6	CS1_D8	CS1_MCLK	CS1_HSYNC	I2C1_CLK	USBPHY1_UID	USBPHY1_VBUS
21	A4	QGND	A11	A13	CS1_D4	CS1_D7	CS1_VSYNC	I2C1_DAT	USBPHY1_DM	USBPHY1_DP
20	A0	A7								
19	A1	A5		A9	A8	CS1_D3	CS1_D5	CS1_D9	CS1_PIXCLK	USBPHY1_VSSA
18	CS3	A2		A6	QGND	QGND		QVDD	QVDD	USBPHY1_VSSA_BIAS
17	SDBA0	CS2		A3	MA10					
16	SDCKE0	CAS		SDBA1		SDCKE1	NVCC_EMI2	NVCC_EMI2	NVCC_CSI	USBPHY1_VDDA
15	SD5	SDWE		RAS	NVCC_EMI2	NVCC_EMI2	NVCC_EMI2	NVCC_EMI2	NVCC_CSI	USBPHY1_VDDA
14	SD3	QGND		SDCLK_B	SDQS0	QGND	QGND	QGND		
13	SD0	SD4		SDCLK		QGND	QVDD	QVDD		QGND
12	SD7	SD2		SD1	SDQS1		QGND	QGND	QGND	QGND
11	SD10	SD6		DQM0	SD13		QGND	QGND	QGND	QGND
10	SD9	SD11		SD8			NVCC_EMI1	NVCC_EMI1		QGND
9	DQM1	SD12		SD15	A23		NVCC_EMI1	NVCC_EMI1		
8	BCLK	SD14		A25			NVCC_EMI1	NVCC_EMI1	NVCC_NFC	NVCC_NFC
7	A22	A24		A21	A19		QVDD	QVDD	NVCC_NFC	NVCC_NFC
6	A18	A20		A15	A17		QGND			
5	A16	A10		RW	CS4		NFRB	D9		D11
4	A14	EB1		CS1	NC_BGA_E4	NF_CE0	NFWP_B	D10	D12	D14
3	OE	LBA								
2	EB0	QGND	CS0	CS5	NFALE	D0	D8	D4	D13	D15
1	QGND	ECB	NFRE_B	NFCLE	NFWE_B	D1	D2	D3	D5	D6

Table 105. i.MX25 12x12 Package Ball Map (continued)

22	USBPHY1_VDDA_BIAS	SD1_DATA2	SD1_CMD	SD1_DATA0	SD1_DATA1	GPIO_A	GPIO_C	EXT_ARMCLK
21	USBPHY1_UPLLVD	SD1_DATA3	SD1_CLK	GPIO_B	GPIO_E	VSTBY_REQ	UPLL_BYPCLK	POR_B
20								
19	USBPHY1_RREF	USBPHY1_UPLLVSS	NVCC_SDIO	GPIO_D	GPIO_F	POWER_FAIL	RESET_B	QGND
18		UPLL_VDD		FUSE_VDD	QGND	QGND		QGND
17								MPLL_GND
16	QGND	QGND	UPLL_GND	NVCC_CRM	QVDD	USBPHY2_VDD		
15	QGND	QGND	NGND_ADC	NVCC_ADC	QVDD	OSC24M_GND		OSC24M_VDD
14	QGND	QGND			NVCC_DRYICE			
13	QGND	QGND	QGND		MESH_D	MESH_C		TAMPER_B
12	QGND	QGND	QGND	QGND	QGND	QGND		
11	QGND	QGND	QGND	QGND	QGND	QGND		TAMPER_A
10	QGND	QGND	QGND		QVDD	QVDD		QVDD
9	QGND	QGND			NVCC_LCDC	QVDD		
8	QGND	QGND	QVDD	NVCC_MISC	NVCC_LCDC	NVCC_LCDC		
7	QGND	QGND	QVDD	NVCC_MISC	NVCC_MISC	NVCC_MISC		
6						QGND		UART1_TXD
5	FEC_RX_DV		KPP_COL1	UART2_CTS	UART1_CTS	QGND	CSP11_RDY	
4	NC_BGA_L4	FEC_RDATA0	KPP_COL3	KPP_ROW3	KPP_ROW1	UART2_TXD	CSP11_SS1	CSP11_MISO
3								
2	FEC_TDATA0	FEC_MDIO	FEC_RDATA1	KPP_COL2	KPP_ROW0	UART2_RTS	UART1_RXD	CSP11_SSO
1	D7	FEC_TDATA1	FEC_TX_CLK	FEC_MDC	FEC_TX_EN	KPP_COLO	KPP_ROW2	UART2_RXD
	L	M	N	P	R	T	U	V

Table 105. i.MX25 12×12 Package Ball Map (continued)

22	VSTBY_ACK	CLKO	BOOT_MODE0	QGND
21	BOOT_MODE1	QGND	QGND	QGND
20			CLK_SEL	OSC24M_XTAL
19	MPLL_VDD		TEST_MODE	OSC24M_EXTAL
18	USBPHY2_DM		XP	QGND
17	USBPHY2_DP		WIPER	YP
16	USBPHY2_VSS		XN	INAUX2
15	YN		INAUX0	OSC_BYP
14	INAUX1		REF	TRSTB
13	RTCK		TCK	OSC32K_EXTAL
12	TDI		TMS	OSC32K_XTAL
11	DE_B		TDO	SJC_MOD
10	NVCC_JTAG		BAT_VDD	LD0
9	QGND		LD3	LD2
8	LD1		LD5	LD4
7	LD11		LD7	LD6
6	LD13		LD9	LD8
5	VSYNC		LD15	LD10
4	PWM		HSYNC	LD12
3			OE_ACD	LD14
2	QGND	CONTRAST	QGND	LSCLK
1	UART1_RTS	CSP11_SCLK	CSP11_MOSI	QGND
	W	Y	AA	AB

5 Revision History

Table 106 summarizes revisions to this document.

Table 106. Revision History

Rev.	Date	Revision
6	09/2010	<ul style="list-style-type: none"> Added Section 3.2.3, "SRTC DryIce Power-Up/Down Sequence."
5	08/2010	<ul style="list-style-type: none"> Updated Table 54, "WEIM Bus Timing Parameters," on page 71 to include new row for WE19. Updated Table 6, "DC Operating Conditions," on page 11 to include Min and Max values of FUSE_VDD.
4	06/2010	<ul style="list-style-type: none"> Updated Table 1, "Ordering Information," to include new part numbers.
3	03/2010	<ul style="list-style-type: none"> Updated Table 1, "Ordering Information," to include new part numbers. Added Table 2, "i.MX25 Parts Functional Differences." Added Section 3.3, "Power Characteristics." Added Section 4.5, "347 MAPBGA—Case 12 x 12 mm, 0.5 mm Pitch." Added Section 4.6, "Ground, Power, Sense, and Reference Contact Assignments Case 12x12 mm, 0.5 mm Pitch." Added Section 4.7, "Signal Contact Assignments—12 x 12 mm, 0.5 mm Pitch." Added Section 4.8, "i.MX25 12x12 Package Ball Map."
2	12/2009	<ul style="list-style-type: none"> Updated Table 1, "Ordering Information," to include new part numbers.
1	10/2009	<ul style="list-style-type: none"> Updated Table 1, "Ordering Information," to include new part numbers. Updated DRYICE description in Table 3, "i.MX25 Digital and Analog Modules." Updated REF signal description in Table 4, "Signal Considerations." Updated ESD damage immunity values in Table 5, "DC Absolute Maximum Ratings." Updated values in Table 11, "i.MX25 Power Mode Current Consumption." Added a note on timing in Section 3.2.1, "Power-Up Sequence." Added Table 12, "i.MX25 Reduced Power Mode Current Consumption." Updated Table 53, "NFC Timing Parameters." Updated values in Table 54, "WEIM Bus Timing Parameters." Updated Table 83, "Touchscreen ADC Electrical Specifications."
0	6/2009	Initial release.

How to Reach Us:

Home Page:

www.freescale.com

Web Support:

<http://www.freescale.com/support>

USA/Europe or Locations Not Listed:

Freescale Semiconductor, Inc.
Technical Information Center, EL516
2100 East Elliot Road
Tempe, Arizona 85284
1-800-521-6274 or
+1-480-768-2130
www.freescale.com/support

Europe, Middle East, and Africa:

Freescale Halbleiter Deutschland GmbH
Technical Information Center
Schatzbogen 7
81829 Muenchen, Germany
+44 1296 380 456 (English)
+46 8 52200080 (English)
+49 89 92103 559 (German)
+33 1 69 35 48 48 (French)
www.freescale.com/support

Japan:

Freescale Semiconductor Japan Ltd.
Headquarters
ARCO Tower 15F
1-8-1, Shimo-Meguro, Meguro-ku
Tokyo 153-0064
Japan
0120 191014 or
+81 3 5437 9125
support.japan@freescale.com

Asia/Pacific:

Freescale Semiconductor China Ltd.
Exchange Building 23F
No. 118 Jianguo Road
Chaoyang District
Beijing 100022
China
+86 10 5879 8000
support.asia@freescale.com

For Literature Requests Only:

Freescale Semiconductor
Literature Distribution Center
1-800 441-2447 or
+1-303-675-2140
Fax: +1-303-675-2150
LDCForFreescaleSemiconductor@hibbertgroup.com

Information in this document is provided solely to enable system and software implementers to use Freescale Semiconductor products. There are no express or implied copyright licenses granted hereunder to design or fabricate any integrated circuits or integrated circuits based on the information in this document.

Freescale Semiconductor reserves the right to make changes without further notice to any products herein. Freescale Semiconductor makes no warranty, representation or guarantee regarding the suitability of its products for any particular purpose, nor does Freescale Semiconductor assume any liability arising out of the application or use of any product or circuit, and specifically disclaims any and all liability, including without limitation consequential or incidental damages. "Typical" parameters that may be provided in Freescale Semiconductor data sheets and/or specifications can and do vary in different applications and actual performance may vary over time. All operating parameters, including "Typicals", must be validated for each customer application by customer's technical experts. Freescale Semiconductor does not convey any license under its patent rights nor the rights of others. Freescale Semiconductor products are not designed, intended, or authorized for use as components in systems intended for surgical implant into the body, or other applications intended to support or sustain life, or for any other application in which the failure of the Freescale Semiconductor product could create a situation where personal injury or death may occur. Should Buyer purchase or use Freescale Semiconductor products for any such unintended or unauthorized application, Buyer shall indemnify and hold Freescale Semiconductor and its officers, employees, subsidiaries, affiliates, and distributors harmless against all claims, costs, damages, and expenses, and reasonable attorney fees arising out of, directly or indirectly, any claim of personal injury or death associated with such unintended or unauthorized use, even if such claim alleges that Freescale Semiconductor was negligent regarding the design or manufacture of the part.

RoHS-compliant and/or Pb-free versions of Freescale products have the functionality and electrical characteristics as their non-RoHS-compliant and/or non-Pb-free counterparts. For further information, see <http://www.freescale.com> or contact your Freescale sales representative.

For information on Freescale's Environmental Products program, go to <http://www.freescale.com/epp>.

Freescale, the Freescale logo, CodeWarrior, ColdFire, PowerQUICC, StarCore, and Symphony are trademarks of Freescale Semiconductor, Inc. Reg. U.S. Pat. & Tm. Off. CoreNet, QorIQ, QUICC Engine, and VortiQa are trademarks of Freescale Semiconductor, Inc. All other product or service names are the property of their respective owners. ARM is the registered trademark of ARM Limited. ARM926EJ-S is the trademark of ARM Limited. © 2010 Freescale Semiconductor, Inc.

Document Number: IMX25CEC

Rev. 6
09/2010

