

ISO HIGH SIDE SMART POWER SOLID STATE RELAY

Table 1. General Features

Type	V _{DSS}	R _{DS(on)}	I _n ⁽¹⁾	V _{CC}
VN16B	40 V	0.06 Ω	5.6 A	26 V

Note: 1. Nominal current according to ISO definition for high side automotive switch. The Nominal Current is the current at T_c = 85 °C for battery voltage of 13V which produces a voltage drop of 0.5 V

- MAXIMUM CONTINUOUS OUTPUT CURRENT (note 2): 20 A @ T_c= 85°C
- 5V LOGIC LEVEL COMPATIBLE INPUT
- THERMAL SHUT-DOWN
- UNDER VOLTAGE PROTECTION
- OPEN DRAIN DIAGNOSTIC OUTPUT
- INDUCTIVE LOAD FAST DEMAGNETIZATION
- VERY LOW STAND-BY POWER DISSIPATION

DESCRIPTION

The VN16B is a monolithic device made using STMicroelectronics VIPower Technology, intended for driving resistive or inductive loads with one side grounded.

Built-in thermal shut-down protects the chip from over temperature and short circuit.

The open drain diagnostic output indicates: open load in off state and in on state, output shorted to V_{CC} and overtemperature. Fast demagnetization of inductive loads is achieved by negative (-18V) load voltage at turn-off.

Note: 2. The maximum continuous output current is the current at T_c = 85 °C for a battery voltage of 13 V which does not activate self protection.

Table 2. Order Codes

Package	Tube	Tape and Reel
PENTAWATT Vert.	VN16B	-
PENTAWATT Hor.	VN16B(011Y)	-
PENTAWATT In line	VN16B(012Y)	-

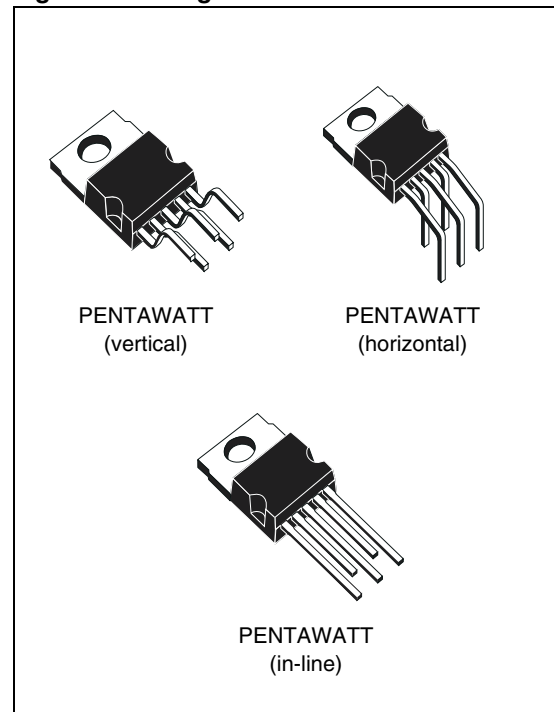
Figure 1. Package


Figure 2. Block Diagram

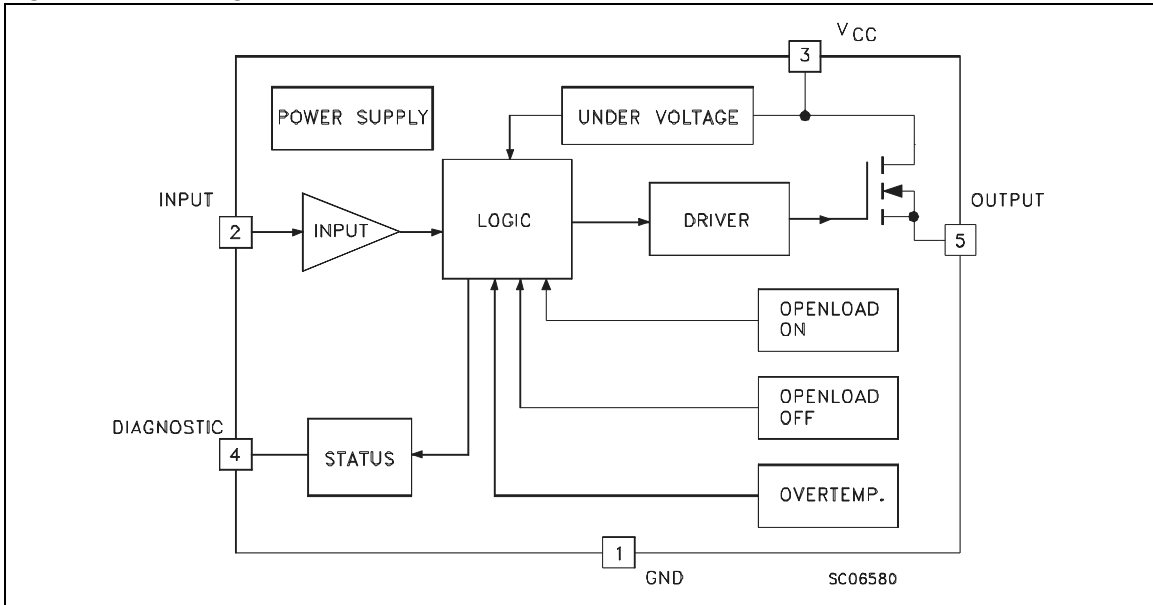


Table 3. Absolute Maximum Ratings

Symbol	Parameter	Value	Unit
$V_{(BR)DSS}$	Drain-Source Breakdown Voltage	40	V
I_{OUT}	Output Current (cont.) at $T_c = 85\text{ }^\circ\text{C}$	20	A
$I_{OUT(RMS)}$	RMS Output Current at $T_c = 85\text{ }^\circ\text{C}$	20	A
I_R	Reverse Output Current at $T_c = 85\text{ }^\circ\text{C}$ ($f > 1\text{Hz}$)	-20	A
I_{IN}	Input Current	± 10	mA
$-V_{CC}$	Reverse Supply Voltage	-4	V
I_{STAT}	Status Current	± 10	mA
V_{ESD}	Electrostatic Discharge (1.5 k Ω , 100 pF)	2000	V
P_{tot}	Power Dissipation at $T_c = 25\text{ }^\circ\text{C}$	82	W
T_j	Junction Operating Temperature	-40 to 150	$^\circ\text{C}$
T_{stg}	Storage Temperature	-55 to 150	$^\circ\text{C}$

Figure 3. Connection Diagram

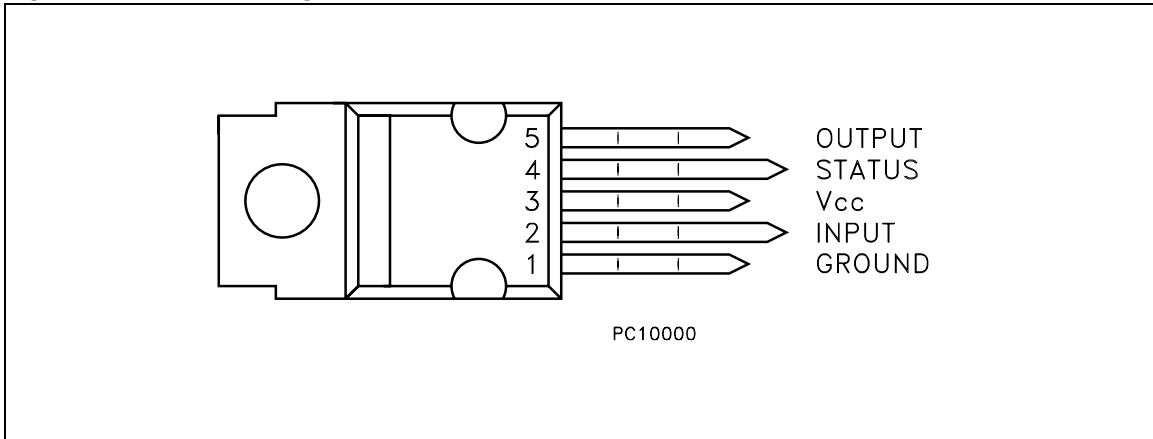


Figure 4. Current and Voltage Conventions

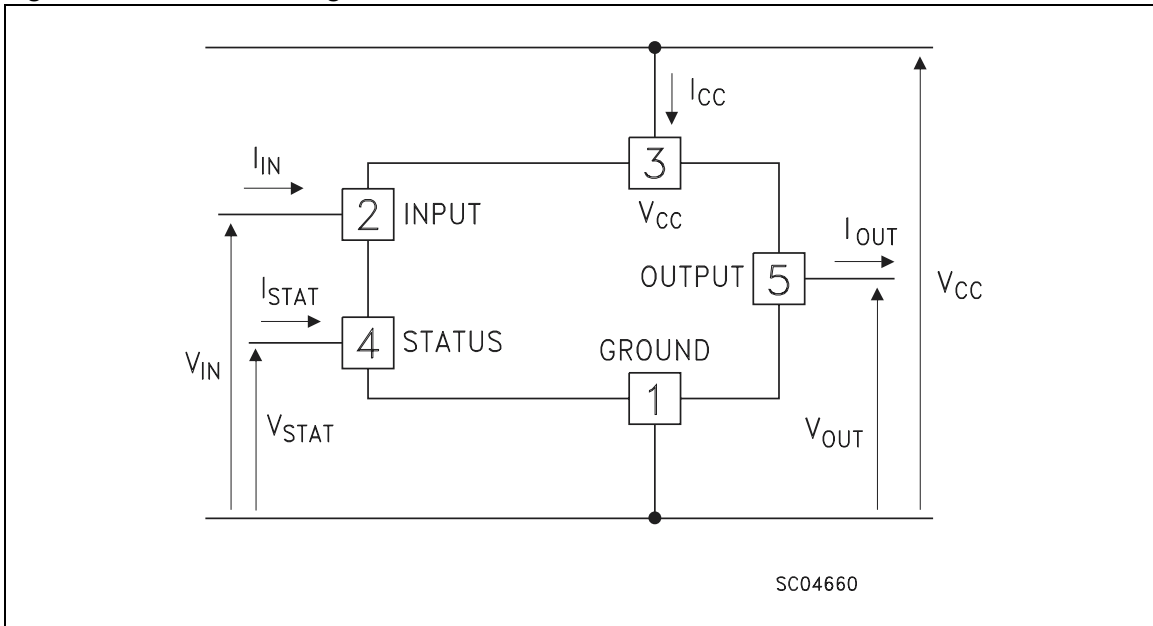


Table 4. Thermal Data

Symbol	Parameter	Value	Unit
$R_{thj-case}$	Thermal Resistance Junction-case Max	1.5	°C/W
$R_{thj-amb}$	Thermal Resistance Junction-ambient Max	60	°C/W

ELECTRICAL CHARACTERISTICS(8 < V_{CC} < 16 V; -40 ≤ T_j ≤ 125 °C unless otherwise specified)**Table 5. Power**

Symbol	Parameter	Test Conditions	Min.	Typ.	Max.	Unit
V _{CC}	Supply Voltage		6	13	26	V
I _n ⁽³⁾	Nominal Current	T _c = 85 °C V _{DS(on)} ≤ 0.5; V _{CC} = 13 V	5.6		8.8	A
R _{on}	On State Resistance	I _{OUT} = I _n ; V _{CC} = 13 V; T _j = 25 °C	0.038		0.06	Ω
I _S	Supply Current	Off State; V _{CC} = 13 V; T _j ≥ 25 °C		25	50	μA
V _{DS(MAX)}	Maximum Voltage Drop	I _{OUT} = 20 A; V _{CC} = 13 V; T _c = 85 °C	1		1.8	V
R _i	Output to GND Internal Impedance	T _j = 25 °C	5	10	20	KΩ

Note: 3. Nominal current according to ISO definition for high side automotive switch The Nominal Current is the current at T_c = 85 °C for battery voltage of 13V which produces a voltage drop of 0.5 V.

Table 6. Switching

Symbol	Parameter	Test Conditions	Min.	Typ.	Max.	Unit
t _{d(on)} ⁽⁴⁾	Turn-on Delay Time Of Output Current	R _{load} = 1.6 Ω	5	50	500	μs
t _r ⁽⁴⁾	Rise Time Of Output Current	R _{load} = 1.6 Ω	40	100	680	μs
t _{d(off)} ⁽⁴⁾	Turn-off Delay Time Of Output Current	R _{load} = 1.6 Ω	10	100	500	μs
t _f ⁽⁴⁾	Fall Time Of Output Current	R _{load} = 1.6 Ω	40	100	680	μs
(di/dt) _{on}	Turn-on Current Slope	R _{load} = 1.6 Ω; V _{CC} = 13 V	0.008		0.1	A/μs
(di/dt) _{off}	Turn-off Current Slope	R _{load} = 1.6 Ω; V _{CC} = 13 V	0.008		0.1	A/μs
V _{demag}	Inductive Load Clamp Voltage	R _{load} = 1.6 Ω; L = 1 mH	-24	-18	-14	V

Note: 4. See Switching Time Waveforms.

Table 7. Logic Input

Symbol	Parameter	Test Conditions	Min.	Typ.	Max.	Unit
V _{IL}	Input Low Level Voltage				1.5	V
V _{IH}	Input High Level Voltage		3.5		Note 5	V
V _{I(hyst)}	Input Hysteresis Voltage		0.2	1	1.5	V
I _{IN}	Input Current	V _{IN} = 5 V; T _j = 25 °C			100	μA
V _{ICL}	Input Clamp Voltage	I _{IN} = 10 mA I _{IN} = -10 mA	5	6 -0.7	7	V V

Note: 5. The V_{IH} is internally clamped at 6V about. It is possible to connect this pin to an higher voltage via an external resistor calculated to not exceed 10 mA at the input pin.

ELECTRICAL CHARACTERISTICS (cont'd)

Table 8. Protections and Diagnostics

Symbol	Parameter	Test Conditions	Min.	Typ.	Max.	Unit
V _{STAT}	Status Voltage Output Low	I _{STAT} = 1.6 mA			0.4	V
V _{USD}	Under Voltage Shut Down		3.5	5	6	V
V _{SCL}	Status Clamp Voltage	I _{STAT} = 10 mA I _{STAT} = -10 mA	5	6 -0.7	7	V V
T _{TSD}	Thermal Shut-down Temperature		140	160	180	°C
T _{SD(hyst.)}	Thermal Shut-down Hysteresis			15	50	°C
T _R	Reset Temperature		125			°C
V _{OL} ⁽⁶⁾	Open Voltage Level	Off-State	2.5	3.8	5	V
I _{OL}	Open Load Current Level	On-State	0.15		0.85	A
t _{povl} ⁽⁷⁾	Status Delay			5	10	µs
t _{pol} ⁽⁷⁾	Status Delay		50	400	2500	µs

Note: 6. $I_{OL(off)} = (V_{CC} - V_{OL})/R_{OL}$ (see figure 5).

7. t_{povi} t_{pol}: ISO definition (see figure 6).

Figure 5. Note 6 relevant figure

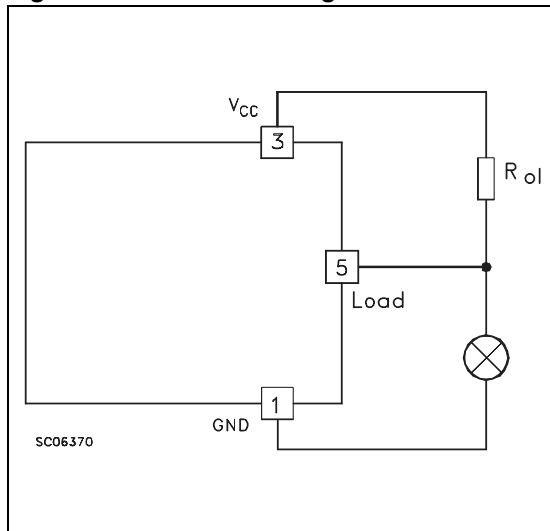


Figure 6. Note 7 relevant figure

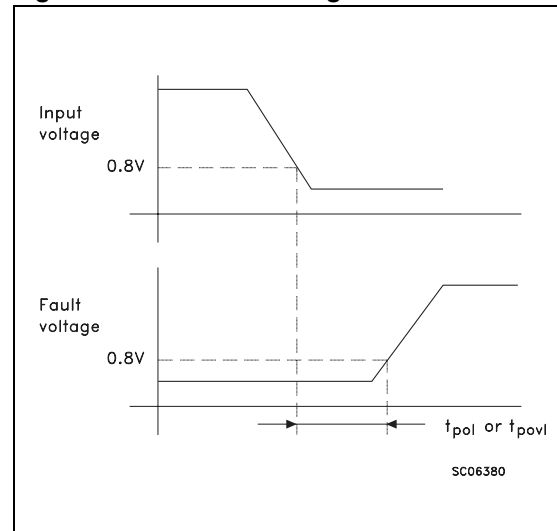
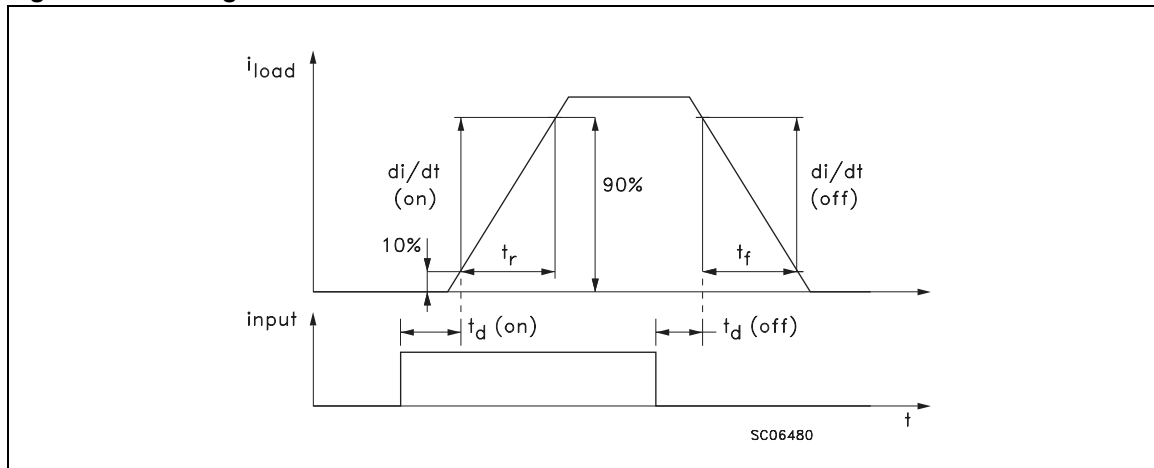


Figure 7. Switching Time Waveforms



FUNCTIONAL DESCRIPTION

The device has a diagnostic output which indicates open load in on-state, open load in off-state, over temperature conditions and stuck-on to V_{CC} .

From the falling edge of the input signal, the status output, initially low to signal a fault condition (overtemperature or open load on-state), will go back to a high state with a different delay in case of overtemperature (t_{povl}) and in case of open load (t_{pol}) respectively. This feature allows to discriminate the nature of the detected fault. To protect the device against short circuit and over current condition, the thermal protection turns the integrated Power MOS off at a minimum junction temperature of 140 °C. When this temperature returns to 125 °C the switch is automatically turned on again. In short circuit the protection reacts with virtually no delay, the sensor being located inside the Power MOS area. An internal function of the devices ensures the fast demagnetization of inductive loads with a typical voltage (V_{demag}) of -18V. This function allows to greatly reduce the power dissipation according to the formula:

$$P_{dem} = 0.5 \cdot L_{load} \cdot (I_{load})^2 \cdot [(V_{CC} + V_{demag}) / V_{demag}] \cdot f$$

where f = switching frequency and

V_{demag} = demagnetization voltage

The maximum inductance which causes the chip temperature to reach the shut-down temperature in a specified thermal environment is a function of

the load current for a fixed V_{CC} , V_{demag} and f according to the above formula. In this device if the GND pin is disconnected, with V_{CC} not exceeding 16V, it will switch off.

PROTECTING THE DEVICE AGAINST REVERSE BATTERY

The simplest way to protect the device against a continuous reverse battery voltage (-26V) is to insert a Schottky diode between pin 1 (GND) and ground, as shown in the typical application circuit (Figure 10).

The consequences of the voltage drop across this diode are as follows:

- If the input is pulled to power GND, a negative voltage of $-V_f$ is seen by the device. (V_{IL} , V_{IH} thresholds and V_{STAT} are increased by V_f with respect to power GND).
- The undervoltage shutdown level is increased by V_f .

If there is no need for the control unit to handle external analog signals referred to the power GND, the best approach is to connect the reference potential of the control unit to node [1] (see application circuit in Figure 10), which becomes the common signal GND for the whole control board avoiding shift of V_{IH} , V_{IL} and V_{STAT} . This solution allows the use of a standard diode.

Table 9. Truth Table

	Input	Output	Diagnostic
Normal Operation	L	L	H
	H	H	H
Over-temperature	X	L	L
Under-voltage	X	L	H
Short load to V _{CC}	H	H	L
	L	H	L
Open Load	H	H	L
	L	L	L ⁽⁸⁾

Note: 8. With an additional external resistor.

Figure 8. Waveforms

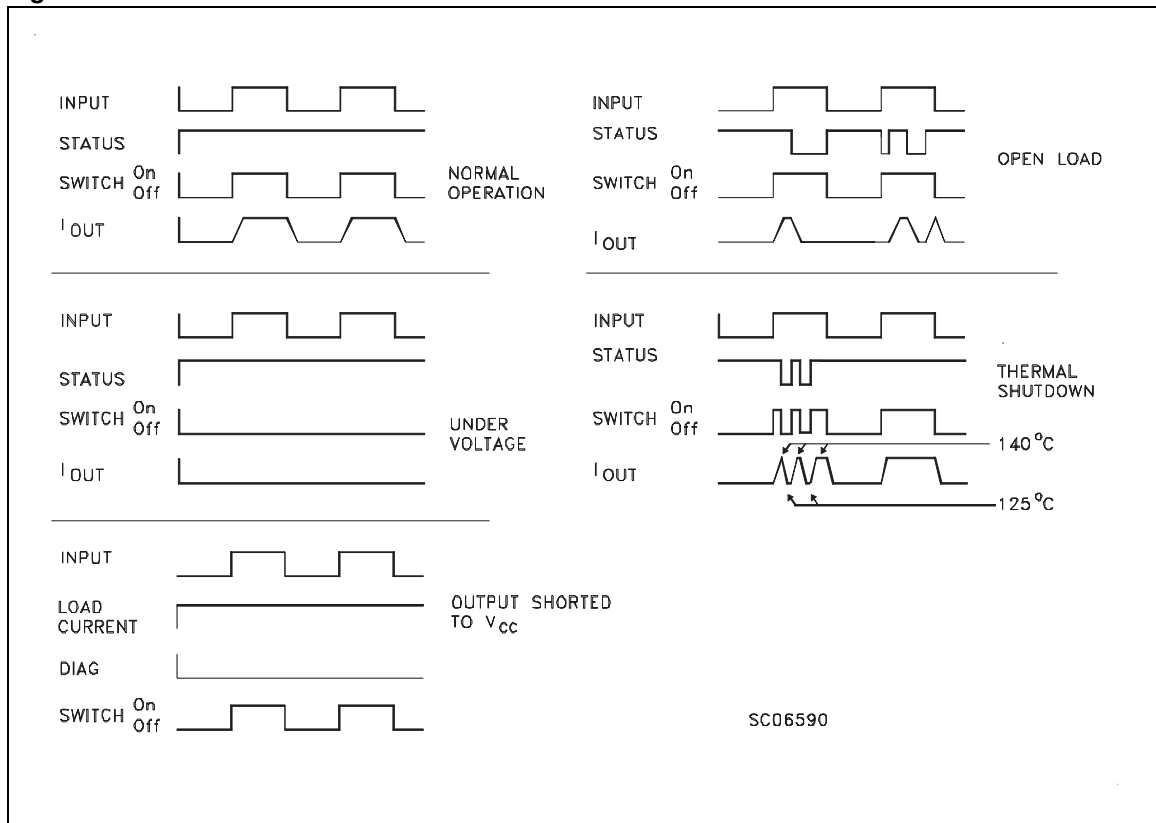


Figure 9. Over Current Test Circuit

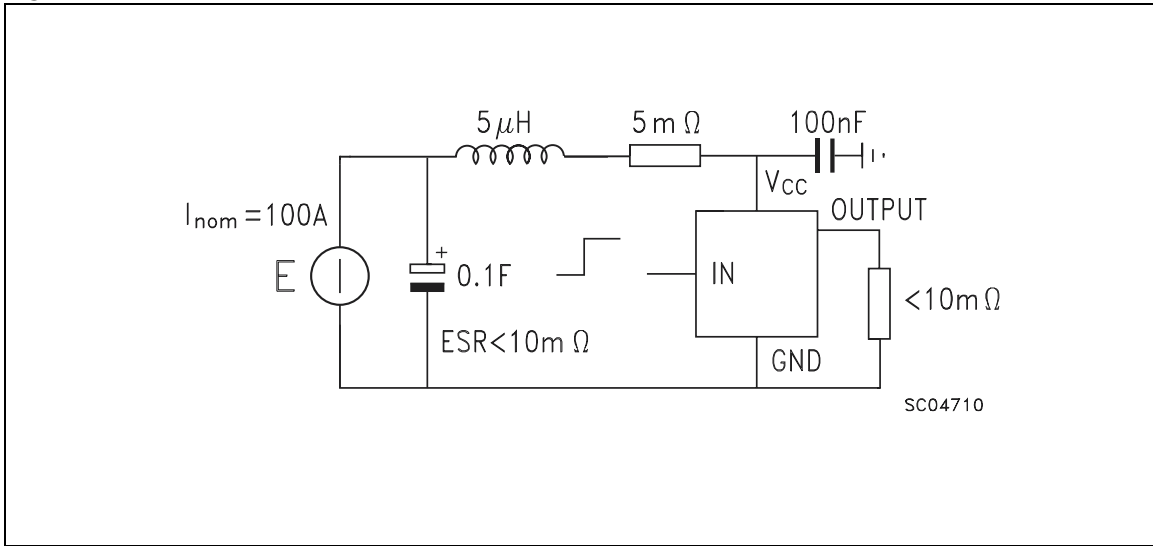


Figure 10. Typical Application Circuit With A Schottky Diode For Reverse Supply Protection

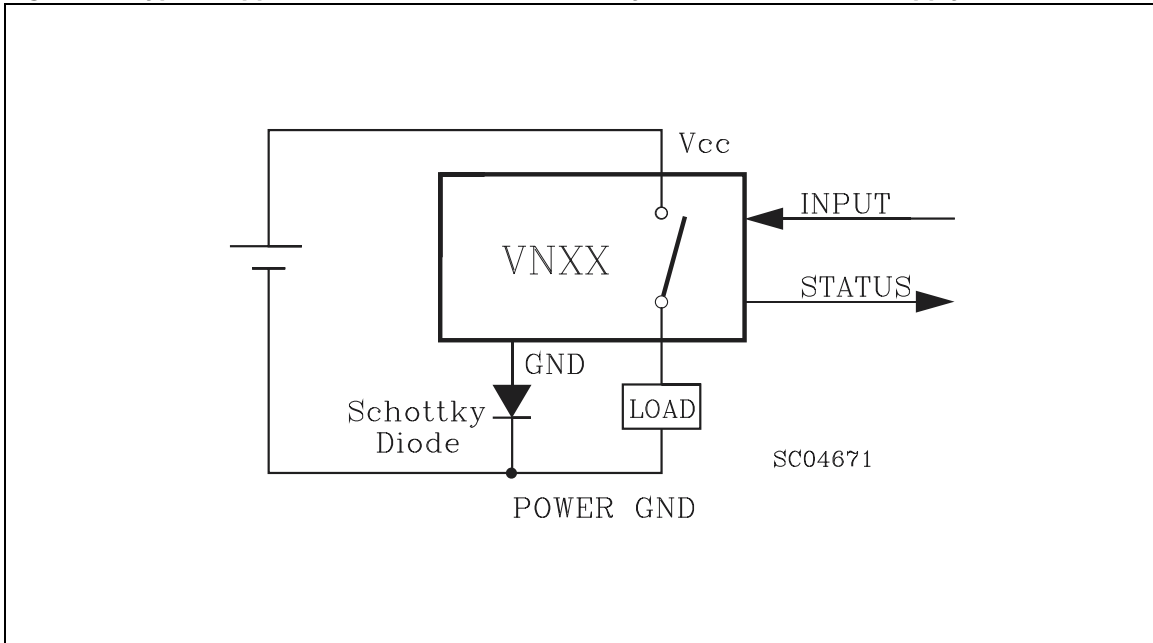
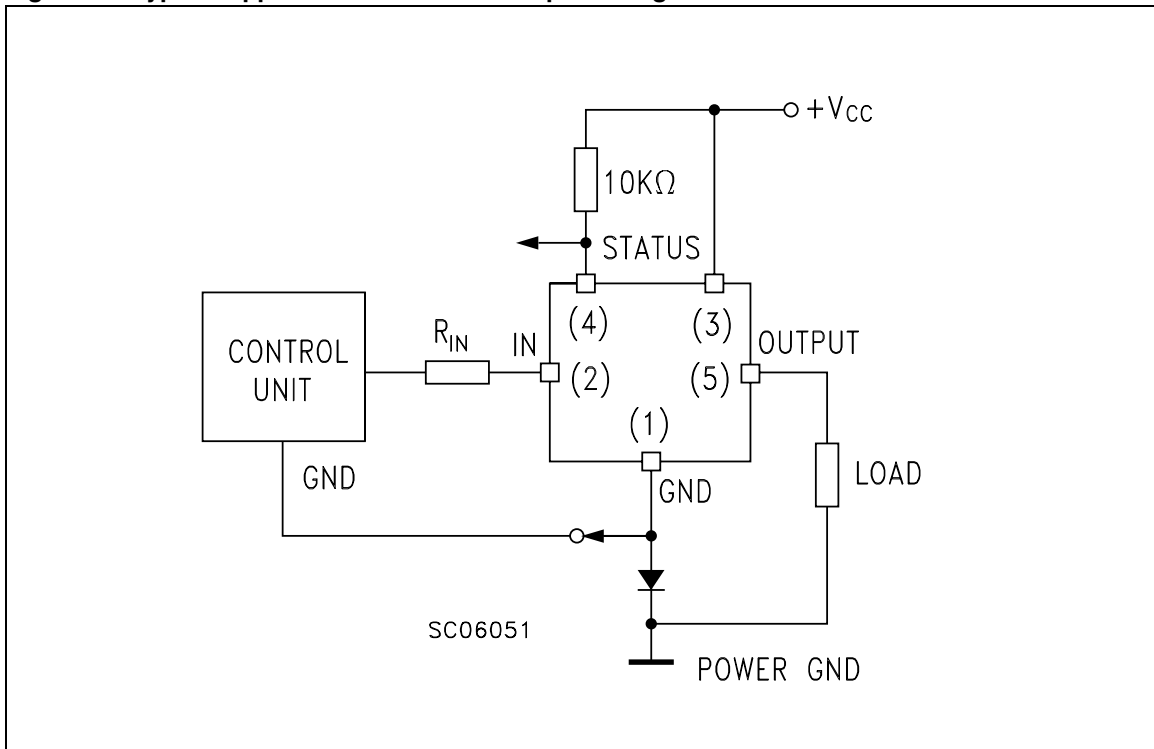


Figure 11. Typical Application Circuit With Separate Signal Ground

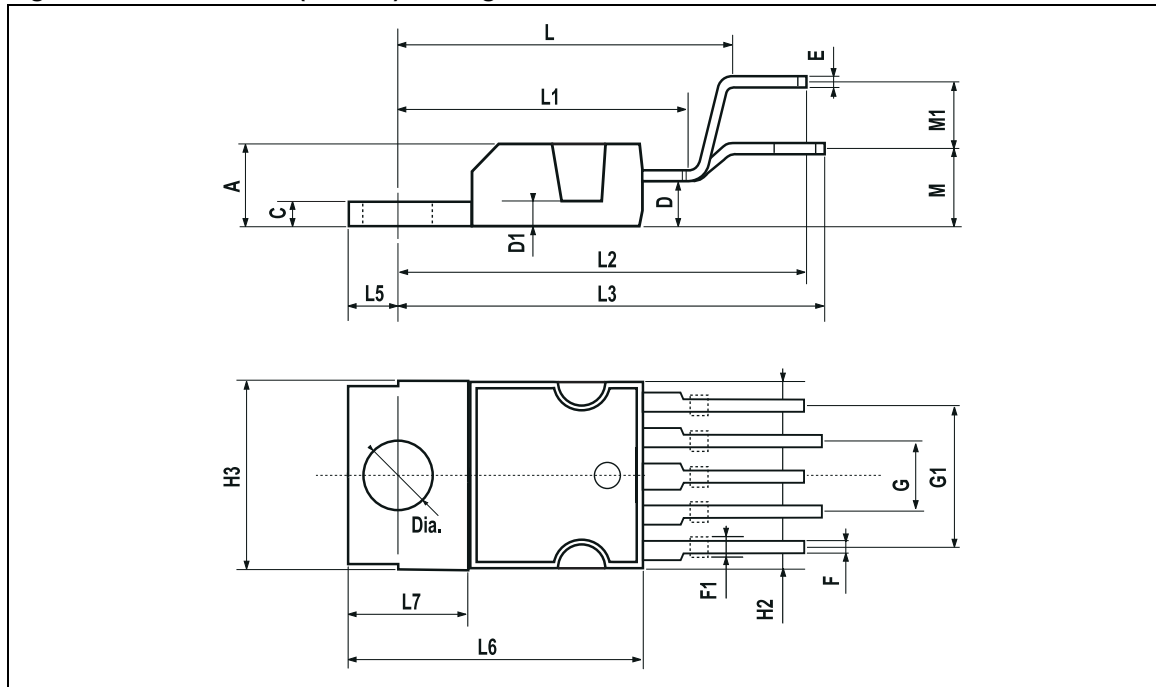


PACKAGE MECHANICAL

Table 10. PENTAWATT (vertical) Mechanical Data

Symbol	millimeters		
	Min	Typ	Max
A			4.8
C			1.37
D	2.4		2.8
D1	1.2		1.35
E	0.35		0.55
F	0.8		1.05
F1	1		1.4
G	3.2	3.4	3.6
G1	6.6	6.8	7
H2			10.4
H3	10.05		10.4
L2	23.05	23.4	23.8
L3	25.3	25.65	26.1
L5	2.6		3
L6	15.1		15.8
L7	6		6.6
Dia.	3.65		3.85

Figure 12. PENTAWATT (vertical) Package Dimensions

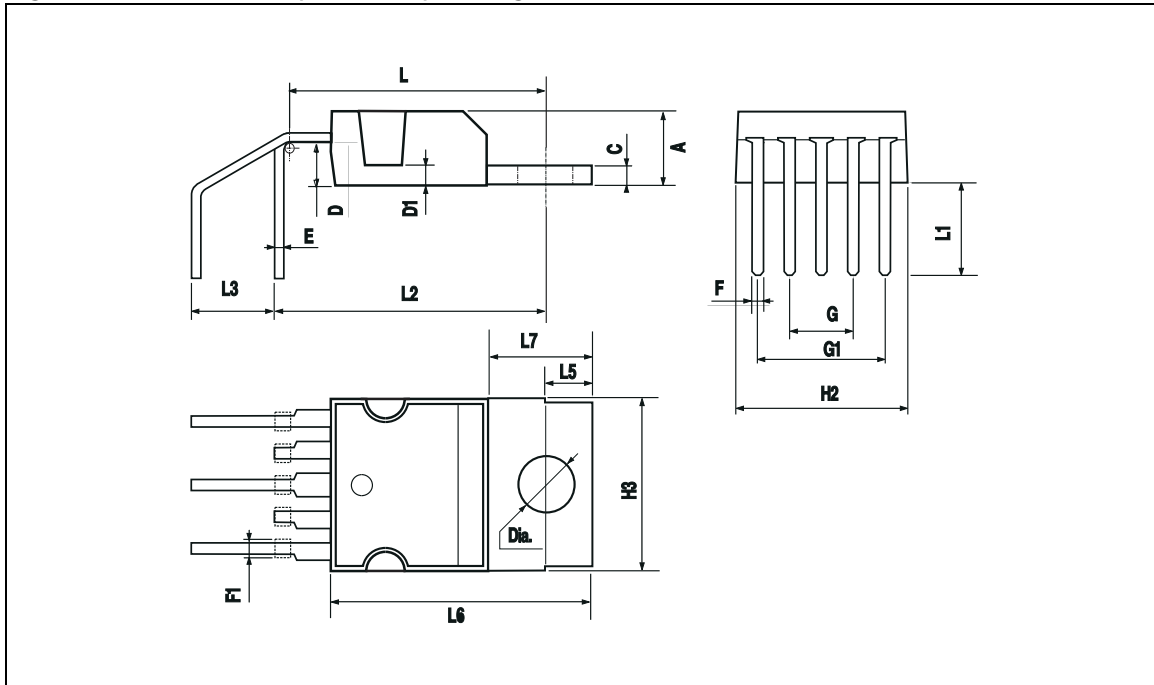


Note: Drawing is not to scale.

Table 11. PENTAWATT (horizontal) Mechanical Data

Symbol	millimeters		
	Min	Typ	Max
A			4.8
C			1.37
D	2.4		2.8
D1	1.2		1.35
E	0.35		0.55
F	0.8		1.05
F1	1		1.4
G	3.2	3.4	3.6
G1	6.6	6.8	7
H2			10.4
H3	10.05		10.4
L	14.2		15
L1	5.7		6.2
L2	14.6		15.2
L3	3.5		4.1
L5	2.6		3
L6	15.1		15.8
L7	6		6.6
Dia.	3.65		3.85

Figure 13. PENTAWATT (horizontal) Package Dimensions

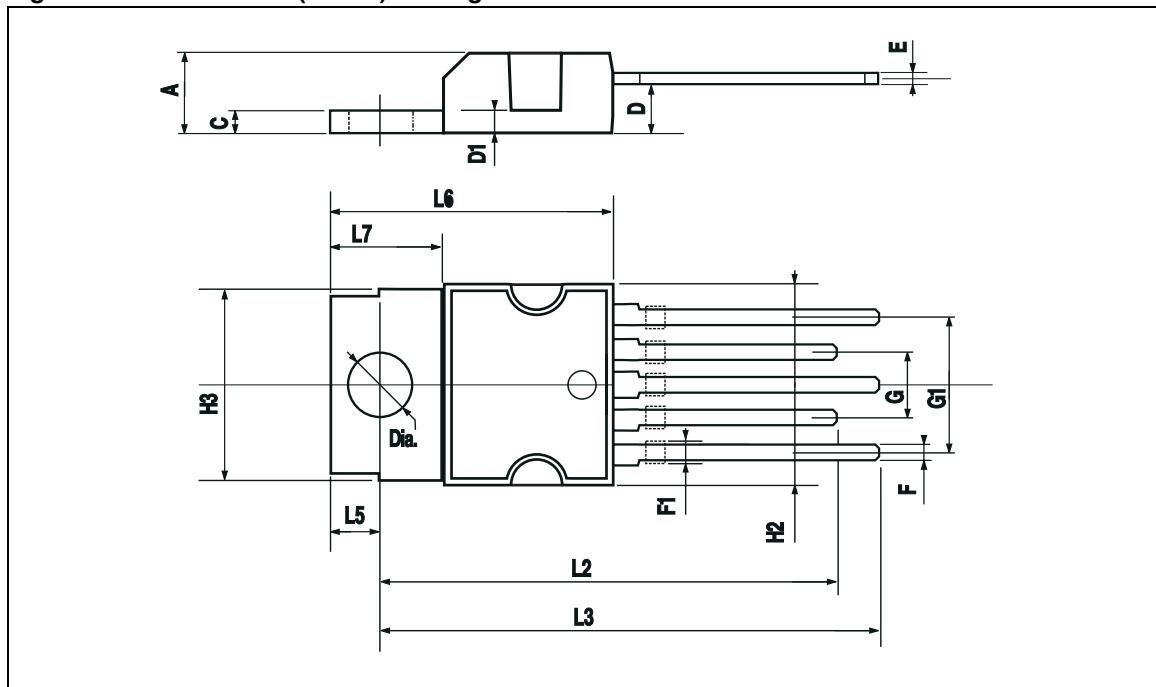


Note: Drawing is not to scale.

Table 12. PENTAWATT (in-line) Mechanical Data

Symbol	millimeters		
	Min	Typ	Max
A			4.8
C			1.37
D	2.4		2.8
D1	1.2		1.35
E	0.35		0.55
F	0.8		1.05
F1	1		1.4
G	3.2	3.4	3.6
G1	6.6	6.8	7
H2			10.4
H3	10.05		10.4
L2	23.05	23.4	23.8
L3	25.3	25.65	26.1
L5	2.6		3
L6	15.1		15.8
L7	6		6.6
Dia.	3.65		3.85

Figure 14. PENTAWATT (in-line) Package Dimensions



Note: Drawing is not to scale.

REVISION HISTORY**Table 13. Revision History**

Date	Revision	Description of Changes
September-1994	1	First Issue
18-June-2004	2	Stylesheet update. No content change.

Information furnished is believed to be accurate and reliable. However, STMicroelectronics assumes no responsibility for the consequences of use of such information nor for any infringement of patents or other rights of third parties which may result from its use. No license is granted by implication or otherwise under any patent or patent rights of STMicroelectronics. Specifications mentioned in this publication are subject to change without notice. This publication supersedes and replaces all information previously supplied. STMicroelectronics products are not authorized for use as critical components in life support devices or systems without express written approval of STMicroelectronics.

The ST logo is a registered trademark of STMicroelectronics.
All other names are the property of their respective owners

© 2004 STMicroelectronics - All rights reserved

STMicroelectronics GROUP OF COMPANIES

Australia - Belgium - Brazil - Canada - China - Czech Republic - Finland - France - Germany - Hong Kong - India - Israel - Italy - Japan -
Malaysia - Malta - Morocco - Singapore - Spain - Sweden - Switzerland - United Kingdom - United States

www.st.com