



## Smart Quad Channel Low-Side Switch

### Features

#### Product Summary

- Shorted Circuit Protection
- Overtemperature Protection
- Overvoltage Protection
- Parallel Control of the Inputs (PWM Applications)
- Seperate Diagnostic Pin for Each Channel
- Power - SO 20 - Package with integrated cooling area
- Standby mode with low current consumption
- $\mu$ C compatible Input
- Electrostatic Discharge (ESD) Protection
- Green Product (RoHS compliant)
- AEC qualified

Supply voltage	$V_S$	4.8 - 32 V
Drain source voltage	$V_{DS(AZ)max}$	60 V
On resistance	$R_{ON 1,2}$	0.23 $\Omega$
	$R_{ON 3,4}$	0.28 $\Omega$
Output current	$I_D 1,2 (max)$	2 x 5 A
	$I_D 3,4 (max)$	2 x 3 A



### Application

- All kinds of resistive and inductive loads (relays,electromagnetic valves)
- $\mu$ C compatible power switch for 12 and 24 V applications
- Solenoid control switch in automotive and industrial control systems
- Robotic Controls

### General description

Quad channel Low-Side-Switch (2x5A/2x3A) in Smart Power Technology (SPT) with four separate inputs and four open drain DMOS output stages. The TLE 6228 GP is fully protected by embedded protection functions and designed for automotive and industrial applications. Each channel has its own status signal for diagnostic feedback. Therefore the TLE 6228 GP is particularly suitable for ABS or Powertrain Systems.

### Block Diagram

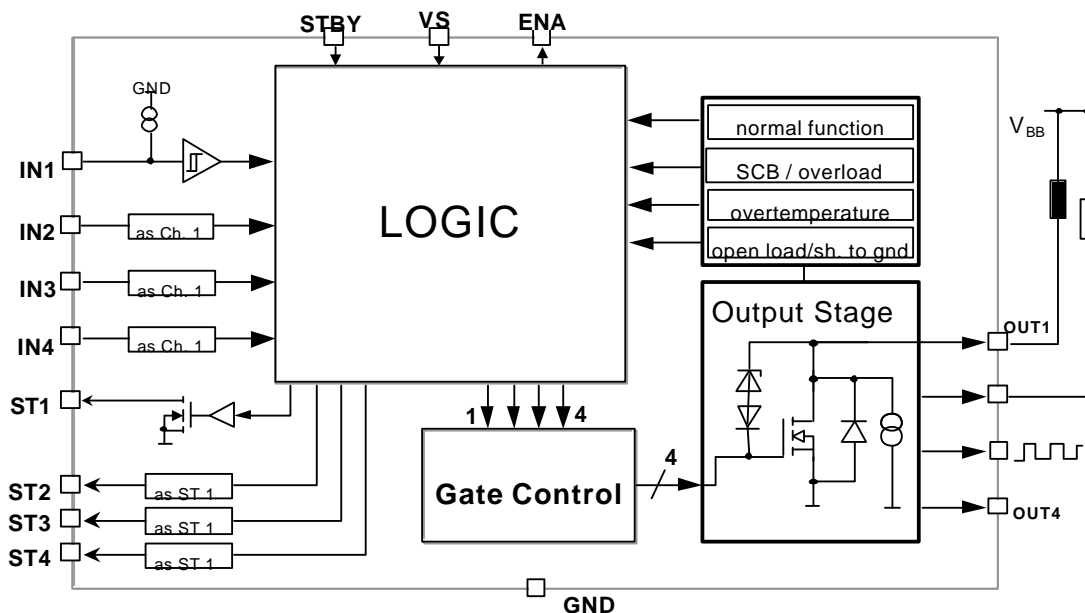

### Detailed Block Diagram

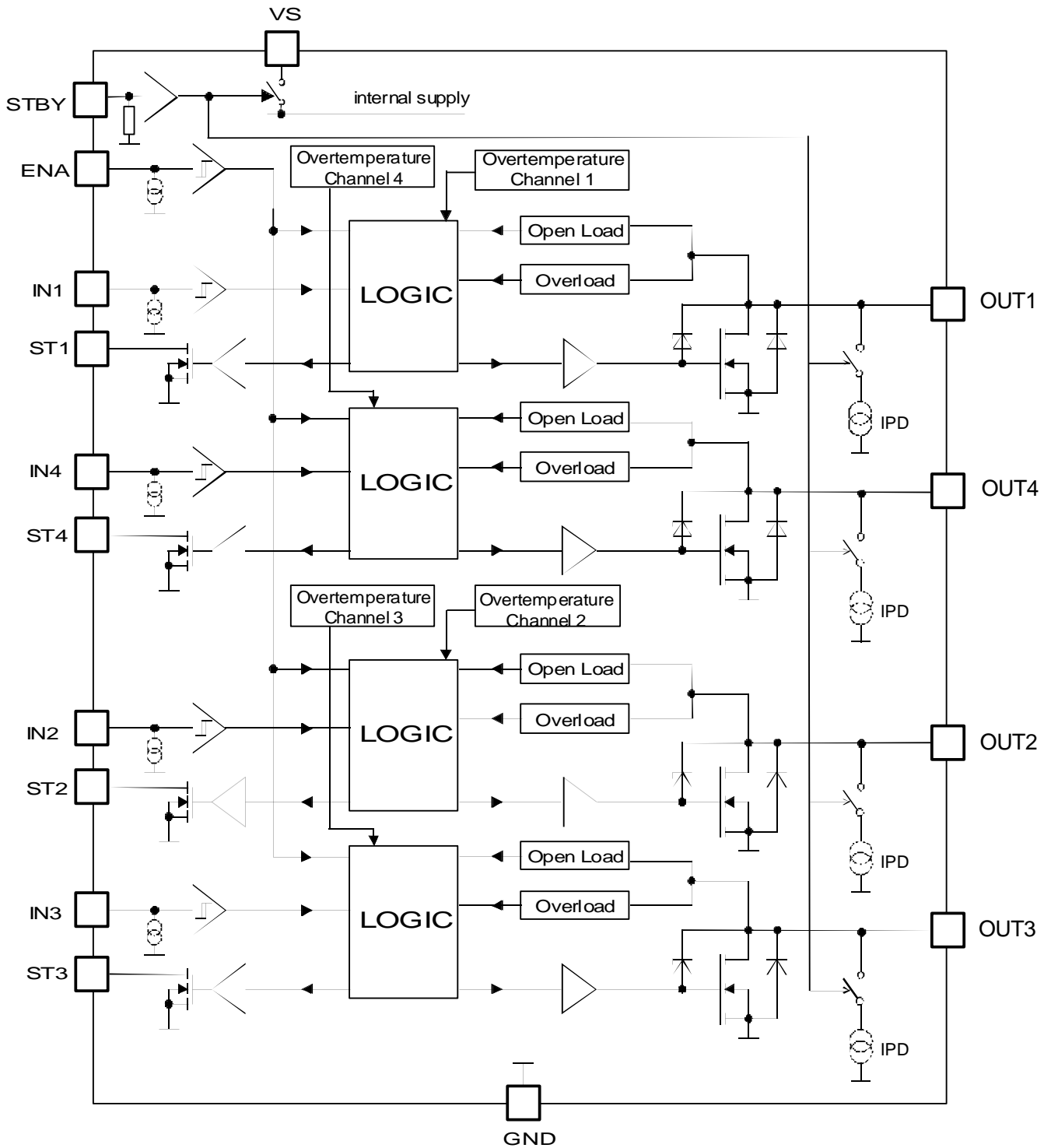

**Pin Description**

Pin	Symbol	Function
1	GND	Ground
2	OUT1	Power Output channel 1
3	ST1	Status Output channel 1
4	IN4	Control Input channel 4
5	VS	Supply Voltage
6	STBY	Standby
7	IN3	Control Input channel 3
8	ST2	Status Output channel 2
9	OUT2	Power Output channel 2
10	GND	Ground
11	GND	Ground
12	OUT3	Power Output channel 3
13	ST3	Status Output channel 3
14	IN2	Control Input channel 2
15	GND	Ground Logic
16	ENA	Enable Input for all four channels
17	IN1	Control Input channel 1
18	ST4	Status Output channel 4
19	OUT4	Power Output channel 4
20	GND	Ground

**Pin Configuration (Top view)**

GND	1 ●	20	GND
OUT1	2	19	OUT4
ST1	3	18	ST4
IN4	4	17	IN1
VS	5	16	ENA
STBY	6	15	GNDL
IN3	7	14	IN2
ST2	8	13	ST3
OUT2	9	12	OUT3
GND	10	11	GND

PG - DSO - 20 - 65

Heat slug internally connected to ground pins

**Maximum Ratings for  $T_j = -40^{\circ}\text{C}$  to  $150^{\circ}\text{C}$** 

The maximum ratings may not be exceeded under any circumstances, not even momentarily and individually, as permanent damage to the IC will result.

Parameter	Symbol	Values	Unit
Supply voltage	$V_S$	-0.3 ... + 40	V
Continuous drain source voltage (OUT1...OUT4)	$V_{DS}$	45	V
Input voltage IN1 to IN4, ENA	$V_{IN}, V_{ENA}$	- 0.3 ... + 6	V
Input voltage STBY	$V_{STBY}$	- 0.3 ... + 40	
Status output voltage	$V_{ST}$	- 0.3 ... + 32	V
Load Dump Protection $V_{Load\ Dump} = U_P + U_S$ ; $U_P = 13.5\text{ V}$ $R_l^1) = 2\ \Omega$ ; $t_d = 400\text{ms}$ ; IN = low or high With $R_L = 5\ \Omega$ for Ch. 1,2; $10\ \Omega$ for Ch. 3,4 ( $I_D = 2,7\text{A}$ respectively $1,35\text{A}$ )	$V_{Load\ Dump}^{2)}$	55	V
Operating temperature range	$T_j$	- 40 ... + 150	$^{\circ}\text{C}$
Storage temperature range	$T_{stg}$	- 55 ... + 150	
Output current per channel (see page 6)	$I_{D(lim)}$	$I_{D(lim)\ min}$	A
Status output current	$I_{ST}$	- 5 ... + 5	mA
Inductive load switch off energy (single pulse) $T_j = 25^{\circ}\text{C}$	$E_{AS}$	50	mJ
Electrostatic Discharge Voltage (human body model) according to MIL STD 883D, method 3015.7 and EOS/ESD assn. standard S5.1 - 1993	$V_{ESD}$	2000	V
DIN Humidity Category, DIN 40 040		E	
IEC Climatic Category, DIN IEC 68-1		40/150/56	
Thermal resistance			K/W
junction – case (die soldered on the frame)	$R_{thJC}$	2	
junction - ambient @ min. footprint	$R_{thJA}$	50	
junction - ambient @ $6\text{ cm}^2$ cooling area		38	

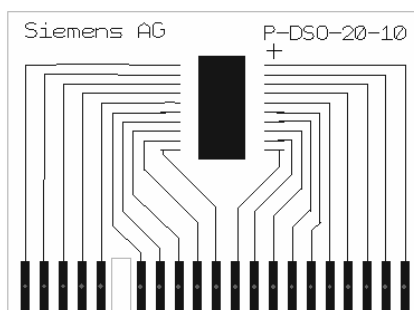

Minimum footprint

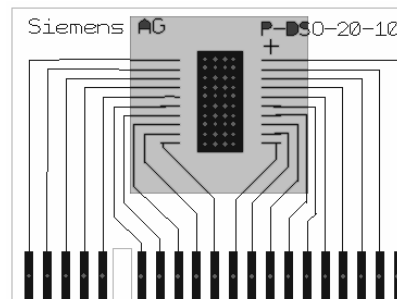
 PCB with heat pipes,  
backside  $6\text{ cm}^2$  cooling area

<sup>1)</sup>  $R_l$  = internal resistance of the load dump test pulse generator LD200

<sup>2)</sup>  $V_{LoadDump}$  is setup without DUT connected to the generator per ISO 7637-1 and DIN 40 839.

**Electrical Characteristics**

Parameter and Conditions $V_S = 4.8$ to $18$ V ; $T_j = -40$ °C to $+150$ °C (unless otherwise specified)	Symbol	Values			Unit
		min	typ	max	

**1. Power Supply ( $V_S$ )**

Supply current (Outputs ON)	$I_S$			8	mA
Supply current (Outputs OFF) $V_{ENA} = L, V_{STBY} = H$	$I_S$			4	mA
Standby current $V_{STBY} = L$	$I_S$			10	$\mu$ A
Operating voltage	$V_S$	4.8		32	V

**2. Power Outputs**

ON state resistance Channel 1,2 $I_D = 1$ A; $V_S \geq 9.5$ V	$T_j = 25$ °C $T_j = 150$ °C	$R_{DS(ON)}$		0.23 0.26	0.26 0.5	$\Omega$
ON state resistance Channel 3,4 $I_D = 1$ A; $V_S \geq 9.5$ V	$T_j = 25$ °C $T_j = 150$ °C	$R_{DS(ON)}$		0.28	0.4 0.75	$\Omega$
Z-Diode clamping voltage (OUT1...4) $I_D \geq 100$ mA		$V_{DS(AZ)}$	45		60	V
Pull down current $V_{STBY} = H, V_{IN} = L$		$I_{PD}$	10	20	50	$\mu$ A
Output leakage current <sup>3</sup> $V_{STBY} = L, 0V \leq V_{DS} \leq 20V$		$I_{DIK}$			5	$\mu$ A
Output turn on time <sup>4</sup> $I_D = 1$ A		$t_{on}$	3	15	50	$\mu$ s
Output turn off time <sup>4</sup> $I_D = 1$ A		$t_{off}$	3	20	60	
Output on fall time <sup>4</sup> $I_D = 1$ A		$t_{fall}$	3	10	30	
Output off rise time <sup>4</sup> $I_D = 1$ A		$t_{rise}$	3	5	30	
Overload switch-off delay time <sup>4</sup>		$t_{DSO}$	20	60	100	
Output off status delay time <sup>4</sup>		$t_D$	500	1200	3000	
Failure extension Time for Status Report		$t_{D-failure}$	500	1200	3000	
Input Suppression Time		$t_{D-IN}$	500	1200	3000	
Open Load (off) filtering Time <sup>5</sup>		$t_{fOL(off)}$	10	30	100	

**3. Digital Inputs (IN1, IN2, IN3, IN4, ENA)**

Input low voltage	$V_{INL}$	- 0.3		1.0	V
Input high voltage	$V_{INH}$	2.0		6.0	V
Input voltage hysteresis <sup>5</sup>	$V_{INHys}$	50	200		mV
Input pull down current $V_{IN} = 5$ V; $V_S \geq 6.5$ V	$I_{IN}$	10	30	60	$\mu$ A
Enable pull down current $V_{ENA} = 5$ V; $V_S \geq 6.5$ V	$I_{ENA}$	10	20	40	$\mu$ A

**4. Digital Status Outputs (ST1 - ST4) Open Drain**

Output voltage low $I_{ST} = 2$ mA	$V_{STL}$			0.5	V
Leakage current high	$I_{STH}$			2	$\mu$ A

<sup>3</sup> If the output voltage exceeds 35V, this current (zener current of a internal structure) can rise up to 1mA

<sup>4</sup> See timing diagram, resistive load condition;  $V_S \geq 9$  V

<sup>5</sup> This parameter will not be testet but assured by design

**Electrical Characteristics**

Parameter and Conditions $V_S = 4.8$ to $18$ V ; $T_j = -40$ °C to $+150$ °C (unless otherwise specified)	Symbol	Values			Unit
		min	typ	max	

**5. Standby Input (STBY)**

Input low voltage	$V_{STBY}$	0		1	V
Input high voltage	$V_{STBY}$	3.5		$V_S$	V
Input current $V_{STBY} = 18$ V	$I_{STBY}$			300	$\mu$ A

**6. Diagnostic Functions**

Open load detection voltage $V_{ENA} = X, V_{IN} = L$	$V_S \geq 6.5$ V	$V_{DS(OL)}$	$0.3 \cdot V_S$	$0.33 \cdot V_S$	$0.36 \cdot V_S$	V
Open load detection current channel 1,2 $V_{ENA} = V_{IN} = H$	$V_S \geq 6.5$ V	$I_{D(OL) 1,2}$	100	160	250	mA
Open load detection current channel 3,4 $V_{ENA} = V_{IN} = H$	$V_S \geq 6.5$ V	$I_{D(OL) 3,4}$	100	160	250	mA
Overload detection current channel 1,2	$V_S \geq 6.5$ V	$I_{D(lim) 1,2}$	5	7.5		A
Overload detection current channel 3,4	$V_S \geq 6.5$ V	$I_{D(lim) 3,4}$	3	5.5		A
Overtemperature shutdown threshold <sup>5</sup>		$T_{th}$	170		200	°C
Hysteresis		$T_{hys}$		10		K
Pulse Width for static diagnostic output		$t_{IN}$			500	$\mu$ s

<sup>5</sup> This parameter will not be tested but assured by design

## Application Description

This IC is especially designed to drive inductive loads (relays, electromagnetic valves). Integrated clamp-diodes limit the output voltage when inductive loads are discharged.

Four open-drain logic outputs indicate the status of the integrated circuit. The following conditions are monitored and signalled:

- overloading of output (also shorted load to supply) in active mode
- open and shorted load to ground in active and inactive mode
- overtemperature

## Circuit Description

### Input Circuits

The control and enable inputs, both active high, consist of schmitt triggers with hysteresis. All inputs are provided with pull-down current sources. Not connected inputs are interpreted as low and the respective output stages are switched off.

In standby mode (STBY = LOW ) the current consumption is greatly reduced.

The circuit is active when STBY = HIGH.

If the standby function is not used, it is allowed to connect the standby pin directly to VS.

Status Signals: The status signals are undefined for 2ms after a power up event or a STBY low to high transition.

### Output Stages

The four power outputs consist of DMOS-power transistors with open drains. The output stages are short circuit protected throughout the operating range. Each output has its own zenerclamp. This causes a voltage limitation at the power transistor when inductive loads are switched off.

Parallel to the DMOS transistors there are internal pull down current sources. They are provided to detect an open load condition in the off state. They will be disconnected in the standby mode.

Due to EMI measures there is an internal zenerclamp in parallel to the output stage. It gets active above 33V drain source voltage. This leads to an increasing leakage current up to 1 mA @  $V_{DS} = 40V$ .

### Protective Circuits

The outputs are protected<sup>6)</sup> against current overload and overtemperature. If the output current increases above the overload detection threshold  $I_{BO}$  for a longer time than  $t_{BSO}$  or the temperature increases above  $T_{th}$ , then the power transistor is immediately switched off. It remains off until the control signal at the input is switched off and on again.

### Fault Detection

The status outputs indicate the switching state of the output stage. Under normal conditions is: ST = low  $\Rightarrow$  Output off; ST = high  $\Rightarrow$  Output on. If an error occurs, the logic level of the status output is inverted, as listed in the diagnostic table.

---

<sup>6)</sup> The integrated protection functions prevent an IC destruction under fault conditions and may not be used in normal operation or permanently.

If current overload or overtemperature occurs for a longer time than  $t_{DSO}$ , the fault condition is latched into an internal register and the output is shutdown. The reset is done by switching off the corresponding control input for a time longer than  $t_{D-IN}$ .

Open load is detected for all four channels in on and off mode.

In the on mode the load current is monitored. If it drops below the specified threshold value  $I_{QU}$  then an open load condition is detected.

In the off mode, the output voltage is monitored. An open load condition is detected when the output voltage of a given channel is below the threshold  $V_{DS(OL)}$ , which is typ. 33 % of the supply voltage  $V_S$ . To prevent an open load diagnosis in case of transient Voltages on the outputs the open load detection in off mode uses a filter of typ. 50 $\mu$ s.

### Status output at pulse width operation

If the input is operated with a pulsed signal, the status does not follow each single pulse of the input signal. An internal delay  $t_D$  of typ. 1.2ms ( min 500  $\mu$ s) enables a continuous status output signal. See the timing diagrams on the following pages for further information.

This internal status delay simplifies diagnostic software for pwm applications.

## Diagnostic Table

In general the status follows the input signal in normal operating conditions.

If any error is detected the status is inverted.

Operating Condition	Standby Input	Enable Input	Control Input	Power Output	Status Output
	STBY	ENA	IN	Q	ST
Standby <sup>1)</sup>	L	X	X	off	H
Normal function	H	L	X	off	L
	H	H	L	off	L
	H	H	H	ON	H
Open load or short to ground	H	L	L	off	H
	H	L	H	off	H
	H	H	L	off	H
	H	H	H	ON	L
Overload or short to supply <sup>2)</sup> reset latch <sup>3)</sup>	H	H	H	off	L
	H	H	H $\rightarrow$ L	off	L
	H	L	X	off	L
Overtemperature <sup>2)</sup> reset latch <sup>3)</sup>	H	H	H	off	L
	H	H	H $\rightarrow$ L	off	L
	H	L	X	off	L



Note 1) : Standby is not designed for switching or PWM operation of the outputs

Note 2) : overload/short-to-supply/overtemperature - events shorter than min. time  $t_{D-ISO}$  specified in 2.10 will not be latched and not reported at the status pin.

Note 3) : to reset latched status-output in case of overload/short-to-supply/overtemperature the control input has to go low and stay low for longer than max. input suppression time  $t_{D-IN}$  specified in 2.13 of the characteristics

## Failure Situations and Status Report

### Logic Block Diagram

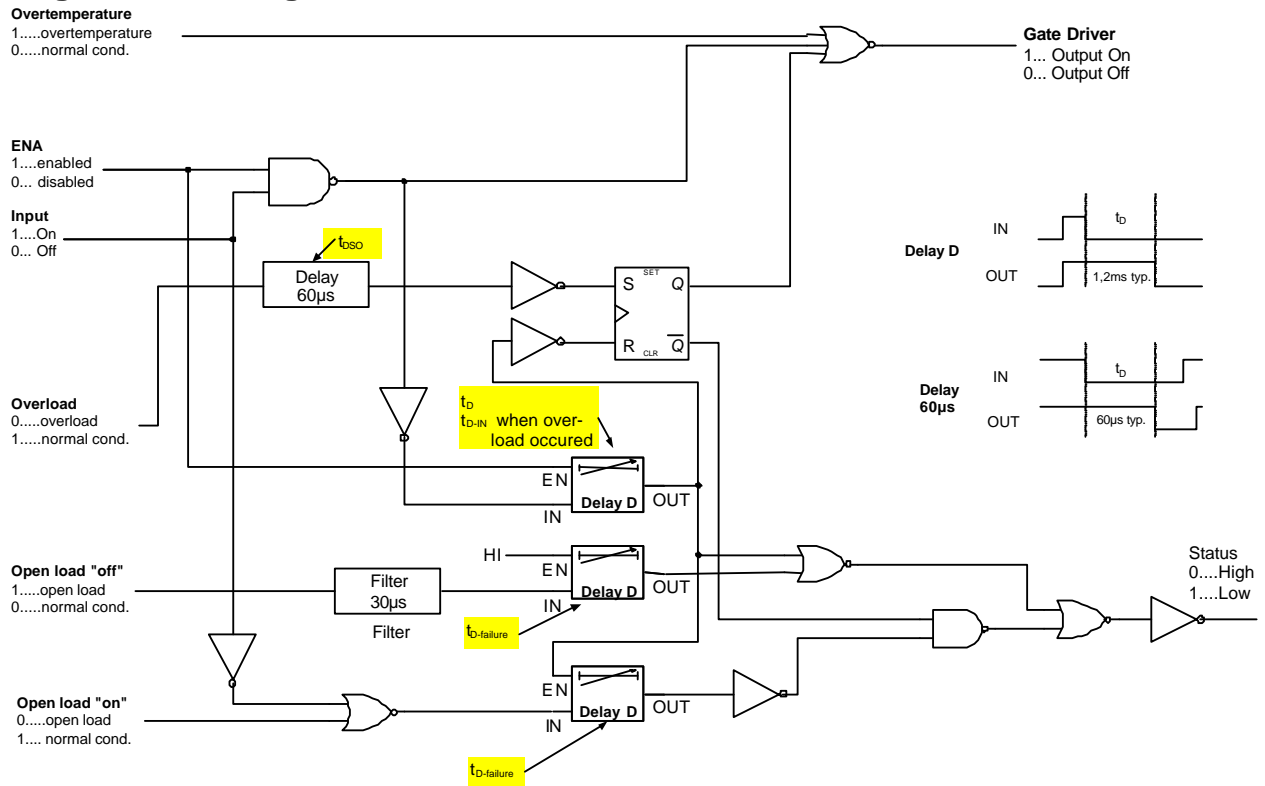

## Timing Diagrams

### Output Slope

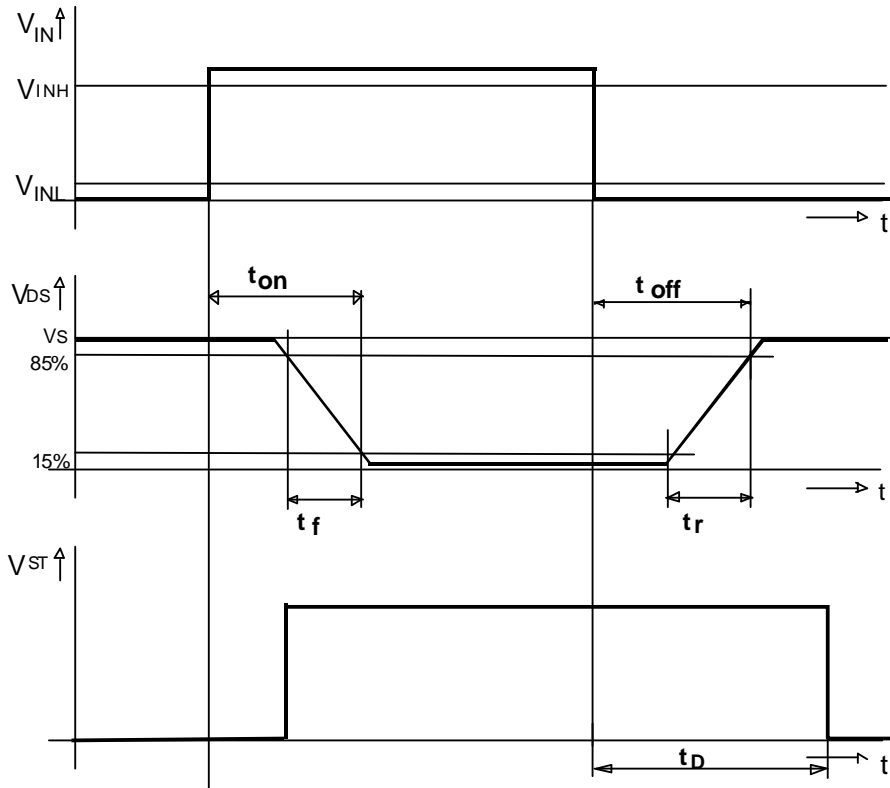

Fig. 1

### Overload Switch OFF Delay

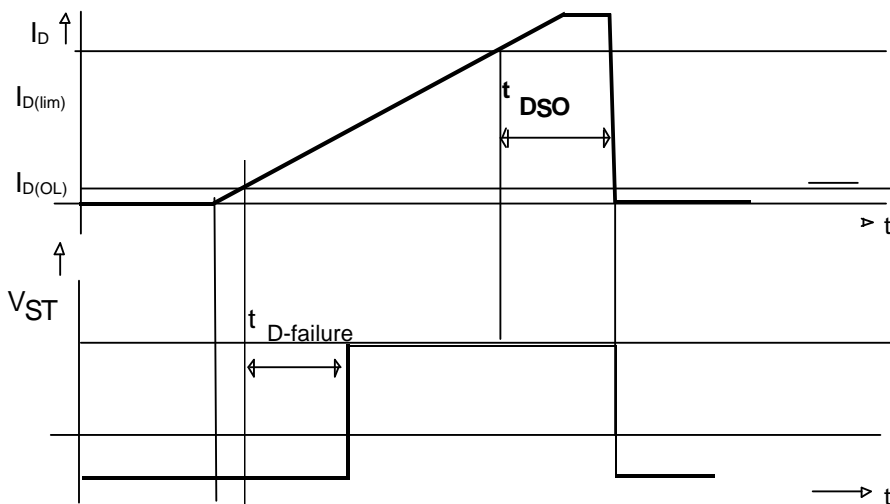
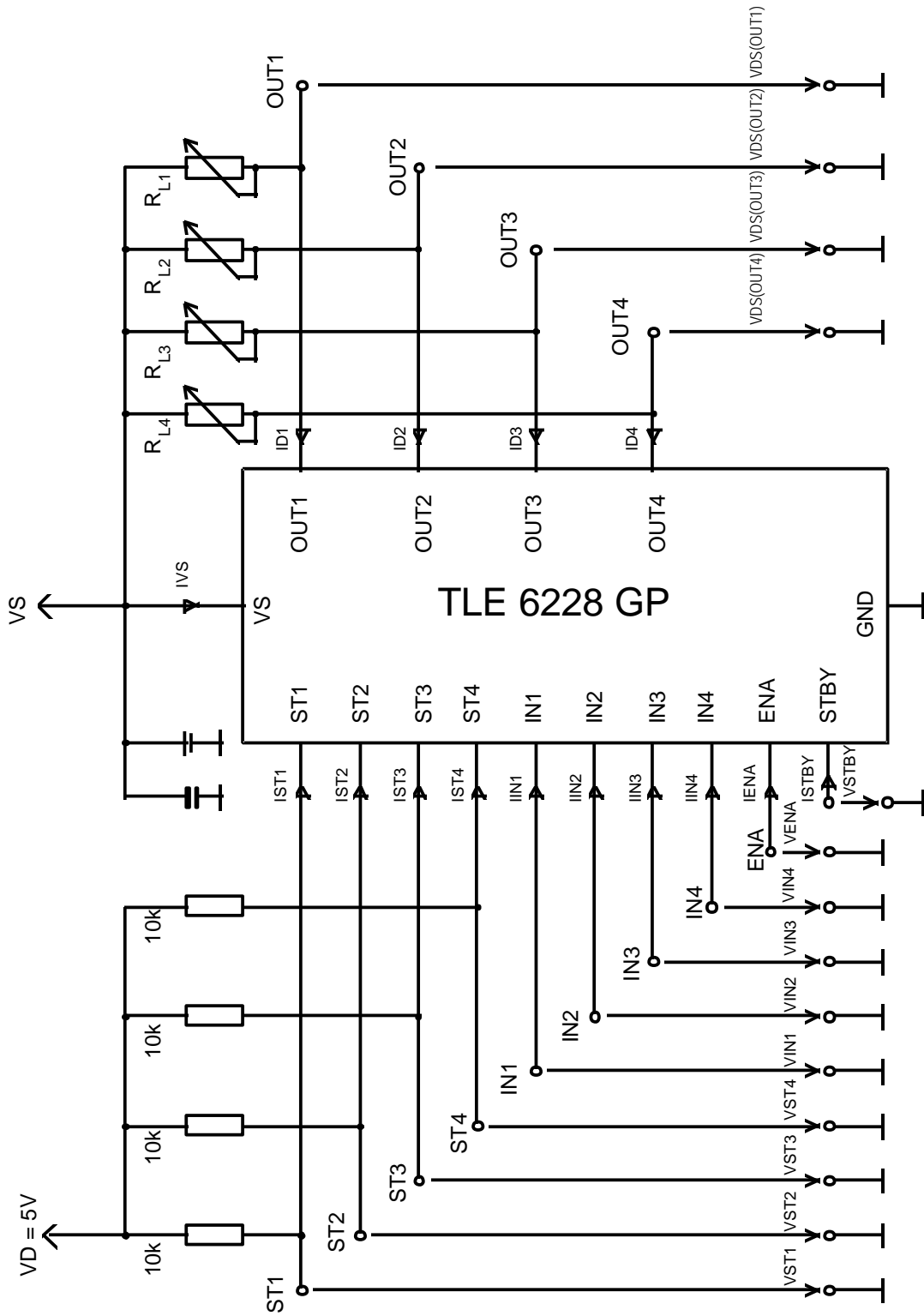
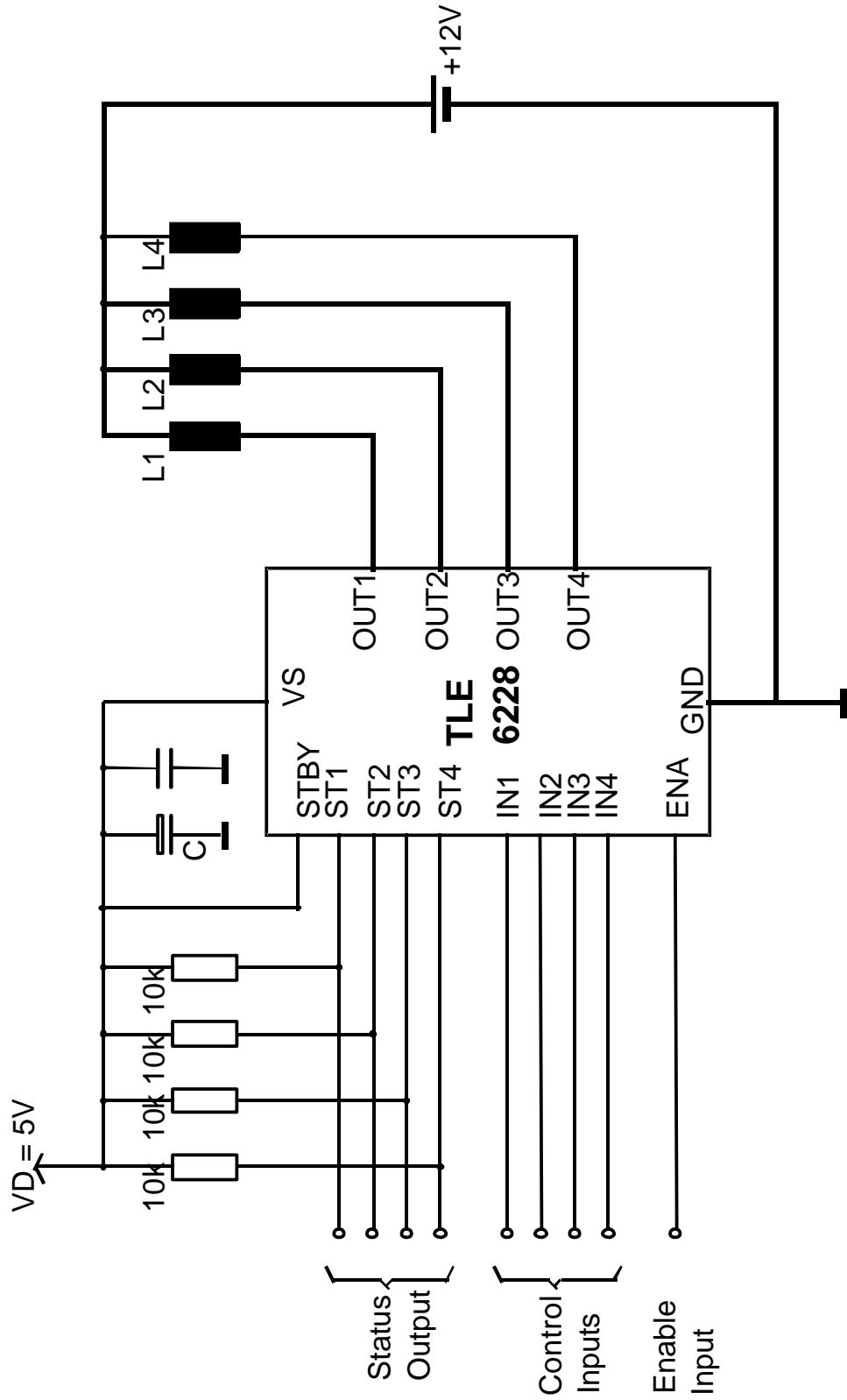

Fig. 2

**Test Circuit**



**Application Circuit**



The blocking capacitor C is recommended to avoid critical negative voltage spikes on VS in case of battery interruption during OFF-commutation.

### Timing Diagrams of Diagnostic with Pulsed Input Signal

#### Normal condition, resistive load, pulsed input signal

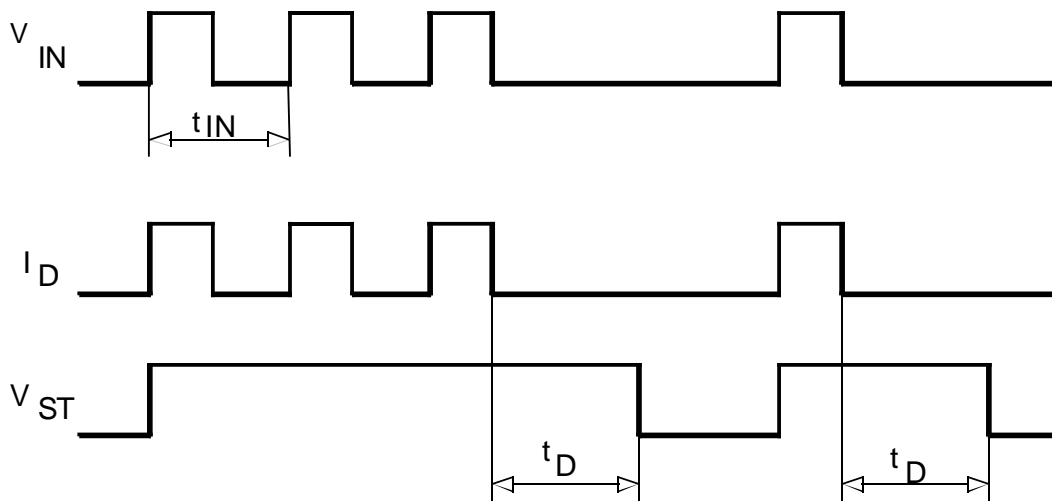
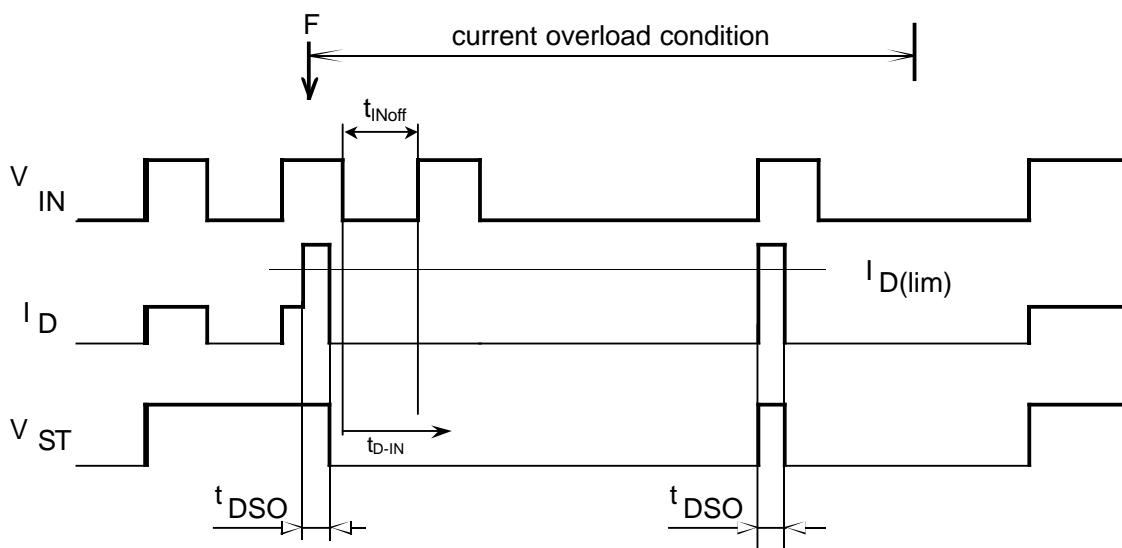

Fig. 3

#### Current Overload



$t_{INoff} < t_{D-IN}$  : Input suppression time avoids a restart after overtemperature

Fig. 4

Diagnostic status output at different open load current conditions

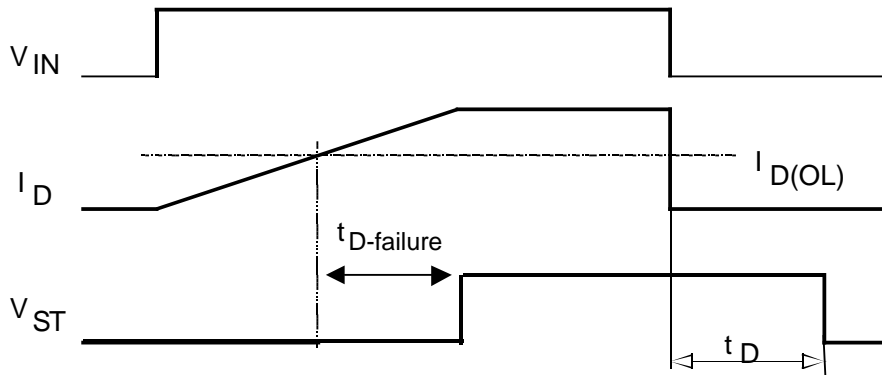
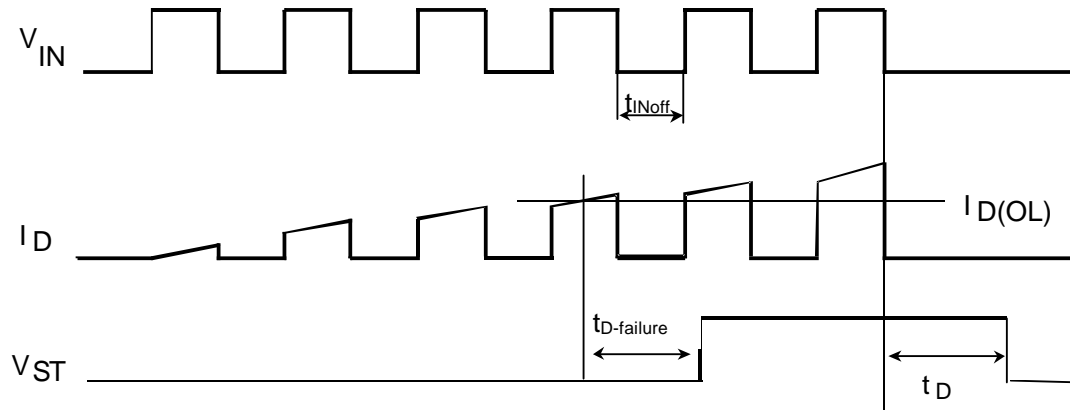
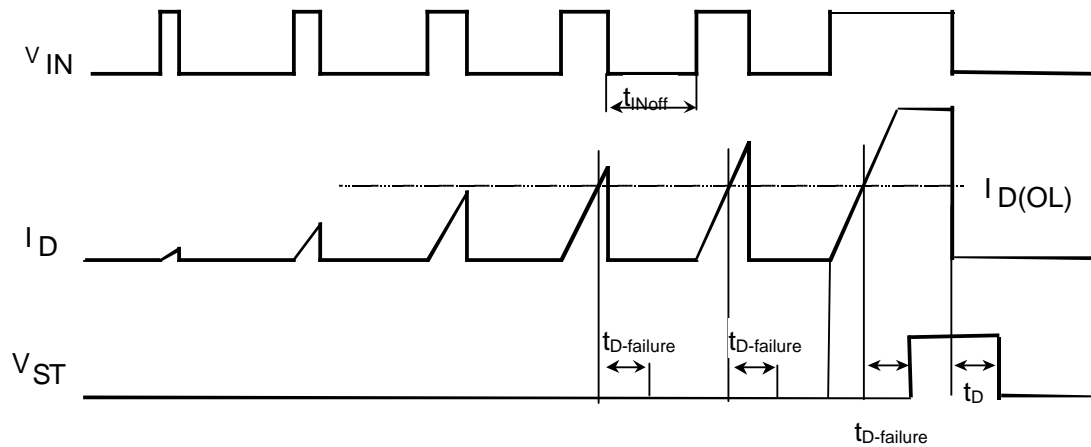

Fig. 5



$t_{INOFF} < t_D$  leads to a static status signal

Fig. 6



$t_{INOFF} > t_D$  : Intermittent status signal

Fig. 7

**Normal operation, followed by open load condition**

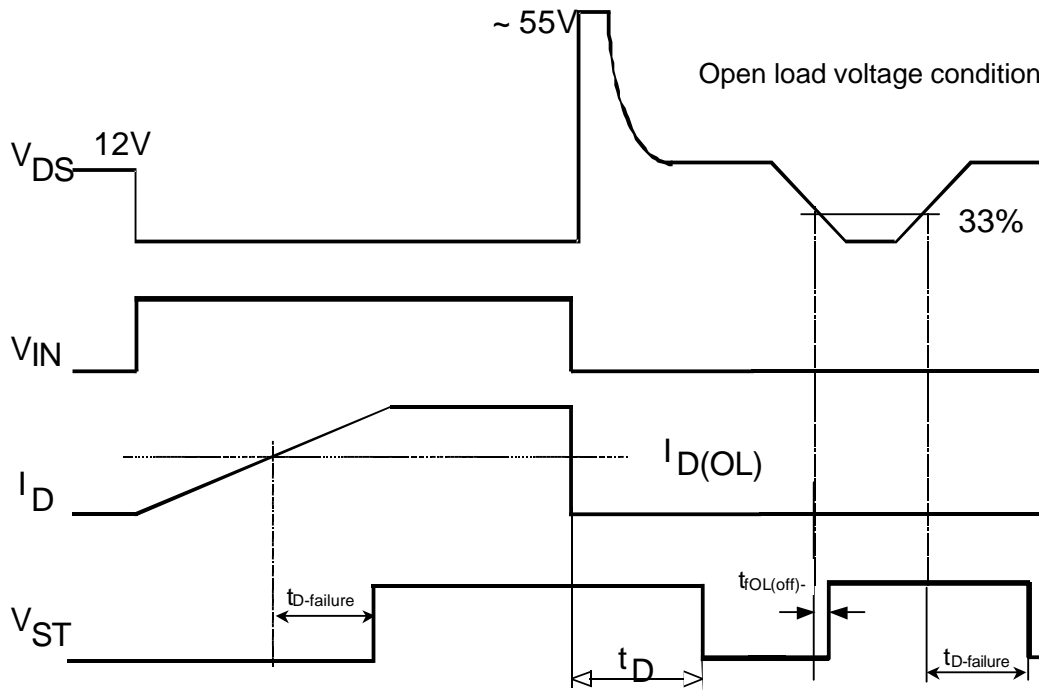

Fig. 8

**Overtemperature**

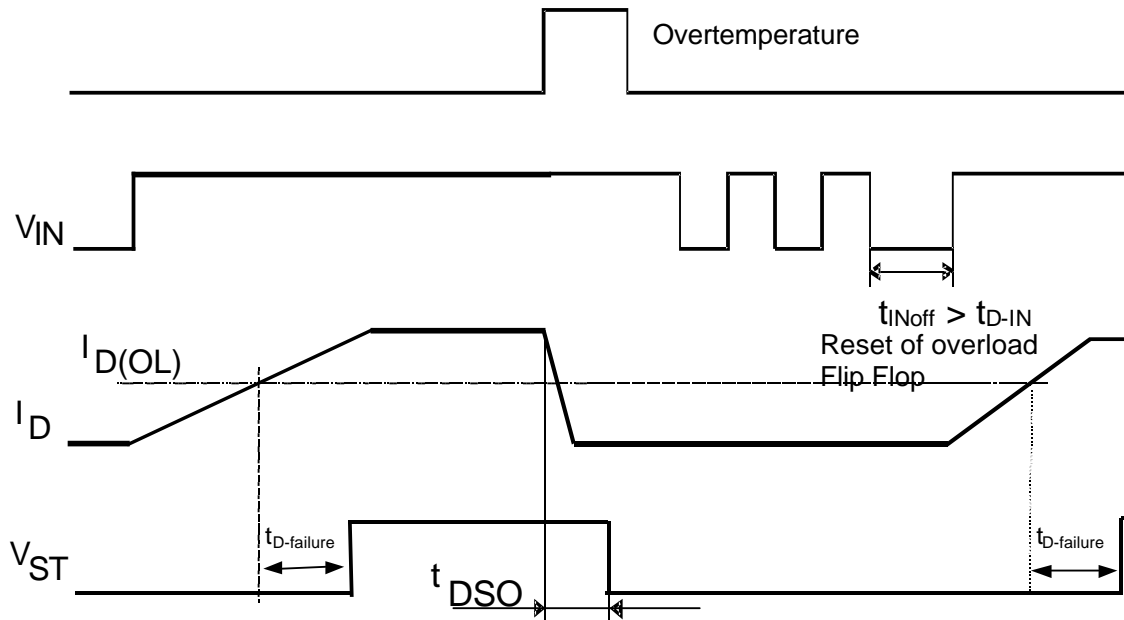

Fig. 9

## Typical electrical Characteristics

### Drain-Source on-resistance

$$R_{DS(ON)} = f(T_j) ; V_s = 9,5V$$

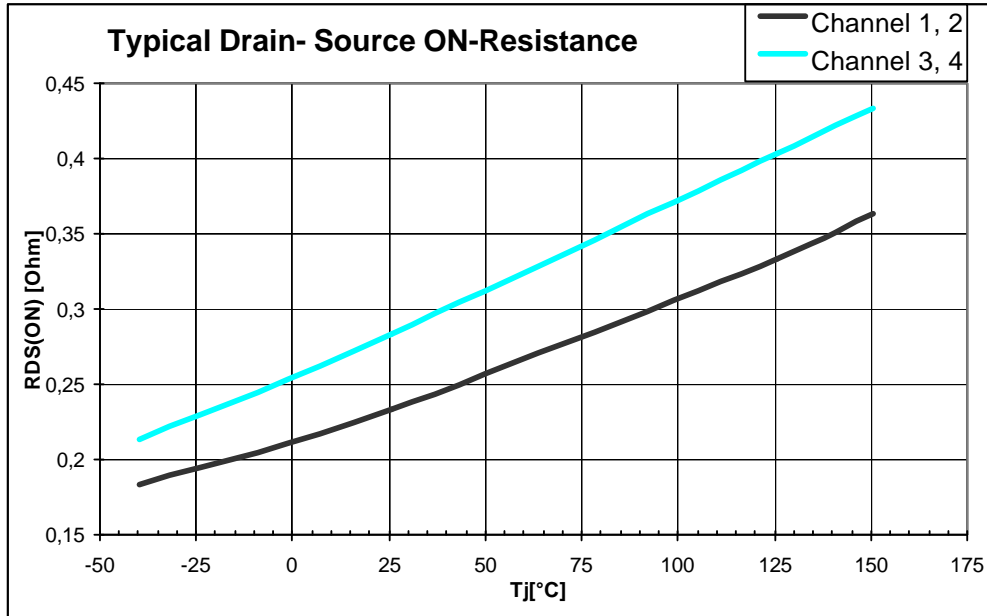

Figure 6 : Typical ON Resistance versus Junction-Temperature Channel 1-4

### Output Clamping Voltage

$$V_{DS(AZ)} = f(T_j) ; I_D = 100mA$$

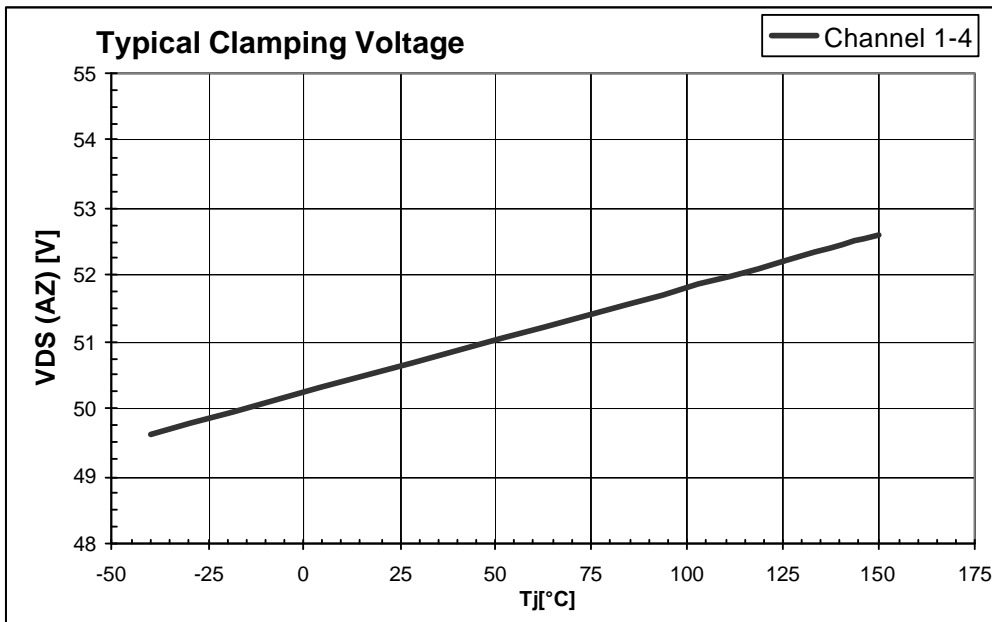
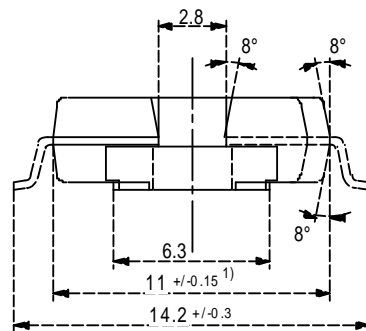
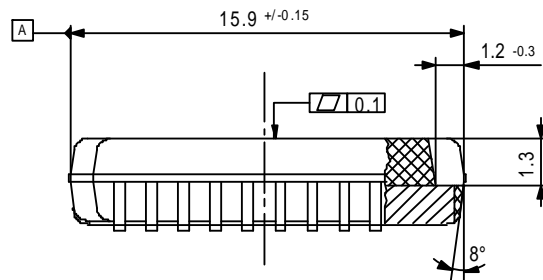
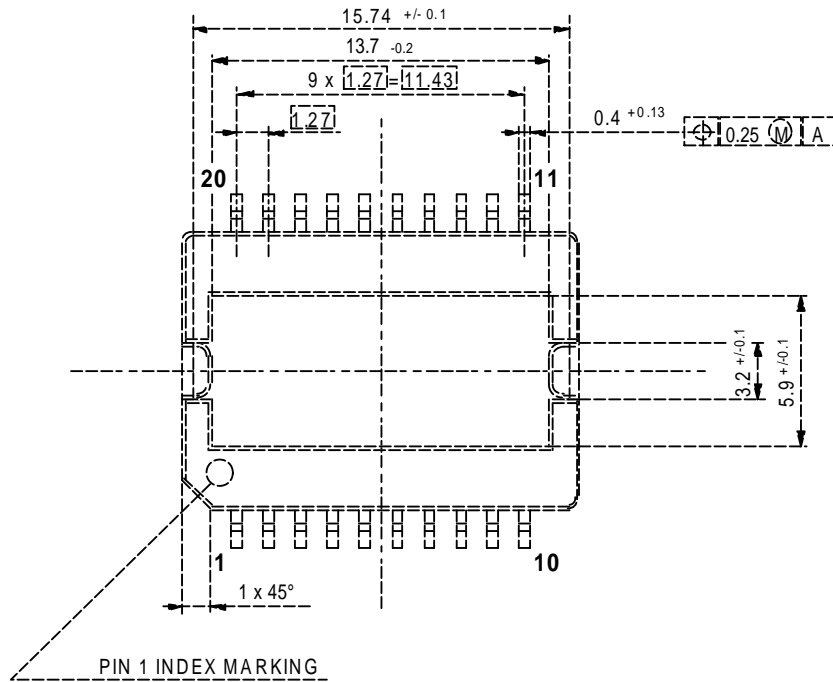

Figure 7 : Typical Clamp Voltage versus Junction-Temperature Channel 1-4



### Package

all dimensions in mm PG - DSO - 20 - 65



#### Green Product (RoHS compliant)

To meet the world-wide customer requirements for environmentally friendly products and to be compliant with government regulations the device is available as a green product. Green products are RoHS-Compliant (i.e Pb-free finish on leads and suitable for Pb-free soldering according to IPC/JEDEC J-STD-020).

## Revision History

Version	Date	Changes
V3.2 → V4.0: 2007-06-06: Version Change to Green Product		
V4.0	2007-06-06	Revision history implemented
V4.0	2007-06-06	IFX Logo updated
V4.0	2007-06-06	Package name according green nomenclature changed from <b>P-DSO-20-12</b> to <b>PG-DSO-20-37</b>
V4.0	2007-06-06	Ordering Code removed
V4.0	2007-06-06	Package Picture in front page up-dated
V4.0	2007-06-06	Added in feature list: <ul style="list-style-type: none"><li>• Green Product (RoHS compliant)</li><li>• AEC qualified</li></ul>
V4.0	2007-06-11	Green and AEC logo added
V4.0	2007-06-11	Disclaimer re-newed
V4.1	2010-07-10	Due to Cu wire bonding, package name changed from <b>PG-DSO-20-37</b> to <b>PG-DSO-20-65</b>

**Edition 2010-07-10**

**Published by**  
**Infineon Technologies AG**  
**81726 Munich, Germany**  
**© 2010 Infineon Technologies AG**  
**All Rights Reserved.**

#### **Legal Disclaimer**

The information given in this document shall in no event be regarded as a guarantee of conditions or characteristics. With respect to any examples or hints given herein, any typical values stated herein and/or any information regarding the application of the device, Infineon Technologies hereby disclaims any and all warranties and liabilities of any kind, including without limitation, warranties of non-infringement of intellectual property rights of any third party.

#### **Information**

For further information on technology, delivery terms and conditions and prices, please contact the nearest Infineon Technologies Office ([www.infineon.com](http://www.infineon.com)).

#### **Warnings**

Due to technical requirements, components may contain dangerous substances. For information on the types in question, please contact the nearest Infineon Technologies Office.

Infineon Technologies components may be used in life-support devices or systems only with the express written approval of Infineon Technologies, if a failure of such components can reasonably be expected to cause the failure of that life-support device or system or to affect the safety or effectiveness of that device or system. Life support devices or systems are intended to be implanted in the human body or to support and/or maintain and sustain and/or protect human life. If they fail, it is reasonable to assume that the health of the user or other persons may be endangered.