

Smart High-Side Power Switch

Two Channels: 2 x 40mΩ

Status Feedback

Product Summary

Operating Voltage	$V_{bb(on)}$	4.75...41V	
	Active channels	one	two parallel
On-state Resistance	R_{ON}	40mΩ	20mΩ
Nominal load current	$I_{L(NOM)}$	4.8A	7.3A
Current limitation	$I_{L(SCr)}$	30A	30A

Package

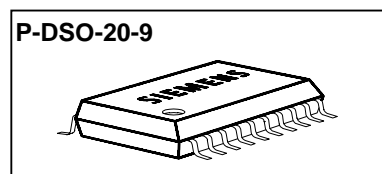

General Description

- N channel vertical power MOSFET with charge pump, ground referenced CMOS compatible input and diagnostic feedback, monolithically integrated in Smart SIPMOS® technology.
- Providing embedded protective functions

Applications

- μ C compatible high-side power switch with diagnostic feedback for 5V, 12V and 24V grounded loads
- All types of resistive, inductive and capacitive loads
- Most suitable for loads with high inrush currents, so as lamps
- Replaces electromechanical relays, fuses and discrete circuits

Basic Functions

- Very low standby current
- CMOS compatible input
- Fast demagnetization of inductive loads
- Stable behaviour at undervoltage
- Wide operating voltage range
- Logic ground independent from load ground

Protection Functions

- Short circuit protection
- Overload protection
- Current limitation
- Thermal shutdown
- Overvoltage protection (including load dump) with external resistor
- Reverse battery protection with external resistor
- Loss of ground and loss of V_{bb} protection
- Electrostatic discharge protection (ESD)

Diagnostic Function

- Diagnostic feedback with open drain output
- Open load detection in ON-state
- Feedback of thermal shutdown in ON-state

Block Diagram

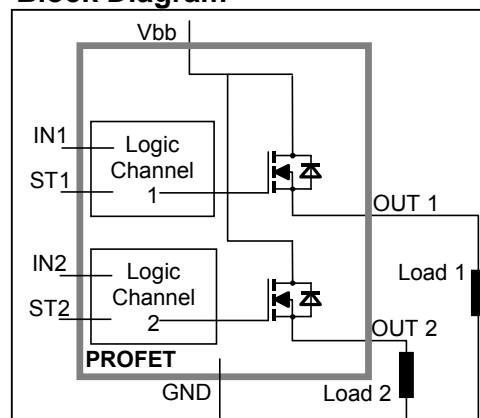

Functional diagram

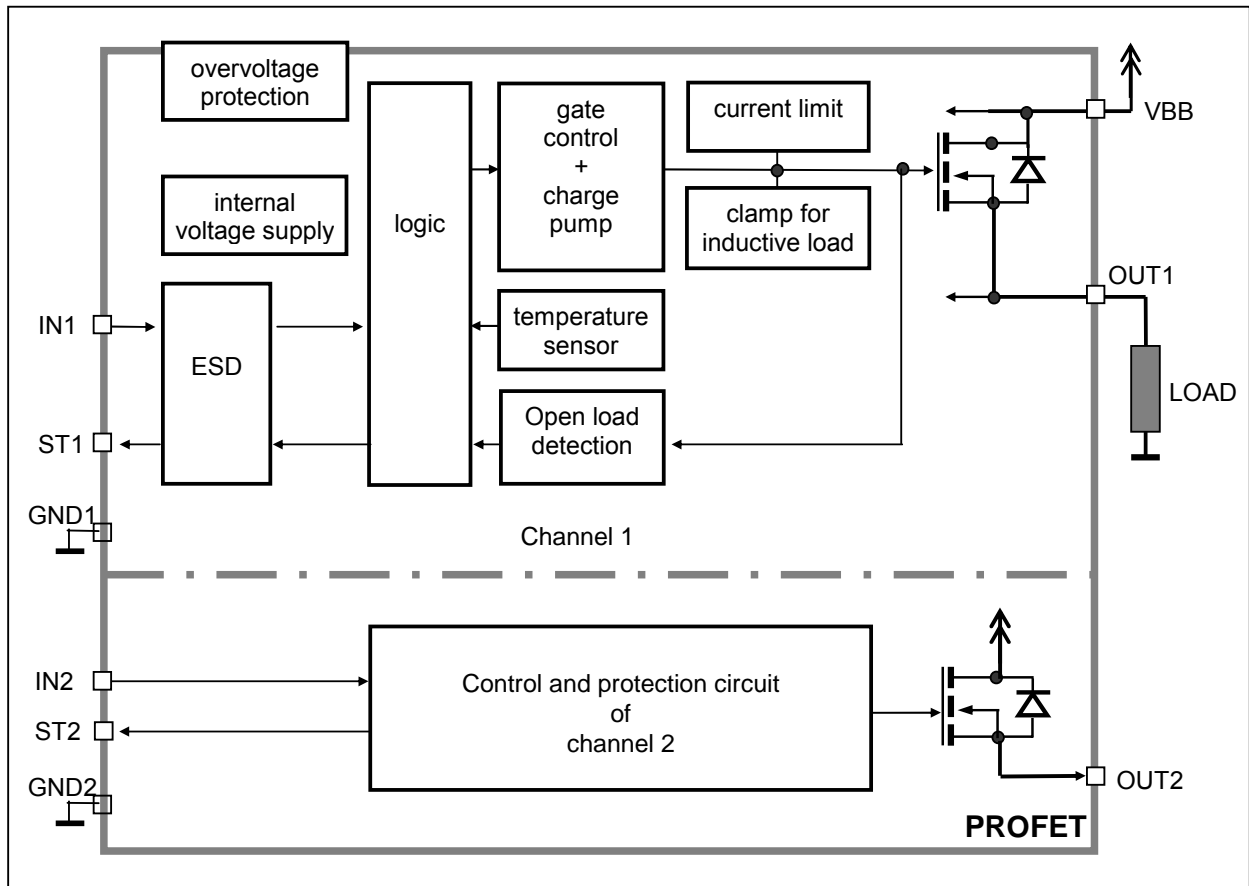

Pin Definitions and Functions

Pin	Symbol	Function
1,10, 11,12, 15,16, 19,20	V_{bb}	Positive power supply voltage. Design the wiring for the simultaneous max. short circuit currents from channel 1 to 2 and also for low thermal resistance
3	IN1	Input 1,2, activates channel 1,2 in case of logic high signal
7	IN2	
17,18	OUT1	Output 1,2, protected high-side power output of channel 1,2. Design the wiring for the max. short circuit current
13,14	OUT2	
4	ST1	Diagnostic feedback 1,2 of channel 1,2, open drain, low on failure
8	ST2	
2	GND1	Ground 1 of chip 1 (channel 1)
6	GND2	Ground 2 of chip 2 (channel 2)
5,9	N.C.	Not Connected

Pin configuration

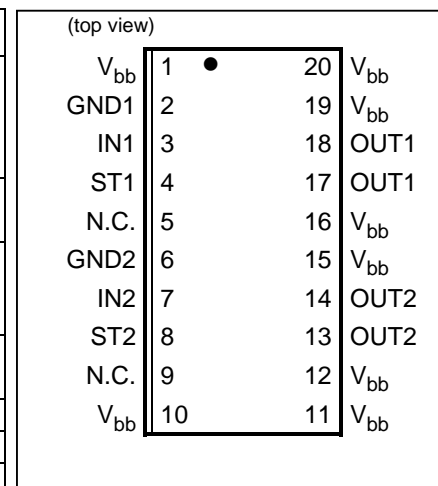

Maximum Ratings at $T_j = 25^\circ\text{C}$ unless otherwise specified

Parameter	Symbol	Values	Unit	
Supply voltage (overvoltage protection see page 4)	V_{bb}	43	V	
Supply voltage for full short circuit protection $T_{j,start} = -40 \dots +150^\circ\text{C}$	V_{bb}	24	V	
Load current (Short-circuit current, see page 5)	I_L	self-limited	A	
Load dump protection ¹⁾ $V_{LoadDump} = V_A + V_S$, $V_A = 13.5\text{ V}$ $R_l^{2)}$ = 2 Ω , $t_d = 200\text{ ms}$; IN = low or high, each channel loaded with $R_L = 9.0\ \Omega$,	$V_{Load\ dump}^{3)}$	60	V	
Operating temperature range	T_j	-40 ... +150	$^\circ\text{C}$	
Storage temperature range	T_{stg}	-55 ... +150		
Power dissipation (DC) ⁴⁾ (all channels active)	$T_a = 25^\circ\text{C}$: $T_a = 85^\circ\text{C}$:	P_{tot}	3.8 2.0	W
Maximal switchable inductance, single pulse $V_{bb} = 12\text{V}$, $T_{j,start} = 150^\circ\text{C}^{4)}$, $I_L = 4.0\text{ A}$, $E_{AS} = 296\text{ mJ}$, 0 Ω one channel: $I_L = 6.0\text{ A}$, $E_{AS} = 631\text{ mJ}$, 0 Ω two parallel channels: see diagrams on page 9	Z_L	19.0 17.5	mH	
Electrostatic discharge capability (ESD) (Human Body Model) acc. MIL-STD883D, method 3015.7 and ESD assn. std. S5.1-1993 $R = 1.5\text{ k}\Omega$; $C = 100\text{ pF}$	IN: ST: out to all other pins shorted:	V_{ESD}	1.0 4.0 8.0	kV
Input voltage (DC)	V_{IN}	-10 ... +16	V	
Current through input pin (DC)	I_{IN}	± 2.0	mA	
Current through status pin (DC) see internal circuit diagram page 8	I_{ST}	± 5.0		

Thermal Characteristics

Parameter and Conditions	Symbol	Values			Unit
		min	typ	Max	
Thermal resistance junction - soldering point ^{4),5)} each channel:	R_{thjs}	--	--	12	K/W
junction - ambient ⁴⁾ one channel active:	R_{thja}	--	40	--	
all channels active:		--	33	--	

1) Supply voltages higher than $V_{bb(AZ)}$ require an external current limit for the GND and status pins (a 150 Ω resistor for the GND connection is recommended).



2) R_l = internal resistance of the load dump test pulse generator

3) $V_{Load\ dump}$ is setup without the DUT connected to the generator per ISO 7637-1 and DIN 40839

4) Device on 50mm*50mm*1.5mm epoxy PCB FR4 with 6cm² (one layer, 70 μm thick) copper area for V_{bb} connection. PCB is vertical without blown air. See page 14

5) Soldering point: upper side of solder edge of device pin 15. See page 14

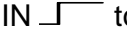
Electrical Characteristics

Parameter and Conditions, each of the two channels at $T_j = -40\dots+150^\circ\text{C}$, $V_{bb} = 12\text{ V}$ unless otherwise specified	Symbol	Values			Unit
		min	typ	Max	
Load Switching Capabilities and Characteristics					
On-state resistance (V_{bb} to OUT); $I_L = 2\text{ A}$, $V_{bb} \geq 7\text{ V}$ each channel, $T_j = 25^\circ\text{C}$: $T_j = 150^\circ\text{C}$: two parallel channels, $T_j = 25^\circ\text{C}$: see diagram, page 10	R_{ON}	--	36 67 18	40 75 20	m Ω
Nominal load current one channel active: two parallel channels active: Device on PCB ⁶⁾ , $T_a = 85^\circ\text{C}$, $T_j \leq 150^\circ\text{C}$	$I_{L(NOM)}$	4.4 6.7	4.8 7.3	--	A
Output current while GND disconnected or pulled up ⁷⁾ ; $V_{bb} = 30\text{ V}$, $V_{IN} = 0$, see diagram page 8	$I_{L(GNDhigh)}$	--	--	2	mA
Turn-on time ⁸⁾ IN  to 90% V_{OUT} :	t_{on}	50	100	200	μs
Turn-off time IN  to 10% V_{OUT} : $R_L = 12\ \Omega$	t_{off}	50	120	250	μs
Slew rate on ⁸⁾ $T_j = -40^\circ\text{C}$: 10 to 30% V_{OUT} , $R_L = 12\ \Omega$ $T_j = 25^\circ\text{C}\dots 150^\circ\text{C}$:	dV/dt_{on}	0.15 0.15	-- --	1 0.8	V/ μs
Slew rate off ⁸⁾ $T_j = -40^\circ\text{C}$: 70 to 40% V_{OUT} , $R_L = 12\ \Omega$ $T_j = 25^\circ\text{C}\dots 150^\circ\text{C}$:	$-dV/dt_{off}$	0.15 0.15	-- --	1 0.8	V/ μs

Operating Parameters

Operating voltage $T_j = -40$ $T_j = 25\dots 150^\circ\text{C}$:	$V_{bb(on)}$	4.75	-- --	41 43	V
Overvoltage protection ⁹⁾ $T_j = -40^\circ\text{C}$: $I_{bb} = 40\text{ mA}$ $T_j = 25\dots 150^\circ\text{C}$:	$V_{bb(AZ)}$	41 43	-- 47	-- 52	V
Standby current ¹⁰⁾ $T_j = -40^\circ\text{C}\dots 25^\circ\text{C}$: $V_{IN} = 0$; see diagram page 10 $T_j = 150^\circ\text{C}$:	$I_{bb(off)}$	-- --	10 --	16 50	μA
Leakage output current (included in $I_{bb(off)}$) $V_{IN} = 0$	$I_{L(off)}$	--	1	10	μA
Operating current ¹¹⁾ , $V_{IN} = 5\text{ V}$, $I_{GND} = I_{GND1} + I_{GND2}$, one channel on: two channels on:	I_{GND}	-- --	0.8 1.6	1.4 2.8	mA

6) Device on 50mm*50mm*1.5mm epoxy PCB FR4 with 6cm² (one layer, 70 μm thick) copper area for V_{bb} connection. PCB is vertical without blown air. See page 14

7) not subject to production test, specified by design

8) See timing diagram on page 11.

9) Supply voltages higher than $V_{bb(AZ)}$ require an external current limit for the GND and status pins (a 150 Ω resistor for the GND connection is recommended). See also $V_{ON(CL)}$ in table of protection functions and circuit diagram on page 8.

10) Measured with load; for the whole device; all channels off

11) Add I_{ST} , if $I_{ST} > 0$

Parameter and Conditions, each of the two channels at $T_j = -40\dots+150^\circ\text{C}$, $V_{bb} = 12\text{ V}$ unless otherwise specified	Symbol	Values			Unit
		min	typ	Max	

Protection Functions¹²⁾

Current limit, (see timing diagrams, page 12)					
$T_j = -40^\circ\text{C}$:	$I_{L(\text{lim})}$	40	49	60	A
$T_j = 25^\circ\text{C}$:		33	41	48	
$T_j = +150^\circ\text{C}$:		23	29	35	
Repetitive short circuit current limit, $T_j = T_{jt}$ each channel two parallel channels (see timing diagrams, page 12)	$I_{L(\text{SCR})}$	--	30	--	A
		--	30	--	
Initial short circuit shutdown time $T_{j,\text{start}} = 25^\circ\text{C}$: (see timing diagrams on page 12)	$t_{\text{off}(\text{SC})}$	--	1.7	--	ms
Output clamp (inductive load switch off) ¹³⁾ at $V_{\text{ON}(\text{CL})} = V_{bb} - V_{\text{OUT}}$, $I_L = 40\text{ mA}$	$V_{\text{ON}(\text{CL})}$				V
$T_j = -40^\circ\text{C}$:		41	--	--	
$T_j = 25^\circ\text{C}\dots 150^\circ\text{C}$:		43	47	52	
Thermal overload trip temperature	T_{jt}	150	--	--	$^\circ\text{C}$
Thermal hysteresis	ΔT_{jt}	--	10	--	K

Reverse Battery

Reverse battery voltage ¹⁴⁾	$-V_{bb}$	--	--	32	V
Drain-source diode voltage ($V_{\text{out}} > V_{bb}$) $I_L = -4.0\text{ A}$, $T_j = +150^\circ\text{C}$	$-V_{\text{ON}}$	--	600	--	mV

¹²⁾ Integrated protection functions are designed to prevent IC destruction under fault conditions described in the data sheet. Fault conditions are considered as "outside" normal operating range. Protection functions are not designed for continuous repetitive operation.

¹³⁾ If channels are connected in parallel, output clamp is usually accomplished by the channel with the lowest $V_{\text{ON}(\text{CL})}$



¹⁴⁾ Requires a $150\ \Omega$ resistor in GND connection. The reverse load current through the intrinsic drain-source diode has to be limited by the connected load. Power dissipation is higher compared to normal operating conditions due to the voltage drop across the drain-source diode. The temperature protection is not active during reverse current operation! Input and Status currents have to be limited (see max. ratings page 3 and circuit page 8).

Parameter and Conditions, each of the two channels at $T_j = -40\dots+150^\circ\text{C}$, $V_{bb} = 12\text{ V}$ unless otherwise specified	Symbol	Values			Unit
		min	typ	Max	

Diagnostic Characteristics

Open load detection current, (on-condition) each channel	$I_{L(OL)}$	100	--	900	mA
---	-------------	-----	----	-----	----

Input and Status Feedback¹⁵⁾

Input resistance (see circuit page 8)	R_i	2.5	3.5	6	k Ω
Input turn-on threshold voltage 	$V_{IN(T+)}$	1.7	--	3.2	V
Input turn-off threshold voltage 	$V_{IN(T-)}$	1.5	--	--	V
Input threshold hysteresis	$\Delta V_{IN(T)}$	--	0.5	--	V
Off state input current $V_{IN} = 0.4\text{ V}$:	$I_{IN(off)}$	1	--	50	μA
On state input current $V_{IN} = 5\text{ V}$:	$I_{IN(on)}$	20	50	90	μA
Delay time for status with open load after switch off; (see diagram on page 13)	$t_{d(ST\ OL4)}$	100	520	900	μs
Status invalid after positive input slope (open load)	$t_{d(ST)}$	--	--	500	μs
Status output (open drain)					
Zener limit voltage $I_{ST} = +1.6\text{ mA}$:	$V_{ST(high)}$	5.4	6.1	--	V
ST low voltage $I_{ST} = +1.6\text{ mA}$:	$V_{ST(low)}$	--	--	0.4	

¹⁵⁾ If ground resistors R_{GND} are used, add the voltage drop across these resistors.

Truth Table

Channel 1	Input 1	Output 1	Status 1
Channel 2	Input 2	Output 2	Status 2
	level	level	BTS 736L2
Normal operation	L	L	H
	H	H	H
Open load	L	Z	H
	H	H	L
Overtemperature	L	L	H
	H	L	L

L = "Low" Level X = don't care Z = high impedance, potential depends on external circuit
H = "High" Level Status signal valid after the time delay shown in the timing diagrams

Parallel switching of channel 1 and 2 is easily possible by connecting the inputs and outputs in parallel. The status outputs ST1 and ST2 have to be configured as a 'Wired OR' function with a single pull-up resistor.

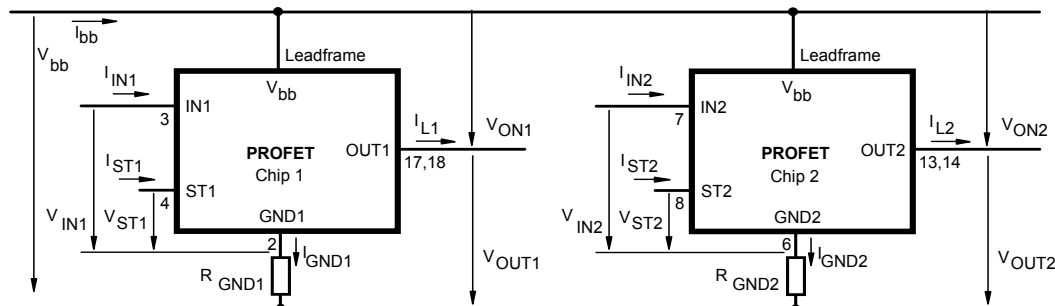
Terms

Leadframe (V_{bb}) is connected to pin 1,10,11,12,15,16,19,20

External R_{GND} optional; two resistors R_{GND1} , $R_{GND2} = 150 \Omega$ or a single resistor $R_{GND} = 75 \Omega$ for reverse battery protection up to the max. operating voltage.

Input circuit (ESD protection), IN1 or IN2

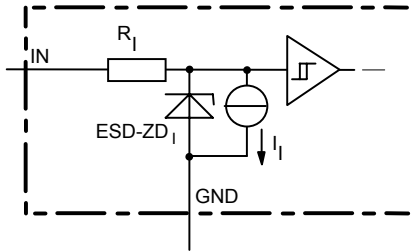

The use of ESD zener diodes as voltage clamp at DC conditions is not recommended.

Status output, ST1 or ST2

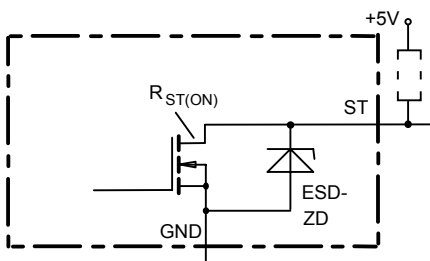

ESD-Zener diode: 6.1 V typ., max 5.0 mA; $R_{ST(ON)} < 375 \Omega$ at 1.6 mA. The use of ESD zener diodes as voltage clamp at DC conditions is not recommended.

Inductive and overvoltage output clamp, OUT1 or OUT2

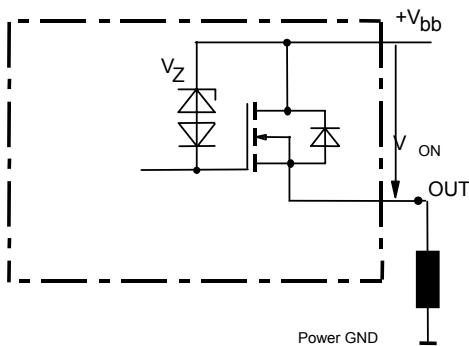

V_{ON} clamped to $V_{ON(CL)} = 47 \text{ V typ.}$

Overvolt. and reverse batt. protection

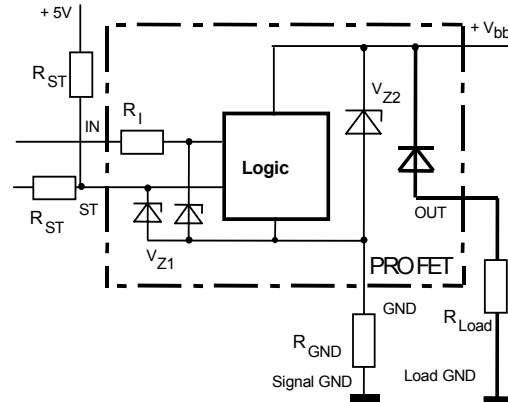

$V_{Z1} = 6.1 \text{ V typ.}$, $V_{Z2} = 47 \text{ V typ.}$, $R_{GND} = 150 \Omega$, $R_{ST} = 15 \text{ k}\Omega$, $R_I = 3.5 \text{ k}\Omega \text{ typ.}$

In case of reverse battery the load current has to be limited by the load. Temperature protection is not active

Open-load detection OUT1 or OUT2

ON-state diagnostic
Open load, if $V_{ON} < R_{ON} \cdot I_{L(OL)}$; IN high

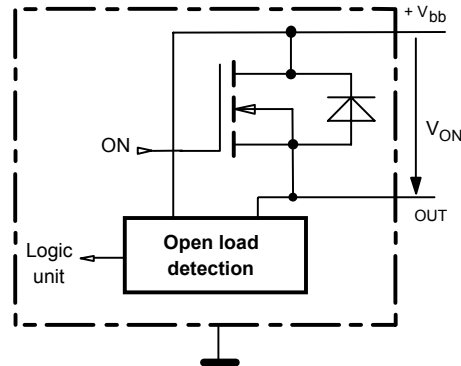

GND disconnect

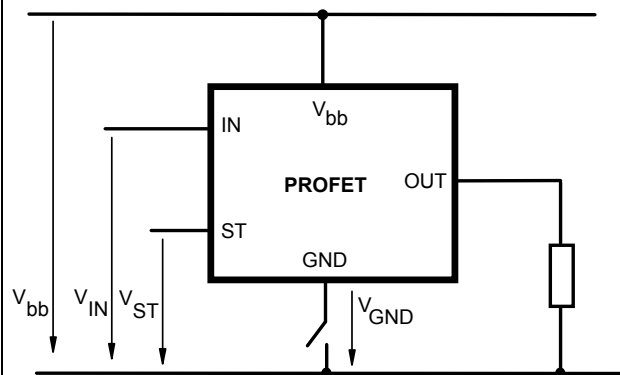

Any kind of load. In case of IN=high is $V_{OUT} \approx V_{IN} - V_{IN(T+)}$.
Due to $V_{GND} > 0$, no $V_{ST} = \text{low signal}$ available.

GND disconnect with GND pull up

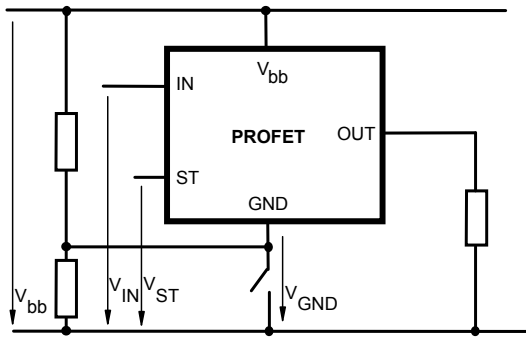

Any kind of load. If $V_{GND} > V_{IN} - V_{IN(T+)}$ device stays off
 Due to $V_{GND} > 0$, no V_{ST} = low signal available.

V_{bb} disconnect with energized inductive load

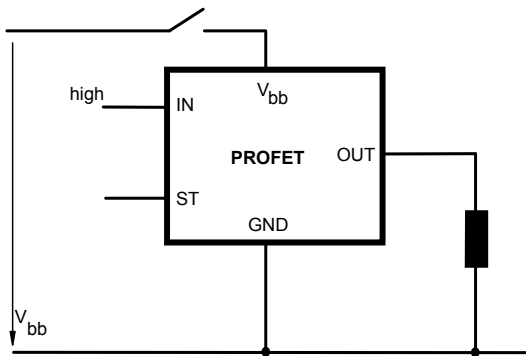

For inductive load currents up to the limits defined by Z_L (max. ratings and diagram on page 9) each switch is protected against loss of V_{bb} .

Consider at your PCB layout that in the case of V_{bb} disconnection with energized inductive load all the load current flows through the GND connection.

Inductive load switch-off energy dissipation

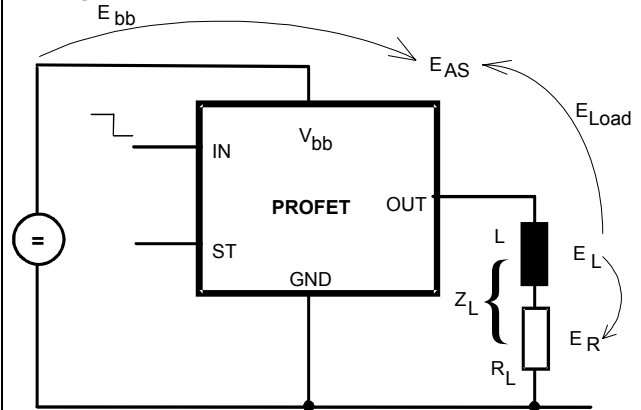

Energy stored in load inductance:

$$E_L = 1/2 \cdot L \cdot I_L^2$$

While demagnetizing load inductance, the energy dissipated in PROFET is

$$E_{AS} = E_{bb} + E_L - E_R = V_{ON(CL)} \cdot i_L(t) dt,$$

with an approximate solution for $R_L > 0 \Omega$:

$$E_{AS} = \frac{I_L \cdot L}{2 \cdot R_L} (V_{bb} + |V_{OUT(CL)}|) \ln \left(1 + \frac{I_L \cdot R_L}{|V_{OUT(CL)}|} \right)$$

Maximum allowable load inductance for a single switch off (one channel)⁴⁾

$$L = f(I_L); T_{j,start} = 150^\circ C, V_{bb} = 12 V, R_L = 0 \Omega$$

Z_L [mH]

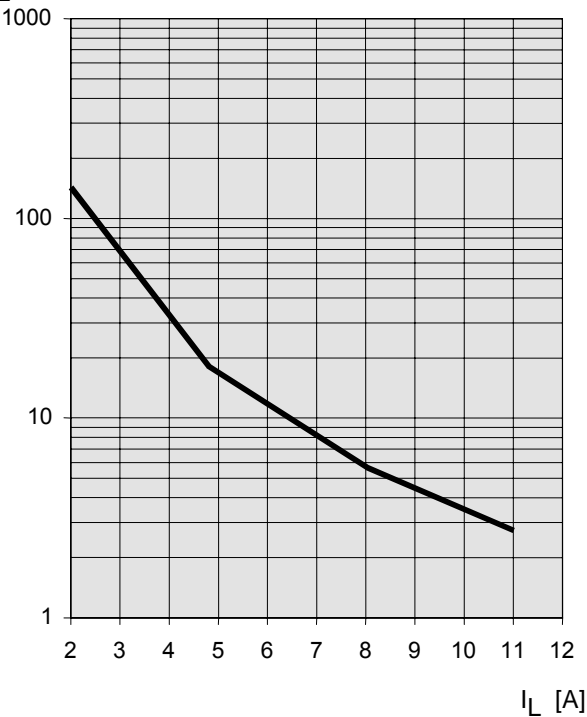

Typ. on-state resistance

$R_{ON} = f(V_{bb}, T_j)$; $I_L = 2\text{ A}$, $I_N = \text{high}$

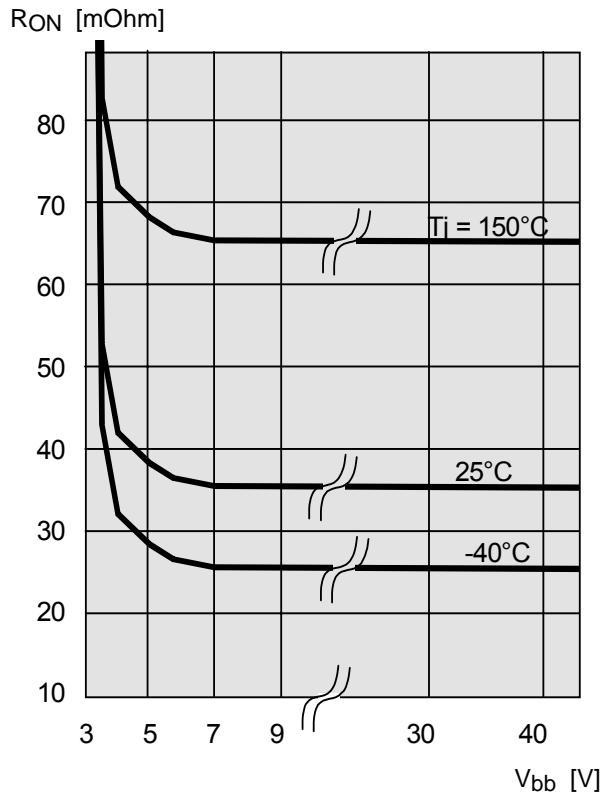

Typ. standby current

$I_{bb(off)} = f(T_j)$; $V_{bb} = 9\text{...}34\text{ V}$, $I_{N1,2} = \text{low}$

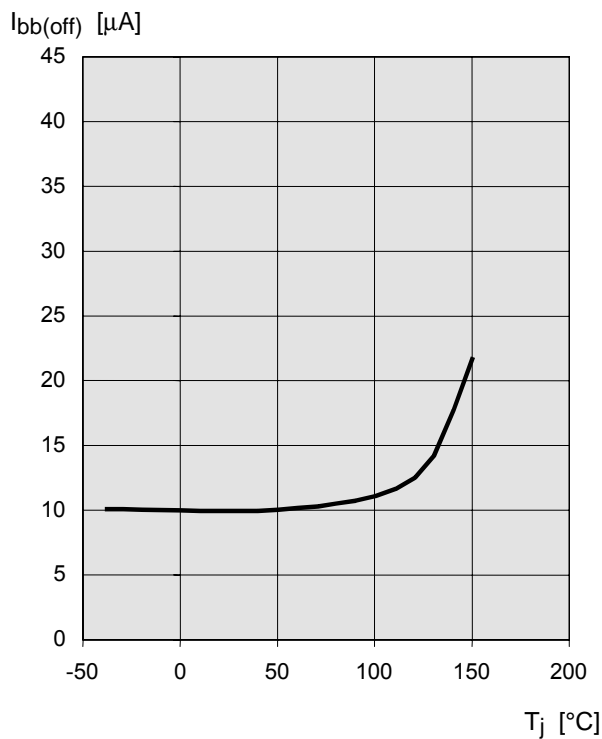

Timing diagrams

Both channels are symmetric and consequently the diagrams are valid for channel 1 and channel 2

Figure 1a: V_{bb} turn on:

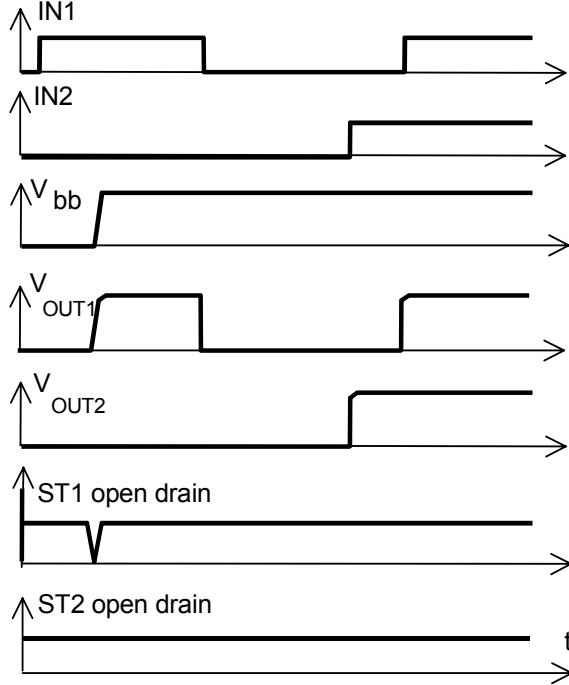
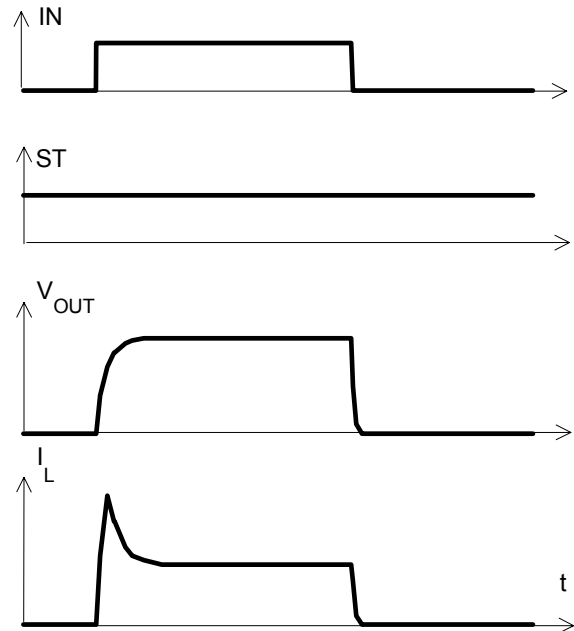

Figure 2b: Switching a lamp:



The initial peak current should be limited by the lamp and not by the current limit of the device.

Figure 2a: Switching a resistive load, turn-on/off time and slew rate definition:

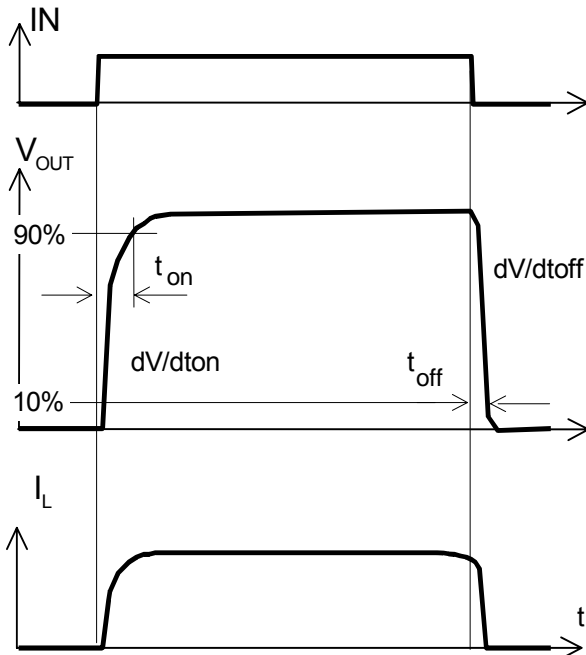
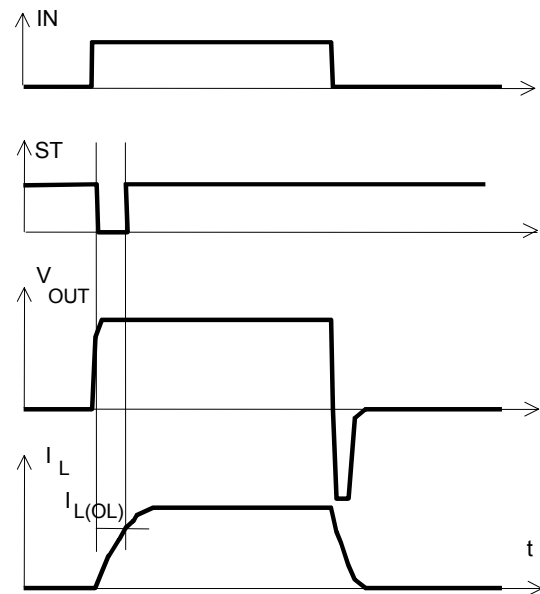
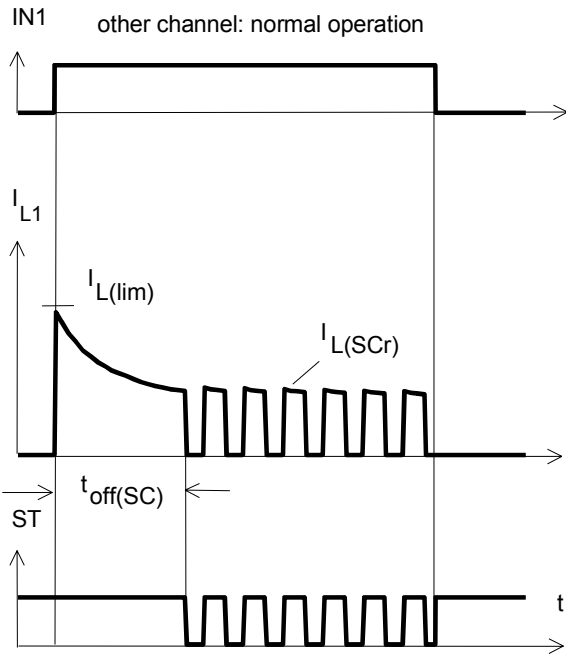

Figure 2c: Switching an inductive load



*) if the time constant of load is too large, open-load-status may occur

Figure 3a: Turn on into short circuit:
shut down by overtemperature, restart by cooling



Heating up of the chip may require several milliseconds, depending on external conditions

Figure 3b: Turn on into short circuit:
shut down by overtemperature, restart by cooling
(two parallel switched channels 1 and 2)

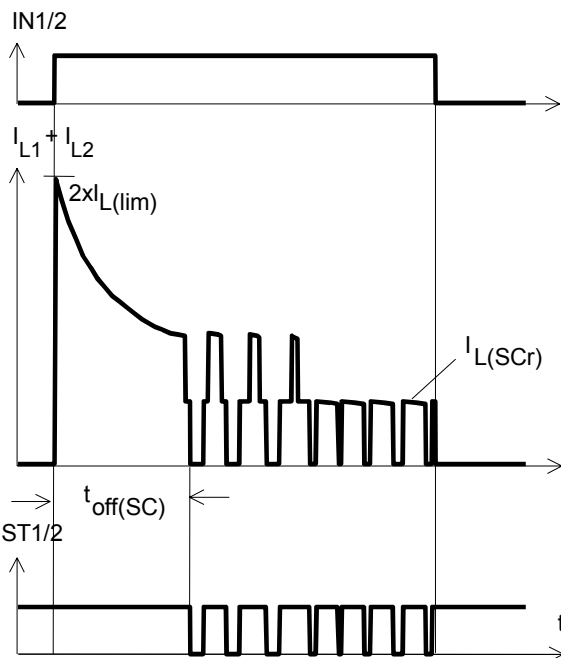

ST1 and ST2 have to be configured as a 'Wired OR' function ST1/2 with a single pull-up resistor.

Figure 4a: Overtemperature:
Reset if $T_j < T_{jt}$

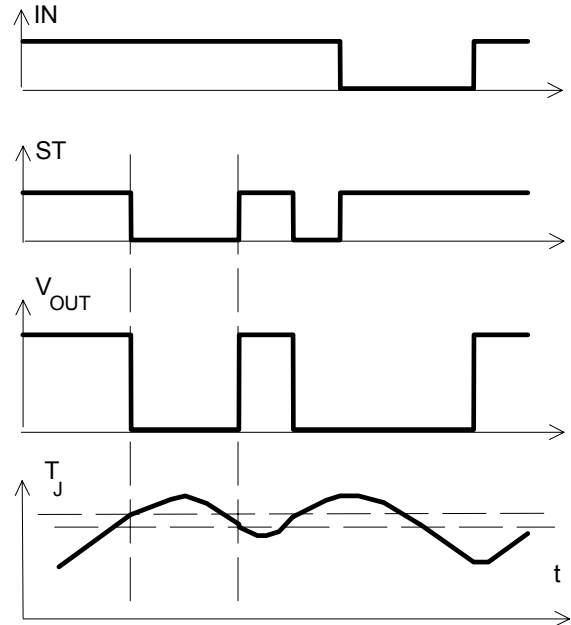
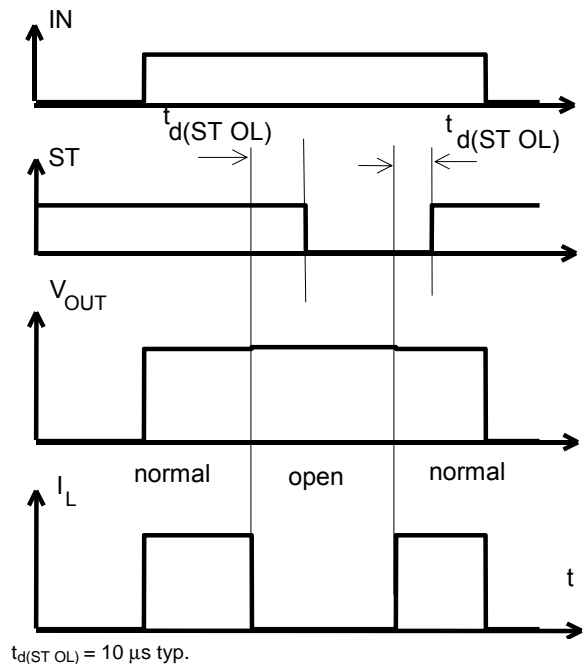
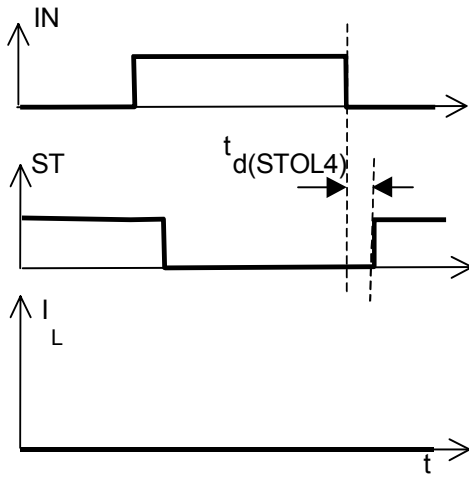

Figure 5a: Open load: detection in ON-state, open load occurs in on-state



$t_{d(ST OL)} = 10 \mu s$ typ.

Figure 5b: Open load: turn on/off to open load



Package and Ordering Code

Standard: P-DSO-20-9

Sales Code	BTS 736 L2
Ordering Code	Q67060-S7011-A2

All dimensions in millimetres

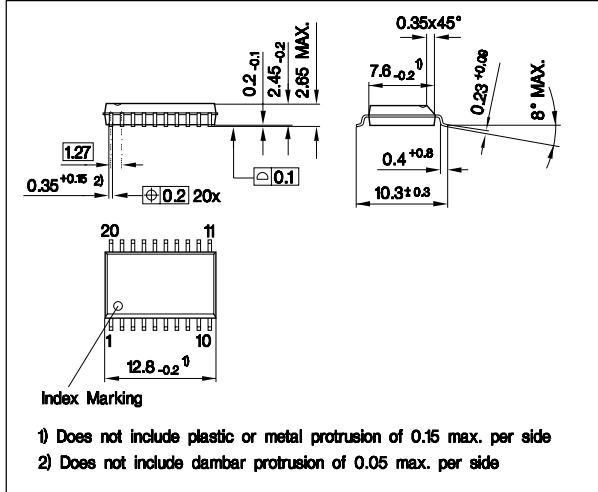

Definition of soldering point with temperature T_S :
 upper side of solder edge of device pin 15.

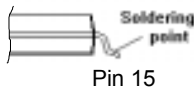

Printed circuit board (FR4, 1.5mm thick, one layer
 70 μ m, 6cm² active heatsink area) as a reference for
 max. power dissipation P_{tot} , nominal load current
 $I_{L(NOM)}$ and thermal resistance R_{thja}

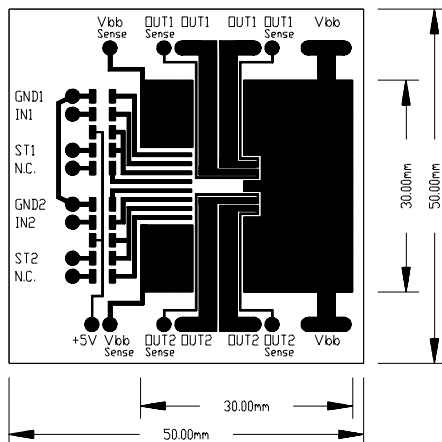

Published by
Infineon Technologies AG,
St.-Martin-Strasse 53,
D-81669 München
 © Infineon Technologies AG 2001
All Rights Reserved.

Attention please!
 The information herein is given to describe certain components and shall not be considered as a guarantee of characteristics.

Terms of delivery and rights to technical change reserved.

We hereby disclaim any and all warranties, including but not limited to warranties of non-infringement, regarding circuits, descriptions and charts stated herein.

Infineon Technologies is an approved CECC manufacturer.

Information
 For further information on technology, delivery terms and conditions and prices please contact your nearest Infineon Technologies Office in Germany or our Infineon Technologies Representatives worldwide (see address list).

Warnings
 Due to technical requirements components may contain dangerous substances. For information on the types in question please contact your nearest Infineon Technologies Office.

Infineon Technologies Components may only be used in life-support devices or systems with the express written approval of Infineon Technologies, if a failure of such components can reasonably be expected to cause the failure of that life-support device or system, or to affect the safety or effectiveness of that device or system. Life support devices or systems are intended to be implanted in the human body, or to support and/or maintain and sustain and/or protect human life. If they fail, it is reasonable to assume that the health of the user or other persons may be endangered.