

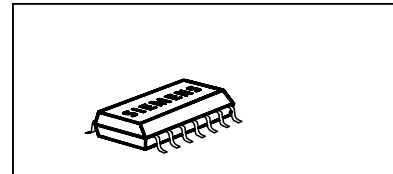
**Two Channels: 2 x 100mΩ**  
**Status Feedback**  
**Suitable for 42V**



**Product Summary**

Operating Voltage	$V_{bb(on)}$	7.0 ... 58V	
	Active channels	One	two parallel
On-state Resistance	$R_{ON}$	105mΩ	53mΩ
Nominal load current	$I_{L(NOM)}$	2.9A	4.2A
Current limitation	$I_{L(SCr)}$	8A	8A

**Package**



PG-DSO14

**General Description**

- N channel vertical power MOSFET with charge pump, ground referenced CMOS compatible input and diagnostic feedback, monolithically integrated in Smart SIPMOS® 80V technology.
- Providing embedded protective functions
- An array of resistors is integrated in order to reduce the external components

**Applications**

- $\mu$ C compatible high-side power switch with diagnostic feedback for 12V and 24V and **42V** grounded loads
- All types of resistive, inductive and capacitive loads
- Most suitable for inductive loads
- Replaces electromechanical relays, fuses and discrete circuits

**Basic Functions**

- CMOS compatible input
- Improved electromagnetic compatibility (EMC)
- Fast demagnetization of inductive loads
- Stable behaviour at undervoltage
- Wide operating voltage range
- Logic ground independent from load ground
- Optimized inrush current capability

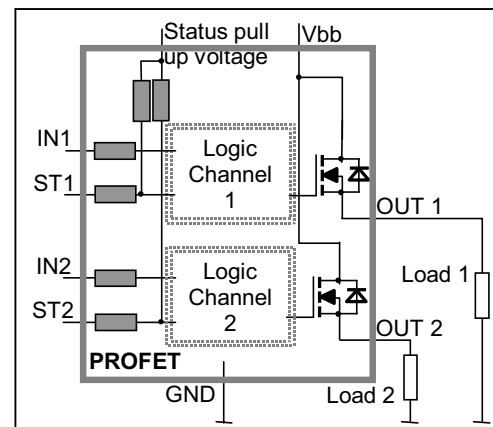
**Protection Functions**

- Short circuit protection
- Overload protection
- Current limitation
- Thermal shutdown
- Overvoltage protection (including load dump) with external resistor
- Reverse battery protection with external resistor
- Loss of ground and loss of  $V_{bb}$  protection
- Electrostatic discharge protection (ESD)

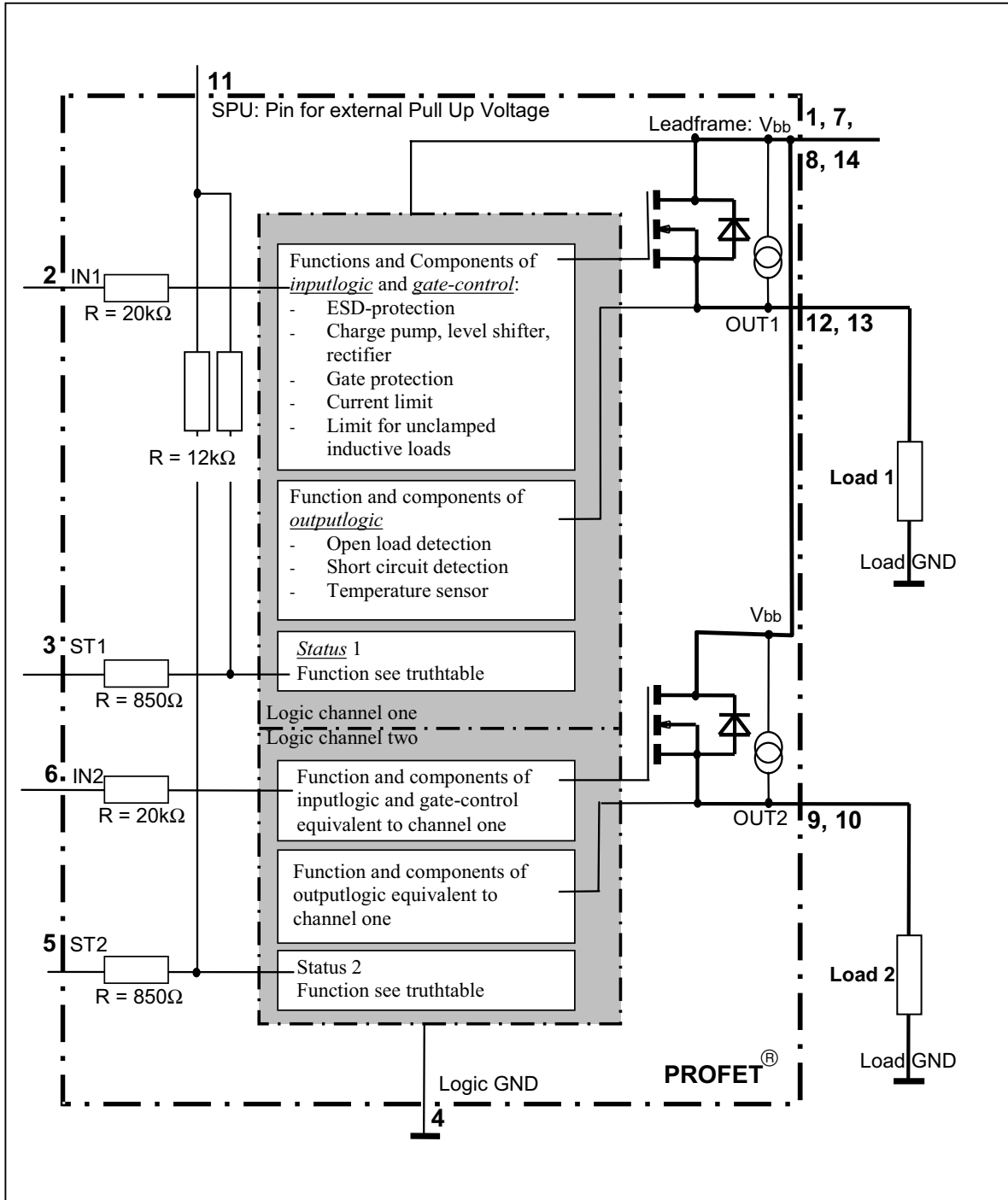
**Diagnostic Function**

- Diagnostic feedback with open drain output and integrated pull up resistors
- Open load detection in OFF-state
- Feedback of thermal shutdown in ON-state
- Diagnostic feedback of both channels works properly in case of inverse current

**Block Diagram**



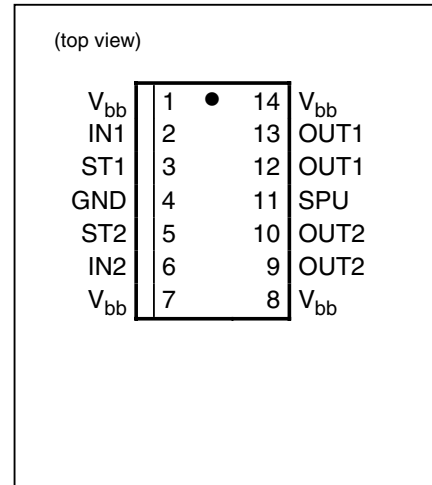
Functional diagram



### Pin Definitions and Functions

Pin	Symbol	Function
1,7, 8,14,	$V_{bb}$	<b>Positive power supply voltage.</b> Design the wiring for the simultaneous max. short circuit currents from channel 1 to 2 and also for low thermal resistance
2	IN1	<b>Input 1,2</b> activates channel 1,2 in case of logic high signal
6	IN2	
12,13	OUT1	<b>Output 1,2</b> protected high-side power output of channel 1,2. Design the wiring for the max. short circuit current; both outputpins have to be connected in parallel for operation according this spec.
9,10	OUT2	
3	ST1	<b>Diagnostic feedback 1,2</b> of channel 1,2 open drain
5	ST2	
4	GND	<b>Logic Ground</b>
11	SPU	Connection for <b>external pull up voltage</b> source for the open drain status output. Pull up resistors are integrated.

### Pin configuration



Parameter	Symbol	Values	Unit
Supply voltage (overvoltage protection see page 6)	$V_{bb}$	58	V
Supply voltage for full short circuit protection $T_{j,start} = -40 \dots +150^\circ\text{C}$	$V_{bb}$	50	V
Output Voltage to $V_{bb}$	$V_{ON}$	70	V
Negative voltage slope at output	$-dV_{OUT}/dt$	20	V/ $\mu\text{s}$
Load current (Short-circuit current, see page 7)	$I_L$	$I_{L(LIM)}^{1)}$	A
Load dump protection <sup>2)</sup> $V_{LoadDump} = V_A + V_S$ , $V_A = 27\text{ V}$ $R_1^{3)} = 8\ \Omega$ , $t_d = 200\text{ ms}$ ; IN= low or high, each channel loaded with $R_L = 20\ \Omega$ ,	$V_{Load\ dump}^{4)}$	70	V
Operating temperature range	$T_j$	-40 ...+150	$^\circ\text{C}$
Storage temperature range	$T_{stg}$	-55 ...+150	$^\circ\text{C}$
Power dissipation (DC) <sup>5)</sup> (all channels active)	$P_{tot}$	$T_a = 25^\circ\text{C}$ : 3.0 $T_a = 85^\circ\text{C}$ : 1.6	W
Maximal switchable inductance, single pulse $V_{bb} = 12\text{V}$ , $T_{j,start} = 150^\circ\text{C}^{5)}$ , $I_L = 2.5\text{ A}$ , $E_{AS} = 110\text{ mJ}$ , $0\ \Omega$ one channel: $I_L = 3.5\text{ A}$ , $E_{AS} = 278\text{ mJ}$ , $0\ \Omega$ two parallel channels: see diagrams on page 12	$Z_L$	23.0 30.0	mH
Electrostatic discharge capability (ESD): (Human Body Model) acc. MIL-STD883D, method 3015.7 and ESD assn. std. S5.1-1993 $R=1.5\text{k}\Omega$ ; $C=100\text{pF}$	$V_{ESD}$	1.0	kV
Input voltage (DC)	$V_{IN}$	$\pm 42$	V
Current through input pin (DC)	$I_{IN}$	$\pm 2.0$	mA
Current through status pin (DC)	$I_{ST}$	$\pm 2.0$	
Status pull up voltage	$V_{SPU}$	$\pm 42$	V

- 1) Current limit is a protection function. Operation in current limitation is considered as "outside" normal operating range. Protection functions are not designed for continuous repetitive operation.
- 2) Supply voltages higher than  $V_{bb(AZ)}$  require an external current limit for the GND and status pins (a 150 $\Omega$  resistor for the GND connection is recommended).
- 3)  $R_1$  = internal resistance of the load dump test pulse generator
- 4)  $V_{Load\ dump}$  is setup without the DUT connected to the generator per ISO 7637-1 and DIN 40839
- 5) Device on 50mm\*50mm\*1.5mm epoxy PCB FR4 with 6cm<sup>2</sup> (one layer, 70 $\mu\text{m}$  thick) copper area for  $V_{bb}$  connection. PCB is vertical without blown air. See page 15

Parameter and Conditions	Symbol	Values			Unit
		min	typ	Max	
Thermal resistance junction - soldering point <sup>5),6)</sup> each channel:	$R_{thjs}$	--	--	25	K/W
junction - ambient <sup>5)</sup> one channel active:	$R_{thja}$	--	45	--	
all channels active:		--	41	--	



### Electrical Characteristics

Parameter and Conditions, each of the two channels at $T_j = -40...+150^\circ\text{C}$ , $V_{bb} = 24\text{ V}$ unless otherwise specified	Symbol	Values			Unit
		min	typ	Max	

### Load Switching Capabilities and Characteristics

On-state resistance ( $V_{bb}$ to OUT); $I_L = 2\text{ A}$ , $V_{bb} \geq 7\text{ V}$	$R_{ON}$	--	90	105	m $\Omega$
each channel, $T_j = 25^\circ\text{C}$ :					
$T_j = 150^\circ\text{C}$ :					
two parallel channels, $T_j = 25^\circ\text{C}$ :	--	--	45	53	
see diagram, page 12					

<sup>6)</sup> Soldering point: Upper side of solder edge of device pin 15. See page 15

Parameter and Conditions, each of the two channels at $T_j = -40\dots+150^\circ\text{C}$ , $V_{bb} = 24\text{ V}$ unless otherwise specified	Symbol	Values			Unit
		min	typ	Max	
Nominal load current one channel active: two parallel channels active: Device on PCB <sup>7)</sup> , $T_a = 85^\circ\text{C}$ , $T_j \leq 150^\circ\text{C}$	$I_{L(\text{NOM})}$	2.5 4.0	2.9 4.2	-- --	A
Output current while GND disconnected or pulled up <sup>8)</sup> ; $V_{bb} = 30\text{ V}$ , $V_{IN} = 0$ , see diagram page 11	$I_{L(\text{GNDhigh})}$	--	--	1.0	mA
Turn-on time <sup>9)</sup> Turn-off time $R_L = 12\ \Omega$	IN  to 90% $V_{OUT}$ : IN  to 10% $V_{OUT}$ : $t_{on}$ $t_{off}$	-- --	-- --	55 95	$\mu\text{s}$
Slew rate on <sup>9)</sup> 10 to 30% $V_{OUT}$ , $R_L = 12\ \Omega$ :	$dV/dt_{on}$	1.0	--	5	$\text{V}/\mu\text{s}$
Slew rate off <sup>9)</sup> 70 to 40% $V_{OUT}$ , $R_L = 12\ \Omega$ :	$-dV/dt_{off}$	1.0	--	5	$\text{V}/\mu\text{s}$

### Operating Parameters

Operating voltage	$V_{bb(\text{on})}$	7.0	--	58	V
Undervoltage restart of charge pump $T_j = -40\dots+25^\circ\text{C}$ : $T_j = +150^\circ\text{C}$ :	$V_{bb(\text{ucp})}$	-- --	4 --	5.5 7.0	V
Overvoltage protection <sup>10)</sup> $I_{bb} = 40\text{ mA}$	$V_{bb(\text{AZ})}$	58.5	63	69	V
Standby current <sup>11)</sup> $V_{IN} = 0$ ; see diagram page 10	$I_{bb(\text{off})}$	-- -- --	13 -- 25	23 23 35	$\mu\text{A}$
Off-State output current (included in $I_{bb(\text{off})}$ ) $V_{IN} = 0$ ; each channel	$I_{L(\text{off})}$	--	3	--	$\mu\text{A}$
Operating current <sup>13)</sup> , $V_{IN} = 5\text{ V}$ ,	$I_{GND}$	-- --	1.0 2.0	1.5 3.0	mA
	one channel on: all channels on:				

7) Device on 50mm\*50mm\*1.5mm epoxy PCB FR4 with 6cm<sup>2</sup> (one layer, 70 $\mu\text{m}$  thick) copper area for  $V_{bb}$  connection. PCB is vertical without blown air. See page 15

8) not subject to production test, specified by design

9) See timing diagram on page 13.

10) Supply voltages higher than  $V_{bb(\text{AZ})}$  require an external current limit for the GND; a 150 $\Omega$  resistor is recommended. See also  $V_{ON(\text{CL})}$  in table of protection functions and circuit diagram on page 10.

11) Measured with load; for the whole device; all channels off

12) not subject to production test, specified by design

13) Add  $I_{ST}$ , if  $I_{ST} > 0$

Parameter and Conditions, each of the two channels at $T_j = -40\dots+150^\circ\text{C}$ , $V_{bb} = 24\text{ V}$ unless otherwise specified	Symbol	Values			Unit
		min	typ	Max	

**Protection Functions<sup>14)</sup>**

Current limit, (see timing diagrams, page 13)	$I_{L(\text{lim})}$	--	$T_j = -40^\circ\text{C}$ : 10	12	A
$T_j = 25^\circ\text{C}$ :			9	--	
$T_j = +150^\circ\text{C}$ :			5	8	
Repetitive short circuit current limit <sup>15)</sup> , $T_j = T_{jt}$ each channel two parallel channels (see timing diagrams, page 13)	$I_{L(\text{SCR})}$	--	8	--	A
			8	--	
Initial short circuit shutdown time $T_{j,\text{start}} = 25^\circ\text{C}$ : (see timing diagrams on page 13)	$t_{\text{off}(\text{SC})}$	--	2	--	ms
Output clamp (inductive load switch off) <sup>16)</sup> at $V_{\text{ON}(\text{CL})} = V_{bb} - V_{\text{OUT}}$ , $I_L = 1\text{ A}$	$V_{\text{ON}(\text{CL})}$	59	64	70	V
Thermal overload trip temperature	$T_{jt}$	150	--	--	$^\circ\text{C}$
Thermal hysteresis	$\Delta T_{jt}$	--	10	--	K

**Reverse Battery**

Reverse battery voltage <sup>17)</sup>	$-V_{bb}$	--	--	24	V
Drain-source diode voltage ( $V_{\text{out}} > V_{bb}$ ) <sup>18)</sup> $I_L = -3.0\text{ A}$ , $T_j = +150^\circ\text{C}$	$-V_{\text{ON}}$	--	650	--	mV

**Inverse current <sup>19)</sup>**

GND current in case of 3A inverse current <sup>20)</sup>	$I_{\text{GND}(\text{inv cur})}$	--	--	15	mA
--	----------------------------------	----	----	----	----

<sup>14)</sup> Integrated protection functions are designed to prevent IC destruction under fault conditions described in the data sheet. Fault conditions are considered as "outside" normal operating range. Protection functions are not designed for continuous repetitive operation.

<sup>15)</sup> not subject to production test, specified by design

<sup>16)</sup> If channels are connected in parallel, output clamp is usually accomplished by the channel with the lowest  $V_{\text{ON}(\text{CL})}$

<sup>17)</sup> Requires a 150  $\Omega$  resistor in GND connection. The reverse load current through the intrinsic drain-source diode has to be limited by the connected load. Power dissipation is higher compared to normal operating conditions due to the voltage drop across the drain-source diode. The temperature protection is not active during reverse current operation! Input and Status currents have to be limited (see max. ratings page 4 and circuit page 10).

<sup>18)</sup> not subject to production test, specified by design

<sup>19)</sup> not subject to production test, specified by design

<sup>20)</sup> In case of an inverse current of 3A the both status outputs must not be disturbed.



The neighbour channel can be switched normally; not all parameters lay within the range of the spec  
Please note, that in case of an inverse current no protection function is active. The power dissipation is higher compared to normal operation in forward mode due to the voltage drop across the drain-source diode

Parameter and Conditions, each of the two channels at $T_j = -40\dots+150^\circ\text{C}$ , $V_{bb} = 24\text{ V}$ unless otherwise specified	Symbol	Values			Unit
		min	typ	Max	

### Diagnostic Characteristics

Open load detection current <sup>21)</sup>	$I_{L(\text{off})}$	--	3	--	$\mu\text{A}$
Open load detection voltage	$V_{\text{OUT(OL)}}$	2.0	2.85	3.7	V
Short circuit detection voltage <sup>22)</sup> $V_{bb}$ (pin 1,7,8,14) to OUT1 (pin 12,13) resp. $V_{bb}$ (pin 1,7,8,14) to OUT2 (pin 9,10)	$V_{\text{ON(SC)}}$	--	4.0	--	V

### Input and Status Feedback <sup>23)</sup>

Integrated resistors; $T_j = 25^\circ\text{C}$ : (see circuit page 2)	Input	$R_I$	--	20	--	$\text{k}\Omega$
	Status	$R_{\text{ST}}$	0.53	0.85	1.2	$\text{k}\Omega$
	Status pull up	$R_{\text{pull up}}$	--	12	--	$\text{k}\Omega$
Input turn-on threshold voltage		$V_{\text{IN(T+)}}$	1.2	--	2.2	V
Input turn-off threshold voltage		$V_{\text{IN(T-)}}$	1.0	--	--	V
Input threshold hysteresis		$\Delta V_{\text{IN(T)}}$	--	0.25	--	V
Off state input current	$V_{\text{IN}} = 0.4\text{ V}$ :	$I_{\text{IN(off)}}$	1	--	15	$\mu\text{A}$
On state input current	$V_{\text{IN}} = 5\text{ V}$ :	$I_{\text{IN(on)}}$	10	25	50	$\mu\text{A}$
Status output (open drain)						
Zener limit voltage		$V_{\text{ST(high)}}$	5.4	6.1	--	V
Status low voltage	$V_{\text{SPU}} = 5\text{ V}$ :	$V_{\text{ST(low)}}$	--	--	0.4	

<sup>21)</sup> not subject to production test, specified by design

<sup>22)</sup> not subject to production test, specified by design

<sup>23)</sup> If a ground resistor  $R_{\text{GND}}$  is used, add the voltage drop across these resistors.

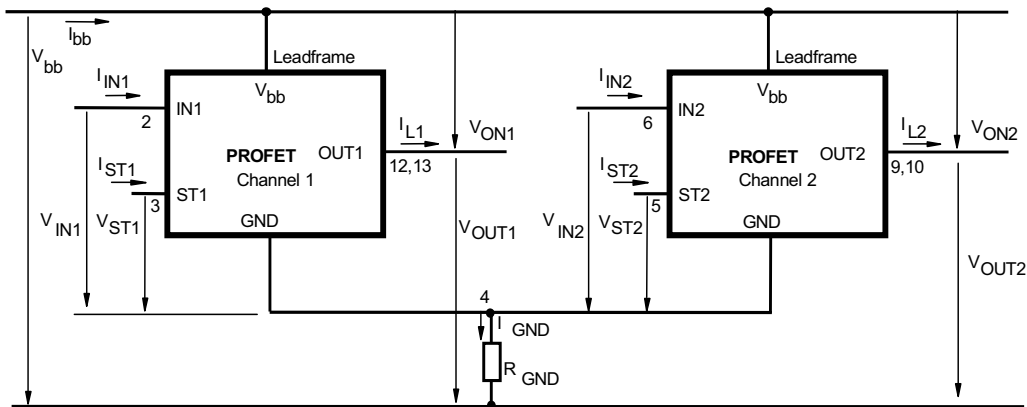


### Truth Table

Channel 1	Input 1	Output 1	Status 1
Channel 2	Input 2	Output 2	Status 2
	level	level	BTS 723
Normal operation	L	L	L
	H	H	H
Open load	L	$V_{OUT} > 2.7V$	H
	H	H	H
Short circuit to GND	L	L	L
	H	L	L
Short circuit to $V_{bb}$	L	H	H
	H	H	H
Overtemperature	L	L	L
	H	L	L

Parallel switching of channel 1 and 2 is easily possible by connecting the inputs and outputs in parallel. In this mode it is recommended to use only one status.

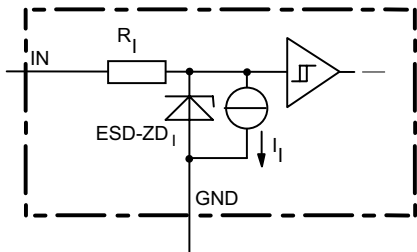
### Terms



Leadframe ( $V_{bb}$ ) is connected to pin **1,7,8,14**

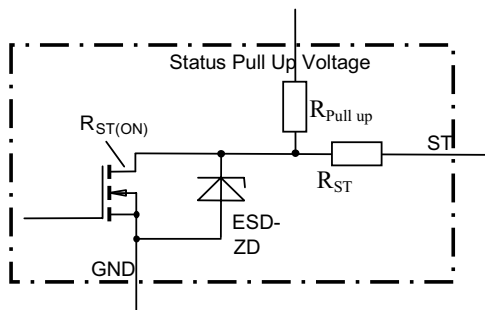
External  $R_{GND}$  optional; a single resistor  $R_{GND} = 150\Omega$  for reverse battery protection up to the max. operating voltage.

**Input circuit (ESD protection), IN1 or IN2**



The use of ESD zener diodes as voltage clamp at DC conditions is not recommended.

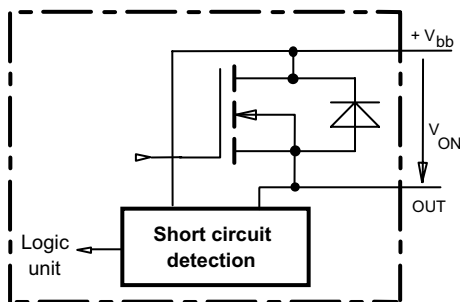
**Status output, ST1 or ST2**



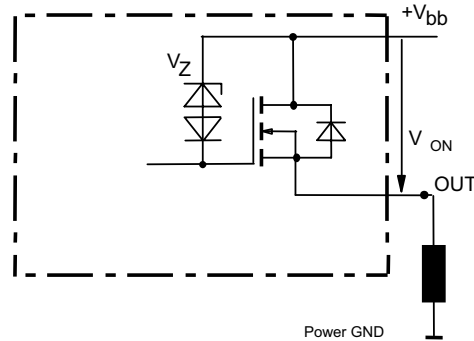
ESD-Zener diode: 6.1 V typ.,  $R_{ST(ON)} < 250 \Omega$ ,  
 $R_{ST} = 850 \Omega$  typ.,  $R_{pull\ up} = 12\ k\Omega$  typ.  
The use of ESD zener diodes as voltage clamp at DC conditions is not recommended

**Short Circuit detection**

Fault Signal at ST-Pin:  $V_{ON} > 4.0\ V$  typ, no switch off by the PROFET itself, external switch off recommended!

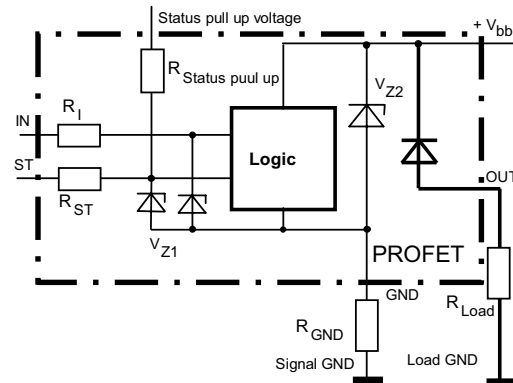


**Inductive and overvoltage output clamp, OUT1 or OUT2**



$V_{ON}$  clamped to  $V_{ON(CL)} = 64\ V$  typ.

**Overvolt. and reverse batt. protection**



$V_{Z1} = 6.1\ V$  typ.,  $V_{Z2} = 63\ V$  typ.,  $R_{GND} = 150 \Omega$ ,  
 $R_I = 850 \Omega$  typ.,  $R_{ST} = 20\ k\Omega$  typ.,  $R_{pull\ up} = 12\ k\Omega$  typ  
In case of reverse battery the load current has to be limited by the load. Temperature protection is not active

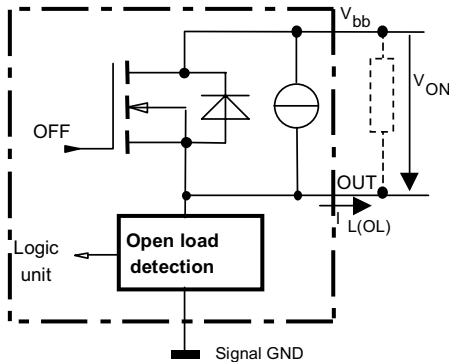
**Open-load detection, OUT1 or OUT2**

OFF-state diagnostic condition:

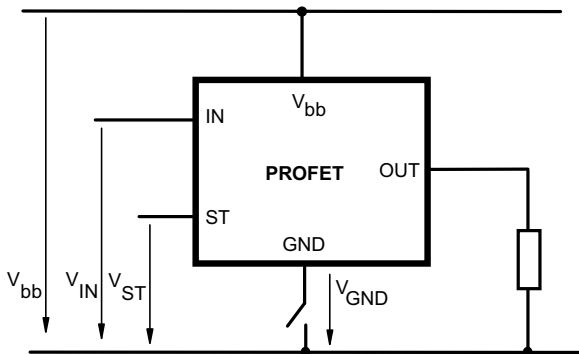
Open load, if  $V_{OUT} > 2.7\text{ V typ.}$  (IN low)

$I_{L(OL)}$  typ.  $2\mu\text{A}$

An external resistor can be used to increase the open load detection current



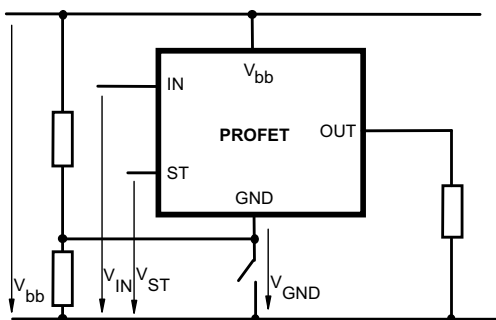
**GND disconnect**



Any kind of load.

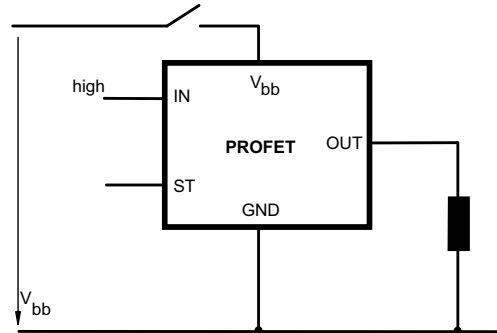
Due to  $V_{GND} > 0$ , no  $V_{ST} = \text{low}$  signal available.

**GND disconnect with GND pull up**



Any kind of load. If  $V_{GND} > V_{IN} - V_{IN(T+)}$  device stays off  
Due to  $V_{GND} > 0$ , no  $V_{ST} = \text{low}$  signal available.

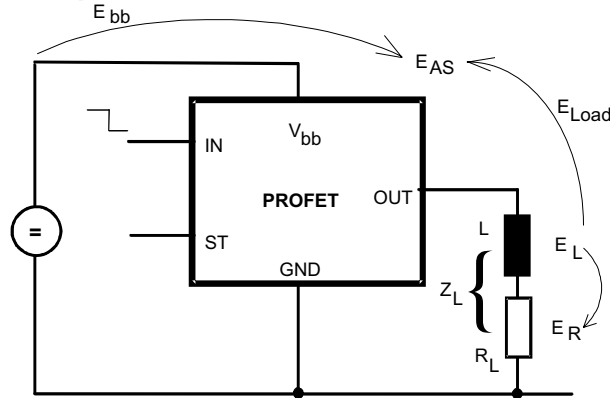
**V<sub>bb</sub> disconnect with energized inductive load**



For inductive load currents up to the limits defined by  $Z_L$  (max. ratings and diagram on page 12) each switch is protected against loss of  $V_{bb}$ .

Consider at your PCB layout that in the case of  $V_{bb}$  disconnection with energized inductive load all the load current flows through the GND connection.

**Inductive load switch-off energy dissipation**



Energy stored in load inductance:

$$E_L = \frac{1}{2} \cdot L \cdot I_L^2$$

While demagnetizing load inductance, the energy dissipated in PROFET is

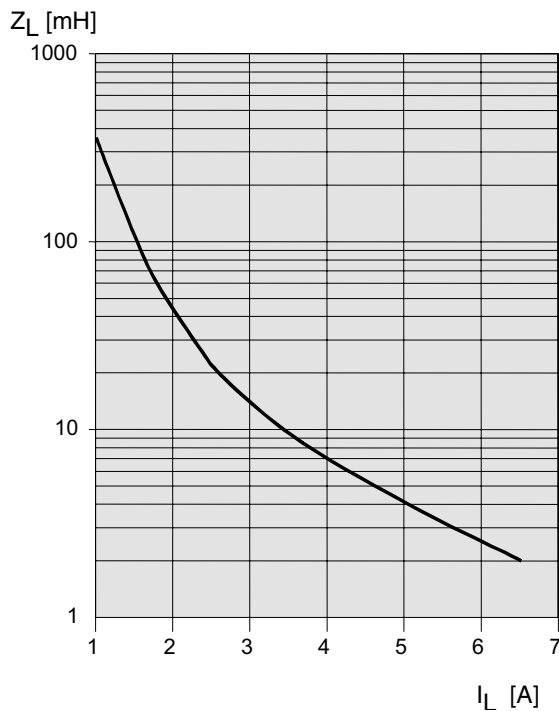
$$E_{AS} = E_{bb} + E_L - E_R = \int V_{ON(CL)} \cdot i_L(t) dt,$$

with an approximate solution for  $R_L > 0 \Omega$ :

$$E_{AS} = \frac{I_L \cdot L}{2 \cdot R_L} (V_{bb} + |V_{OUT(CL)}|) \ln \left( 1 + \frac{I_L \cdot R_L}{|V_{OUT(CL)}|} \right)$$

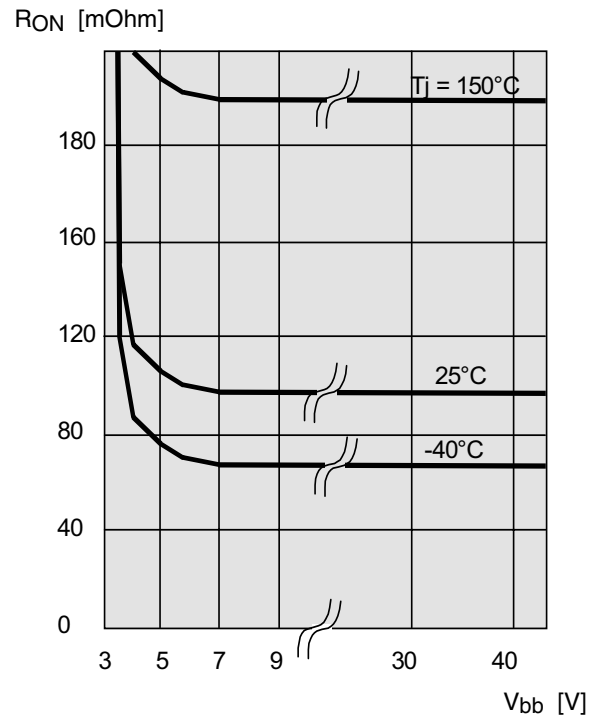
**Maximum allowable load inductance for a single switch off (one channel)<sup>5)</sup>**

$L = f(I_L)$ ;  $T_{j,start} = 150^\circ\text{C}$ ,  $V_{bb} = 12\text{V}$ ,  $R_L = 0 \Omega$



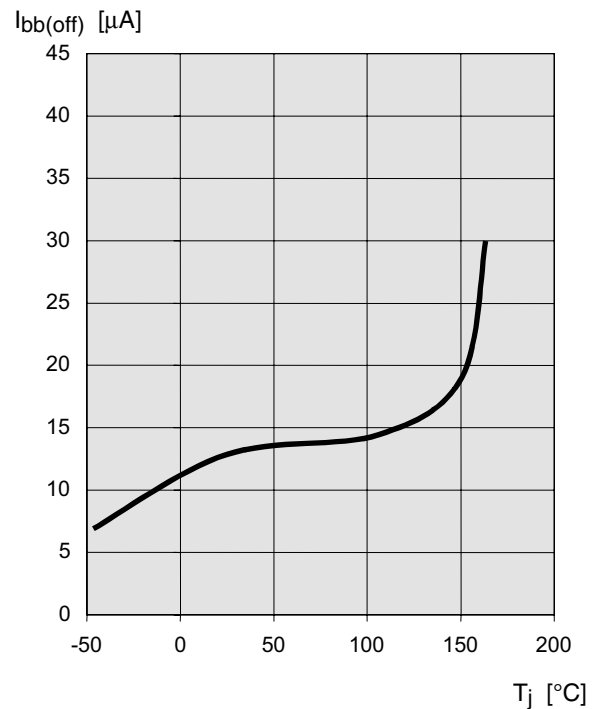
**Typ. on-state resistance**

$R_{ON} = f(V_{bb}, T_j)$ ;  $I_L = 2\text{A}$ ,  $I_N = \text{high}$



**Typ. standby current**

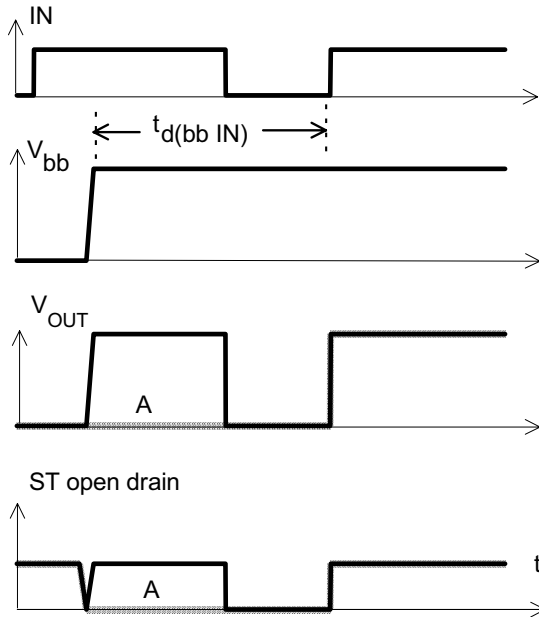
$I_{bb(off)} = f(T_j)$ ;  $V_{bb} = 9...34\text{V}$ ,  $I_{N1,2,3,4} = \text{low}$



## Timing diagrams

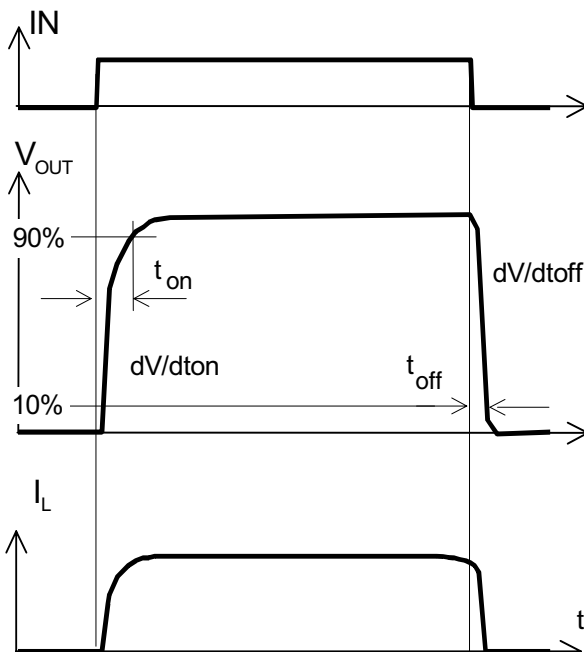
All channels are symmetric and consequently the diagrams are valid for channel 1 and channel 2

**Figure 1a:**  $V_{bb}$  turn on, :

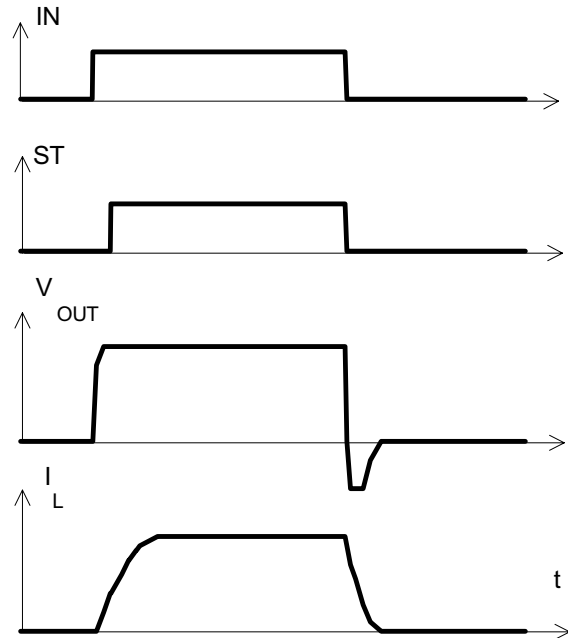


in case of too early  $V_{IN}$ =high the device may not turn on (curve A)  
 $t_{d(bb IN)}$  approx. 150  $\mu$ s

**Figure 2a:** Switching a resistive load, turn-on/off time and slew rate definition:

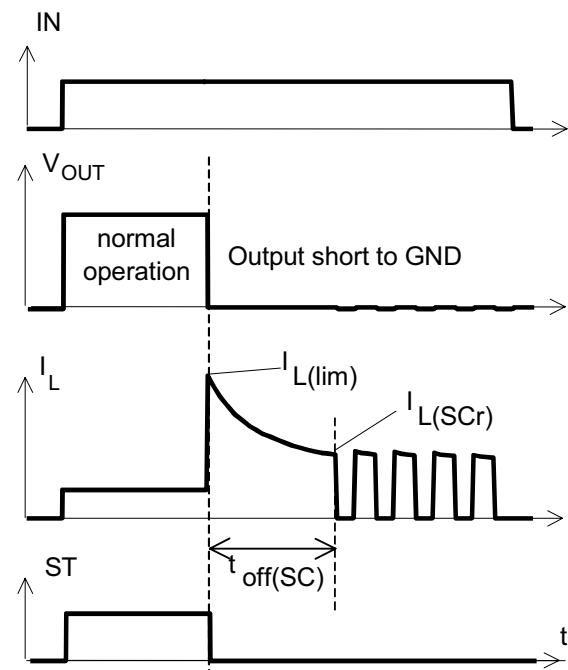


**Figure 2b:** Switching an inductive load

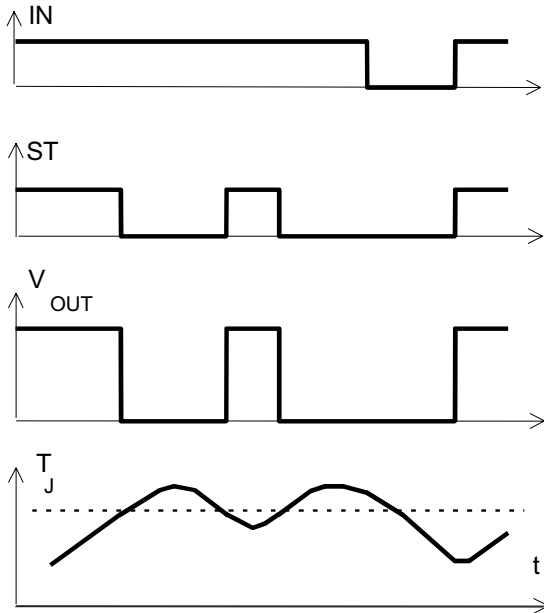


**Figure 3a:** Short circuit:

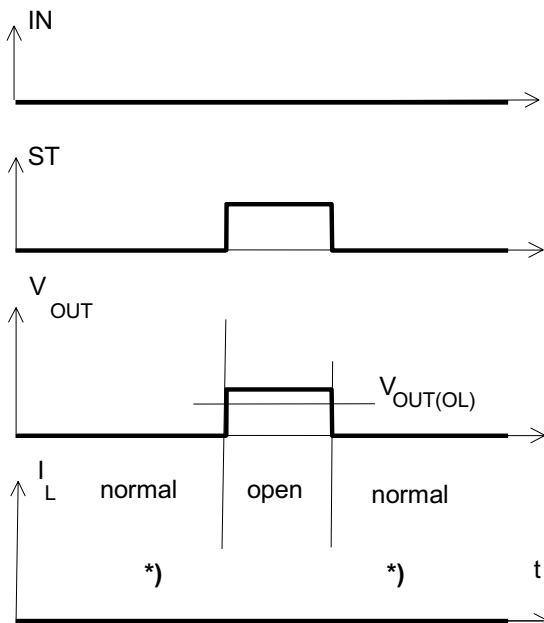
shut down by overtemperature, reset by cooling



**Figure 4a:** Overtemperature:  
Reset if  $T_j < T_{jt}$

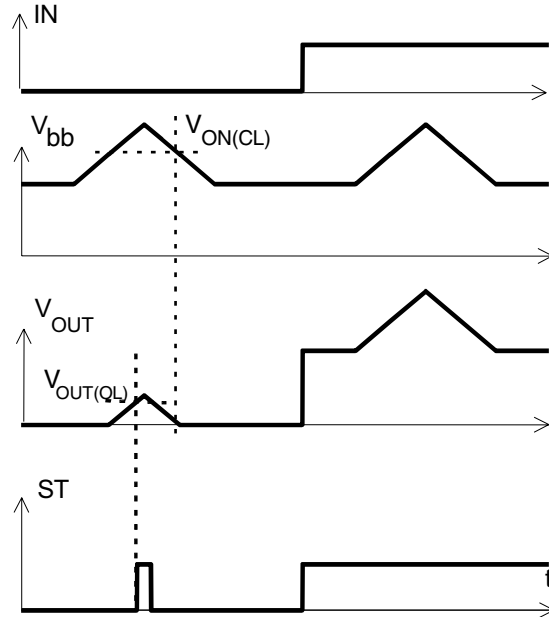


**Figure 5a:** Open load, : detection in OFF-state, open load occurs in off-state

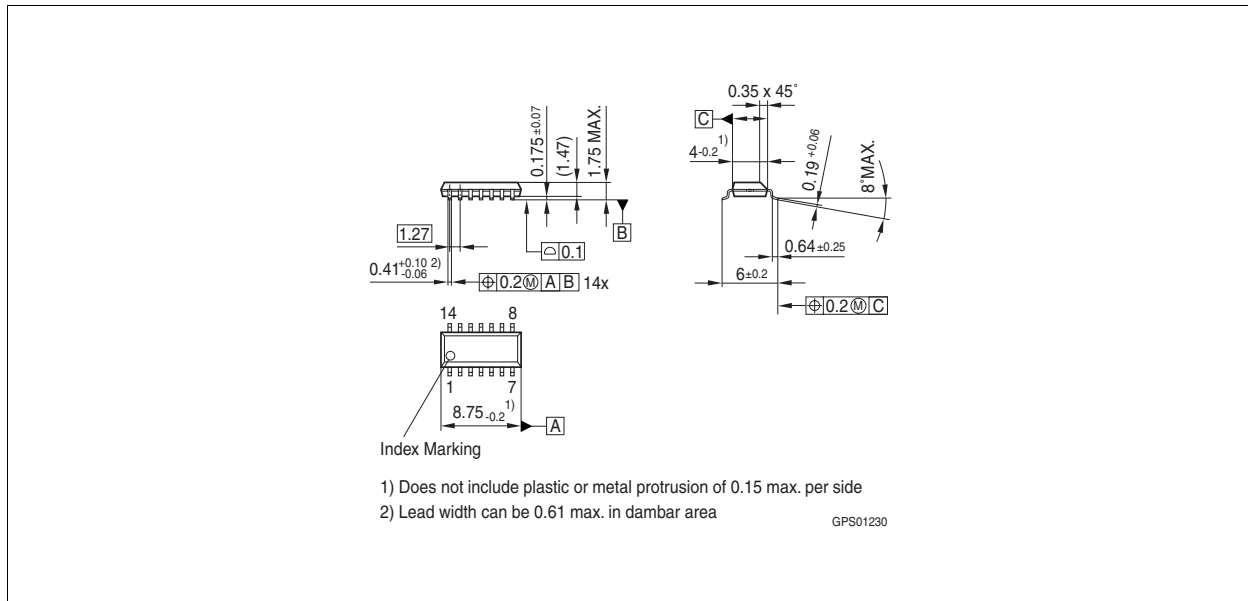


\*)  $I_L = 2 \mu\text{A typ. } V_{OUT} > 2.7\text{V}$

**Figure 6:** Overvoltage, no shutdown:



## Package Outlines



**Figure 1** PG-DSO-14-37 (Plastic Dual Small Outline Package) (RoHS-compliant)

To meet the world-wide customer requirements for environmentally friendly products and to be compliant with government regulations the device is available as a green product. Green products are RoHS-Compliant (i.e. Pb-free finish on leads and suitable for Pb-free soldering according to IPC/JEDEC J-STD-020).

Please specify the package needed (e.g. green package) when placing an order

## Revision History

Version	Date	Changes
V1.1	2007-09-25	Modification of the package drawing
V1.0	2007-05-25	Creation of the green datasheet. First page : Adding the green logo and the AEC qualified Adding the bullet AEC qualified and the RoHS compliant features Package page : Modification of the package to be green.



**Edition 2007-09-25**

**Published by  
Infineon Technologies AG  
81726 Munich, Germany**

**© Infineon Technologies AG 9/25/07.  
All Rights Reserved.**

### **Legal Disclaimer**

The information given in this document shall in no event be regarded as a guarantee of conditions or characteristics ("Beschaffheitsgarantie"). With respect to any examples or hints given herein, any typical values stated herein and/or any information regarding the application of the device, Infineon Technologies hereby disclaims any and all warranties and liabilities of any kind, including without limitation warranties of non-infringement of intellectual property rights of any third party.

### **Information**

For further information on technology, delivery terms and conditions and prices please contact your nearest Infineon Technologies Office ([www.infineon.com](http://www.infineon.com)).

### **Warnings**

Due to technical requirements components may contain dangerous substances. For information on the types in question please contact your nearest Infineon Technologies Office.

Infineon Technologies Components may only be used in life-support devices or systems with the express written approval of Infineon Technologies, if a failure of such components can reasonably be expected to cause the failure of that life-support device or system, or to affect the safety or effectiveness of that device or system. Life support devices or systems are intended to be implanted in the human body, or to support and/or maintain and sustain and/or protect human life. If they fail, it is reasonable to assume that the health of the user or other persons may be endangered.