

Smart Highside Power Switch

Reversave™

- Reverse battery protection by self turn on of power MOSFET

Features

- Short circuit protection
- Current limitation
- Overload protection
- Thermal shutdown
- Overvoltage protection (including load dump)
- Loss of ground protection
- Loss of V_{bb} protection (with external diode for charged inductive loads)
- Very low standby current
- Fast demagnetisation of inductive loads
- Electrostatic discharge (ESD) protection
- Optimized static electromagnetic compatibility (EMC)

Product Summary

Operating voltage	$V_{bb(on)}$	5.0 ... 36	V
On-state resistance	R_{ON}	16	mΩ
Load current (ISO)	$I_L(ISO)$	25	A
Current limitation	$I_L(SCr)$	65	A

Package

TO-252-5-1

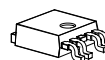

Diagnostic Function

- Proportional load current sense (with defined fault signal during thermal shutdown)

Application

- Power switch with current sense diagnostic feedback for 12V and 24 V DC grounded loads
- All types of resistive, capacitive and inductive loads (no PWM with inductive loads)
- Replaces electromechanical relays, fuses and discrete circuits

General Description

N channel vertical power FET with charge pump, current controlled input and diagnostic feedback with load current sense, integrated in Smart SiPMOS® chip on chip technology. Providing embedded protective functions.

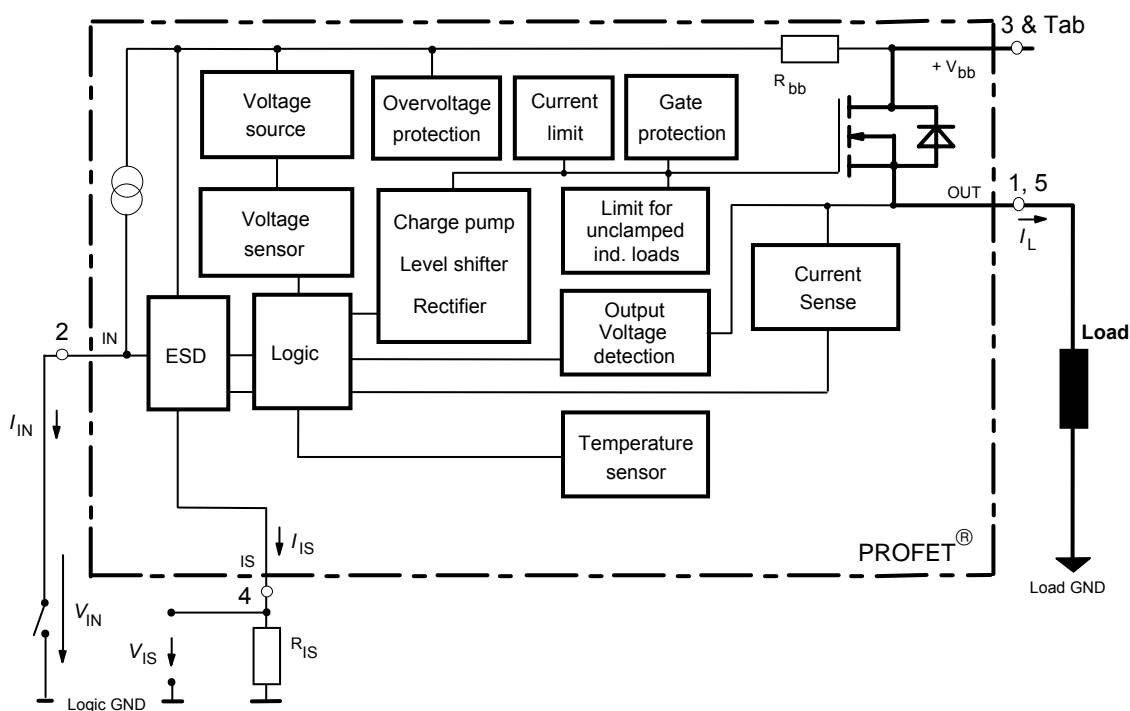

Pin	Symbol		Function
1	OUT	O	Output to the load. The pin 1 and 5 must be shorted with each other especially in high current applications!*)
2	IN	I	Input, activates the power switch in case of short to ground
Tab/(3)	V _{bb}	+	Positive power supply voltage, the tab is shorted to this pin.
4	IS	S	Diagnostic feedback providing a sense current proportional to the load current; high current on failure (see Truth Table on page 6)
5	OUT	O	Output to the load. The pin 1 and 5 must be shorted with each other especially in high current applications!*)

*) Not shorting all outputs will considerably increase the on-state resistance, reduce the peak current capability and decrease the current sense accuracy

Maximum Ratings at $T_j = 25\text{ °C}$ unless otherwise specified

Parameter	Symbol	Values	Unit
Supply voltage (overvoltage protection see page 4)	V_{bb}	36	V
Supply voltage for full short circuit protection (see also diagram on page 9) $T_j = -40 \dots 150\text{ °C}$:	V_{bb}	24 ¹⁾	V
Load dump protection $V_{LoadDump} = U_A + V_s$, $U_A = 13.5\text{ V}$ $R_l = 2\ \Omega$, $R_L = 2.7\ \Omega$, $t_d = 200\text{ ms}$, IN= low or high	$V_{Load\ dump}^{2)}$	60	V
Load current (Short-circuit current, see page 4)	I_L	self-limited	A
Operating temperature range	T_j	-40 ...+150	°C
Storage temperature range	T_{stg}	-55 ...+150	
Power dissipation (DC) $TC \leq 25\text{ °C}$	P_{tot}	42	W
Inductive load switch-off energy dissipation, single pulse $U=12\text{V}$, $I=10\text{A}$, $L=3\text{mH}$ $T_j=150\text{ °C}$:	E_{AS}	0.15	J
Electrostatic discharge capability (ESD) (Human Body Model) acc. ESD assn. std. S5.1-1993; $R=1.5\text{k}\Omega$; $C=100\text{pF}$	V_{ESD}	4.0	kV
Current through input pin (DC)	I_{IN}	+15, -100	mA
Current through current sense pin (DC) see internal circuit diagrams page 7	I_{IS}	+15, -100	

1) Short circuit is tested with $100\text{m}\Omega$ and $20\mu\text{H}$

2) $V_{Load\ dump}$ is set-up without the DUT connected to the generator per ISO 7637-1 and DIN 40839

Thermal Characteristics

Parameter and Conditions	Symbol	Values			Unit
		min	typ	max	
Thermal resistance chip - case: junction - ambient (free air): SMD version, device on PCB ⁴ :	$R_{thJC}^{3)}$	--	--	1.5	K/W
	R_{thJA}	--	80	--	
	R_{thJA}	--	45	--	

Electrical Characteristics

Parameter and Conditions at $T_j = -40^\circ\text{C} \dots 150^\circ\text{C}$, $V_{bb} = 12\text{ V}$ unless otherwise specified	Symbol	Values			Unit
		min	typ	max	

Load Switching Capabilities and Characteristics

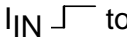
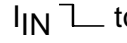
On-state resistance (pin 3 to pin 1,5) $V_{IN} = 0$, $I_L = 5\text{ A}$	R_{ON}	--	13	16	m Ω
$T_j = 25^\circ\text{C}$: $T_j = 150^\circ\text{C}$:			25	31	
Output voltage drop limitation at small load currents (Tab to pin 1,5) $T_j = -40 \dots 150^\circ\text{C}$:	$V_{ON(NL)}$	--	50	--	mV
Nominal load current (Tab to pin 1,5) ISO Proposal: $T_C = 85^\circ\text{C}$, $V_{ON} \leq 0.5\text{V}$, $T_j \leq 150^\circ\text{C}$ SMD ⁴): $T_A = 85^\circ\text{C}$, $V_{ON} \leq 0.5\text{V}$, $T_j \leq 150^\circ\text{C}$	$I_{L(ISO)}$ $I_{L(nom)}$	21 6.2	25 7.6	-- --	A
Turn-on time I_{IN}  to 90% V_{OUT} : $R_L = 2.5\Omega$, $T_j = -40 \dots 150^\circ\text{C}$	t_{on}	150	--	410	μs
Turn-off time I_{IN}  to 10% V_{OUT} : $R_L = 2.5\Omega$, $T_j = -40 \dots 150^\circ\text{C}$	t_{off}	70	--	410	
Slew rate on 10 to 30% V_{OUT} , $R_L = 2.5\Omega$, $T_j = -40 \dots 150^\circ\text{C}$	dV/dt_{on}	0.1	--	1	V/ μs
Slew rate off 70 to 40% V_{OUT} , $R_L = 2.5\Omega$, $T_j = -40 \dots 150^\circ\text{C}$	$-dV/dt_{off}$	0.1	--	1	V/ μs

3) Thermal resistance R_{thCH} case to heatsink (about 0.5 ... 0.9 K/W with silicone paste) not included!

4) Device on 50mm*50mm*1.5mm epoxy PCB FR4 with 6cm² (one layer, 70 μm thick) copper area for V_{bb} connection. PCB is vertical without blown air.

Parameter and Conditions at $T_j = -40^\circ\text{C} \dots 150^\circ\text{C}$, $V_{bb} = 12\text{ V}$ unless otherwise specified	Symbol	Values			Unit
		min	typ	max	

Operating Parameters

Operating voltage ($V_{IN}=0\text{V}$)	$V_{bb(on)}$	5.0	--	36	V
Undervoltage shutdown ⁵⁾	$V_{bIN(u)}$	1.5	3.0	4.5	V
Undervoltage restart of charge pump ($V_{IN}=0\text{V}$)	$V_{bb(ucp)}$	3.0	4.5	6.0	V
Overvoltage protection ⁶⁾ $I_{bb}=15\text{ mA}$	$V_{Z,IN}$	61	68	--	V
Standby current $I_{IN}=0$	$I_{bb(off)}$	$T_j = -40 \dots +25^\circ\text{C}$: $T_j = 150^\circ\text{C}$:	-- 2	5 8	μA

Protection Functions ⁷⁾

Short circuit current limit (Tab to pin 1,5) $V_{ON}=8\text{V}$, time until limitation max. 300 μs					
$T_j = -40^\circ\text{C}$: $T_j = 25^\circ\text{C}$: $T_j = +150^\circ\text{C}$:	$I_{L(SC)}$	35 35 35	75 65 65	110 110 125	A
Repetitive short circuit current limit, $T_j = T_{jt}$	$I_{L(SCr)}$	--	65	--	A
Output clamp (inductive load switch off) at $V_{OUT} = V_{bb} - V_{ON(CL)}$ (e.g. overvoltage) $I_L = 40\text{ mA}$ ⁸⁾	$V_{ON(CL)}$	38	42	48	V
Thermal overload trip temperature	T_{jt}	150	--	--	$^\circ\text{C}$
Thermal hysteresis	ΔT_{jt}	--	10	--	K

Reverse Battery

Reverse battery voltage	$-V_{bb}$	--	--	20	V
On-state resistance (pin 1,5 to pin 3) $V_{bb} = -8\text{V}$, $V_{IN} = 0$, $I_L = -5\text{ A}$, $R_{IS} = 1\text{ k}\Omega$, $T_j = 25^\circ\text{C}$: $V_{bb} = -12\text{V}$, $V_{IN} = 0$, $I_L = -5\text{ A}$, $R_{IS} = 1\text{ k}\Omega$, $T_j = 25^\circ\text{C}$: $T_j = 150^\circ\text{C}$:	$R_{ON(rev)}$	-- --	-- 16 25	22 19 32	$\text{m}\Omega$
Integrated resistor in V_{bb} line	R_{bb}	--	200	--	Ω

5) $V_{bIN}=V_{bb}-V_{IN}$ see diagram on page 11.

6) see also $V_{ON(CL)}$ in circuit diagram on page 7.

7) Integrated protection functions are designed to prevent IC destruction under fault condition described in the data sheet. Fault conditions are considered as "outside" normal operating range. Protection functions are not for continuous repetitive operation.

8) see also page 12.

Diagnostic Characteristics

Current sense ratio, static on-condition $k_{ILIS} = I_L : I_{IS}$ $V_{ON} < 1.5 V, V_{IS} < V_{OUT} - 5 V, V_{bIN} > 4.5 V$ ⁹⁾	k_{ILIS}	--	8200	--	
IL = 20A, T _j = -40°C:		7400	8300	9100	
T _j = +25°C:		7500	8300	9100	
T _j = +150°C:		7500	8200	8800	
IL = 5A, T _j = -40°C:		6800	8300	9700	
T _j = +25°C:		7200	8300	9300	
T _j = +150°C:		7200	8200	9000	
IL = 2.5A, T _j = -40°C:		6800	8500	10000	
T _j = +25°C:		6800	8500	9800	
T _j = +150°C:		6800	8100	9200	
IL = 1A, T _j = -40°C:		6800	8600	10500	
T _j = +25°C:		6800	8600	10500	
T _j = +150°C:		6800	8600	10500	
$I_{IN} = 0$ (e.g. during de-energising of inductive loads):		--	n.a.	--	
Sense current under fault conditions; $V_{DS} > 1.5 V$, typ. T _j = -40...+150°C:	$I_{IS, fault}$	2.5	4	--	mA
Fault-Sense signal delay after negative input slope	$t_{delay(fault)}$			0.8	ms
Current sense leakage current					
$I_{IN} = 0$: $I_{S(LL)}$		--	--	0.5	μA
$V_{IN} = 0, I_L = 0$: $I_{S(LH)}$		--	4	12	
Current sense settling time to $I_{IS} static \pm 10\%$ after positive input slope, $I_L = 0 \square 20 A$ ¹⁰⁾ T _j = -40...+150°C:	$t_{son(IS)}$	--	--	400	μs
Overvoltage protection $I_{bb} = 15 mA$ T _j = -40...+150°C:	$V_{bIS(Z)}$	61	68	--	V

Input

Required current capability of input switch T _j = -40...+150°C:	$I_{IN(on)}$	--	0.7	1.2	mA
Maximum input current for turn-off T _j = -40...+150°C:	$I_{IN(off)}$	--	--	50	μA

⁹⁾ If V_{ON} is higher, the sense current is no longer proportional to the load current due to sense current saturation.

¹⁰⁾ not subject to production test, specified by design

Truth Table

	Input Current level	Output level	Current Sense I_{IS}
Normal operation	L H	L H	0 nominal
Overload	L H	L H	0 $I_{ISfault}$
Short circuit to GND	L H	L L	0 $I_{ISfault}$
Overtemperature	L H	L L	0 $I_{ISfault}$
Short circuit to V_{bb}	L H	H H	0 <nominal ¹¹
Open load	L H	Z H	0 0

L = "Low" Level
H = "High" Level

Z = high impedance, potential depends on external circuit

Terms

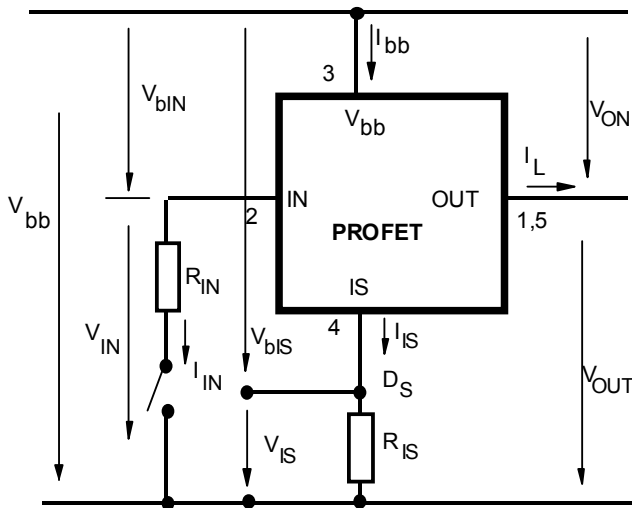

Two or more devices can easily be connected in parallel to increase load current capability.

¹¹⁾ Low ohmic short to V_{bb} may reduce the output current I_L and therefore also the sense current I_{IS} .

Input circuit (ESD protection)

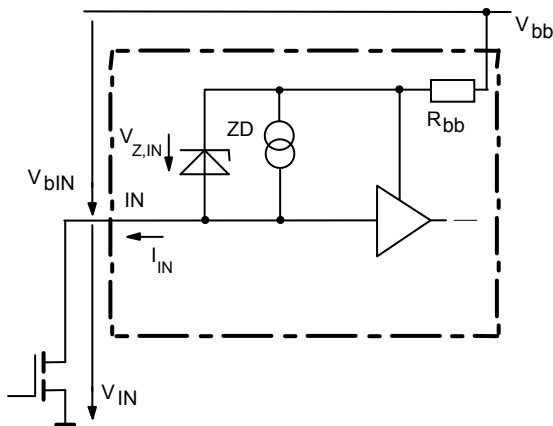

ESD-Zener diode: 68 V typ., max 15 mA;

Current sense output

Normal operation

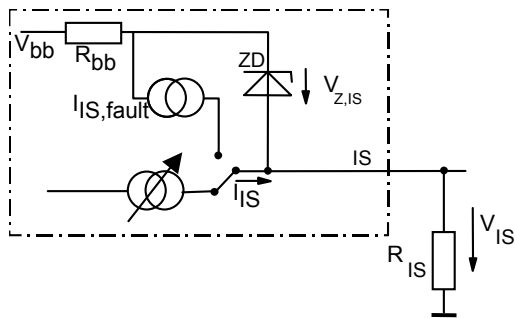

$V_{Z,IS} = 68V$ (typ.), $R_{IS} = 1\text{ k}\Omega$ nominal (or $1\text{ k}\Omega / n$, if n devices are connected in parallel). $I_S = I_L / K_{iis}$ can be only driven by the internal circuit as long as $V_{out} - V_{IS} > 5V$. If you want to measure load currents

up to $I_{L(M)}$, R_{IS} should be less than $\frac{V_{bb} - 5V}{I_{L(M)} / K_{iis}}$.

Note: For large values of R_{IS} the voltage V_{IS} can reach almost V_{bb} . See also overvoltage protection.

If you don't use the current sense output in your application, you can leave it open.

Inductive and overvoltage output clamp

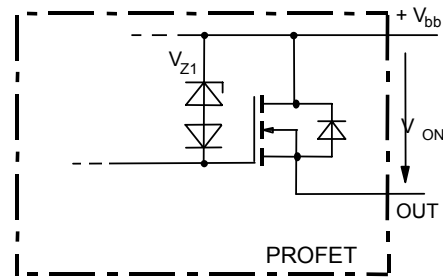

V_{ON} is clamped to $V_{ON(Cl)} = 42V$ typ.

Overvoltage protection of logic part

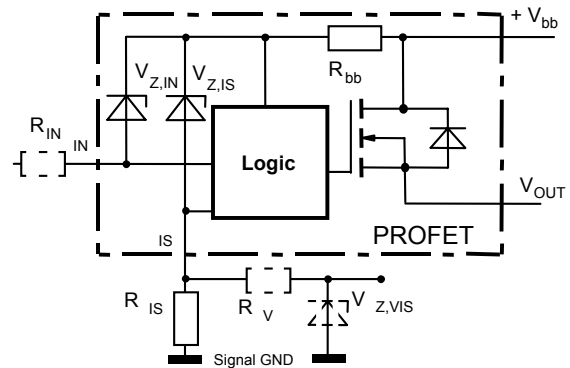

$R_{bb} = 200\Omega$ typ., $V_{Z,IN} = V_{Z,IS} = 68V$ typ., $R_{IS} = 1\text{ k}\Omega$ nominal. Note that when overvoltage exceeds 73V typ. a voltage above 5V can occur between IS and GND, if $R_V, V_{Z,VIS}$ are not used.

Reversave™ (Reverse battery protection)

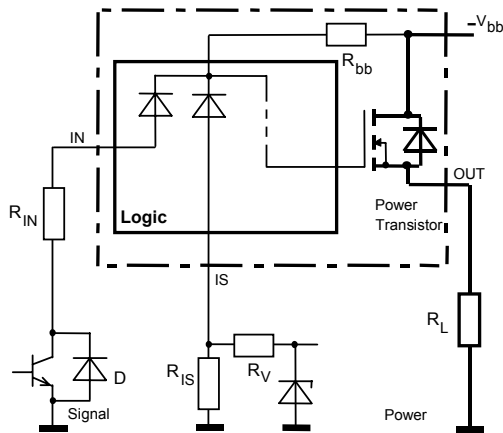

$R_V \geq 1k\Omega$, $R_{IS} = 1k\Omega$ nominal. Add R_{IN} for reverse battery protection in applications with V_{bb} above 16V; recommended value: $\frac{1}{R_{IN}} + \frac{1}{R_{IS}} + \frac{1}{R_V} = \frac{0.05A}{|V_{bb}|-12V}$

To minimise power dissipation at reverse battery operation, the summarised current into the IN and IS pin should be about 50mA. The current can be provided by using a small signal diode D in parallel to the input switch, by using a MOSFET input switch or by proper adjusting the current through R_{IS} and R_V . Since the current through R_{bb} generates additional heat in the device, this has to be taken into account in the overall thermal considerations.

V_{bb} disconnect with energised inductive load

Provide a current path with load current capability by using a diode, a Z-diode, or a varistor. ($V_{ZL} < 73V$ or $V_{Zb} < 30V$ if $R_{IN}=0$). For higher clamp voltages currents at IN and IS have to be limited to 250 mA.

Version a:

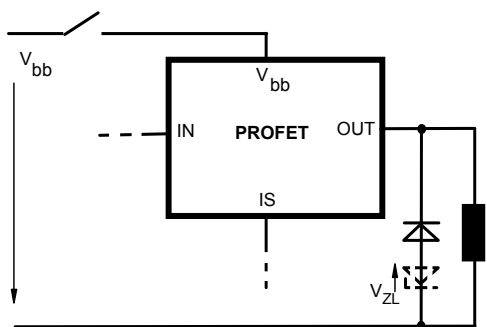

Version b:

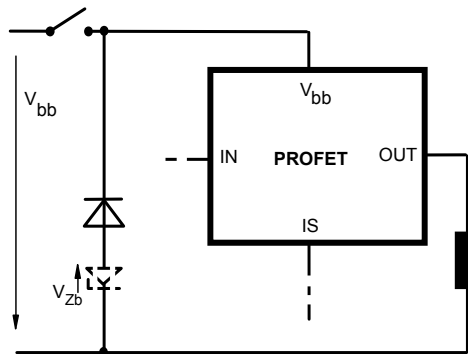

Note that there is no reverse battery protection when using a diode without additional Z-diode V_{ZL} , V_{Zb} .

Version c:

Sometimes a necessary voltage clamp is given by non inductive loads R_L connected to the same switch and eliminates the need of clamping circuit:

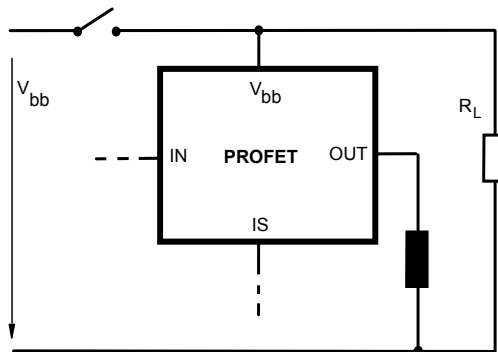

Inductive load switch-off energy dissipation

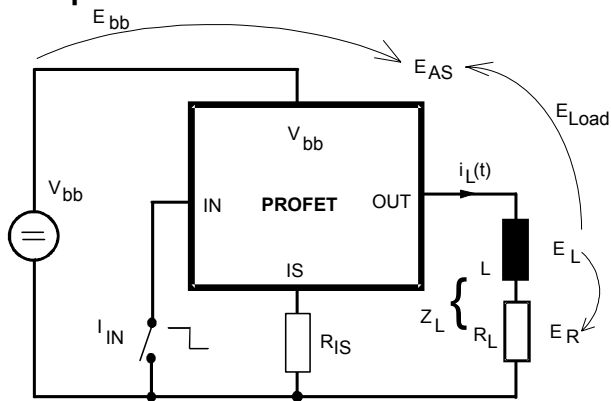

Energy stored in load inductance:

$$E_L = 1/2 \cdot L \cdot I_L^2$$

While demagnetising load inductance, the energy dissipated in PROFET is

$$E_{AS} = E_{bb} + E_L - E_R = V_{ON(CL)} \cdot \int i_L(t) dt,$$

with an approximate solution for $R_L > 0 \Omega$:

$$E_{AS} = \frac{I_L \cdot L}{2 \cdot R_L} (V_{bb} + |V_{OUT(CL)}|) \ln \left(1 + \frac{I_L \cdot R_L}{|V_{OUT(CL)}|} \right)$$

The device is not suitable for permanent PWM with inductive loads if active clamping occurs every cycle.

Maximum allowable load inductance for a single switch off

$L = f(I_L)$; $T_{j,start} = 150^\circ\text{C}$, $V_{bb} = 12\text{V}$, $R_L = 0 \Omega$

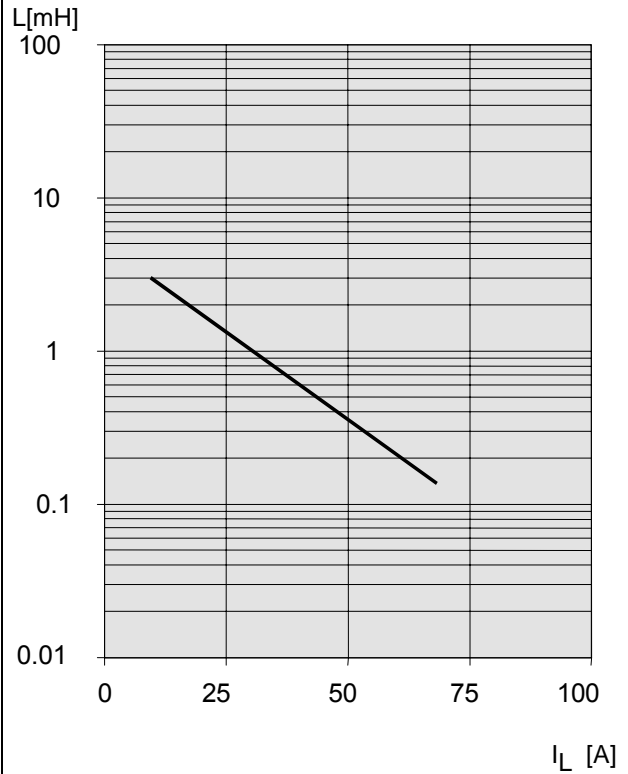

Timing diagrams

Figure 1a: Switching a resistive load, change of load current in on-condition:

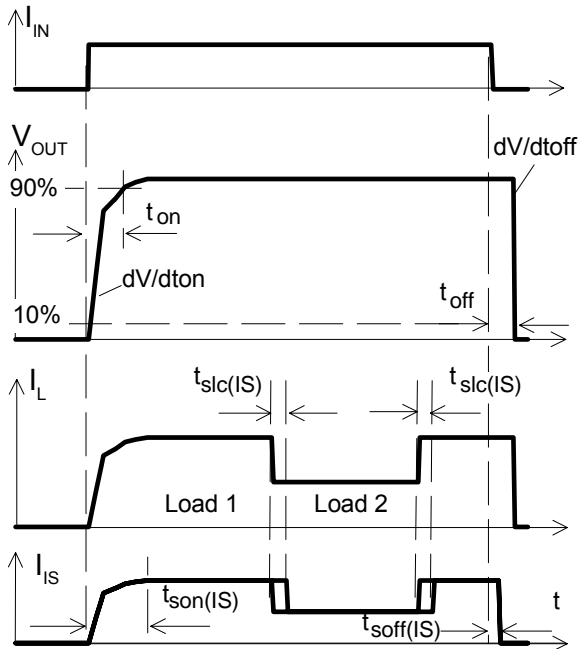

The sense signal is not valid during a settling time after turn-on/off and after change of load current.

Figure 1b: typical behaviour of sense output:

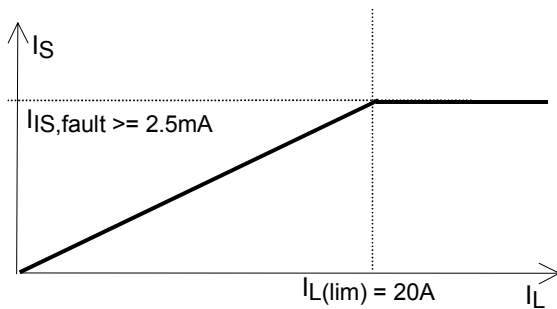
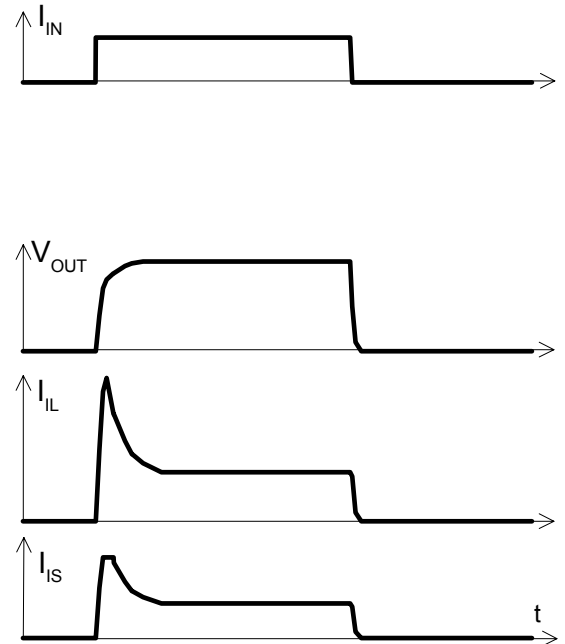

Figure 2a: Switching motors and lamps:



Sense current above $I_{IS,fault}$ can occur at very high inrush currents.

Figure 2b: Switching an inductive load:

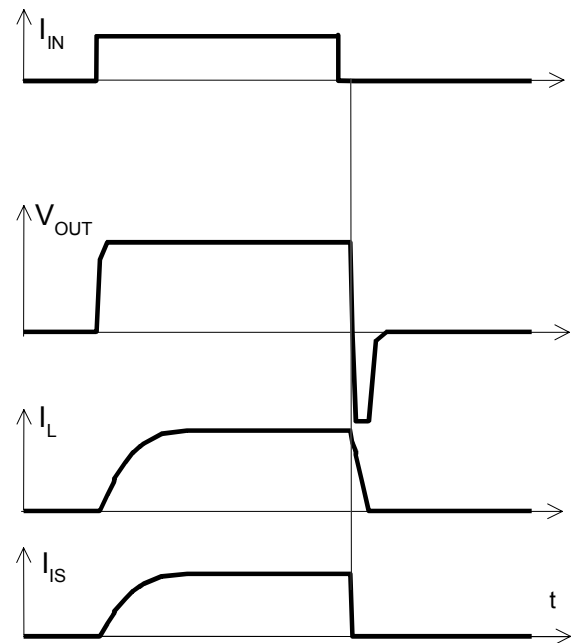

Figure 3a: Short circuit:

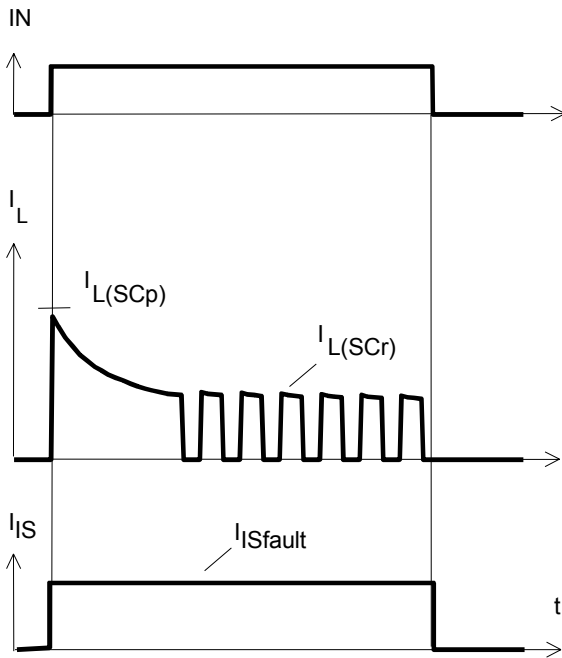

Figure 5a: Undervoltage restart of charge pump, overvoltage clamp

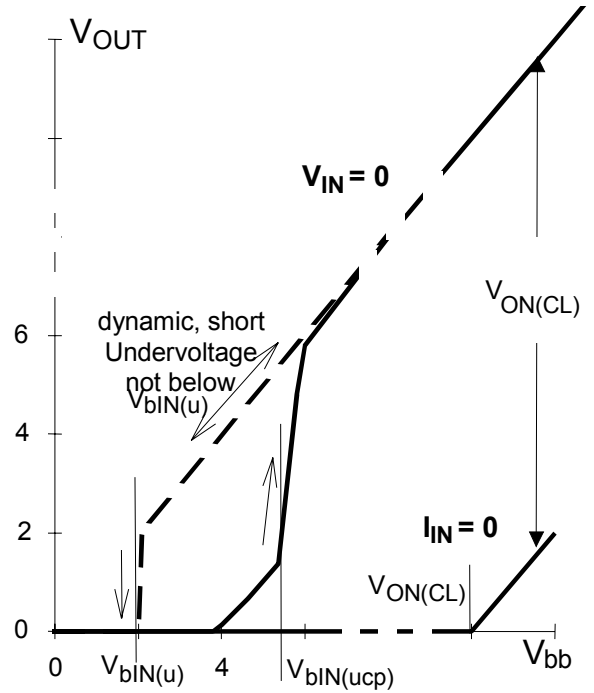

Figure 4a: Overtemperature Reset if $T_j < T_{jt}$

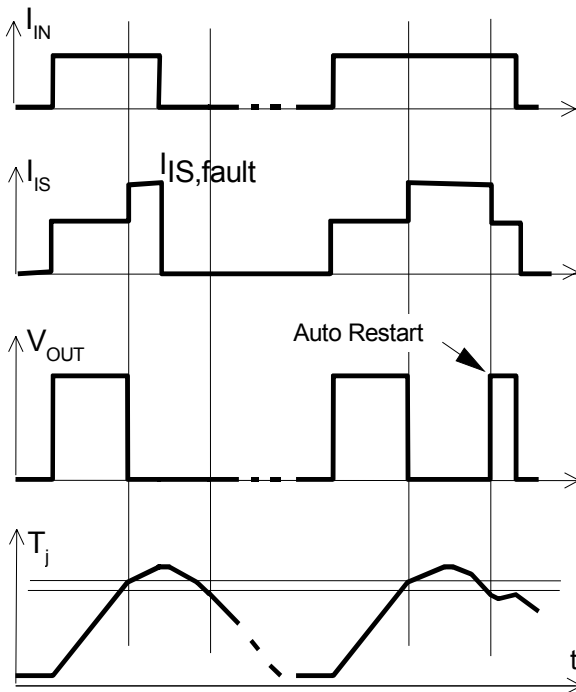

Figure 6a: Current sense versus load current:

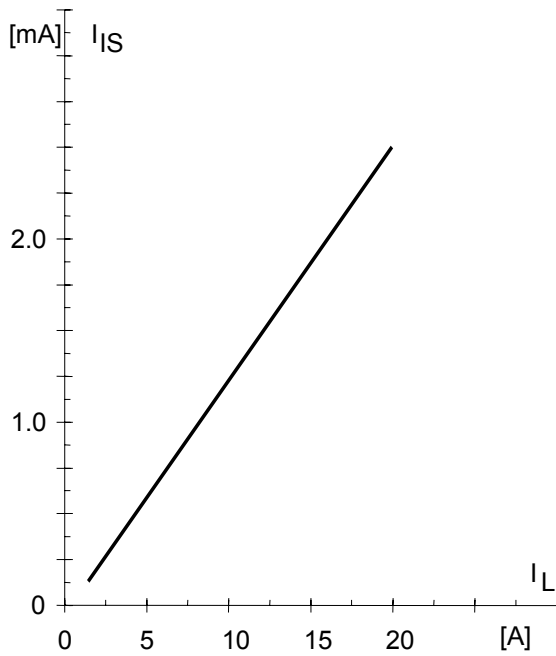

Figure 7a: Output voltage drop versus load current:

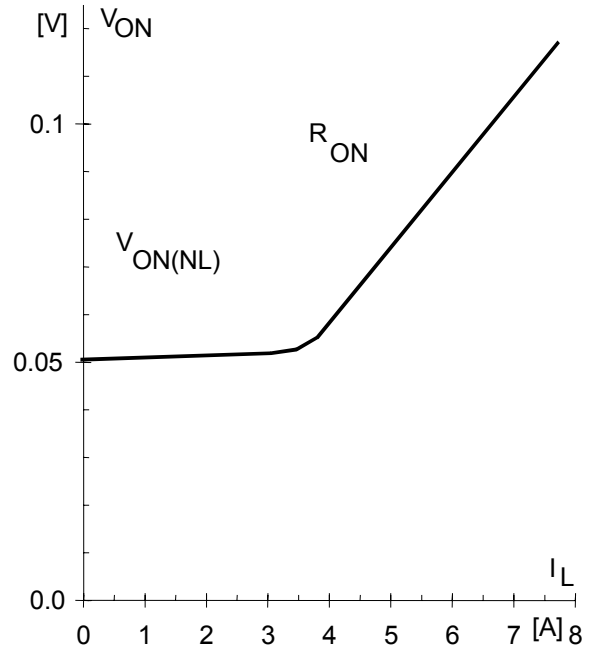
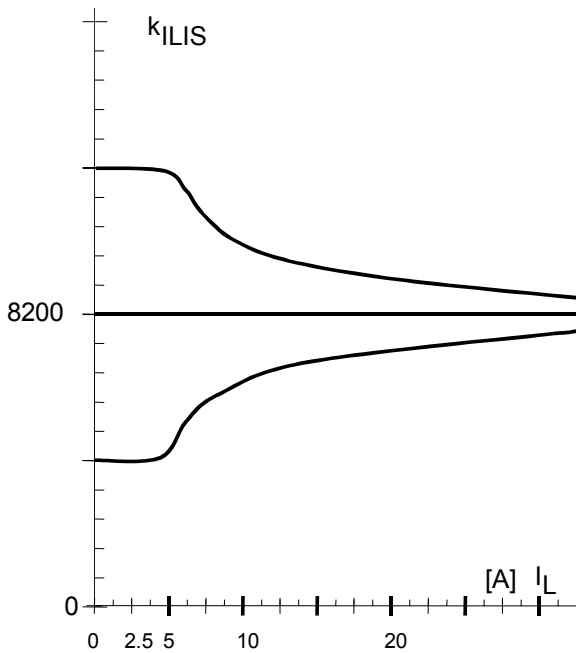

Figure 6b: Current sense ratio¹²⁾:



¹²⁾ This range for the current sense ratio refers to all devices. The accuracy of the k_{ILIS} can be raised by means of calibration the value of k_{ILIS} for every single device.

Package and Ordering Code

All dimensions in mm

D-Pak-5 Pin: TO-252-5-1

Sales Code	BTS443P
Ordering code	Q67060-S7404-A 2

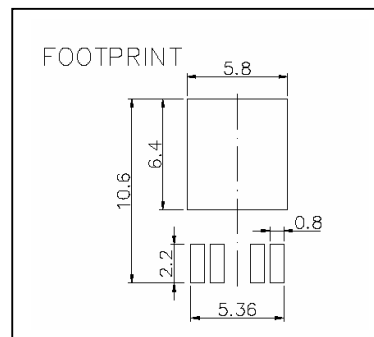
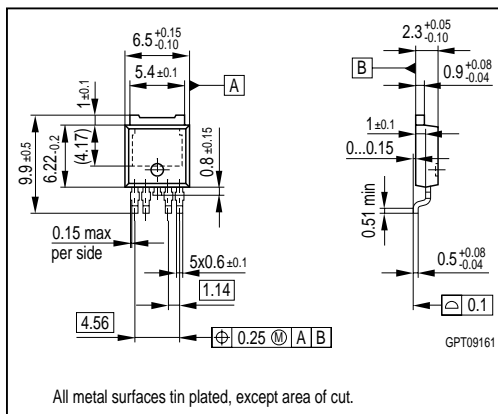

Published by
Infineon Technologies AG,
St.-Martin-Strasse 53,
D-81669 München
© Infineon Technologies AG 2001
All Rights Reserved.

Attention please!

The information herein is given to describe certain components and shall not be considered as a guarantee of characteristics.

Terms of delivery and rights to technical change reserved.

We hereby disclaim any and all warranties, including but not limited to warranties of non-infringement, regarding circuits, descriptions and charts stated herein.

Infineon Technologies is an approved CECC manufacturer.

Information

For further information on technology, delivery terms and conditions and prices please contact your nearest Infineon Technologies Office in Germany or our Infineon Technologies Representatives worldwide (see address list).

Warnings

Due to technical requirements components may contain dangerous substances. For information on the types in question please contact your nearest Infineon Technologies Office.

Infineon Technologies Components may only be used in life-support devices or systems with the express written approval of Infineon Technologies, if a failure of such components can reasonably be expected to cause the failure of that life-support device or system, or to affect the safety or effectiveness of that device or system. Life support devices or systems are intended to be implanted in the human body, or to support and/or maintain and sustain and/or protect human life. If they fail, it is reasonable to assume that the health of the user or other persons may be endangered.