ST-NXP Wireless

IMPORTANT NOTICE

Dear customer,

As from August 2nd 2008, the wireless operations of NXP have moved to a new company, ST-NXP Wireless.

As a result, the following changes are applicable to the attached document.

- **Company name - Philips Semiconductors** is replaced with **ST-NXP Wireless**.
- **Copyright** - the copyright notice at the bottom of each page "© Koninklijke Philips Electronics N.V. 200x. All rights reserved", shall now read: "© ST-NXP Wireless 200x - All rights reserved".
- **Web site** - <http://www.semiconductors.philips.com> is replaced with <http://www.stnwireless.com>
- **Contact information** - the list of sales offices previously obtained by sending an email to sales.addresses@www.semiconductors.philips.com, is now found at <http://www.stnwireless.com> under Contacts.

If you have any questions related to the document, please contact our nearest sales office. Thank you for your cooperation and understanding.

ST-NXP Wireless



ISP1581

Hi-Speed Universal Serial Bus peripheral controller

Rev. 06 — 23 December 2004

Product data

1. General description

The ISP1581 is a cost-optimized and feature-optimized Hi-Speed Universal Serial Bus (USB) peripheral controller, which fully complies with the *Universal Serial Bus Specification Rev. 2.0*. It provides high-speed USB communication capacity to systems based on a microcontroller or microprocessor. The ISP1581 communicates with the system's microcontroller/processor through a high-speed general-purpose parallel interface.

The ISP1581 supports automatic detection of Hi-Speed USB system operation. The Original USB fall-back mode allows the device to remain operational under full-speed conditions. It is designed as a generic USB peripheral controller so that it can fit into all existing device classes, such as: Imaging Class, Mass Storage Devices, Communication Devices, Printing Devices and Human interface devices.

The internal generic DMA block allows easy integration into data streaming applications. In addition, the various configurations of the DMA block are tailored for mass storage applications.

The modular approach to implementing a USB peripheral controller allows the designer to select the optimum system microcontroller from the wide variety available. The ability to re-use existing architecture and firmware investments shortens the development time, eliminates risk and reduces costs. The result is fast and efficient development of the most cost-effective USB peripheral solution.

The ISP1581 is ideally suited for many types of peripherals, such as: printers; scanners; magneto-optical (MO), compact disc (CD), digital video disc (DVD) and Zip®/Jaz® drives; digital still cameras; USB-to-Ethernet links; cable and DSL modems. The low power consumption during 'suspend' mode allows easy design of equipment that is compliant to the ACPI™, OnNow™ and USB power management requirements.

The ISP1581 also incorporates features such as SoftConnect™, a reduced frequency crystal oscillator and integrated termination resistors. These features allow significant cost savings in system design and easy implementation of advanced USB functionality into PC peripherals.



PHILIPS

2. Features

- Direct interface to ATA/ATAPI peripherals; applicable only in the split bus mode
- Complies fully with *Universal Serial Bus Specification Rev. 2.0*
- Complies with most Device Class specifications
- High performance USB peripheral controller with integrated Serial Interface Engine (SIE), PIE, FIFO memory, data transceiver and 3.3 V voltage regulators
- Supports automatic Hi-Speed USB mode detection and Original USB fall-back mode
- High-speed DMA interface (12.8 Mword/s)
- Fully autonomous and multi-configuration DMA operation
- 7 IN endpoints, 7 OUT endpoints and a fixed control IN/OUT endpoint
- Integrated physical 8 kbyte of multi-configuration FIFO memory
- Endpoints with double buffering to increase throughput and ease real-time data transfer
- Bus independent interface with most microcontroller/microprocessors (12.5 Mbyte/s)
- 12 MHz crystal oscillator with integrated PLL for low EMI
- Integrated 5 V-to-3 V built-in voltage regulator
- Software controlled connection to the USB bus (SoftConnect™)
- Complies with the ACPI™, OnNow™ and USB power management requirements
- Internal power-on and low-voltage reset circuit, also supporting a software reset
- Operation over the extended USB bus voltage range (4.0 to 5.5 V) with 5 V tolerant I/O pads
- Operating temperature range –40 to +85 °C
- Available in LQFP64 package.

3. Applications

- Personal Digital Assistant (PDA)
- Mass storage device, for example: Zip®, Jaz®, MO, CD, DVD drive
- Digital Video Camera
- Digital Still Camera
- 3G mobile phone
- MP3 player
- Communication device, for example: router, modem
- Printer
- Scanner.

4. Ordering information

Table 1: Ordering information

Type number	Package		
	Name	Description	Version
ISP1581BD	LQFP64	plastic low profile quad flat package; 64 leads; body 10 x 10 x 1.4 mm	SOT314-2

5. Block diagram

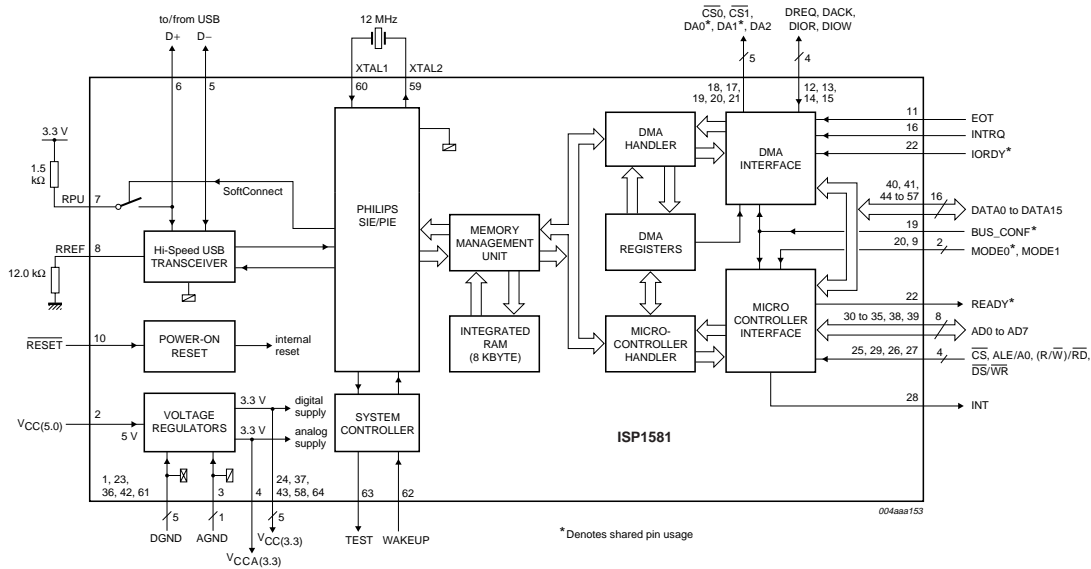

The direction of pins DREQ, DACK, DIOR and DIOV is determined by bit MASTER (DMA Hardware register) and bit ATA_MODE (DMA Configuration register).

Fig 1. Block diagram.

6. Pinning information

6.1 Pinning

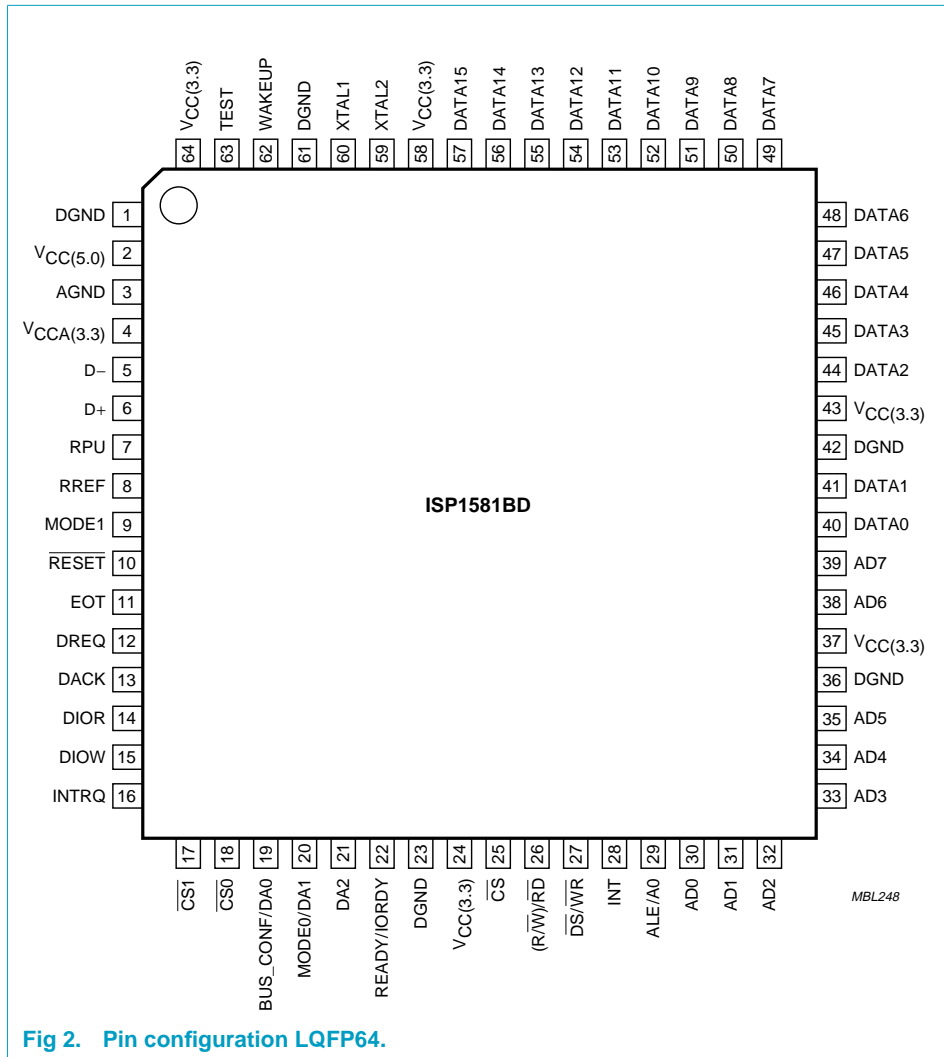

Fig 2. Pin configuration LQFP64.

6.2 Pin description

Table 2: Pin description for LQFP64

Symbol ^[1]	Pin	Type ^[2]	Description
DGND	1	-	digital ground
V _{CC(5.0)} ^[3]	2	-	supply voltage (3.3 or 5.0 V) for 5.0 V operation, this is the only pin used. Refer to Section 10
AGND	3	-	analog ground
V _{CCA(3.3)} ^[3]	4	-	regulated supply voltage (3.3 V ± 0.3 V) from internal regulator; supplies internal analog circuits; used to connect decoupling capacitor and 1.5 kΩ pull-up resistor on D+ line Remark: Cannot be used to supply external devices. Refer to Section 10
D-	5	A	USB D- connection (analog)
D+	6	A	USB D+ connection (analog)
RPU	7	A	connection for external pull-up resistor for USB D+ line; must be connected to V _{CCA(3.3)} via a 1.5 kΩ resistor
RREF	8	A	connection for external bias resistor; must be connected to ground via a 12.0 kΩ (± 1%) resistor
MODE1	9	I	selects function of pin ALE/A0 (in Split Bus mode only): 0 — ALE function (address latch enable) 1 — A0 function (address/data indicator). Remark: Connect to V _{CC(5.0)} in the Generic Processor mode. input pad; TTL; 5 V tolerant; internal pull-down resistor.
RESET	10	I	reset input; a LOW level produces an asynchronous reset; connect to V _{CC} for power-on reset (internal POR circuit) TTL with hysteresis; 5 V tolerant; internal pull-up resistor.
EOT	11	I	End Of Transfer input (programmable polarity, see Table 37); used in DMA slave mode only; when not in use, connect this pin to V _{CC(I/O)} through a 10 kΩ resistor input pad; TTL; 5 V tolerant; 5 ns slew rate control.
DREQ	12	I/O	DMA request (programmable polarity); direction depends on the bit MASTER in the DMA Hardware register (DMA master: input, DMA slave: output); see Table 35 and Table 36 ; when not in use, connect this pin to ground through a 10 kΩ resistor; bidirectional pad; push pull output; 5 ns slew rate control; TTL; 5 V tolerant.
DACK	13	I/O	DMA acknowledge (programmable polarity); direction depends on bit MASTER in the DMA Hardware register (DMA slave: input, DMA master: output); see Table 35 and Table 36 ; when not in use, connect this pin to V _{CC(I/O)} through a 10 kΩ resistor bidirectional pad; push pull output; 5 ns slew rate control; TTL; 5 V tolerant.

Table 2: Pin description for LQFP64 ...continued

Symbol ^[1]	Pin	Type ^[2]	Description
DIOR	14	I/O	DMA read strobe (programmable polarity); direction depends on bit MASTER in the DMA Hardware register (DMA slave: input, DMA master: output); see Table 35 and Table 36; when not in use, connect this pin to $V_{CC(I/O)}$ through a 10 k Ω resistor bidirectional pad; push pull output; 5 ns slew rate control; TTL; 5 V tolerant.
DIOW	15	I/O	DMA write strobe (programmable polarity); direction depends on bit MASTER in the DMA Hardware register (DMA slave: input, DMA master: output); see Table 35 and Table 36; when not in use, connect this pin to $V_{CC(I/O)}$ through a 10 k Ω resistor bidirectional pad; push pull output; 5 ns slew rate control; TTL; 5 V tolerant.
INTRQ	16	I	interrupt request input from ATA/ATAPI peripheral input pad; TTL with hysteresis; 5 V tolerant; internal pull-down resistor.
$\overline{CS1}$ ^[5]	17	O	chip select output for ATA/ATAPI device; see Table 33 and Table 34 CMOS output; 5 ns slew rate control
$\overline{CS0}$ ^[5]	18	O	chip select output for ATA/ATAPI device; see Table 33 and Table 34 CMOS output; 5 ns slew rate control
BUS_CONF/ DA0 ^[5]	19	I/O	during power-up: input to select the bus configuration; see Table 33 and Table 34 0 — Split Bus mode; multiplexed 8-bit address/data bus on AD[7:0], separate DMA data bus on DATA[15:0] ^[4] 1 — Generic Processor mode; separate 8-bit address on AD[7:0], 16-bit processor data bus on DATA[15:0]. DMA is multiplexed on the processor bus as DATA[15:0]. normal operation: address output to select the task file register of an ATA/ATAPI device. bidirectional pad; push pull output; 5 ns slew rate control; TTL; 5 V tolerant
MODE0 DA1 ^[5]	20	I/O	during power-up: input to select the read/write strobe functionality in generic processor mode; see Table 33 and Table 34 0 — Motorola style: pin 26 is R/\overline{W} and pin 27 is \overline{DS} 1 — 8051 style: pin 26 is \overline{RD} and pin 27 is \overline{WR} normal operation: address output to select the task file register of an ATA/ATAPI device bidirectional pad; push pull output; 5 ns slew rate control; TTL; 5 V tolerant
DA2 ^[5]	21	O	address output to select the task file register of an ATA/ATAPI device; see Table 33 and Table 34 CMOS output; 5 ns slew rate control

Table 2: Pin description for LQFP64 ...continued

Symbol ^[1]	Pin	Type ^[2]	Description
READY/ IORDY	22	I/O	<p>Generic processor mode: ready signal (READY; output) A LOW level signals that ISP1581 is processing a previous command or data and is not ready for the next command or data transfer; a HIGH level signals that ISP1581 is ready for the next microprocessor read or write.</p> <p>Split Bus mode: DMA ready signal (IORDY; input); used for accessing ATA/ATAPI peripherals (PIO and UDMA modes only).</p> <p>bidirectional pad; push pull output; 5 ns slew rate control; TTL; 5 V tolerant.</p>
DGND	23	-	digital ground
V _{CC(3.3)} ^[3]	24	-	supply voltage (3.3 V ± 0.3 V); supplies internal digital circuits or it is the tapped out voltage from the internal regulator; this regulated voltage cannot be used to drive external devices; see Section 10
\overline{CS}	25	I	chip select input; TTL; 5 V tolerant.
($\overline{R/W}$)/ \overline{RD}	26	I	<p>input; function is determined by input MODE0 at power-up:</p> <p>MODE0 = 0 — pin functions as $\overline{R/W}$ (Motorola style) MODE0 = 1 — pin functions as \overline{RD} (8051 style).</p> <p>input pad; TTL with hysteresis; 5 V tolerant.</p>
$\overline{DS}/\overline{WR}$	27	I	<p>input; function is determined by input MODE0 at power-up:</p> <p>MODE0 = 0 — pin functions as \overline{DS} (Motorola style) MODE0 = 1 — pin functions as \overline{WR} (8051 style).</p> <p>input pad; TTL with hysteresis; 5 V tolerant.</p>
INT	28	O	<p>interrupt output; programmable polarity (active HIGH or LOW) and signaling (edge or level triggered) CMOS output; 5 ns slew rate control.</p>
ALE/A0	29	I	<p>input; function determined by input MODE1 during power-up:</p> <p>MODE1 = 0 — pin functions as ALE (address latch enable); a falling edge latches the address on the multiplexed address/data bus (AD[7:0]) MODE1 = 1 — pin functions as A0 (address/data selection on AD[7:0]); a logic 1 detected on the rising edge of the \overline{WR} pulse qualifies AD[7:0] as a register address; a logic 0 detected on the rising edge of the \overline{WR} pulse qualifies AD[7:0] as a register data; used in Split Bus mode only.</p> <p>Remark: Connect to DGND in the Generic Processor mode.</p> <p>input pad; TTL; 5 V tolerant.</p>
AD0	30	I/O	<p>bit 0 of multiplexed address/data.</p> <p>bidirectional pad; push pull output; 5 ns slew rate control; TTL; 5 V tolerant.</p>

Table 2: Pin description for LQFP64 ...continued

Symbol ^[1]	Pin	Type ^[2]	Description
AD1	31	I/O	bit 1 of multiplexed address/data. bidirectional pad; push pull output; 5 ns slew rate control; TTL; 5 V tolerant.
AD2	32	I/O	bit 2 of multiplexed address/data. bidirectional pad; push pull output; 5 ns slew rate control; TTL; 5 V tolerant.
AD3	33	I/O	bit 3 of multiplexed address/data. bidirectional pad; push pull output; 5 ns slew rate control; TTL; 5 V tolerant.
AD4	34	I/O	bit 4 of multiplexed address/data. bidirectional pad; push pull output; 5 ns slew rate control; TTL; 5 V tolerant.
AD5	35	I/O	bit 5 of multiplexed address/data. bidirectional pad; push pull output; 5 ns slew rate control; TTL; 5 V tolerant.
DGND	36	-	digital ground
V _{CC(3.3)} ^[3]	37	-	supply voltage (3.3 V ± 0.3 V); supplies internal digital circuits or it is the tapped out voltage from the internal regulator; this regulated voltage cannot be used to drive external devices; see Section 10
AD6	38	I/O	bit 6 of multiplexed address/data. bidirectional pad; push pull output; 5 ns slew rate control; TTL; 5 V tolerant.
AD7	39	I/O	bit 7 of multiplexed address/data. bidirectional pad; push pull output; 5 ns slew rate control; TTL; 5 V tolerant.
DATA0	40	I/O	bit 0 of bidirectional data. bidirectional pad; push pull output; 5 ns slew rate control; TTL; 5 V tolerant.
DATA1	41	I/O	bit 1 of bidirectional data. bidirectional pad; push pull output; 5 ns slew rate control; TTL; 5 V tolerant.
DGND	42	-	digital ground
V _{CC(3.3)} ^[3]	43	-	supply voltage (3.3 V ± 0.3 V); supplies internal digital circuits or it is the tapped out voltage from the internal regulator; this regulated voltage cannot be used to drive external devices; see Section 10
DATA2	44	I/O	bit 2 of bidirectional data. bidirectional pad; push pull output; 5 ns slew rate control; TTL; 5 V tolerant.
DATA3	45	I/O	bit 3 of bidirectional data. bidirectional pad; push pull output; 5 ns slew rate control; TTL; 5 V tolerant.

Table 2: Pin description for LQFP64 ...continued

Symbol ^[1]	Pin	Type ^[2]	Description
DATA4	46	I/O	bit 4 of bidirectional data. bidirectional pad; push pull output; 5 ns slew rate control; TTL; 5 V tolerant.
DATA5	47	I/O	bit 5 of bidirectional data. bidirectional pad; push pull output; 5 ns slew rate control; TTL; 5 V tolerant.
DATA6	48	I/O	bit 6 of bidirectional data. bidirectional pad; push pull output; 5 ns slew rate control; TTL; 5 V tolerant.
DATA7	49	I/O	bit 7 of bidirectional data. bidirectional pad; push pull output; 5 ns slew rate control; TTL; 5 V tolerant.
DATA8	50	I/O	bit 8 of bidirectional data. bidirectional pad; push pull output; 5 ns slew rate control; TTL; 5 V tolerant.
DATA9	51	I/O	bit 9 of bidirectional data. bidirectional pad; push pull output; 5 ns slew rate control; TTL; 5 V tolerant.
DATA10	52	I/O	bit 10 of bidirectional data. bidirectional pad; push pull output; 5 ns slew rate control; TTL; 5 V tolerant.
DATA11	53	I/O	bit 11 of bidirectional data. bidirectional pad; push pull output; 5 ns slew rate control; TTL; 5 V tolerant.
DATA12	54	I/O	bit 12 of bidirectional data. bidirectional pad; push pull output; 5 ns slew rate control; TTL; 5 V tolerant.
DATA13	55	I/O	bit 13 of bidirectional data. bidirectional pad; push pull output; 5 ns slew rate control; TTL; 5 V tolerant.
DATA14	56	I/O	bit 14 of bidirectional data. bidirectional pad; push pull output; 5 ns slew rate control; TTL; 5 V tolerant.
DATA15	57	I/O	bit 15 of bidirectional data. bidirectional pad; push pull output; 5 ns slew rate control; TTL; 5 V tolerant.
V _{CC(3.3)} ^[3]	58	-	supply voltage (3.3 V ± 0.3 V); supplies internal digital circuits or it is the tapped out voltage from the internal regulator; this regulated voltage cannot be used to drive external devices; see Section 10
XTAL2	59	O	crystal oscillator output (12 MHz); connect a fundamental parallel-resonant crystal; leave this pin open when using an external clock source on pin XTAL1
XTAL1	60	I	crystal oscillator input (12 MHz); connect a fundamental parallel-resonant crystal or an external clock source (leaving pin XTAL2 unconnected)

Table 2: Pin description for LQFP64 ...continued

Symbol ^[1]	Pin	Type ^[2]	Description
DGND	61	-	digital ground
WAKEUP	62	I	wake-up input (edge triggered); a LOW-to-HIGH transition generates a remote wake-up from 'suspend' state. input pad; TTL with hysteresis; with internal pull-down resistor; 5 V tolerant; internal pull-down resistor.
TEST	63	O	test output; this pin is used for test purposes only
V _{CC(3.3)} ^[3]	64	-	supply voltage (3.3 V ± 0.3 V); supplies internal digital circuits or it is the tapped out voltage from the internal regulator; this regulated voltage cannot be used to drive external devices; see Section 10

[1] Symbol names with an overscore (for example, $\overline{\text{NAME}}$) represent active LOW signals.

[2] All outputs and I/O pins can source 4 mA of current.

[3] Add a decoupling capacitor (0.1 μF) to all the supply pins. For better EMI results, add a 0.01 μF capacitor in parallel to the 0.1 μF .

[4] The DMA bus is in three-state until a DMA command (see [Section 9.4.1](#)) is executed.

[5] The control signals are not three-state.

7. Functional description

The ISP1581 is a high-speed USB device controller. It implements the Hi-Speed USB and Original USB physical layer, the packet protocol layer and maintains up to 16 USB endpoints concurrently (control IN and control OUT, 7 IN and 7 OUT configurable) along with Endpoint EPOSETUP, which is used to access the setup buffer. *USB Chapter 9* protocol handling is executed by means of external firmware.

The ISP1581 has a fast general-purpose interface for communication with most types of microcontrollers/processors. This Microcontroller Interface is configured by pins BUS_CONF, MODE1 and MODE0 to accommodate most interface types. Two bus configurations are available, selected via input BUS_CONF during power-up:

- **Generic Processor mode (BUS_CONF = 1):**
 - AD[7:0]: 8-bit address bus (selects target register)
 - DATA[15:0]: 16-bit data bus (shared by processor and DMA)
 - Control signals: $R\overline{W}$ and \overline{DS} or \overline{RD} and \overline{WR} (selected via pin MODE0), \overline{CS}
 - DMA interface (generic slave mode only): uses lines DATA[15:0] as data bus, DIOR and DIOW as dedicated read and write strobes.
- **Split Bus mode (BUS_CONF = 0):**
 - AD[7:0]: 8-bit local microprocessor bus (multiplexed address/data)
 - DATA[15:0]: 16-bit DMA data bus
 - Control signals: \overline{CS} , ALE or A0 (selected via pin MODE1), $R\overline{W}$ and \overline{DS} or \overline{RD} and \overline{WR} (selected via pin MODE0)
 - DMA interface (master or slave mode): uses DIOR and DIOW as dedicated read and write strobes.

For high-bandwidth data transfer, the integrated DMA handler can be invoked to transfer data to/from external memory or devices. The DMA Interface can be configured by writing to the proper DMA registers (see [Section 9.4](#)).

The ISP1581 supports Hi-Speed USB and Original USB signaling. Detection of the USB signaling speed is done automatically.

ISP1581 has 8 kbytes of internal FIFO memory, which is shared among the enabled USB endpoints.

There are 7 IN endpoints, 7 OUT endpoints and 2 control endpoints that are a fixed 64 bytes long. Any of the 7 IN and 7 OUT endpoints can be separately enabled or disabled. The endpoint type (interrupt, isochronous or bulk) and packet size of these endpoints can be individually configured depending on the requirements of the application. Optional double buffering increases the data throughput of these data endpoints.

The ISP1581 requires a single supply of 3.3 V or 5.0 V, depending on the I/O voltage. It has 5.0 V tolerant I/O pads and has an internal 3.3 V regulator for powering the analog transceiver.

The ISP1581 operates on a 12 MHz crystal oscillator. An integrated 40× PLL clock multiplier generates the internal sampling clock of 480 MHz.

7.1 Hi-Speed USB transceiver

The analog transceiver interfaces directly to the USB cable via integrated termination resistors. The high-speed transceiver requires an external resistor ($12.0\text{ k}\Omega \pm 1\%$) between pin RREF and ground to ensure an accurate current mirror that is used to generate the Hi-Speed USB current drive. A full-speed transceiver is integrated as well. This makes the ISP1581 compliant with Hi-Speed USB and Original USB, supporting both the high-speed and full-speed physical layer. After automatic speed detection, the Philips Serial Interface Engine sets the transceiver to use either high-speed or full-speed signaling.

7.2 Philips Serial Interface Engine (SIE)

The Philips SIE implements the full USB protocol layer. It is completely hardwired for speed and needs no firmware intervention. The functions of this block include: synchronization pattern recognition, parallel/serial conversion, bit (de-)stuffing, CRC checking/generation, Packet IDentifier (PID) verification/generation, address recognition, handshake evaluation/generation.

7.3 Philips HS (High-Speed) Transceiver

7.3.1 Philips Parallel Interface Engine

In the HS Transceiver, the Philips PIE interface uses a 16 bit Parallel bi-directional data interface. The functions of the HS (High-speed) module also include Bit-stuffing/De-stuffing and NRZI Encoding/Decoding logic.

7.3.2 Peripheral circuit

To maintain a constant current driver for HS (High-Speed) transmit circuits and to bias other analog circuits, an internal band-gap reference circuit and RREF resistor are used to form the reference current. This circuit requires an external precision resistor ($12.0\text{ k}\Omega \pm 1\%$) connected to analog ground.

7.3.3 HS detection

ISP1581 handles more than one electrical state (FS/HS) under the USB specification. When the USB cable is connected from the device to the host controller, at first the device ISP1581 defaults to the Full-speed (FS) state until it sees a bus reset from the host controller.

During the bus reset, the device initiates a HS chirp to detect whether the host-controller supports Hi-Speed USB or Original USB. Chirping must be done with the pull-up resistor connected and the internal termination resistors disabled. If the HS handshake shows that there is a HS host connected, then ISP1581 switches to the HS state.

In HS state, the ISP1581 observes the bus for periodic activity. If the bus remains inactive for 3 ms, the device switches to the FS state to check for an SE0 (Single-ended zero) condition on the USB bus. If an SE0 condition is detected for the designated time window ($100\text{ }\mu\text{s}$ to $875\text{ }\mu\text{s}$, see Section 7.1.7.6 of the USB specification Rev. 2.0), the ISP1581 switches to the HS chirp state again to do a HS detection handshake. Otherwise, the ISP1581 remains in the FS state adhering to the bus-suspend specification.

7.4 Voltage regulators

Two 5 V-to-3.3 V voltage regulators are integrated on-chip to separately supply the analog transceiver and the internal logic. The output of these voltage regulators are termed as $V_{CCA(3.3)}$ and $V_{CC(3.3)}$ to distinguish them as being used for the analog block and the digital block, respectively. The pin $V_{CCA(3.3)}$ is also used to supply an external 1.5 k Ω pull-up resistor on the D+ line.

Remark: Pins $V_{CCA(3.3)}$ and $V_{CC(3.3)}$ cannot be used to supply external devices.

7.5 Memory Management Unit (MMU) and integrated RAM

The MMU and the integrated RAM provide the conversion between the USB speed (full-speed: 12 Mbit/s, high-speed: 480 Mbit/s) and the Microcontroller Handler or the DMA Handler. The data from the USB Bus is stored in the integrated RAM, which is cleared only when the microcontroller has read/written all data from/to the corresponding endpoint buffer or when the DMA Handler has read/written all data from/to the endpoint buffer. The endpoint buffer can also be cleared forcibly by setting the CLBUF bit in the control function register. A total of 8 kbytes RAM is available for buffering.

7.6 SoftConnect

The connection to the USB is established by pulling the D+ line (for full-speed devices) HIGH through a 1.5 k Ω pull-up resistor. In the ISP1581 an external 1.5 k Ω pull-up resistor must be connected between pins RPU and $V_{CCA(3.3)}$. The RPU pin connects the pull-up resistor to the D+ line, when bit SOFTCT in the Mode register is set (see Table 7). After a hardware reset the pull-up resistor is disconnected by default (SOFTCT = 0). Bit SOFTCT remains unchanged by a USB bus reset.

7.7 Microcontroller/Processor Interface and Microcontroller/Processor Handler

The Microcontroller Interface allows direct interfacing to most microcontrollers. The interface is configured at power-up via inputs BUS_CONF, MODE1 and MODE0.

When BUS_CONF is set to logic 1, the Microcontroller Interface switches to the **Generic Processor mode** in which AD[7:0] is the 8-bit address bus and DATA[15:0] is the separate 16-bit data bus. If BUS_CONF is made logic 0, the interface is in the **Split Bus mode**, where AD[7:0] is the local microprocessor bus (multiplexed address/data) and DATA[15:0] is solely used as the DMA bus.

If pin MODE0 is set to logic 1, pins \overline{RD} and \overline{WR} are the read and write strobes (8051 style). If pin MODE0 is logic 0, pins R/\overline{W} and \overline{DS} pins represent the direction and data strobe (Motorola style).

When pin MODE1 is made logic 0, ALE is used to latch the multiplexed address on pins AD[7:0]. If pin MODE1 is set to logic 1, A0 is used to indicate address or data. Pin MODE1 is only used in Split Bus mode: in Generic Processor mode it must be tied to $V_{CC(5.0)}$ (logic 1).

The Microcontroller Handler allows the external microcontroller to access the register set in the Philips SIE as well as the DMA Handler. The initialization of the DMA configuration is done via the Microcontroller Handler.

7.8 DMA Interface and DMA Handler

The DMA block can be subdivided into two blocks: the DMA Handler and the DMA Interface.

The firmware writes to the DMA Command register to start a DMA transfer (see [Table 28](#)). The command opcode determines whether a generic DMA, PIO, MDMA or UDMA transfer will start. The Handler interfaces to the same FIFO (internal RAM) as used by the USB core. Upon receiving the DMA Command, the DMA Handler directs the data from the internal RAM to the external DMA device or from the external DMA device to the internal RAM.

The DMA Interface configures the timings and the DMA handshake. Data can be transferred either using DIOR and DIOV strobes or by the DACK and DREQ handshakes. The different DMA configurations are set up by writing to the DMA Configuration register (see [Table 33](#) and [Table 34](#)).

For an IDE-based storage interface, the applicable DMA modes are PIO (Parallel I/O), MDMA (Multi word DMA; ATA), and UDMA (Ultra DMA; ATA).

For a generic DMA interface, the DMA modes that can be used are Generic DMA (Slave) and MDMA (Master).

7.9 Power-on reset

The ISP1581 requires a minimum pulse width of 500 μ s.

The $\overline{\text{RESET}}$ pin can be either connected to $V_{\text{CC}(3.3)}$ using the internal POR circuit or externally controlled by the microcontroller, ASIC, and so on. When $V_{\text{CC}(3.3)}$ is directly connected to the $\overline{\text{RESET}}$ pin, the internal pulse width t_{PORP} will be typically 200 ns.

The power-on reset function can be explained by viewing the dips at t_2 – t_3 and t_4 – t_5 on the $V_{\text{CC}(3.3)}$ curve ([Figure 3](#)).

t_0 — The internal POR starts with a HIGH level.

t_1 — The detector will see the passing of the trip level and a delay element will add another t_{PORP} before it drops to LOW.

t_2 – t_3 — The internal POR pulse will be generated whenever $V_{\text{CC}(3.3)}$ drops below V_{trip} for more than 11 μ s.

t_4 – t_5 — The dip is too short ($< 11 \mu$ s) and the internal POR pulse will not react and will remain LOW.

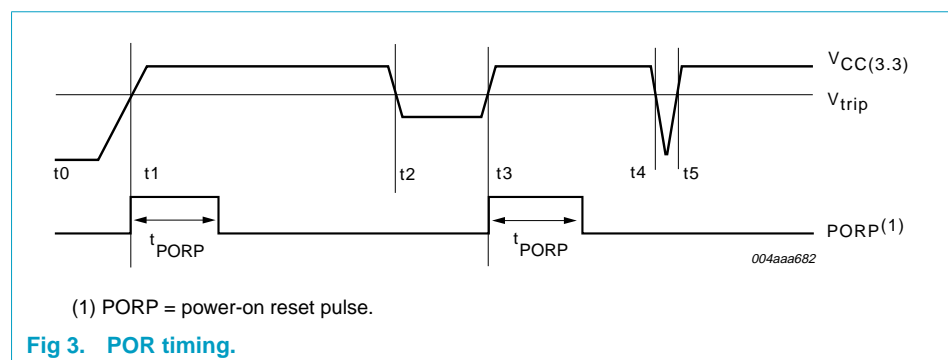
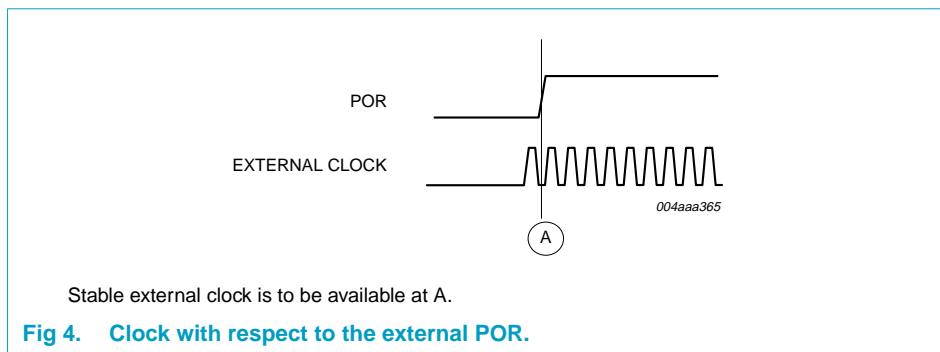

Figure 4 shows the availability of the clock with respect to the external POR.



8. Modes of operation

The ISP1581 has two bus configuration modes, selected via pin BUS_CONF/DA0 at power-up:

- **Split Bus mode (BUS_CONF = 0):** 8-bit multiplexed address/data bus and separate 8-bit/16-bit DMA bus
- **Generic Processor mode (BUS_CONF = 1):** separate 8-bit address and 16-bit data bus

Details of the bus configurations for each mode are given in [Table 3](#). Typical interface circuits for each mode are given in [Section 15](#).

Table 3: Bus configuration modes

BUS_CONF	PIO width	DMA width		Description
		DMAWD = 0	DMAWD = 1	
0	AD[7:0]	D[7:0]	D[15:0]	Split Bus mode: multiplexed address/data on pins AD[7:0]; separate 8/16-bit DMA bus on pins DATA[15:0]
1	A[7:0] D[15:0]	D[7:0]	D[15:0]	Generic Processor mode: separate 8-bit address on pins AD[7:0]; 16-bit data (PIO and DMA) on pins DATA[15:0]

9. Register descriptions

Table 4: Register overview

Name	Destination	Address (Hex)	Description	Size (bytes)
Initialization registers				
Address	device	00	USB device address + enable	1
Mode	device	0C	power-down options, global interrupt enable, SoftConnect	1
Interrupt Configuration	device	10	interrupt sources, trigger mode, output polarity	1
Interrupt Enable	device	14	interrupt source enabling	4
DMA Configuration	DMA controller	38	see sub-section "DMA registers"	2
DMA Hardware	DMA controller	3C	see sub-section "DMA registers"	1
Data flow registers				
Endpoint Index	endpoints	2C	endpoint selection, data flow direction	1
Control Function	endpoint	28	endpoint buffer management	1
Data Port	endpoint	20	data access to endpoint FIFO	2
Buffer Length	endpoint	1C	packet size counter	2
Endpoint MaxPacketSize	endpoint	04	maximum packet size	2
Endpoint Type	endpoint	08	selects endpoint type: control, isochronous, bulk or interrupt	2
Short Packet	endpoint	24	short packet received on OUT endpoint	2

Table 4: Register overview...continued

Name	Destination	Address (Hex)	Description	Size (bytes)
DMA registers				
DMA Command	DMA controller	30	controls all DMA transfers	1
DMA Transfer Counter	DMA controller	34	sets byte count for DMA Transfer	4
DMA Configuration	DMA controller	38 (byte 0)	sets GDMA configuration (counter enable, burst length, data strobing, bus width)	1
		39 (byte 1)	sets ATA configuration (IORDY enable, mode selection: ATA/UDMA/MDMA/PIO)	1
DMA Hardware	DMA controller	3C	endian type, master/slave selection, signal polarity for DACK, DREQ, DIOW, DIOR	1
1F0 Task File	ATAPI peripheral	40	single address word register: byte 0 (lower byte) is accessed first	2
1F1 Task File	ATAPI peripheral	48	IDE device access	1
1F2 Task File	ATAPI peripheral	49	IDE device access	1
1F3 Task File	ATAPI peripheral	4A	IDE device access	1
1F4 Task File	ATAPI peripheral	4B	IDE device access	1
1F5 Task File	ATAPI peripheral	4C	IDE device access	1
1F6 Task File	ATAPI peripheral	4D	IDE device access	1
1F7 Task File	ATAPI peripheral	44	IDE device access (write only; reading returns FFH)	1
3F6 Task File	ATAPI peripheral	4E	IDE device access	1
		4F	IDE device access	1
DMA Interrupt Reason	DMA controller	50 (byte 0)	shows reason (source) for DMA interrupt	1
		51 (byte 1)		1
DMA Interrupt Enable	DMA controller	54 (byte 0)	enables DMA interrupt sources	1
		55 (byte 1)		1
DMA Endpoint	DMA controller	58	selects endpoint FIFO, data flow direction	1
DMA Strobe Timing	DMA controller	60	strobe duration in UDMA/MDMA mode	1
General registers				
Interrupt	device	18	shows interrupt sources	4
Chip ID	device	70	product ID code and hardware version	3
Frame Number	device	74	last successfully received Start Of Frame: lower byte (byte 0) is accessed first	2
Scratch	device	78	allows save/restore of firmware status during 'suspend'	2
Test Mode	PHY	84	direct setting of D+, D- states, internal transceiver test (PHY)	1

9.1 Register access

Register access depends on the bus width used:

- **8-bit bus:** multi-byte registers are accessed lower byte (LSByte) first.
- **16-bit bus:** for single-byte registers the upper byte (MSByte) must be ignored.

Endpoint specific registers are indexed via the Endpoint Index register. The target endpoint must be selected first, before accessing the following registers:

- Buffer Length
- Control Function
- Data Port
- Endpoint MaxPacketSize
- Endpoint Type
- Short Packet.

Remark: All reserved bits are not implemented. The bus and bus reset values are not defined. Therefore, writing to these reserved bits will have no effect.

9.2 Initialization registers

9.2.1 Address register (address: 00H)

This register is used to set the USB assigned address and enable the USB device. [Table 5](#) shows the Address register bit allocation.

The DEVEN and DEVADDR bits will be cleared whenever a bus reset, a power-on reset or a soft reset occurs.

In response to the standard USB request SET_ADDRESS, the firmware must write the (enabled) device address to the Address register, followed by sending an empty packet to the host. The **new** device address is activated when the host acknowledges the empty packet.

Table 5: Address register: bit allocation

Bit	7	6	5	4	3	2	1	0
Symbol	DEVEN	DEVADDR[6:0]						
Reset	0	00H						
Bus reset	0	00H						
Access	R/W	R/W						

Table 6: Endpoint Configuration register: bit description

Bit	Symbol	Description
7	DEVEN	A logic 1 enables the device.
6 to 0	DEVADDR[6:0]	This field specifies the USB device address.

9.2.2 Mode register (address: 0CH)

This register consists of 1 byte (bit allocation: see Table 7). In 16-bit bus mode the upper byte is ignored.

The Mode register controls the resume, suspend and wake-up behavior, interrupt activity, soft reset, clock signals and SoftConnect operation.

Table 7: Mode register: bit allocation

Bit	7	6	5	4	3	2	1	0
Symbol	CLKAON	SNDRSU	GOSUSP	SFRESET	GLINTENA	WKUPCS	reserved	SOFTCT
Reset	0	0	0	0	0	0	-	0
Bus reset	0	0	0	0	unchanged	0	-	unchanged
Access	R/W	R/W	R/W	R/W	R/W	R/W	-	R/W

Table 8: Mode register: bit description

Bit	Symbol	Description
7	CLKAON	Clock Always On: A logic 1 indicates that the internal clocks are always running even during 'suspend' state. A logic 0 switches off the internal oscillator and PLL, when they are not needed. During 'suspend' state, this bit must be set to logic 0 to meet the suspend current requirements. The clock is stopped after a delay of approximately 2 ms, following the setting of bit GOSUSP.
6	SNDRSU	Send Resume: Writing a logic 1 followed by a logic 0 will generate an upstream 'resume' signal of 10 ms duration, after a 5 ms delay.
5	GOSUSP	Go Suspend: Writing a logic 1 followed by a logic 0 will activate 'suspend' mode.
4	SFRESET	Soft Reset: Writing a logic 1 followed by a logic 0 will enable a software-initiated reset to ISP1581. A soft reset is similar to a hardware-initiated reset (via the $\overline{\text{RESET}}$ pin).
3	GLINTENA	Global Interrupt Enable: A logic 1 enables all interrupts. Individual interrupts can be masked OFF by clearing the corresponding bits in the Interrupt Enable register. Bus reset value: unchanged.
2	WKUPCS	Wake-up on Chip Select: A logic 1 enables remote wake-up via a LOW level on input $\overline{\text{CS}}$.
1	-	reserved; must write logic 0
0	SOFTCT	SoftConnect: A logic 1 enables the connection of the 1.5 k Ω pull-up resistor on pin RPU to the D+ line. Bus reset value: unchanged.

9.2.3 Interrupt Configuration register (address: 10H)

This 1-byte register determines the behavior and polarity of the INT output. The bit allocation is shown in Table 9. When the USB SIE receives or generates a ACK, NAK or STALL, it will generate interrupts depending on three Debug mode bit fields:

- CDBGMOD[1:0]: interrupts for the Control endpoint 0
- DDBGMODIN[1:0]: interrupts for the DATA IN endpoints 1 to 7

- DDBGMODOUT[1:0]: interrupts for the DATA OUT endpoints 1 to 7.

The Debug mode settings for CDBGMOD, DDBGMODIN and DDBGMODOUT allow the user to individually configure when the ISP1581 will send an interrupt to the external microprocessor. Table 11 lists the available combinations.

Bit INTPOL controls the signal polarity of the INT output (active HIGH or LOW, rising or falling edge). For level-triggering bit INTLVL must be made logic 0. By setting INTLVL to logic 1 an interrupt will generate a pulse of 60 ns (edge-triggering).

Table 9: Interrupt Configuration register: bit allocation

Bit	7	6	5	4	3	2	1	0
Symbol	CDBGMOD[1:0]		DDBGMODIN[1:0]		DDBGMODOUT[1:0]		INTLVL	INTPOL
Reset	03H		03H		03H		0	0
Bus reset	03H		03H		03H		unchanged	unchanged
Access	R/W		R/W		R/W		R/W	R/W

Table 10: Interrupt Configuration register: bit description

Bit	Symbol	Description
7 to 6	CDBGMOD[1:0]	Control 0 Debug Mode: values see Table 11
5 to 4	DDBGMODIN[1:0]	Data Debug Mode IN: values see Table 11
3 to 2	DDBGMODOUT[1:0]	Data Debug Mode OUT: values see Table 11
1	INTLVL	Interrupt Level: selects the signaling mode on output INT (0 = level, 1 = pulsed). In pulsed mode an interrupt produces a 60 ns pulse. Bus reset value: unchanged.
0	INTPOL	Interrupt Polarity: selects signal polarity on output INT (0 = active LOW, 1 = active HIGH). Bus reset value: unchanged.

Table 11: Debug mode settings

Value	CDBGMOD	DDBGMODIN	DDBGMODOUT
00H	Interrupt on all ACK and NAK	Interrupt on all ACK and NAK	Interrupt on all ACK, NYET and NAK
01H	Interrupt on all ACK.	Interrupt on ACK	Interrupt on ACK and NYET
1XH	Interrupt on all ACK and first NAK ^[1]	Interrupt on all ACK and first NAK ^[1]	Interrupt on all ACK, NYET and first NAK ^[1]

[1] First NAK: the first NAK on an IN or OUT token after a previous ACK response.

9.2.4 Interrupt Enable register (address: 14H)

This register enables/disables individual interrupt sources. The interrupt for each endpoint can be individually controlled via the associated IEPnRX or IEPnTX bits ('n' representing the endpoint number). All interrupts can be globally disabled via bit GLINTENA in the Mode Register (see Table 7).

An interrupt is generated when the USB SIE receives or generates an ACK or NAK on the USB bus. The interrupt generation depends on the Debug mode settings of bit fields CDBGMOD, DDBGMODIN and DDBGMODOUT.

All data IN transactions use the Transmit buffers (TX), which are handled by the DDBGMODIN bits. All data OUT transactions go via the Receive buffers (RX), which are handled by the DDBGMODOUT bits. Transactions on Control endpoint 0 (IN, OUT and SETUP) are handled by the CDBGMOD bits.

Interrupts caused by events on the USB bus (SOF, Pseudo SOF, suspend, resume, bus reset, Setup and High-Speed Status) can also be controlled individually. A bus reset disables all enabled interrupts except bit IEBRST (bus reset), which remains unchanged.

The Interrupt Enable Register consists of 4 bytes. The bit allocation is given in [Table 12](#).

Table 12: Interrupt Enable register: bit allocation

Bit	31	30	29	28	27	26	25	24
Symbol	reserved						IEP7TX	IEP7RX
Reset	-	-	-	-	-	-	0	0
Bus Reset	-	-	-	-	-	-	0	0
Access	R/W	R/W	R/W	R/W	R/W	R/W	R/W	R/W
Bit	23	22	21	20	19	18	17	16
Symbol	IEP6TX	IEP6RX	IEP5TX	IEP5RX	IEP4TX	IEP4RX	IEP3TX	IEP3RX
Reset	0	0	0	0	0	0	0	0
Bus Reset	0	0	0	0	0	0	0	0
Access	R/W	R/W	R/W	R/W	R/W	R/W	R/W	R/W
Bit	15	14	13	12	11	10	9	8
Symbol	IEP2TX	IEP2RX	IEP1TX	IEP1RX	IEP0TX	IEP0RX	reserved	IEP0SETUP
Reset	0	0	0	0	0	0	-	0
Bus Reset	0	0	0	0	0	0	-	0
Access	R/W	R/W	R/W	R/W	R/W	R/W	R/W	R/W
Bit	7	6	5	4	3	2	1	0
Symbol	reserved	IEDMA	IEHS_STA	IERESM	IESUSP	IEPSOF	IESOF	IEBRST
Reset	-	0	0	0	0	0	0	0
Bus Reset	-	0	0	0	0	0	0	unchanged
Access	R/W	R/W	R/W	R/W	R/W	R/W	R/W	R/W

Table 13: Interrupt Enable register: bit description

Bit	Symbol	Description
31 to 26	-	reserved; must write logic 0
25 to 12	IEP7TX to IEP1RX	A logic 1 enables interrupt from the indicated endpoint.
11	IEP0TX	A logic 1 enables interrupt from the Control IN endpoint 0.
10	IEP0RX	A logic 1 enables interrupt from the Control OUT endpoint 0.
9	-	reserved
8	IEP0SETUP	A logic 1 enables the interrupt for the Setup data received on endpoint 0.
7	-	reserved

Table 13: Interrupt Enable register: bit description...continued

Bit	Symbol	Description
6	IEDMA	A logic 1 enables interrupt upon DMA status change detection.
5	IEHS_STA	A logic 1 enables interrupt upon detection of a High Speed Status change.
4	IERESM	A logic 1 enables interrupt upon detection of a 'resume' state.
3	IESUSP	A logic 1 enables interrupt upon detection of a 'suspend' state.
2	IEPSOF	A logic 1 enables interrupt upon detection of a Pseudo SOF.
1	IESOF	A logic 1 enables interrupt upon detection of an SOF.
0	IEBRST	A logic 1 enables interrupt upon detection of a bus reset.

9.2.5 DMA Configuration register (address: 38H)See [Section 9.4.3](#).**9.2.6 DMA Hardware register (address: 3CH)**See [Section 9.4.4](#).**9.3 Data flow registers****9.3.1 Endpoint Index register (address: 2CH)**

The Endpoint Index register selects a target endpoint for register access by the microcontroller. The register consists of 1 byte and the bit allocation is shown in [Table 14](#). The following registers are indexed:

- Endpoint MaxPacketSize
- Endpoint Type
- Buffer Length
- Data Port
- Short Packet
- Control Function.

For example, to access the OUT data buffer of endpoint 1 via the Data Port register, the Endpoint Index register has to be written first with 02H.

Table 14: Endpoint Index register: bit allocation

Bit	7	6	5	4	3	2	1	0
Symbol	reserved		EPOSETUP	ENDPIDX[3:0]				DIR
Reset	-	-	0	00H				0
Bus reset	unchanged							
Access	R/W	R/W	R/W	R/W				R/W

Table 15: Endpoint Index register: bit description

Bit	Symbol	Description
7 to 6	-	reserved
5	EPOSETUP	Selects the SETUP buffer for Endpoint 0: 0 — EP0 data buffer 1 — SETUP buffer. Must be logic 0 for access to other endpoints than Endpoint 0.
4 to 1	ENDPIDX[3:0]	Endpoint Index: Selects the target endpoint for register access of Buffer Length, Control Function, Data Port, Endpoint Type, MaxPacketSize and Short Packet.
0	DIR	Direction bit: Sets the target endpoint as IN or OUT endpoint: 0 — target endpoint refers to OUT (RX) FIFO 1 — target endpoint refers to IN (TX) FIFO.

Table 16: Addressing of Endpoint 0 buffers

Buffer name	EPOSETUP	ENDPIDX	DIR
SETUP	1	00H	0
Data OUT	0	00H	0
Data IN	0	00H	1

9.3.2 Control Function register (address: 28H)

The Control Function register is used to perform the buffer management on the endpoints. It consists of 1 byte and the bit configuration is given in Table 17. The register bits can stall, clear or validate any enabled data endpoint. Before accessing this register, the Endpoint Index register must be written first to specify the target endpoint.

Table 17: Control Function register: bit allocation

Bit	7	6	5	4	3	2	1	0
Symbol		reserved		CLBUF	VENDP	reserved	STATUS ^[1]	STALL
Reset	-	-	-	0	0	-	0	0
Bus reset	-	-	-	0	0	-	0	0
Access	R/W	R/W	R/W	R/W	R/W	R/W	R/W	R/W

[1] Only applicable for control IN/OUT.

Table 18: Control Function register: bit description

Bit	Symbol	Description
7 to 5	-	reserved.
4	CLBUF	Clear Buffer: A logic 1 clears the RX buffer of the indexed endpoint; the TX buffer is not affected. The RX buffer is cleared automatically once the endpoint is read completely. This bit is set only when it is necessary to forcefully clear the buffer.
3	VENDP	Validate Endpoint: A logic 1 validates the data in the TX FIFO of an IN endpoint for sending on the next IN token. In general, the endpoint is validated automatically when its FIFO byte count has reached the endpoint MaxPacketSize. This bit is set only when it is necessary to validate the endpoint with the FIFO byte count which is below the Endpoint MaxPacketSize.
2	-	reserved
1	STATUS	Status Acknowledge: This bit controls the generation of ACK or NAK during the status stage of a SETUP transfer. It is automatically cleared upon completion of the status stage and upon receiving a SETUP token: 0 — sends NAK 1 — sends empty packet following IN token (host-to-device) or ACK following OUT token (device-to-host).
0	STALL	Stall Endpoint: A logic 1 stalls the indexed endpoint. This bit is not applicable for isochronous transfers. Note: 'Stalling' a data endpoint will confuse the Data Toggle bit about the stalled endpoint because the internal logic picks up from where it is stalled. Therefore, the Data Toggle bit must be reset by disabling and re-enabling the corresponding endpoint (by setting the bit 'ENABLE' to 0 or 1 in the endpoint type register) to reset the PID.

9.3.3 Data Port register (address: 20H)

This 2-byte register provides direct access for a microcontroller to the FIFO of the indexed endpoint. In case of an 8-bit bus the upper byte is not used. The bit allocation is shown in [Table 19](#).

Device to host (IN endpoint): After each write action an internal counter is auto-incremented (by 2 for a 16-bit access, by 1 for an 8-bit access) to the next location in the TX FIFO. When all bytes have been written (FIFO byte count = endpoint MaxPacketSize), the buffer is validated automatically. The data packet will then be sent on the next IN token. When it is necessary to validate the endpoint whose byte count is less than the MaxPacketSize, it can be done via the control function register (bit VENDP).

Host to device (OUT endpoint): After each read action an internal counter is auto-decremented (by 2 for a 16-bit access, by 1 for an 8-bit access) to the next location in the RX FIFO. When all bytes have been read, the buffer contents are cleared automatically. A new data packet can then be received on the next OUT token. The buffer contents can also be cleared via the Control Function register (bit CLBUF), when it is necessary to forcefully clear the contents.

Remark: The buffer can be validated or cleared automatically by using the Buffer Length register (see [Table 21](#)).

Table 19: Data Port register: bit allocation

Bit	15	14	13	12	11	10	9	8
Symbol	DATAPORT[15:8]							
Reset	00H							
Bus reset	00H							
Access	R/W							
Bit	7	6	5	4	3	2	1	0
Symbol	DATAPORT[7:0]							
Reset	00H							
Bus reset	00H							
Access	R/W							

Table 20: Data Port register: bit description

Bit	Symbol	Description
15 to 8	DATAPORT[15:8]	data (upper byte); not used in 8-bit bus mode
7 to 0	DATAPORT[7:0]	data (lower byte)

9.3.4 Buffer Length register (address: 1CH)

This 2-byte register determines the current packet size (DATACOUNT) of the indexed endpoint FIFO. The bit allocation is given in [Table 21](#).

The Buffer Length register is automatically loaded with the FIFO size, when the Endpoint MaxPacketSize register is written (see [Table 22](#)). A smaller value can be written when required. After a bus reset the Buffer Length register is made zero.

IN endpoint: When data transfer is performed in multiples of MaxPacketSize, the Buffer Length register is not significant. This register is useful only when transferring data that is not a multiple of MaxPacketSize. The following two examples demonstrate the significance of the Buffer Length register.

Example 1: Consider that the transfer size is 512 bytes and the MaxPacketSize is programmed as 64 bytes, the Buffer Length register need not be filled. This is because the transfer size is a multiple of MaxPacketSize, and the MaxPacketSize packets will be automatically validated because the last packet is also of MaxPacketSize.

Example 2: Consider that the transfer size is 510 bytes and the MaxPacketSize is programmed as 64 bytes, the Buffer Length register should be filled with 62 bytes just before the MCU writes the last packet of 62 bytes. This ensures that the last packet, which is a short packet of 62 bytes, is automatically validated.

This is only applicable to the PIO mode access.

OUT endpoint: The DATACOUNT value is automatically initialized to the number of data bytes sent by the host on each ACK.

Remark: When using a 16-bit microprocessor bus, the last byte of an odd-sized packet is output as the lower byte (LSByte).

Table 21: Buffer Length register: bit allocation

Bit	15	14	13	12	11	10	9	8
Symbol	DATACOUNT[15:8]							
Reset	00H							
Bus reset	00H							
Access	R/W							
Bit	7	6	5	4	3	2	1	0
Symbol	DATACOUNT[7:0]							
Reset	00H							
Bus reset	00H							
Access	R/W							

9.3.5 Endpoint MaxPacketSize register (address: 04H)

This register determines the maximum packet size for all endpoints except Control 0. The register contains 2 bytes and the bit allocation is given in Table 22.

Each time the register is written, the Buffer Length registers of all endpoints are re-initialized to the FFOSZ field value. The NTRANS bits control the number of transactions allowed in a single micro-frame (for high-speed Isochronous and interrupt endpoints only).

Table 22: Endpoint MaxPacketSize register: bit allocation

Bit	15	14	13	12	11	10	9	8
Symbol	reserved			NTRANS[1:0]			FFOSZ[10:8]	
Reset	-	-	-	00H			00H	
Bus reset	-	-	-	00H			00H	
Access	R/W	R/W	R/W	R/W			R/W	
Bit	7	6	5	4	3	2	1	0
Symbol	FFOSZ[7:0]							
Reset	00H							
Bus reset	00H							
Access	R/W							

Table 23: Endpoint MaxPacketSize register: bit description

Bit	Symbol	Description
15 to 13	reserved	reserved
12 to 11	NTRANS[1:0]	Number of Transactions (HS mode only): <ul style="list-style-type: none"> 0 — 1 packet per microframe 1 — 2 packets per microframe 2 — 3 packets per microframe 3 — reserved. These bits are applicable for Isochronous/interrupt transactions only.
10 to 0	FFOSZ[10:0]	FIFO Size: Sets the FIFO size in bytes for the indexed endpoint. Applies to both HS and FS operation.

9.3.6 Endpoint Type register (address: 08H)

This register sets the Endpoint type of the indexed endpoint: isochronous, bulk or interrupt. It also serves to enable the endpoint and configure it for double buffering. Automatic generation of an empty packet for a zero length TX buffer can be disabled via bit NOEMPKT. The register contains 2 bytes and the bit allocation is shown in

Table 24.

Table 24: Endpoint Type register: bit allocation

Bit	15	14	13	12	11	10	9	8
Symbol	reserved							
Reset	-	-	-	-	-	-	-	-
Bus reset	-	-	-	-	-	-	-	-
Access	R/W							
Bit	7	6	5	4	3	2	1	0
Symbol	reserved			NOEMPKT	ENABLE	DBLBUF	ENDPTYP[1:0]	
Reset	-	-	-	0	0	0	00H	
Bus reset	-	-	-	0	0	0	00H	
Access	R/W	R/W	R/W	R/W	R/W	R/W	R/W	

Table 25: Endpoint Type register: bit description

Bit	Symbol	Description
15 to 5	reserved	reserved.
4	NOEMPKT	No Empty Packet: A logic 0 causes an empty packet to be appended to the next IN token of the USB data, if the Buffer Length register or the Endpoint MaxPacketSize register is zero. A logic 1 disables this function. This bit is applicable only in DMA mode.
3	ENABLE	Endpoint Enable: A logic 1 enables the FIFO of the indexed endpoint. The memory size is allocated as specified in the Endpoint MaxPacketSize register. A logic 0 disables the FIFO. Note: 'Stalling' a data endpoint will confuse the Data Toggle bit on the stalled endpoint because the internal logic picks up from where it has stalled. Therefore, the Data Toggle bit must be reset by disabling and re-enabling the corresponding endpoint (by setting the bit 'ENABLE' to 0 or 1 in the endpoint type register) to reset the PID.
2	DBLBUF	Double Buffering: A logic 1 enables double buffering for the indexed endpoint. A logic 0 disables double buffering.
1 to 0	ENDPTYP[1:0]	Endpoint Type: These bits select the endpoint type as follows: 01H — isochronous 02H — bulk 03H — interrupt.

9.3.7 Short Packet register (address: 24H)

This register is reserved.

9.4 DMA registers

Two types of Generic DMA transfer and three types of IDE-specified transfer can be done by writing the proper opcode in the DMA Command Register. The control bits are given in [Table 26](#) (Generic DMA transfers) and [Table 27](#) (IDE-specified transfers).

GDMA read/write (opcode = 00H/01H) — Generic DMA Slave mode; Depending on the MODE[1:0] bit set in the DMA configuration register, either the DACK signal or the DIOR/DIOW signals are used to strobe the data. These signals are driven by the external DMA Controller.

GDMA slave mode can operate in either counter mode or EOT only mode.

In counter mode, the DIS_XFER_CNT bit in the DMA configuration register must be set to logic 0. The DMA transfer counter register must be programmed before any DMA command is issued. The DMA transfer counter is set by writing from the LSByte to the MSByte (address: 34H to 37H). The DMA transfer count is updated internally only after the MSByte has been written. Once the DMA transfer is started, the transfer counter starts decrementing and upon reaching '0', the DMA_XFER_OK bit is set and an interrupt is generated by the ISP1581. If the DMA master wants to terminate the DMA transfer, it can issue an EOT signal to the ISP1581. This EOT signal overrides the transfer counter and can terminate the DMA transfer at any time.

In the EOT only mode, DIS_XFER_CNT has to be set to logic 1. Although the DMA transfer counter can still be programmed, it will not have any effect on the DMA transfer. DMA transfer will start once the DMA command is issued. Any of the following three ways will terminate this DMA transfer:

- Detecting an external EOT
- Detecting an internal EOT (short packet on an OUT token)
- Resetting the DMA.

There are basically 3 interrupts programmable to differentiate the method of DMA termination; namely, the INT_EOT, EXT_EOT and the DMA_XFER_OK bits in the DMA Interrupt Reason register. Refer to [Table 53](#) for details.

MDMA (Master) read/write (opcode = 06H/07H) — Generic DMA Master mode; Depending on the MODE[1:0] bit set in the DMA configuration register, either the DACK signal or the DIOR/DIOW signals are used to strobe the data. these signals are driven by the ISP1581.

In the Master mode, BURST[2:0],DIS_XFER_CNT in the DMA configuration register and the external EOT signal are not applicable. DMA transfer counter is always enabled and the DMA_XFER_OK bit is set to '1' once the counter reaches '0'.

PIO read/write (opcode = 04H/05H) — PIO mode for IDE transfers; the specification of this mode can be obtained from the *ATA Specification Rev. 4*. DIOR and DIOW are used as data strobes, IORDY can be used by the device to extend the PIO cycle.

MDMA read/write (opcode = 06H/07H) — Multi word DMA mode for IDE transfers; the specification of this mode can be obtained from the *ATA Specification Rev. 4*. DIOR and DIOW are used as data strobes, while DREQ and DACK serve as handshake signals.

UDMA read/write (opcode = 02H/03H) — Ultra DMA mode for IDE transfers; the specification of this mode can be obtained from the *ATA Specification Rev. 4*. Pins DA0 to DA2, CS0 and CS1 are used to select a device register for access. Control signals are mapped as follows: DREQ (= DMARQ), DACK (= DMACK), DIOW (= STOP), DIOR (= HDMARDY or HSTROBE), IORDY (= DSTROBE or DDMARDY).

Table 26: Control bits for Generic DMA transfers

Control bits	Description
GDMA read/write (opcode = 00H/01H)	
DMA Configuration register (see Table 33 and Table 34)	
BURST[2:0]	determines the number of DMA cycles, during which pin DREQ is kept asserted
MODE[1:0]	determines the active read/write data strobe signals
WIDTH0	selects the DMA bus width: 8 or 16 bits
DIS_XFER_CNT	disables the use of the DMA Transfer Counter
ATA_MODE	set to logic 0 (non-ATA transfer)
DMA Hardware register (see Table 35 and Table 36)	
EOT_POL	selects the polarity of the EOT signal
ENDIAN[1:0]	determines whether the data is to be byte swapped or normal. Applicable only in 16 bit mode.
ACK_POL, DREQ_POL, WRITE_POL, READ_POL	select the polarity of the DMA handshake signals
MASTER	set to logic 0 (slave)
MDMA (Master) read/write (opcode = 06H/07H)	
DMA Configuration register (see Table 33 and Table 34)	
DMA_MODE[1:0]	determines the MDMA timings for the DIOR and DIOW strobes (value 03H is used for UDMA only)
MODE[1:0]	determines the active data strobe(s).
WIDTH	selects the DMA bus width: 8 or 16 bits
DIS_XFER_CNT	disables the use of the DMA Transfer Counter
ATA_MODE	set to logic 1 (ATA transfer)
DMA Hardware register (see Table 35 and Table 36)	
EOT_POL	input EOT is not used
ENDIAN[1:0]	determines whether the data is to be byte swapped or normal. Applicable only in 16 bit mode.
ACK_POL, DREQ_POL, WRITE_POL, READ_POL	select the polarity of the DMA handshake signals
MASTER	set to logic 1 (master)

Table 27: Control bits for IDE-specified DMA transfers

Control bits	Description
PIO read/write (opcode = 04H/05H)	
DMA Configuration register (see Table 33 and Table 34)	
PIO_MODE[2:0]	selects the PIO mode; timings are ATA(PI) compatible
ATA_MODE	set to logic 1 (ATA transfer)

Table 27: Control bits for IDE-specified DMA transfers...continued

Control bits	Description
DMA Hardware register (see Table 35 and Table 36)	
MASTER	set to logic 0
MDMA read/write (opcode = 06H/07H)	
DMA Configuration register (see Table 33 and Table 34)	
DMA_MODE[1:0]	selects the MDMA mode; timings are ATA(PI) compatible
ATA_MODE	set to logic 1 (ATA transfer)
DMA Hardware register (see Table 35 and Table 36)	
MASTER	set to logic 0
UDMA read/write (opcode = 02H/03H)	
DMA Configuration register (see Table 33 and Table 34)	
DMA_MODE[1:0]	selects the UDMA mode; timings are ATA(PI) compatible
IGNORE_IORDY	used to ignore the IORDY pin during transfer
ATA_MODE	set to logic 1 (ATA transfer)
DMA Hardware register (see Table 35 and Table 36)	
MASTER	set to logic 0

Remark: The DMA bus defaults to three-state, until a DMA command is executed. All the other control signals are not three-stated.

9.4.1 DMA Command register (address: 30H)

The DMA Command register is a 1-byte register that initiates all DMA transfer activity on the DMA Controller. The register is write-only: reading it will return FFH.

Remark: The DMA bus will be in three-state until a DMA command is executed.

Table 28: DMA Command register: bit allocation

Bit	7	6	5	4	3	2	1	0
Symbol	DMA_CMD[7:0]							
Reset	FFH							
Bus reset	FFH							
Access	W							

Table 29: DMA Command register: bit description

Bit	Symbol	Description
7:0	DMA_CMD[7:0]	DMA command code, see Table 30.

Table 30: DMA commands

Code (Hex)	Name	Description
00	GDMA Read	Generic DMA IN token transfer (slave mode only): Data is transferred from the external DMA bus to the internal buffer. Strobe: DIOW by external DMA Controller.
01	GDMA Write	Generic DMA OUT token transfer (slave mode only): Data is transferred from the internal buffer to the external DMA bus. Strobe: DIOR by external DMA Controller.
02	UDMA Read	UDMA Read command: Data is transferred from the external DMA to the internal DMA bus.
03	UDMA Write	UDMA Write command: Data is transferred in UDMA mode from the internal buffer to the external DMA bus.
04	PIO Read ^[1]	PIO Read command for ATAPI device: Data is transferred in PIO mode from the external DMA bus to the internal buffer. Data transfer starts when IORDY is asserted. Inputs DREQ and DACK are ignored.
05	PIO Write ^[1]	PIO Write command for ATAPI device: Data is transferred in PIO mode from the internal buffer to the external DMA bus. Data transfer starts when IORDY is asserted. Inputs DREQ and DACK are ignored.
06	MDMA Read	Multiword DMA Read: Data is transferred from the external DMA bus to the internal buffer.
07	MDMA Write	Multiword DMA Write: Data is transferred from the internal buffer to the external DMA bus.
0A	Read 1F0	Read at address 01F0H: Initiates a PIO Read cycle from Task File 1F0. Before issuing this command the task file byte count should be programmed at address 1F4H (LSB) and 1F5H (MSB).
0B	Poll BSY	Poll BSY status bit for ATAPI device: Starts repeated PIO Read commands to poll the BSY status bit of the ATAPI device. When BSY = 0, polling is terminated and an interrupt is generated.
0C	Read Task Files	Read Task Files: Reads all task file registers except 1F0H and 1F7H. When reading has been completed, an interrupt is generated.
0D	-	reserved
0E	Validate Buffer	Validate Buffer (for debugging only): Request from the microcontroller to validate the endpoint buffer following an ATA to USB data transfer.
0F	Clear Buffer	Clear Buffer: Request from the microcontroller to clear the endpoint buffer after a USB to ATA data transfer.
10	Restart	Restart: Request from the microcontroller to move the buffer pointers to the beginning of the endpoint FIFO.

Table 30: DMA commands...continued

Code (Hex)	Name	Description
11	Reset DMA	Reset DMA: Initializes the DMA core to its power-on reset state. Remark: When the DMA core is reset during the Reset DMA command, the DREQ, DACK, DIOW and DIOR handshake pins will be temporarily asserted. This can cause some confusion to the external DMA Controller. To prevent this from happening, start the external DMA Controller only after the DMA reset is done.
12	MDMA stop	MDMA stop: This command immediately stops the MDMA data transfer. This is applicable for commands 06H and 07H only.
13 to FF	-	reserved

[1] PIO Read or Write that started using DMA Command Register only performs 16-bit transfer.

9.4.2 DMA Transfer Counter register (address: 34H)

This 4-byte register is used to set up the total byte count of a DMA transfer (DMACR). It indicates the remaining number of bytes left for transfer. The bit allocation is given in [Table 31](#).

The transfer counter is used in DMA modes: PIO (commands: 04H, 05H), UDMA (commands: 02H, 03H), MDMA (commands: 06H, 07H) and GDMA (commands: 00H, 01H).

A new value is written into the register starting with the lower byte (DMACR1) or the lower word (MSByte: DMACR2, LSByte: DMACR1). Internally, the transfer counter is initialized only after the last byte (DMACR4) has been written.

In the GDMA Slave mode only, the transfer counter can be disabled via bit DIS_XFER_CNT in the DMA Configuration Register (see [Table 33](#)). In this case, input signal EOT can be used to terminate the DMA transfer when data is transferred from the external device to the host via IN tokens. The last packet in the FIFO is validated when pin EOT is asserted.

Table 31: DMA Transfer Counter register: bit allocation

Bit	31	30	29	28	27	26	25	24
Symbol	DMACR4 = DMACR[31:24]							
Reset	00H							
Bus reset	00H							
Access	R/W							
Bit	23	22	21	20	19	18	17	16
Symbol	DMACR3 = DMACR[23:16]							
Reset	00H							
Bus reset	00H							
Access	R/W							

Bit	15	14	13	12	11	10	9	8
Symbol	DMACR2 = DMACR[15:8]							
Reset	00H							
Bus reset	00H							
Access	R/W							
Bit	7	6	5	4	3	2	1	0
Symbol	DMACR1 = DMACR[7:0]							
Reset	00H							
Bus reset	00H							
Access	R/W							

Table 32: DMA Transfer Counter register: bit description

Bit	Symbol	Description
31 to 24	DMACR4, DMACR[31:24]	DMA transfer counter byte 4 (MSB)
23 to 16	DMACR3, DMACR[23:16]	DMA transfer counter byte 3
15 to 8	DMACR2, DMACR[15:8]	DMA transfer counter byte 2
7 to 0	DMACR1, DMACR[7:0]	DMA transfer counter byte 1 (LSB)

9.4.3 DMA Configuration register (address: 38H)

This register defines the DMA configuration for the Generic DMA (GDMA) and the Ultra-DMA (UDMA) modes. The DMA Configuration register consists of 2 bytes. The bit allocation is given in Table 33.

Table 33: DMA Configuration register: bit allocation

Bit	15	14	13	12	11	10	9	8
Symbol	reserved	IGNORE_ IORDY	ATA_ MODE	DMA_MODE[1:0]		PIO_MODE[2:0]		
Reset	-	0	0	00H		00H		
Bus Reset	-	0	0	00H		00H		
Access	R/W	R/W	R/W	R/W		R/W		
Bit	7	6	5	4	3	2	1	0
Symbol	DIS_ XFER_ CNT	BURST[2:0]		MODE[1:0]		reserved	WIDTH	
Reset	0	00H		00H		-	1	
Bus Reset	0	00H		00H		-	1	
Access	R/W	R/W		R/W		R/W	R/W	

Table 34: DMA Configuration register: bit description

Bit ^[1]	Symbol	Description
15	-	reserved
14	IGNORE_IORDY	A logic 1 ignores the IORDY input signal (UDMA mode only).
13	ATA_MODE	A logic 1 configures the DMA core for ATA or MDMA mode. Used when issuing DMA commands 02H to 07H, 0AH and 0CH; also used when directly accessing task file registers. A logic 0 configures the DMA core for non-ATA mode. Used when issuing DMA commands 00H and 01H.
12 to 11	DMA_MODE[1:0]	These bits affect the timing for UDMA and MDMA mode: 00H — UDMA/MDMA mode 0: ATA(PI) compatible timings 01H — UDMA/MDMA mode 1: ATA(PI) compatible timings 02H — UDMA/MDMA mode 2: ATA(PI) compatible timings 03H — MDMA mode 3: enables the DMA Strobe Timing register (see Table 37 and Table 38) for non-standard strobe durations; only used in MDMA mode.
10 to 8	PIO_MODE[2:0] ^[4]	These bits affect the PIO timing (see Table 77): 00H to 04H — PIO mode 0 to 4: ATA(PI) compatible timings 05H to 07H — reserved.
7	DIS_XFER_CNT	A logic 1 disables the DMA Transfer Counter (see Table 31). The transfer counter can only be disabled in GDMA slave mode; in master mode the counter is always enabled.
6 to 4	BURST[2:0]	These bits select the DMA burst length and the DREQ timing (GDMA Slave mode only): 00H — DREQ is asserted until the last byte/word is transferred or until the FIFO becomes full or empty 01H — DREQ is asserted and negated for each byte/word transferred ^{[2][3]} 02H — DREQ is asserted and negated for every 2 bytes/words transferred ^{[2][3]} 03H — DREQ is asserted and negated for every 4 bytes/words transferred ^{[2][3]} 04H — DREQ is asserted and negated for every 8 bytes/words transferred ^{[2][3]} 05H — DREQ is asserted and negated for every 12 bytes/words transferred ^{[2][3]} 06H — DREQ is asserted and negated for every 16 bytes/words transferred ^{[2][3]} 07H — DREQ is asserted and negated for every 32 bytes/words transferred ^{[2][3]} .

Table 34: DMA Configuration register: bit description...continued

Bit ^[1]	Symbol	Description
3 to 2	MODE[1:0]	<p>These bits only affect the GDMA (slave) and MDMA (master) handshake signals:</p> <p>00H — DIOR (master) or DIOW (slave): strobcs data from the DMA bus into the ISP1581; DIOW (master) or DIOR (slave): puts data from the ISP1581 on the DMA bus</p> <p>01H — DIOR (master) or DACK (slave) strobcs the data from the DMA bus into the ISP1581; DACK (master) or DIOR (slave) puts the data from the ISP1581 on the DMA bus</p> <p>02H — DACK (master and slave) strobcs the data from the DMA bus into the ISP1581 and also puts the data from the ISP1581 on the DMA bus (This mode is applicable only to 16-bit DMA; this mode cannot be used for 8-bit DMA.)</p> <p>03H — reserved.</p>
1	-	reserved
0	WIDTH	<p>This bit selects the DMA bus width for GDMA (slave) and MDMA (master):</p> <p>0 — 8-bit data bus</p> <p>1 — 16-bit data bus.</p>

[1] The DREQ pin will be driven only after you perform a write access to the DMA Configuration register. That is, after you have configured the DMA Configuration register.

[2] DREQ is asserted only if space (writing) or data (reading) is available in the FIFO.

[3] This process is stopped when the transfer FIFO becomes empty.

[4] PIO Read or Write that started using DMA Command Register only performs 16-bit transfer.

9.4.4 DMA Hardware register (address: 3CH)

The DMA Hardware register consists of 1 byte. The bit allocation is shown in [Table 35](#).

This register determines the polarity of the bus control signals (EOT, DACK, DREQ, DIOR, DIOW) and the DMA mode (master or slave). It also controls whether the upper and lower parts of the data bus are swapped (bits ENDIAN[1:0]), for modes GDMA (slave) and MDMA (master) only.

Table 35: DMA Hardware register: bit allocation

Bit	7	6	5	4	3	2	1	0
Symbol	ENDIAN[1:0]		EOT_ POL	MASTER	ACK_ POL	DREQ_ POL	WRITE_ POL	READ_ POL
Reset	00H		0	0	0	1	0	0
Bus reset	00H		0	0	0	1	0	0
Access	R/W		R/W	R/W	R/W	R/W	R/W	R/W

Table 36: DMA Hardware register: bit description

Bit	Symbol	Description
7 to 6	ENDIAN[1:0]	<p>These bits determine whether the data bus is swapped between internal RAM and the DMA bus: This only applies for modes GDMA (slave) and MDMA (master):</p> <p>00H — normal data representation 16-bit bus: MSB on DATA[15:8], LSB on DATA[7:0]</p> <p>01H — swapped data representation 16-bit bus: MSB on DATA[7:0], LSB on DATA[15:8]</p> <p>02H, 03H — reserved.</p> <p>Note: while operating with 8 bit data bus, ENDIAN bits should be always set to 00H.</p>
5	EOT_POL	<p>Selects the polarity of the End Of Transfer input (used in GDMA slave mode only):</p> <p>0 — EOT is active LOW 1 — EOT is active HIGH.</p>
4	MASTER	<p>Selects the DMA master/slave mode:</p> <p>0 — GDMA slave mode. 1 — MDMA master mode.</p>
3	ACK_POL	<p>Selects the DMA acknowledgement polarity:</p> <p>0 — DACK is active LOW 1 — DACK is active HIGH.</p>
2	DREQ_POL	<p>Selects the DMA request polarity:</p> <p>0 — DREQ is active LOW 1 — DREQ is active HIGH.</p>
1	WRITE_POL	<p>Selects the DIOW strobe polarity:</p> <p>0 — DIOW is active LOW 1 — DIOW is active HIGH.</p>
0	READ_POL	<p>Selects the DIOR strobe polarity:</p> <p>0 — DIOR is active LOW 1 — DIOR is active HIGH.</p>

9.4.5 DMA Strobe Timing register (address: 60H)

This 1-byte register controls the strobe timings for the MDMA mode, when the DMA_MODE bits in the DMA Configuration register have been set to 03H. The bit allocation is given in [Table 37](#).

Table 37: DMA Strobe Timing register: bit allocation

Bit	7	6	5	4	3	2	1	0
Symbol		reserved			DMA_STROBE_CNT[4:0]			
Reset	-	-	-			1FH		
Bus reset	-	-	-			1FH		
Access	R/W	R/W	R/W			R/W		

Table 38: DMA Strobe Timing register: bit description

Bit	Symbol	Description
7 to 5	-	reserved.
4 to 0	DMA_STROBE_CNT[4:0]	These bits select the strobe duration for DMA_MODE = 03H (see Table 33). The strobe duration is (N+1) cycles ^[1] , with N representing the value of DMA_STROBE_CNT (see Figure 5).

[1] The cycle duration indicates the internal clock cycle (33.3 ns/cycle).

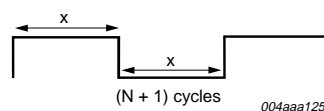

Fig 5. Programmable strobe timing.

9.4.6 Task File registers (addresses: 40H to 4FH)

These registers allow direct access to the internal registers of an ATAPI peripheral using PIO mode. The supported Task File registers and their functions are shown in Table 39. The correct peripheral register is automatically addressed via pins CS1, CS0, DA2, DA1 and DA0 (see Table 40).

Table 39: Task File register functions

Address (Hex)	ATA function	ATAPI function
1F0	data (16-bits)	data (16-bits)
1F1	error/feature	error/feature
1F2	sector count	interrupt reason
1F3	sector number/LBA[7:0]	reserved
1F4	cylinder low/LBA[15:8]	cylinder low
1F5	cylinder high/LBA[23:16]	cylinder high
1F6	drive/head/LBA[27:24]	drive select
1F7	command	status/command
3F6	alternate status/command	alternate status/command
3F7	drive address	reserved

Table 40: ATAPI peripheral register addressing

Task file	CS1	CS0	DA2	DA1	DA0
1F0	H	L	L	L	L
1F1	H	L	L	L	H
1F2	H	L	L	H	L
1F3	H	L	L	H	H
1F4	H	L	H	L	L
1F5	H	L	H	L	H
1F6	H	L	H	H	L
1F7	H	L	H	H	H
3F6	L	H	H	H	L
3F7	L	H	H	H	H

In 8-bit bus mode, the 16-bit Task File register 1F0 requires 2 consecutive write/read accesses before the proper PIO write/read is generated on the IDE interface. The first byte is always the lower byte (LSByte). Other task file registers can be accessed directly.

Writing to Task File registers can be done in any order except for Task File register 1F7, which must be written last.

Table 41: Task File register 1F0 (address: 40H): bit allocation

$CS1 = H, CS0 = L, DA2 = L, DA1 = L, DA0 = L.$

Bit	7	6	5	4	3	2	1	0
Symbol	data (ATA or ATAPI)							
Reset	00H							
Bus reset	00H							
Access	R/W							

Table 42: Task File register 1F1 (address: 48H): bit allocation

$CS1 = H, CS0 = L, DA2 = L, DA1 = L, DA0 = H.$

Bit	7	6	5	4	3	2	1	0
Symbol	error/feature (ATA or ATAPI)							
Reset	00H							
Bus reset	00H							
Access	R/W							

Table 43: Task File register 1F2 (address: 49H): bit allocation

$CS1 = H, CS0 = L, DA2 = L, DA1 = H, DA0 = L.$

Bit	7	6	5	4	3	2	1	0
Symbol	sector count (ATA) or interrupt reason (ATAPI)							
Reset	00H							
Bus reset	00H							
Access	R/W							

Table 44: Task File register 1F3 (address: 4AH): bit allocation*CS1 = H, CS0 = L, DA2 = L, DA1 = H, DA0 = H.*

Bit	7	6	5	4	3	2	1	0
Symbol	sector number/LBA[7:0] (ATA), reserved (ATAPI)							
Reset	00H							
Bus reset	00H							
Access	R/W							

Table 45: Task File register 1F4 (address: 4BH): bit allocation*CS1 = H, CS0 = L, DA2 = H, DA1 = L, DA0 = L.*

Bit	7	6	5	4	3	2	1	0
Symbol	cylinder low/LBA[15:8] (ATA) or cylinder low (ATAPI)							
Reset	00H							
Bus reset	00H							
Access	R/W							

Table 46: Task File register 1F5 (address: 4CH): bit allocation*CS1 = H, CS0 = L, DA2 = H, DA1 = L, DA0 = H.*

Bit	7	6	5	4	3	2	1	0
Symbol	cylinder high/LBA[23:16] (ATA) or cylinder high (ATAPI)							
Reset	00H							
Bus reset	00H							
Access	R/W							

Table 47: Task File register 1F6 (address: 4DH): bit allocation*CS1 = H, CS0 = L, DA2 = H, DA1 = H, DA0 = L.*

Bit	7	6	5	4	3	2	1	0
Symbol	drive/head/LBA[27:24] (ATA) or drive (ATAPI)							
Reset	00H							
Bus reset	00H							
Access	R/W							

Table 48: Task File register 1F7 (address: 44H): bit allocation*CS1 = H, CS0 = L, DA2 = H, DA1 = H, DA0 = H.*

Bit	7	6	5	4	3	2	1	0
Symbol	command (ATA) or status ^[1] /command (ATAPI)							
Reset	00H							
Bus reset	00H							
Access	W							

[1] Task File register 1F7 is a write-only register; a read will return FFH.

Table 49: Task File register 3F6 (address: 4EH): bit allocation

CS1 = L, CS0 = H, DA2 = H, DA1 = H, DA0 = L.

Bit	7	6	5	4	3	2	1	0
Symbol	alternate status/command (ATA or ATAPI)							
Reset	00H							
Bus reset	00H							
Access	R/W							

Table 50: Task File register 3F7 (address: 4FH): bit allocation

CS1 = L, CS0 = H, DA2 = H, DA1 = H, DA0 = H.

Bit	7	6	5	4	3	2	1	0
Symbol	drive address (ATA) or reserved (ATAPI)							
Reset	00H							
Bus reset	00H							
Access	R/W							

9.4.7 DMA Interrupt Reason register (address: 50H)

This 2-byte register shows the source(s) of a DMA interrupt. Each bit is refreshed after a DMA command has been executed. An interrupt source is cleared by writing a logic 1 to the corresponding bit. The bit allocation is given in [Table 51](#).

Table 51: DMA Interrupt Reason register: bit allocation

Bit	15	14	13	12	11	10	9	8
Symbol	reserved			ODD_IND	EXT_EOT	INT_EOT	INTRQ_PENDING	DMA_XFER_OK
Reset	-	-	-	0	0	0	0	0
Bus reset	-	-	-	0	0	0	0	0
Access	R/W	R/W	R/W	R/W	R/W	R/W	R/W	R/W
Bit	7	6	5	4	3	2	1	0
Symbol	1F0_WF_E	1F0_WF_F	1F0_RF_E	READ_1F0	BSY_DONE	TF_RD_DONE	CMD_INTRQ_OK	reserved
Reset	0	0	0	0	0	0	0	-
Bus reset	0	0	0	0	0	0	0	-
Access	R/W	R/W	R/W	R/W	R/W	R/W	R/W	R/W

Table 52: DMA Interrupt Reason Register: bit description

Bit	Symbol	Description
15 to 13	-	reserved
12	ODD_IND	A logic 1 indicates that the last packet with odd bytes has been transferred from the OUT token buffer to the DMA. This is applicable only for the OUT token data in the DMA slave mode. It has no meaning for the IN token data. Refer to the document <i>Using the Odd Bit Indicator for DMA</i> .
11	EXT_EOT	A logic 1 indicates that an external EOT is detected. This is applicable only in GDMA slave mode.
10	INT_EOT	A logic 1 indicates that an internal EOT is detected. see Table 53 .

Table 52: DMA Interrupt Reason Register: bit description...continued

Bit	Symbol	Description
9	INTRQ_PENDING	A logic 1 indicates that a pending interrupt was detected on pin INTRQ.
8	DMA_XFER_OK	A logic 1 indicates that the DMA transfer has been completed (DMA Transfer Counter has become zero). This bit is only used in GDMA (slave) mode and MDMA (master) mode.
7	1F0_WF_E	A logic 1 indicates that the 1F0 write FIFO is empty and the microcontroller can start writing data.
6	1F0_WF_F	A logic 1 indicates that the 1F0 write FIFO is full and the microcontroller must stop writing data.
5	1F0_RF_E	A logic 1 indicates that 1F0 read FIFO is empty and the microcontroller must stop reading data.
4	READ_1F0	A logic 1 indicates that 1F0 FIFO contains unread data and the microcontroller can start reading data.
3	BSY_DONE	A logic 1 indicates that the BSY status bit has become zero and polling has been stopped.
2	TF_RD_DONE	A logic 1 indicates that the Read Task Files command has been completed.
1	CMD_INTRQ_OK	A logic 1 indicates that all bytes from the FIFO have been transferred (DMA Transfer Count zero) and an interrupt on pin INTRQ was detected.
0	-	reserved

Table 53: Internal EOT-Functional relation with DMA_XFER_OK bit

INT_EOT	DMA_XFER_OK	Description
1	0	During the DMA transfer, there is a premature termination with short packet ^[1] .
1	1	DMA transfer is completed with short packet and the DMA transfer counter has reached '0'.
0	1	DMA transfer is completed without any short packet and the DMA transfer counter has reached '0'.

[1] The short packet does not include zero-length packets.

9.4.8 DMA Interrupt Enable register (address: 54H)

This 2-byte register controls the interrupt generation of the source bits in the DMA Interrupt Reason register (see Table 51). The bit allocation is given in Table 54. The bit descriptions are given in Table 52. A logic 1 enables interrupt generation. The values after a (bus) reset are logic 0 (disabled).

Table 54: DMA Interrupt Enable register: bit allocation

Bit	15	14	13	12	11	10	9	8
Symbol	reserved			IE_ODD_IND	IE_EXT_EOT	IE_INT_EOT	IE_INTRQ_PENDING	IE_DMA_XFER_OK
Reset	-	-	-	0	0	0	0	0
Bus reset	-	-	-	0	0	0	0	0
Access	R/W	R/W	R/W	R/W	R/W	R/W	R/W	R/W

Bit	7	6	5	4	3	2	1	0
Symbol	IE_1F0_WF_E	IE_1F0_WF_F	IE_1F0_RF_E	IE_READ_1F0	IE_BSY_DONE	IE_TF_RD_DONE	IE_CMD_INTRQ_OK	reserved
Reset	0	0	0	0	0	0	0	-
Bus reset	0	0	0	0	0	0	0	-
Access	R/W	R/W	R/W	R/W	R/W	R/W	R/W	R/W

9.4.9 DMA Endpoint register (address: 58H)

This 1-byte register selects a USB endpoint FIFO as a source or destination for DMA transfers. The bit allocation is given in [Table 55](#).

Table 55: DMA Endpoint register: bit allocation

Bit	7	6	5	4	3	2	1	0
Symbol	reserved				EPIDX[2:0]			DMADIR
Power Reset	-	-	-	-	0	0	0	0
Bus Reset	-	-	-	-	0	0	0	0
Access	R/W	R/W	R/W	R/W	R/W	R/W	R/W	R/W

Table 56: DMA Endpoint register: bit description

Bit	Symbol	Description
7 to 4	-	reserved
3 to 1	EPIDX[2:0]	selects the indicated endpoint for DMA access
0	DMADIR	<p>0 — selects the RX/OUT FIFO for DMA read transfers</p> <p>1 — selects the TX/IN FIFO for DMA write transfers.</p>

The DMA Endpoint register must not reference the endpoint that is indexed by the Endpoint Index register (02CH) at any time. Doing so would result in data corruption. Therefore, if the DMA Endpoint register is unused, point it to an unused endpoint. However, if the DMA Endpoint register is pointed to an active endpoint, the firmware must not reference the same endpoint on the Endpoint Index register.

9.5 General registers

9.5.1 Interrupt register (address: 18H)

The Interrupt register consists of 4 bytes. The bit allocation is given in [Table 57](#).

When a bit is set in the Interrupt register, this indicates that the hardware condition for an interrupt has occurred. When the Interrupt register content is non-zero, the INT output will be asserted. Upon detecting the interrupt, the external microprocessor must read the Interrupt register to determine the source of the interrupt.

Each endpoint buffer has a dedicated interrupt bit (EPnTX, EPnRX). In addition, various bus states can generate an interrupt: Resume, Suspend, Pseudo-SOF, SOF and Bus Reset. The DMA Controller only has one interrupt bit: the source for a DMA interrupt is shown in the DMA Interrupt Reason register (see [Table 51](#)).

Each interrupt bit can be individually cleared by writing a logic 1. The DMA interrupt bit can be cleared by writing a logic 1 to the related interrupt source bit in the DMA Interrupt Reason register and writing a logic 1 to the DMA bit of the interrupt register.

Table 57: Interrupt register: bit allocation

Bit	31	30	29	28	27	26	25	24
Symbol	reserved						EP7TX	EP7RX
Reset	-	-	-	-	-	-	0	0
Bus reset	-	-	-	-	-	-	0	0
Access	R/W	R/W	R/W	R/W	R/W	R/W	R/W	R/W
Bit	23	22	21	20	19	18	17	16
Symbol	EP6TX	EP6RX	EP5TX	EP5RX	EP4TX	EP4RX	EP3TX	EP3RX
Reset	0	0	0	0	0	0	0	0
Bus reset	0	0	0	0	0	0	0	0
Access	R/W	R/W	R/W	R/W	R/W	R/W	R/W	R/W
Bit	15	14	13	12	11	10	9	8
Symbol	EP2TX	EP2RX	EP1TX	EP1RX	EP0TX	EP0RX	reserved	EPOSETUP
Reset	0	0	0	0	0	0	-	0
Bus reset	0	0	0	0	0	0	-	0
Access	R/W	R/W	R/W	R/W	R/W	R/W	R/W	R/W
Bit	7	6	5	4	3	2	1	0
Symbol	reserved	DMA	HS_STAT	RESUME	SUSP	PSOF	SOF	BRESET
Reset	-	0	0	0	0	0	0	0
Bus reset	-	0	0	0	0	0	0	unchanged
Access	R/W	R/W	R/W	R/W	R/W	R/W	R/W	R/W

Table 58: Interrupt register: bit description

Bit	Symbol	Description
31 to 26	reserved	reserved; must write logic 0
25	EP7TX	A logic 1 indicates the Endpoint 7 TX buffer as interrupt source.
24	EP7RX	A logic 1 indicates the Endpoint 7 RX buffer as interrupt source.
23	EP6TX	A logic 1 indicates the Endpoint 6 TX buffer as interrupt source.
22	EP6RX	A logic 1 indicates the Endpoint 6 RX buffer as interrupt source.
21	EP5TX	A logic 1 indicates the Endpoint 5 TX buffer as interrupt source.
20	EP5RX	A logic 1 indicates the Endpoint 5 RX buffer as interrupt source.
19	EP4TX	A logic 1 indicates the Endpoint 4 TX buffer as interrupt source.
18	EP4RX	A logic 1 indicates the Endpoint 4 RX buffer as interrupt source.
17	EP3TX	A logic 1 indicates the Endpoint 3 TX buffer as interrupt source.
16	EP3RX	A logic 1 indicates the Endpoint 3 RX buffer as interrupt source.
15	EP2TX	A logic 1 indicates the Endpoint 2 TX buffer as interrupt source.
14	EP2RX	A logic 1 indicates the Endpoint 2 RX buffer as interrupt source.
13	EP1TX	A logic 1 indicates the Endpoint 1 TX buffer as interrupt source.
12	EP1RX	A logic 1 indicates the Endpoint 1 RX buffer as interrupt source.
11	EP0TX	A logic 1 indicates the Endpoint 0 data TX buffer as interrupt source.
10	EP0RX	A logic 1 indicates the Endpoint 0 data RX buffer as interrupt source.

Table 58: Interrupt register: bit description...continued

Bit	Symbol	Description
9	reserved	reserved.
8	EPOSETUP	A logic 1 indicates that a SETUP token was received on Endpoint 0.
7	reserved	reserved.
6	DMA	DMA status: A logic 1 indicates a change in the DMA Status register.
5	HS_STAT	High Speed Status: A logic 1 indicates a change from FS to HS mode (HS connection). This bit is not set, when the system goes into a FS suspend.
4	RESUME	Resume status: A logic 1 indicates that a status change from 'suspend' to 'resume' (active) was detected.
3	SUSP	Suspend status: A logic 1 indicates that a status change from active to 'suspend' was detected on the bus.
2	PSOF	Pseudo SOF interrupt: A logic 1 indicates that a Pseudo SOF or μ SOF was received. Pseudo SOF is an internally generated clock signal (FS: 1 ms period, HS: 125 μ s period) synchronized to the USB bus SOF/ μ SOF.
1	SOF	SOF interrupt: A logic 1 indicates that a SOF/ μ SOF was received.
0	BRESET	Bus Reset: A logic 1 indicates that a USB bus reset was detected.

9.5.2 Chip ID register (address: 70H)

This read-only register contains the chip identification and the hardware version numbers. The firmware should check this information to determine the functions and features supported. The register contains 3 bytes and the bit allocation is shown in Table 59.

Table 59: Chip ID register: bit allocation

Bit	23	22	21	20	19	18	17	16
Symbol	CHIPID[23:16]							
Reset	15H							
Bus reset	15H							
Access	R							
Bit	15	14	13	12	11	10	9	8
Symbol	CHIPID[15:8]							
Reset	81H							
Bus reset	81H							
Access	R							
Bit	7	6	5	4	3	2	1	0
Symbol	VERSION[7:0]							
Reset	51H							
Bus reset	51H							
Access	R							

Table 60: Chip ID Register: bit description

Bit	Symbol	Description
23 to 16	CHIPID[23:16]	Chip ID: lower byte (15H)
15 to 8	CHIPID[15:8]	Chip ID: upper byte (81H)
7 to 0	VERSION	Version number (51H): The version number will be upgraded as and when there are new revisions with improved performance and functionality.

9.5.3 Frame Number register (address: 74H)

This read-only register contains the frame number of the last successfully received Start Of Frame (SOF). The register contains 2 bytes and the bit allocation is given in Table 61. In case of 8-bit access the register content is returned lower byte first.

Table 61: Frame Number register: bit allocation

Bit	15	14	13	12	11	10	9	8
Symbol	reserved		MICROSOF[2:0]			SOFR[10:8]		
Power Reset	-	-		00H			00H	
Bus Reset	-	-		00H			00H	
Access	R	R		R			R	
Bit	7	6	5	4	3	2	1	0
Symbol	SOFR[7:0]							
Power Reset				00H				
Bus Reset				00H				
Access				R				

Table 62: Frame Number register: bit description

Bit	Symbol	Description
13 to 11	MICROSOF[2:0]	microframe number
10 to 0	SOFR[10:0]	frame number

9.5.4 Scratch register (address: 78H)

This 16-bit register can be used by the firmware to save and restore information, for example, the device status before it enters 'suspend' state. The bit allocation is given in Table 63.

Table 63: Scratch Register: bit allocation

Bit	15	14	13	12	11	10	9	8
Symbol	SFIRH[7:0]							
Reset				00H				
Bus reset				00H				
Access				R/W				
Bit	7	6	5	4	3	2	1	0
Symbol	SFIRL[7:0]							
Reset				00H				
Bus reset				00H				
Access				R/W				

Table 64: Scratch Information register: bit description

Bit	Symbol	Description
15 to 8	SFIRH[7:0]	scratch firmware information register (high byte)
7 to 0	SFIRL[7:0]	scratch firmware information register (low byte)

9.5.5 Test Mode register (address: 84H)

This 1-byte register allows the firmware to set the (D+, D-) lines to predetermined states for testing purposes. The bit allocation is given in Table 65.

Remark: Only one bit can be set at a time.

Table 65: Test Mode register: bit allocation

Bit	7	6	5	4	3	2	1	0
Symbol	FORCEHS	reserved		FORCEFS	PRBS	KSTATE	JSTATE	SE0_NAK
Reset	0	-	-	0	0	0	0	0
Bus reset	0	-	-	0	0	0	0	0
Access	R/W	R/W	R/W	R/W	R/W	R/W	R/W	R/W

Table 66: Test Mode Register: bit description

Bit	Symbol	Description
7 ^[1]	FORCEHS	A logic 1 forces the hardware to high-speed mode only and disables the chirp detection logic.
6 to 5	-	reserved.
4 ^[1]	FORCEFS	A logic 1 forces the physical layer to full-speed mode only and disables the chirp detection logic.
3 ^[2]	PRBS	A logic 1 sets the (D+, D-) lines to toggle in a pre-determined random pattern.
2 ^[2]	KSTATE	Writing a logic 1 sets the (D+, D-) lines to the K state.
1 ^[2]	JSTATE	Writing a logic 1 sets the (D+, D-) lines to the J state.
0 ^[2]	SE0_NAK	Writing a logic 1 sets the (D+, D-) lines to a HS quiescent state. The device only responds to a valid HS IN token with a NAK.

[1] Either FORCEHS or FORCEFS should be set to logic 1 at a time.

[2] Of the four bits (PRBS, KSTATE, JSTATE and SE0_NAK), only one bit must be set to logic 1 at a time.

10. Power supply

The ISP1581 can be powered from 3.3 V or 5.0 V.

If the ISP1581 is powered from $V_{CC} = 5.0$ V, an integrated voltage regulator provides a 3.3 V supply voltage for the internal logic and the USB transceiver. For connection details, see Figure 6.

The ISP1581 can also be operated from $V_{CC} = 3.3$ V. In this case, the internal regulator is disabled and all the supply pins are connected to V_{CC} . For connection details see Figure 7.

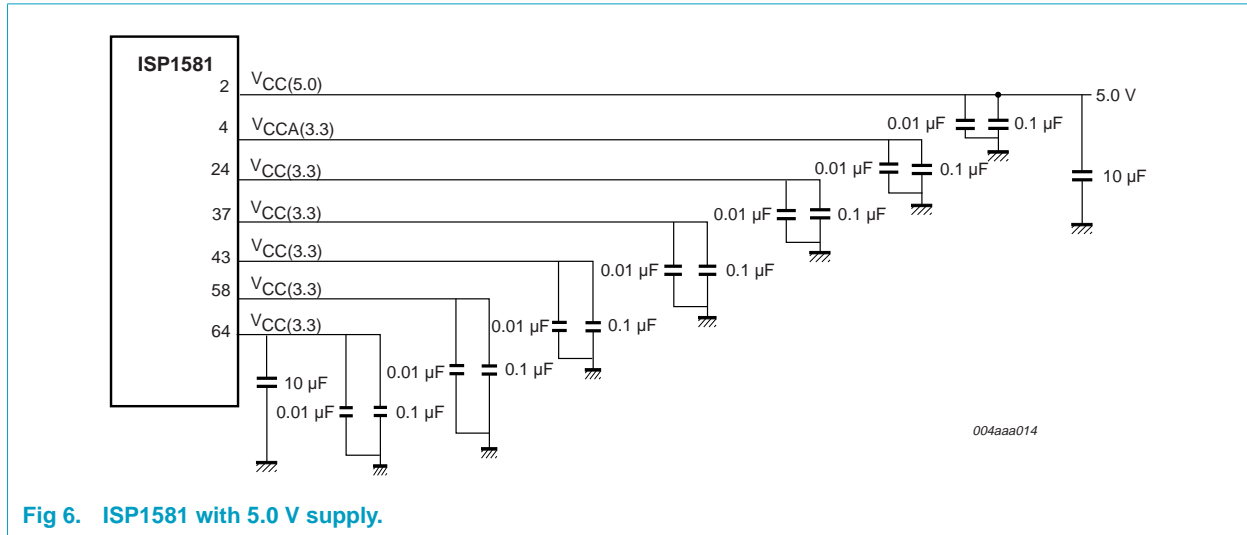

Fig 6. ISP1581 with 5.0 V supply.

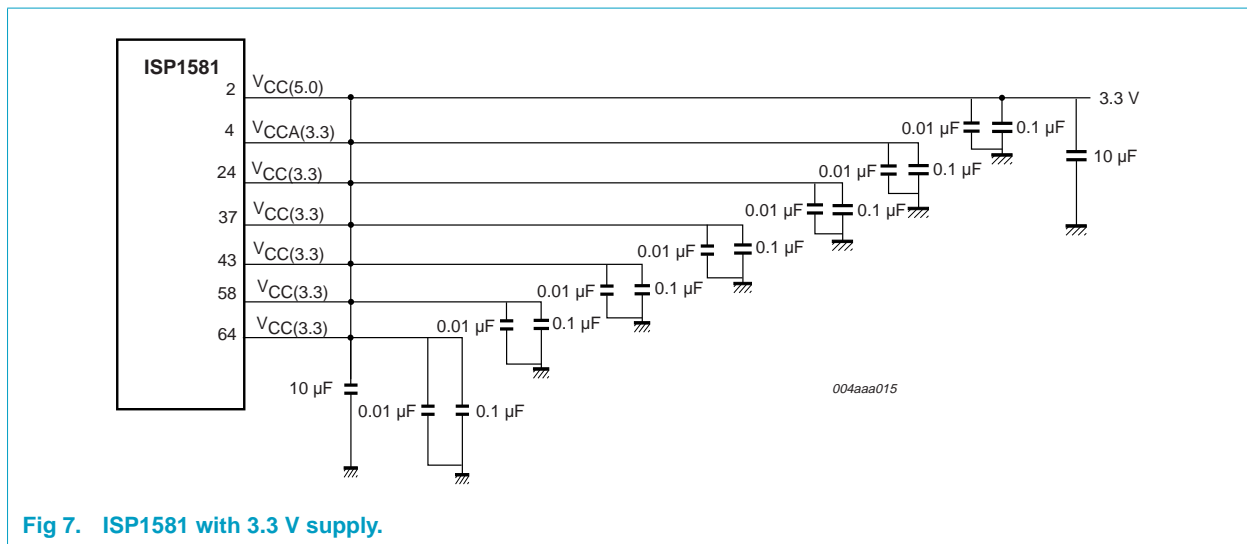

Fig 7. ISP1581 with 3.3 V supply.

11. Limiting values

Table 67: Absolute maximum ratings

In accordance with the Absolute Maximum Rating System (IEC 60134).

Symbol	Parameter	Conditions	Min	Max	Unit
V_{CC}	supply voltage		-0.5	+6.0	V
V_I	input voltage		-0.5	$V_{CC} + 0.5$	V
I_{lu}	latch-up current	$V_I < 0$ or $V_I > V_{CC}$	-	100	mA
V_{esd}	electrostatic discharge voltage	$I_{LI} < 1 \mu A$			
		pins D+, D-, GND and $V_{CC(5.0)}$	-	± 4000	V
		other pins	-	± 2000	V
T_{stg}	storage temperature		-60	+150	°C
P_{tot}	total power dissipation		-	770	mW

12. Recommended operating conditions

Table 68: Recommended operating conditions

Symbol	Parameter	Conditions	Min	Max	Unit
V_{CC}	supply voltage	with voltage converter	4.0	5.5	V
		without voltage converter	3.0	3.6	V
V_I	input voltage range		0	5.5	V
$V_{I(A/I/O)}$	input voltage on analog I/O pins (D+, D-)		0	3.6	V
$V_{O(od)}$	open-drain output pull-up voltage		0	V_{CC}	V
T_{amb}	ambient temperature		-40	+85	°C

13. Static characteristics

Table 69: Static characteristics; supply pins

$V_{CC} = 4.0$ to 5.5 V; $V_{GND} = 0$ V; $T_{amb} = -40$ to $+85$ °C; unless otherwise specified.

Symbol	Parameter	Conditions	Min	Typ	Max	Unit
$V_{CCA(3.3)}$	regulated supply voltage	with voltage converter	3.0 ^[1]	3.3	3.6	V
I_{CC}	operating supply current		-	130	-	mA
$I_{CC(susp)}$	suspend supply current	no pull-up on pin D+	-	450	-	μA

[1] In 'suspend' mode the minimum voltage is 2.7 V.

Table 70: Static characteristics: digital pins $V_{CC} = 4.0$ to 5.5 V; $V_{GND} = 0$ V; $T_{amb} = -40$ to $+85$ °C; unless otherwise specified.

Symbol	Parameter	Conditions	Min	Typ	Max	Unit
Input levels						
V_{IL}	LOW-level input voltage		-	-	0.8	V
V_{IH}	HIGH-level input voltage		2.0	-	-	V
Output levels						
V_{OL}	LOW-level output voltage	$I_{OL} = \text{rated drive}$	-	-	0.4	V
V_{OH}	HIGH-level output voltage	$I_{OH} = \text{rated drive}$	2.6	-	-	V
Leakage current						
I_{LI}	input leakage current		-5 ^[1]	-	+5 ^[1]	µA

[1] This value is applicable to transistor input only. The value will be different if internal pull-up or pull-down resistors are used.

Table 71: Static characteristics: analog I/O pins (D+, D-)^[1] $V_{CC} = 4.0$ to 5.5 V; $V_{GND} = 0$ V; $T_{amb} = -40$ to $+85$ °C; unless otherwise specified.

Symbol	Parameter	Conditions	Min	Typ	Max	Unit
Original USB transceiver (full-speed)						
Input levels (differential receiver)						
V_{DI}	differential input sensitivity	$ V_{I(D+)} - V_{I(D-)} $	0.2	-	-	V
V_{CM}	differential common mode voltage	includes V_{DI} range	0.8	-	2.5	V
Input levels (single-ended receiver)						
V_{IL}	LOW-level input voltage		-	-	0.8	V
V_{IH}	HIGH-level input voltage		2.0	-	-	V
V_{hys}	hysteresis voltage		0.4	-	0.7	V
Output levels						
V_{OL}	LOW-level output voltage	pull-up on D+; $R_L = 1.5$ kΩ to +3.6V	0	-	0.4	V
V_{OH}	HIGH-level output voltage	pull-down on D+, D-; $R_L = 15$ kΩ to GND	2.8	-	3.6	V
Hi-Speed USB transceiver						
Input levels (differential receiver)						
V_{HSSQ}	high-speed squelch detection threshold (differential)	squelch detected	-	-	100	mV
		no squelch detected	150	-	-	mV
V_{HSDSC}	high-speed disconnect detection threshold (differential)	disconnect detected	625	-	-	mV
		disconnect not detected	-	-	525	mV
V_{HSDI}	high-speed differential input sensitivity	$ V_{I(D+)} - V_{I(D-)} $	300	-	-	mV
V_{HSCM}	high-speed data signaling common mode voltage range		-50	-	+500	mV
Output levels						
V_{HSOI}	high-speed idle level output voltage (differential)		-10	-	+10	mV
V_{HSOL}	high-speed LOW-level output voltage (differential)		-10	-	+10	mV

Table 71: Static characteristics: analog I/O pins (D+, D-)^[1]...continued $V_{CC} = 4.0$ to 5.5 V; $V_{GND} = 0$ V; $T_{amb} = -40$ to $+85$ °C; unless otherwise specified.

Symbol	Parameter	Conditions	Min	Typ	Max	Unit
V_{HSOH}	high-speed HIGH-level output voltage (differential)		360	-	440	mV
V_{CHIRPJ}	chirp-J output voltage (differential)		^[1] 700	-	1100	mV
V_{CHIRPK}	chirp-K output voltage (differential)		^[1] -900	-	-500	mV
Leakage current						
I_{LZ}	three-state leakage current		-	-	±10	µA
Capacitance						
C_{IN}	transceiver capacitance	pin to GND	-	-	10	pF
Resistance						
Z_{DRV2} ^[2]	driver output impedance for Hi-Speed USB and Original USB	steady-state drive	40.5	45	49.5	Ω
Z_{INP}	input impedance		10	-	-	MΩ
Termination						
V_{TERM}	termination voltage for pull-up resistor on pin RPU		3.0 ^[3]	-	3.6	V

[1] HS termination resistor is disabled, and pull-up resistor is connected. Occurs only during reset when both hub and device are high-speed capable.

[2] Includes internal matching resistors on both D+ and D-. This tolerance range complies with *USB specification 2.0*.

[3] In the 'suspend' mode, the minimum voltage is 2.7 V.

14. Dynamic characteristics

Table 72: Dynamic characteristics $V_{CC} = 4.0$ to 5.5 V; $V_{GND} = 0$ V; $T_{amb} = -40$ to $+85$ °C; unless otherwise specified.

Symbol	Parameter	Conditions	Min	Typ	Max	Unit
Reset						
$t_{W(RESET)}$	pulse width on input RESET	crystal oscillator running	500	-	-	µs
Crystal oscillator						
f_{XTAL}	crystal frequency		-	12	-	MHz

Table 73: Dynamic characteristics: analog I/O pins (D+, D-)^[1] $V_{CC} = 4.0$ to 5.5 V; $V_{GND} = 0$ V; $T_{amb} = -40$ to $+85$ °C; $C_L = 50$ pF; $R_{PU} = 1.5$ kΩ on D+ to V_{TERM} .; unless otherwise specified.

Symbol	Parameter	Conditions	Min.	Typ	Max	Unit
Driver characteristics						
Full-speed mode						
t_{FR}	rise time	$C_L = 50$ pF; 10 to 90% of $ V_{OH} - V_{OL} $	4	-	20	ns
t_{FF}	fall time	$C_L = 50$ pF; 90 to 10% of $ V_{OH} - V_{OL} $	4	-	20	ns
FRFM	differential rise/fall time matching (t_{FR}/t_{FF})		^[2] 90	-	111.11	%

Table 73: Dynamic characteristics: analog I/O pins (D+, D-)^[1]...continued
 $V_{CC} = 4.0$ to 5.5 V; $V_{GND} = 0$ V; $T_{amb} = -40$ to $+85$ °C; $C_L = 50$ pF; $R_{PU} = 1.5$ kΩ on D+ to $V_{TERM.}$; unless otherwise specified.

Symbol	Parameter	Conditions	Min.	Typ	Max	Unit
V_{CRS}	output signal crossover voltage		^{[2][3]} 1.3	-	2.0	V
High-speed mode						
t_{HSR}	high-speed differential rise time	with captive cable	500	-	-	ps
t_{HSF}	high-speed differential fall time	with captive cable	500	-	-	ps
Data source timing						
Full-speed mode						
t_{FEOPT}	source EOP width	see Figure 8	^[3] 160	-	175	ns
t_{FDEOP}	source differential data-to-EOP transition skew	see Figure 8	^[3] -2	-	+5	ns
Receiver timing						
Full-speed mode						
t_{JR1}	receiver data jitter tolerance to next transition	see Figure 9	^[3] -18.5	-	+18.5	ns
t_{JR2}	receiver data jitter tolerance for paired transitions	see Figure 9	^[3] -9	-	+9	ns
t_{FEOPR}	receiver SE0 width	accepted as EOP; see Figure 8	^[3] 82	-	-	ns
t_{FST}	width of SE0 during differential transition	rejected as EOP; see Figure 10	^[3] -	-	14	ns

- [1] Test circuit: see Figure 40.
- [2] Excluding the first transition from Idle state.
- [3] Characterized only, not tested. Limits guaranteed by design.

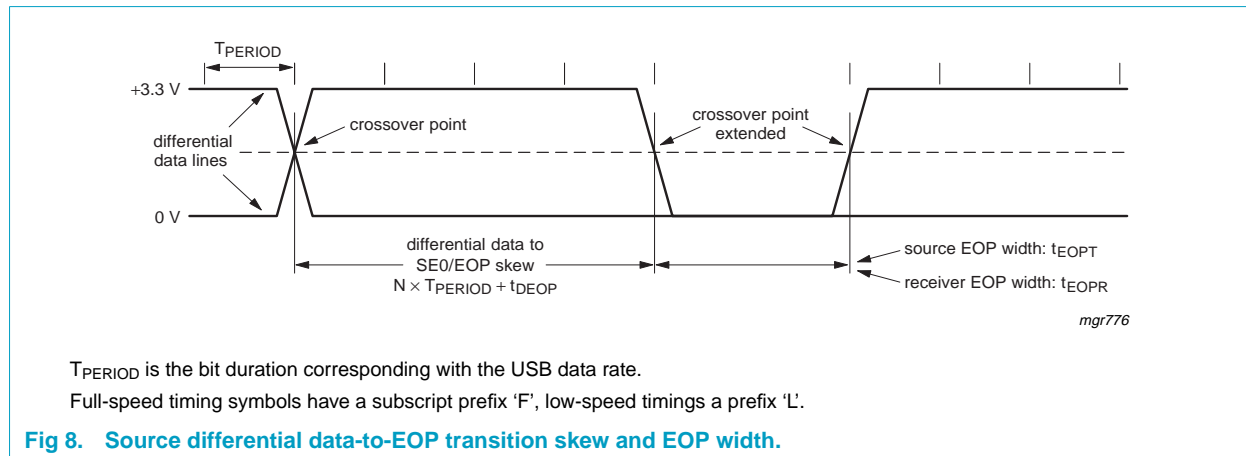

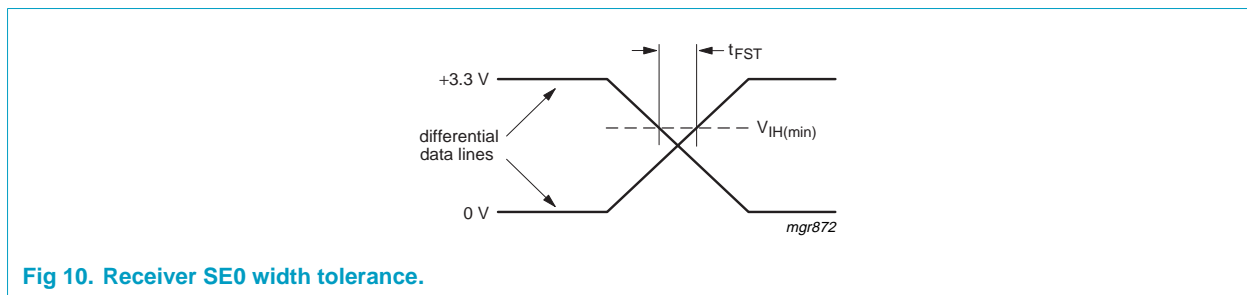
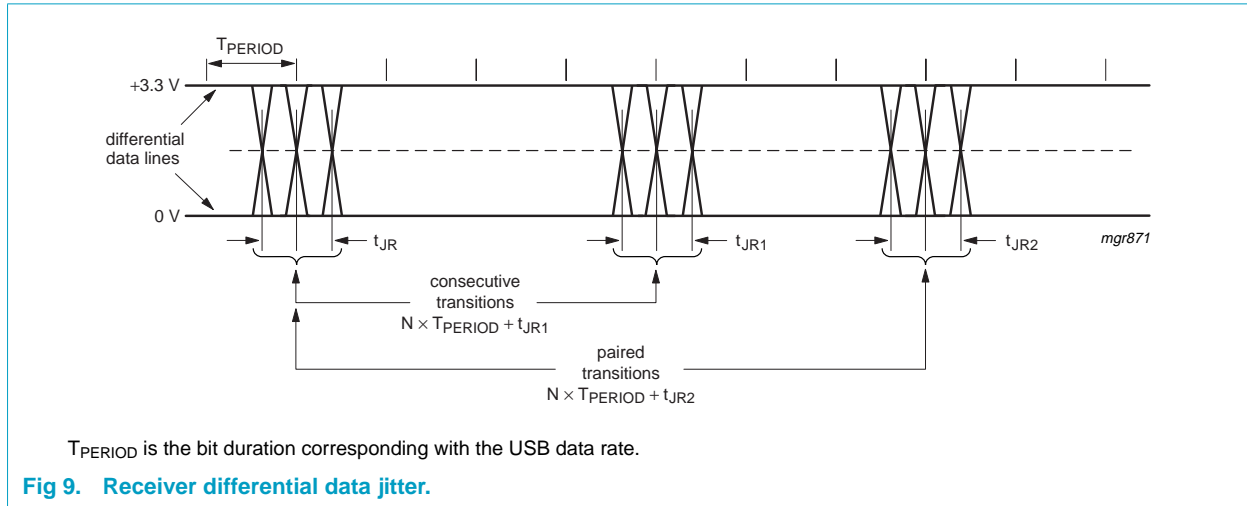

14.1 Register access timing

14.1.1 Generic Processor mode (BUS_CONF = 1)

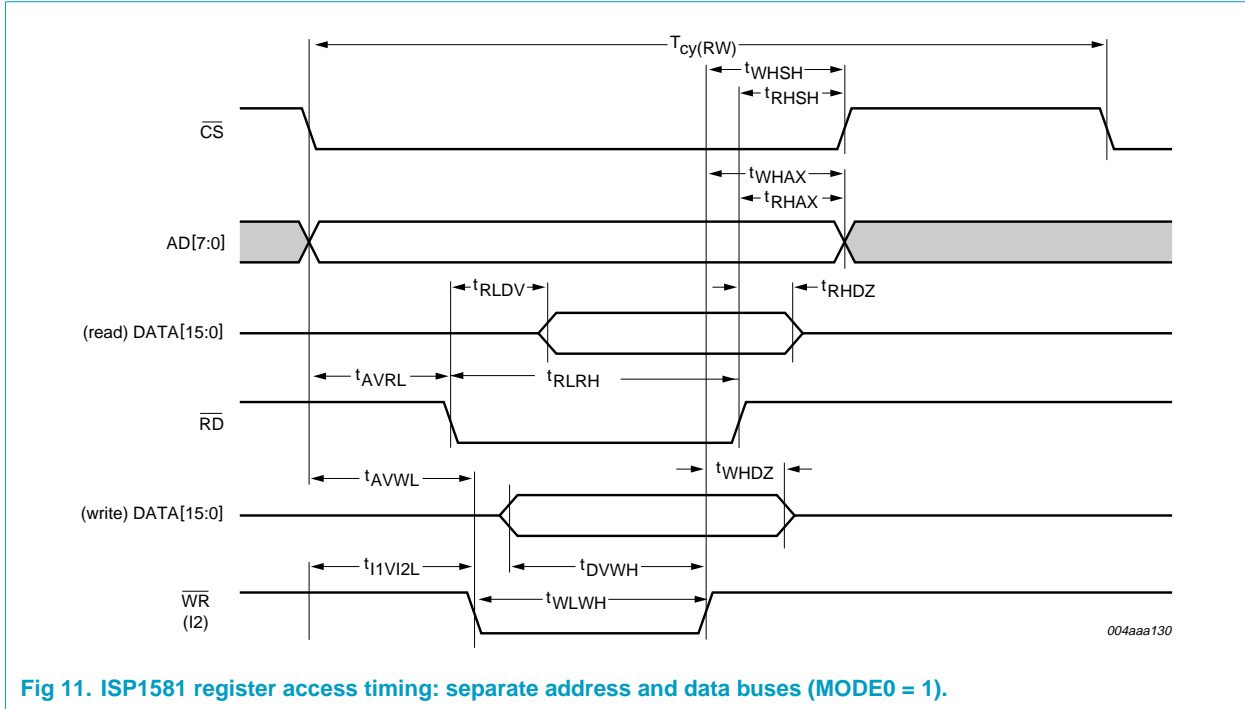

Fig 11. ISP1581 register access timing: separate address and data buses (MODE0 = 1).

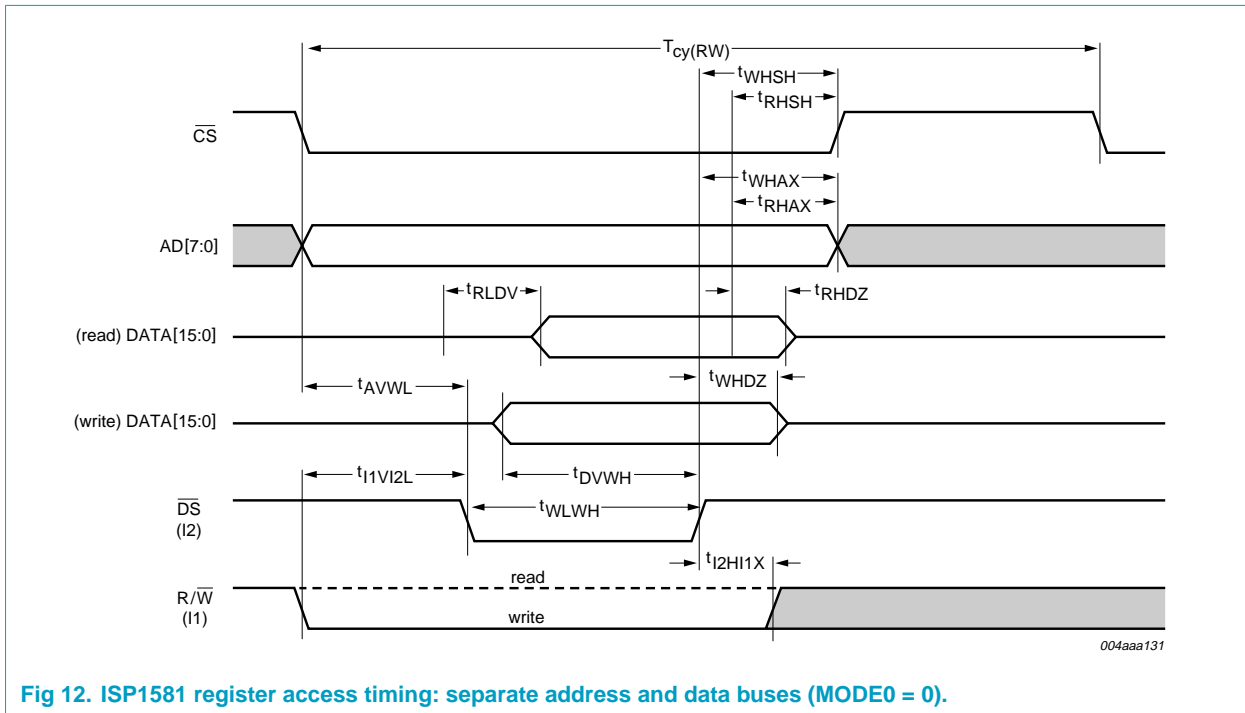

Fig 12. ISP1581 register access timing: separate address and data buses (MODE0 = 0).

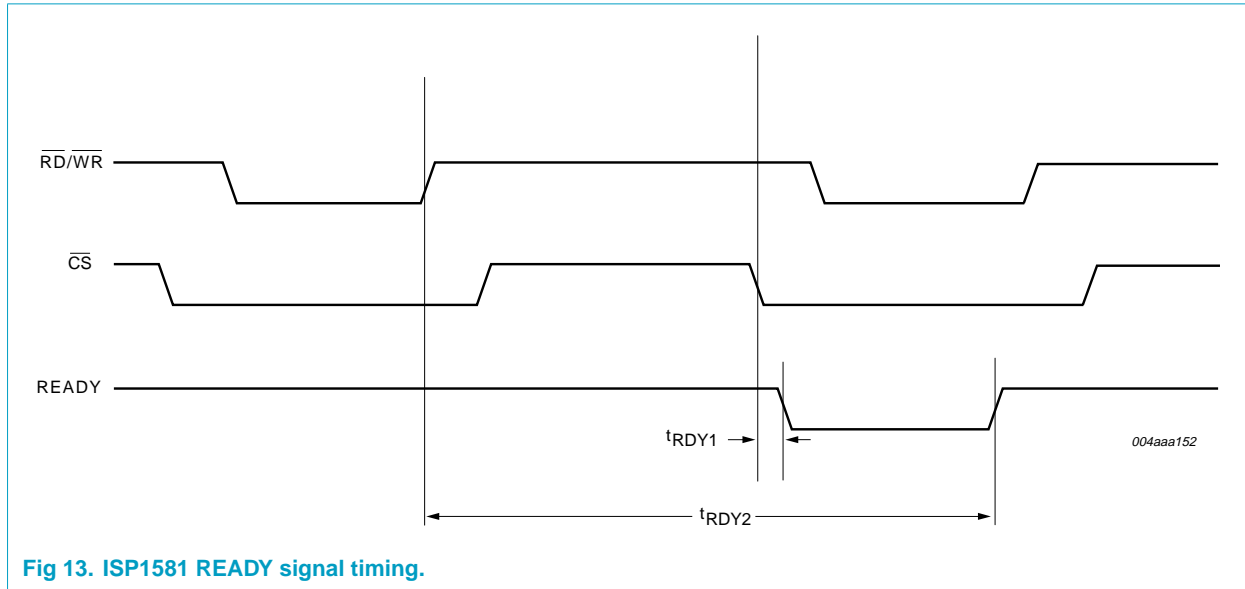

Fig 13. ISP1581 READY signal timing.

Table 74: ISP1581 register access timing parameters: separate address and data buses

$V_{CC} = 4.0$ to 5.5 V; $V_{GND} = 0$ V; $T_{amb} = -40$ to $+85$ °C.

Symbol	Parameter	Min	Max	Unit
Reading				
t_{RLRH}	\overline{RD} LOW pulse width	$>t_{RLDV}$	-	ns
t_{AVRL}	address set-up time before \overline{RD} LOW	0	-	ns
t_{RHAX}	address hold time after \overline{RD} HIGH	0	-	ns
t_{RLDV}	\overline{RD} LOW to data valid delay	-	26	ns
t_{RHDZ}	\overline{RD} HIGH to data outputs three-state delay	0	15	ns
t_{RHSH}	\overline{RD} HIGH to \overline{CS} HIGH delay	0	-	ns
Writing				
t_{WLWH}	\overline{WR} LOW pulse width	15	-	ns
t_{AVWL}	address set-up time before \overline{WR} LOW	0	-	ns
t_{WHAX}	address hold time after \overline{WR} HIGH	0	-	ns
t_{DVWH}	data set-up time before \overline{WR} HIGH	11	-	ns
t_{WHDZ}	data hold time after \overline{WR} HIGH	5	-	ns
t_{WHS}	\overline{WR} HIGH to \overline{CS} HIGH delay	0	-	ns
General				
$T_{cy(RW)}$	read/write cycle time	80	-	ns
t_{1VI2L}	R/\overline{W} set-up time before \overline{DS} LOW	0	-	ns
t_{2HI1X}	R/\overline{W} hold time after \overline{DS} HIGH	0	-	ns
t_{RDY1}	READY LOW to \overline{CS} LOW delay	-	3	ns
t_{RDY2}	READY HIGH to $\overline{RD}/\overline{WR}$ HIGH of the last access	-	91	ns

14.1.2 Split Bus mode (BUS_CONF = 0)

Split Bus mode (BUS_CONF = 0, MODE1 = 0, MODE0 = 0/1)

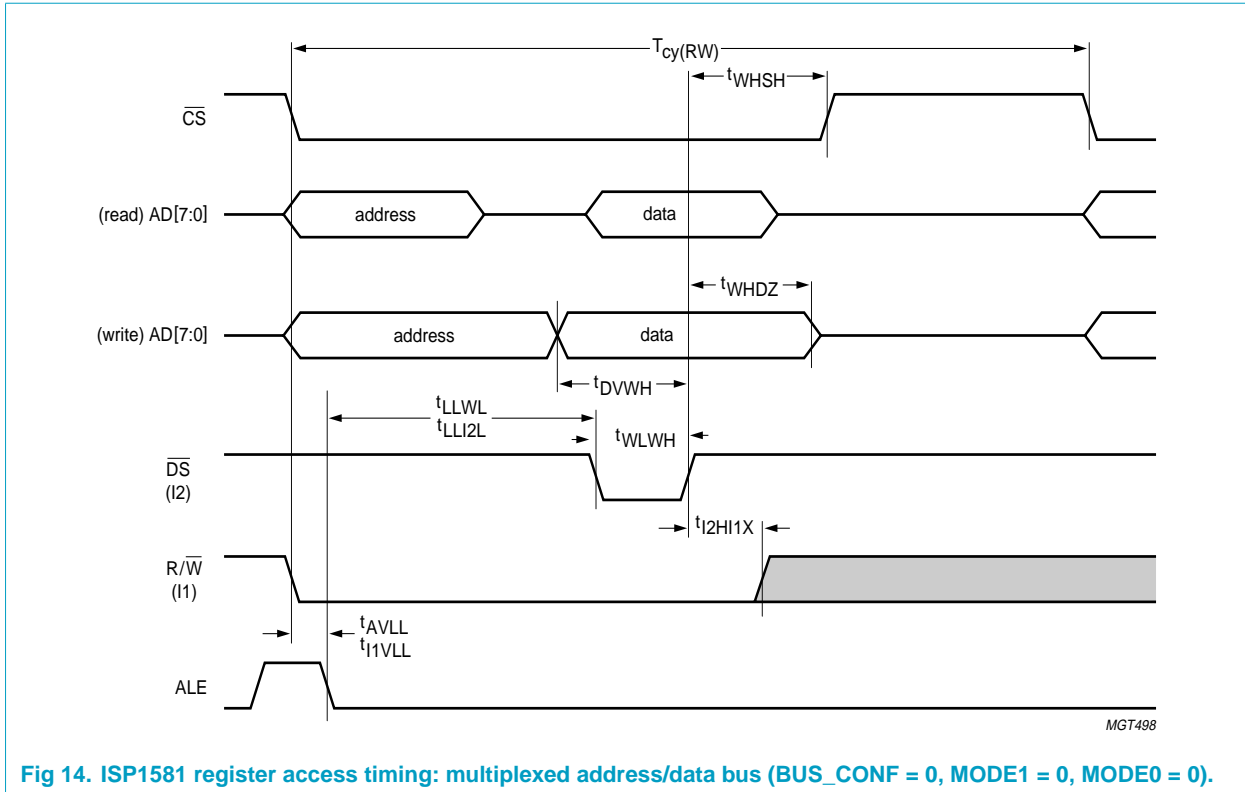

Fig 14. ISP1581 register access timing: multiplexed address/data bus (BUS_CONF = 0, MODE1 = 0, MODE0 = 0).

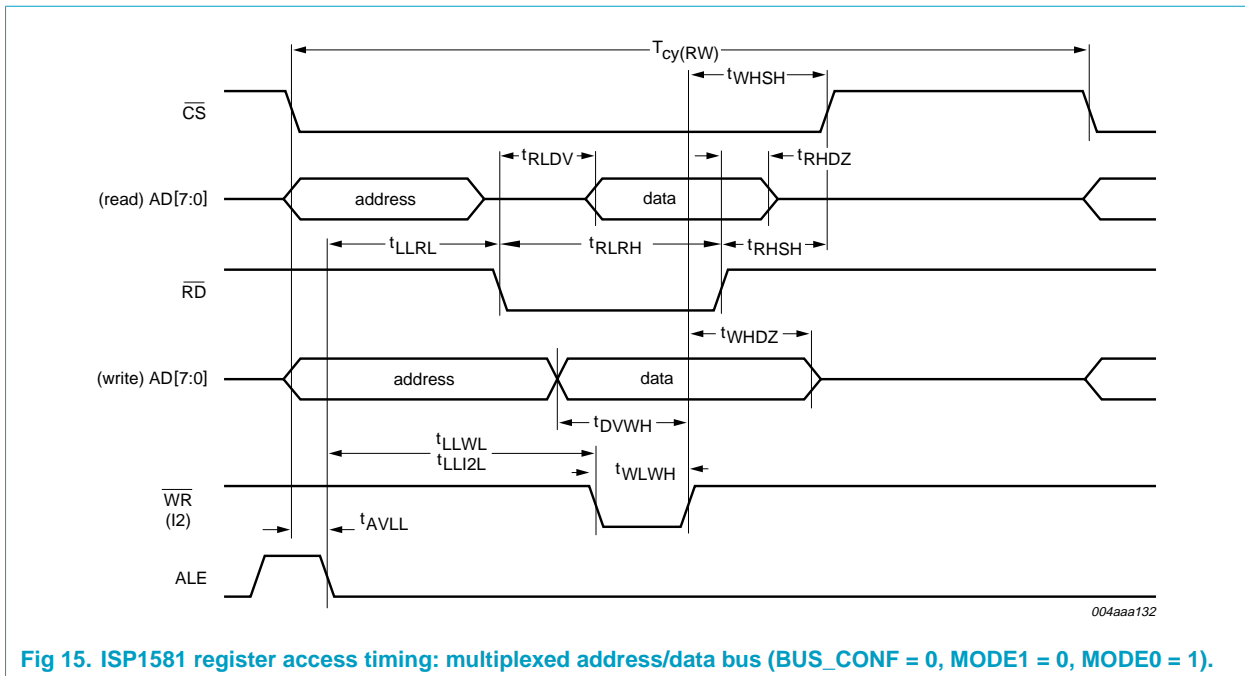

Fig 15. ISP1581 register access timing: multiplexed address/data bus (BUS_CONF = 0, MODE1 = 0, MODE0 = 1).

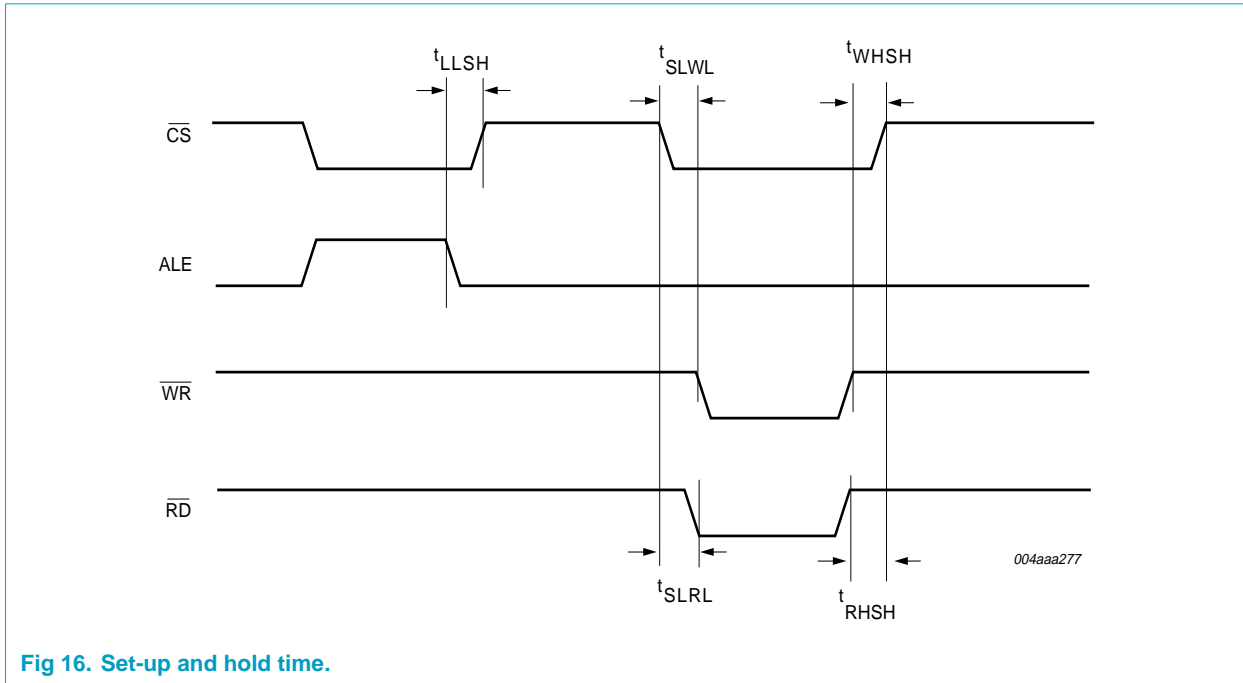

Fig 16. Set-up and hold time.

Table 75: ISP1581 register access timing parameters: multiplexed address/data bus (MODE1 = 0)

$V_{CC} = 4.0$ to 5.5 V; $V_{GND} = 0$ V; $T_{amb} = -40$ to $+85$ °C.

Symbol	Parameter	Min	Max	Unit
Reading				
t_{RLRH}	\overline{RD} LOW pulse width	$>t_{RLDV}$	-	ns
t_{RLDV}	\overline{RD} LOW to data valid delay	-	25	ns
t_{RHDZ}	\overline{RD} HIGH to data outputs three-state delay	0	15	ns
t_{RHS}	\overline{RD} HIGH to \overline{CS} HIGH delay	0	-	ns
t_{LLRL}	ALE LOW set-up time before \overline{RD} LOW	0	-	ns
Writing				
t_{WLWH}	$\overline{WR}/\overline{DS}$ LOW pulse width	15	-	ns
t_{DVWH}	data set-up time before \overline{WR} HIGH	5	-	ns
t_{LLWL}	ALE LOW to $\overline{WR}/\overline{DS}$ LOW delay	0	-	ns
t_{WHDZ}	data hold time after $\overline{WR}/\overline{DS}$ HIGH	5	-	ns
t_{WHS}	$\overline{WR}/\overline{DS}$ HIGH to \overline{CS} HIGH delay	0	-	ns
General				
$T_{cy(RW)}$	read/write cycle time	80	-	ns
t_{AVLL}	address set-up time before ALE LOW	5	-	ns
t_{1VLL}	R/\overline{W} set-up time before ALE LOW	5	-	ns
t_{LLI2L}	ALE LOW to \overline{DS} LOW delay	5	-	ns
t_{2HI1X}	R/\overline{W} hold time after \overline{DS} HIGH	5	-	ns
t_{LLSH}	ALE LOW to \overline{CS} HIGH	0	-	ns
t_{SLWL}	\overline{CS} LOW to \overline{WR} LOW	0	-	ns
t_{SLRL}	\overline{CS} LOW to \overline{RD} LOW	-	-	ns

Split Bus mode (BUS_CONF = 0, MODE1 = 1, MODE0 = 0/1)

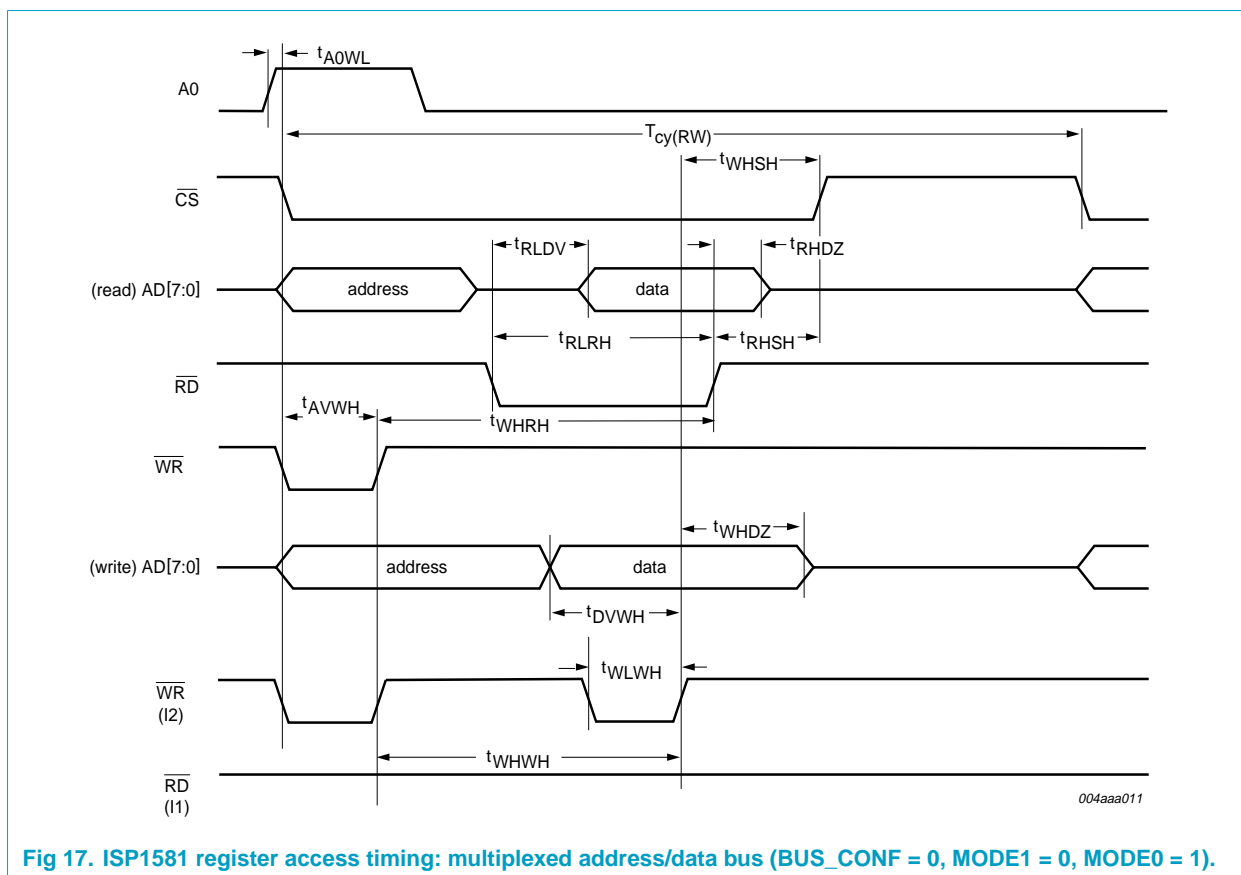

Fig 17. ISP1581 register access timing: multiplexed address/data bus (BUS_CONF = 0, MODE1 = 0, MODE0 = 1).

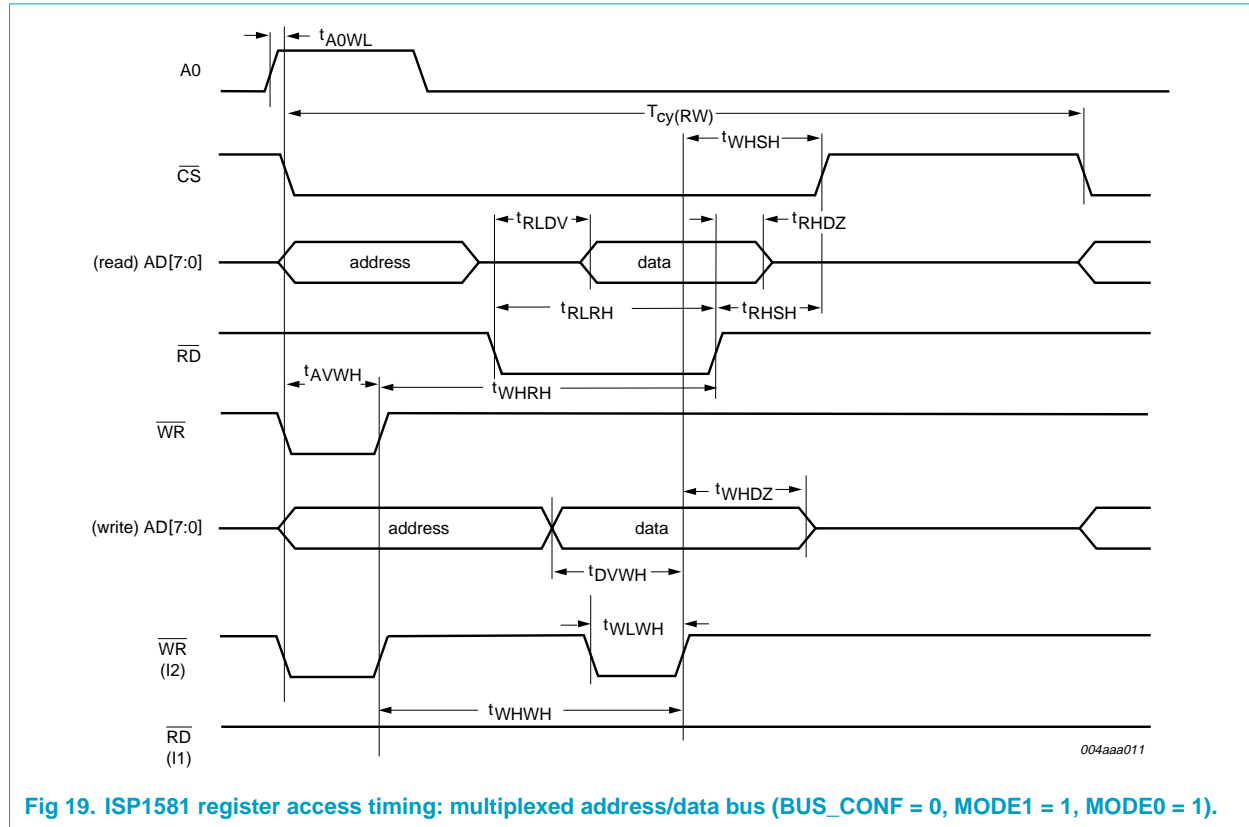

Fig 19. ISP1581 register access timing: multiplexed address/data bus (BUS_CONF = 0, MODE1 = 1, MODE0 = 1).

Table 76: ISP1581 register access timing parameters: multiplexed address/data bus (MODE1 = 1)

$V_{CC} = 4.0$ to 5.5 V; $V_{GND} = 0$ V; $T_{amb} = -40$ to $+85$ °C.

Symbol	Parameter	Min	Max	Unit
Reading				
t_{RLDV}	\overline{RD} LOW to data valid delay	-	26	ns
t_{RHDZ}	\overline{RD} HIGH to data outputs three-state delay	0	15	ns
t_{RHS}	\overline{RD} HIGH to \overline{CS} HIGH delay	0	-	ns
t_{RLRH}	\overline{RD} LOW pulse width	$>t_{RLDV}$	-	ns
t_{WHRH}	$\overline{WR}/\overline{DS}$ HIGH to \overline{RD} HIGH delay	40	-	ns
Writing				
t_{A0WL}	A0 set-up time before $\overline{WR}/\overline{DS}$ LOW	0	-	ns
t_{AVWH}	address set-up time before $\overline{WR}/\overline{DS}$ HIGH	5	-	ns
t_{DWH}	data set-up time before $\overline{WR}/\overline{DS}$ HIGH	5	-	ns
t_{WHDZ}	data hold time after $\overline{WR}/\overline{DS}$ HIGH	5	-	ns
t_{WHS}	$\overline{WR}/\overline{DS}$ HIGH to \overline{CS} HIGH delay	0	-	ns
t_{WLWH}	$\overline{WR}/\overline{DS}$ LOW pulse width	15	-	ns
t_{WHWH}	$\overline{WR}/\overline{DS}$ HIGH (address) to $\overline{WR}/\overline{DS}$ HIGH (data) delay	40	-	ns
General				
$T_{cy(RW)}$	read/write cycle time	80	-	ns
t_{I2HI1X}	R/ \overline{W} hold time after \overline{DS} HIGH	5	-	ns

14.2 DMA timing

14.2.1 PIO mode

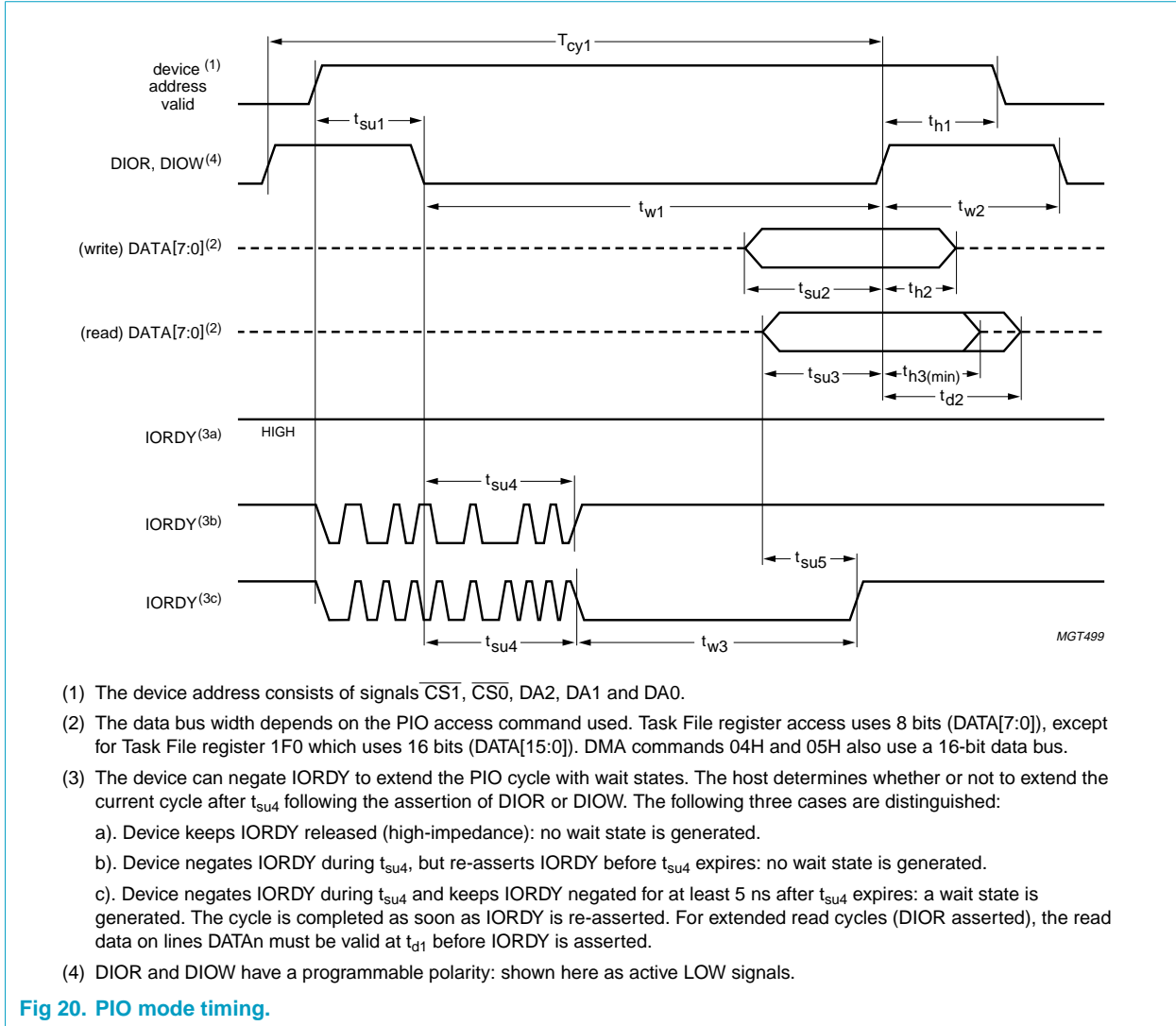

Table 77: PIO mode timing parameters

$V_{CC} = 4.0$ to 5.5 V; $V_{GND} = 0$ V; $T_{amb} = -40$ to $+85$ °C.

Symbol	Parameter	Mode 0	Mode 1	Mode 2	Mode 3	Mode 4	Unit
$T_{cy1(min)}$	read/write cycle time (minimum)	[1] 600	383	240	180	120	ns
$t_{su1(min)}$	address to DIOR/DIOw on set-up time (minimum)	70	50	30	30	25	ns
$t_{w1(min)}$	DIOR/DIOw pulse width (minimum)	[1] 165	125	100	80	70	ns
$t_{w2(min)}$	DIOR/DIOw recovery time (minimum)	[1] -	-	-	70	25	ns
$t_{su2(min)}$	data set-up time before DIOw off (minimum)	60	45	30	30	20	ns
$t_{h2(min)}$	data hold time after DIOw off (minimum)	30	20	15	10	10	ns

Table 77: PIO mode timing parameters...continued

$V_{CC} = 4.0$ to 5.5 V; $V_{GND} = 0$ V; $T_{amb} = -40$ to $+85$ °C.

Symbol	Parameter	Mode 0	Mode 1	Mode 2	Mode 3	Mode 4	Unit
$t_{su3(min)}$	data set-up time before DIOR on (minimum)	50	35	20	20	20	ns
$t_{h3(min)}$	data hold time after DIOR off (minimum)	5	5	5	5	5	ns
$t_{d2(max)}$	data to three-state delay after DIOR off (minimum)	[2] 30	30	30	30	30	ns
$t_{h1(min)}$	address hold time after DIOR/DIOW off (minimum)	20	15	10	10	10	ns
$t_{su4(min)}$	IORDY after DIOR/DIOW on set-up time (minimum)	[3] 35	35	35	35	35	ns
$t_{su5(min)}$	read data to IORDY HIGH set-up time (minimum)	[3] 0	0	0	0	0	ns
$t_{w3(max)}$	IORDY LOW pulse width (maximum)	1250	1250	1250	1250	1250	ns

- [1] T_{cy1} is the total cycle time, consisting of the command active time t_{w1} and is the command recovery (= inactive) time t_{w2} : $T_{cy1} = t_{w1} + t_{w2}$. The minimum timing requirements for T_{cy1} , t_{w1} and t_{w2} must all be met. Since $T_{cy1(min)}$ is greater than the sum of $t_{w1(min)}$ and $t_{w2(min)}$, a host implementation must lengthen t_{w1} and/or t_{w2} to ensure that T_{cy1} is equal to or greater than the value reported in the IDENTIFY DEVICE data. A device implementation shall support any legal host implementation.
- [2] t_{d2} specifies the time after DIOR is negated, when the data bus is no longer driven by the device (three-state).
- [3] If IORDY is LOW at t_{su4} , the host waits until IORDY is made HIGH before the PIO cycle is completed. In that case, t_{su5} must be met for reading (t_{su3} does not apply). When IORDY is HIGH at t_{su4} , t_{su3} must be met for reading (t_{su5} does not apply).

14.2.2 GDMA slave mode

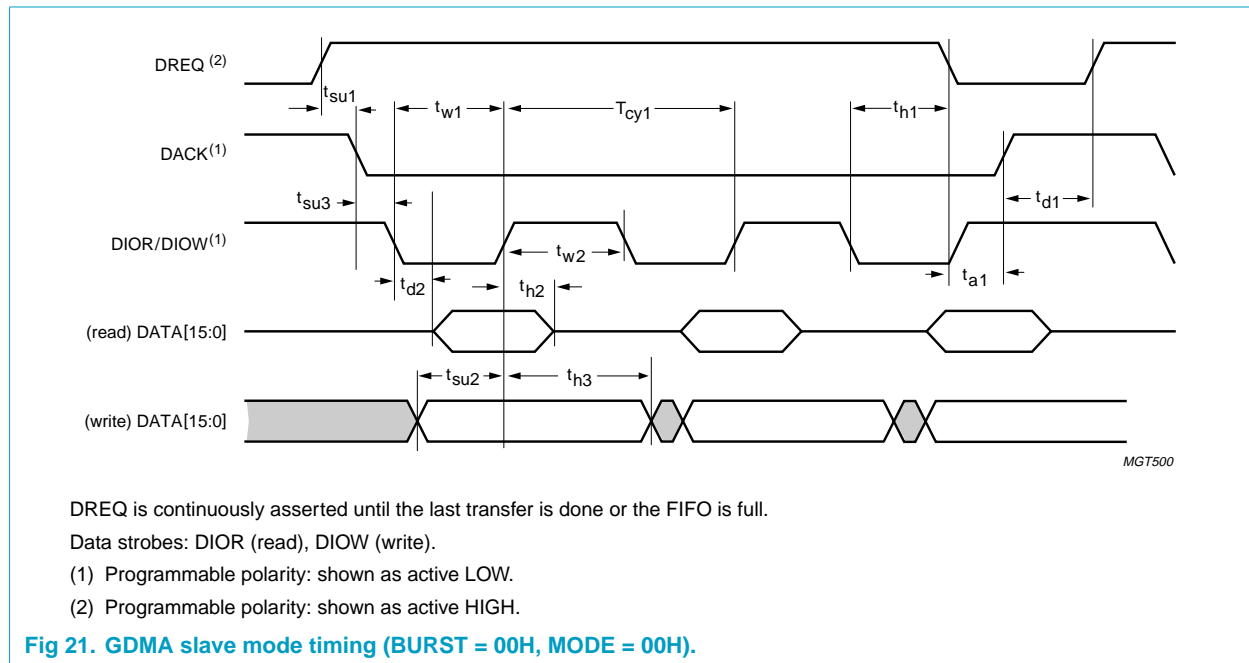

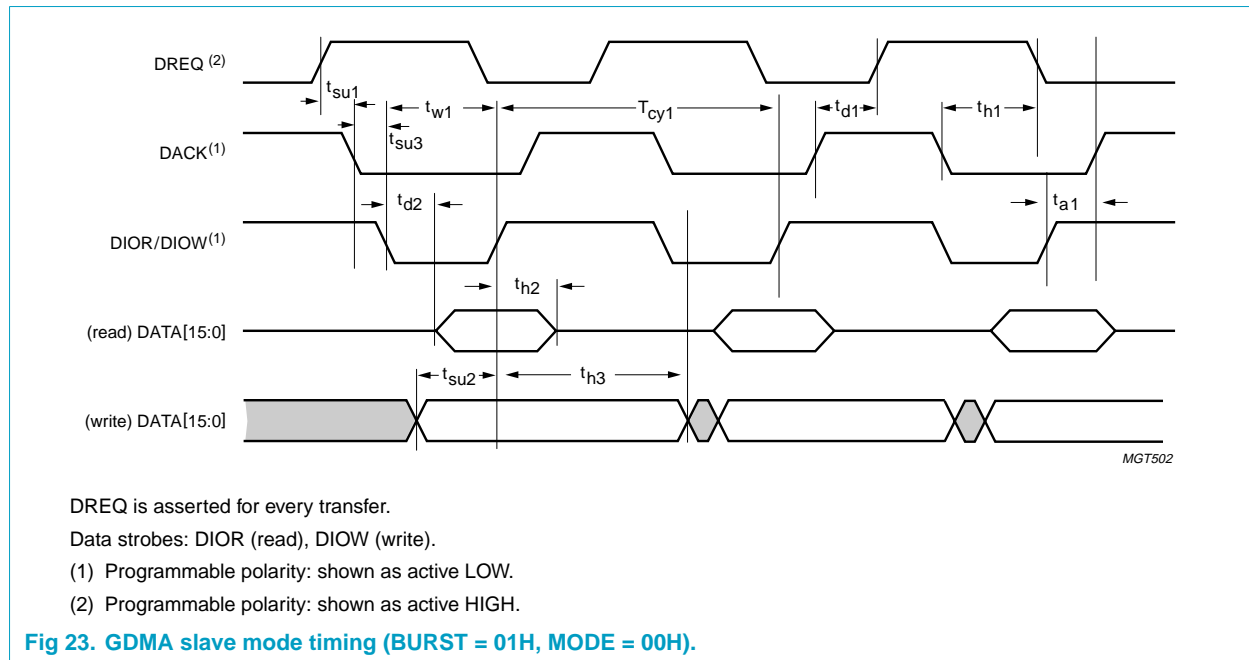
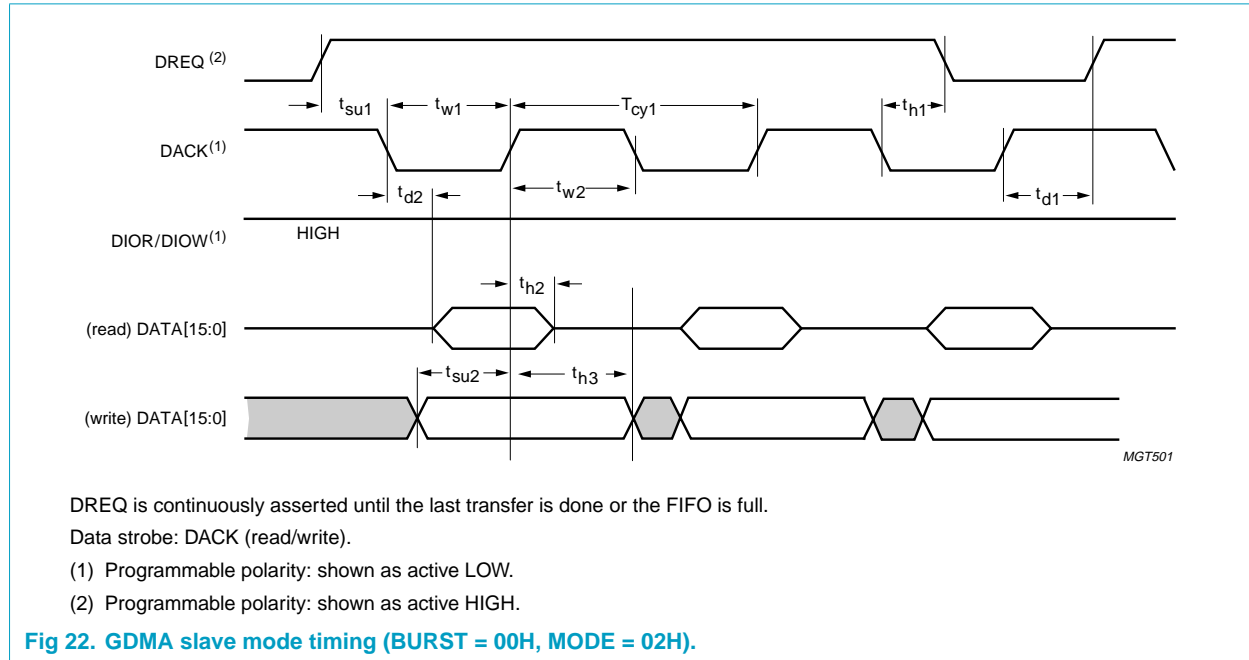

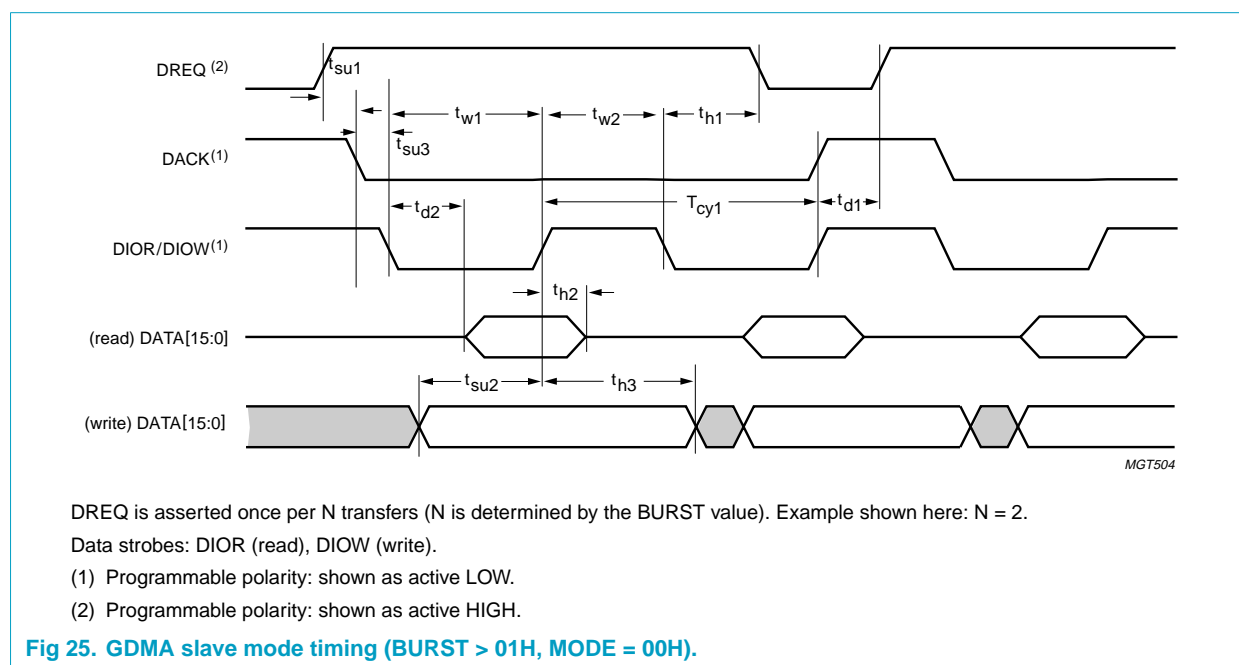
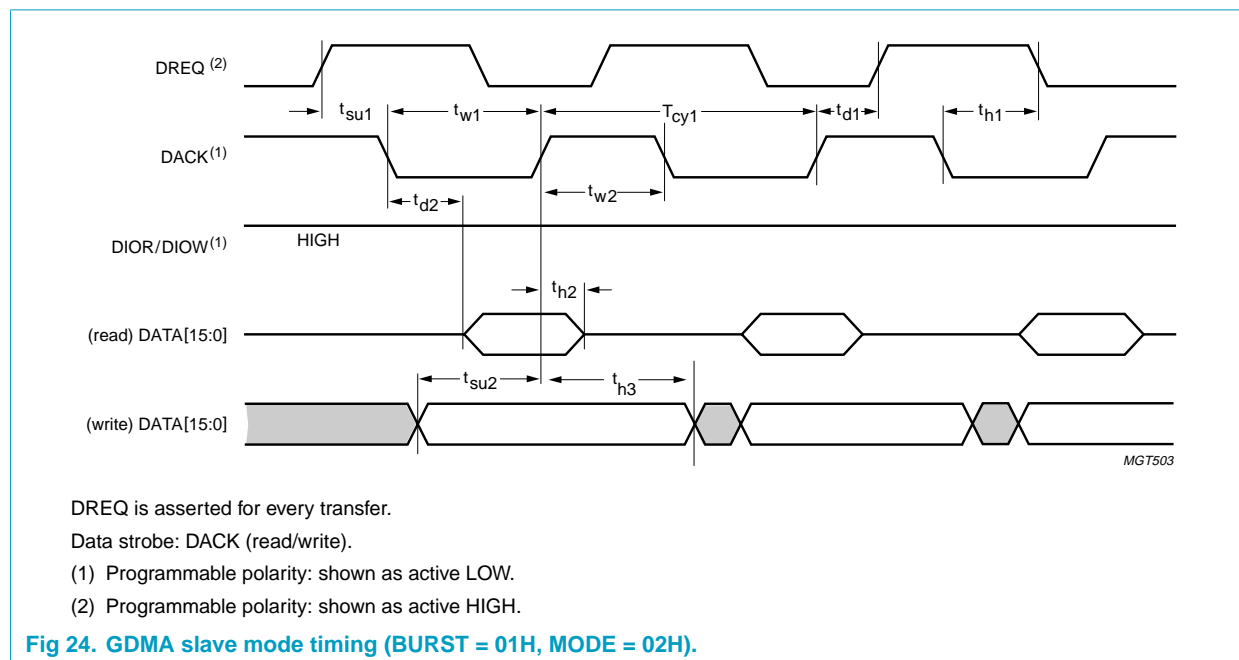

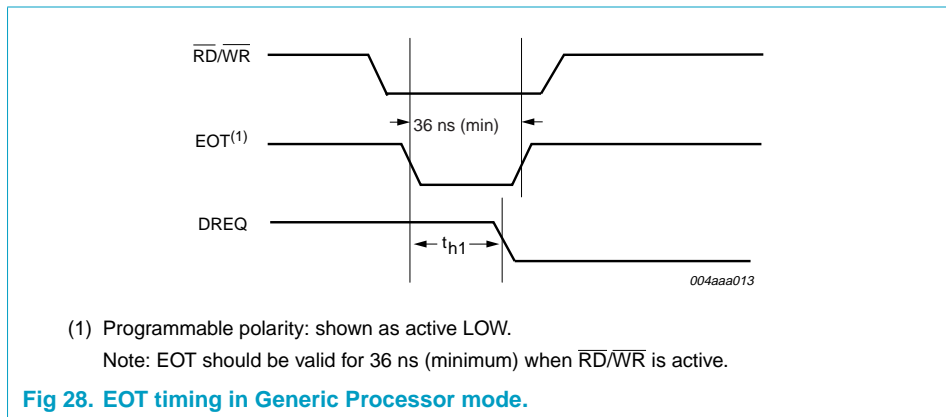
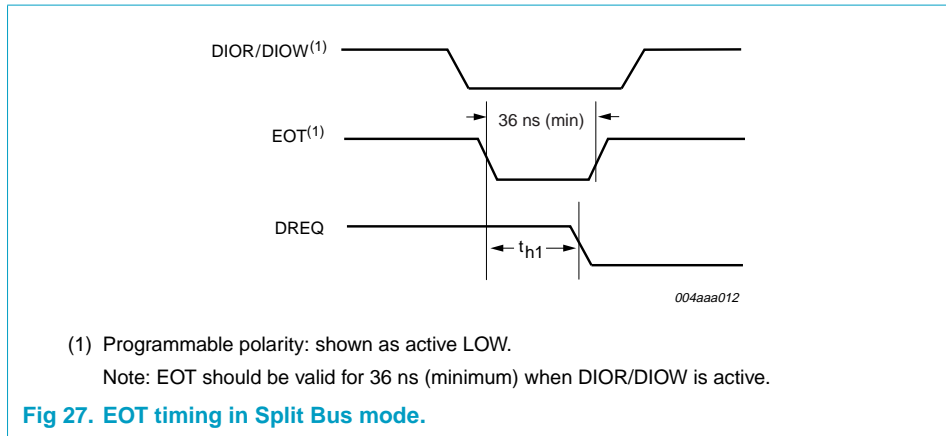
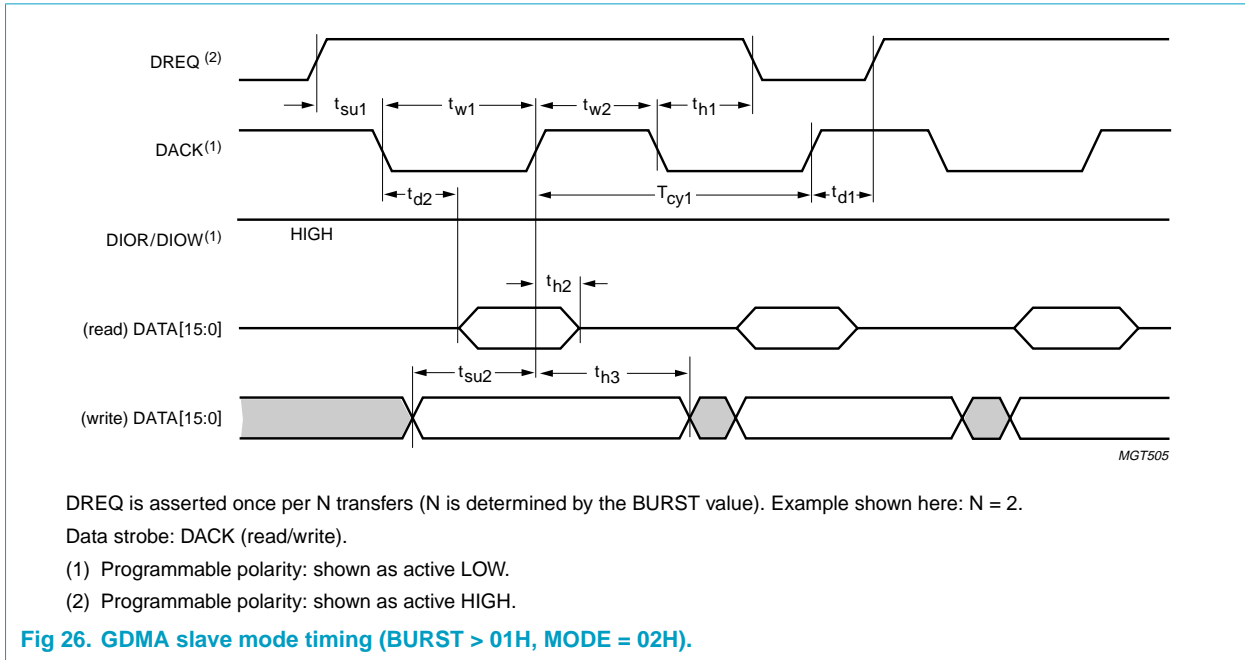

Table 78: GDMA slave mode timing parameters

$V_{CC} = 4.0$ to 5.5 V; $V_{GND} = 0$ V; $T_{amb} = -40$ to $+85$ °C.

Symbol	Parameter	Min	Max	Unit
T_{cy1}	read/write cycle time	78	-	ns
t_{su1}	DREQ set-up time before first DACK on	10	-	ns
t_{d1}	DREQ on delay after last strobe off	33.33	-	ns
t_{h1}	DREQ hold time after last strobe on	0	53	ns
t_{w1}	DIOR/DIOW pulse width	39	600	ns
t_{w2}	DIOR/DIOW recovery time	36	-	ns
t_{d2}	read data valid delay after strobe on	-	20	ns
t_{h2}	read data hold time after strobe off	-	5	ns
t_{h3}	write data hold time after strobe off	1	-	ns
t_{su2}	write data set-up time before strobe off	10	-	ns
t_{su3}	DACK setup time before DIOR/DIOW assertion	0	-	ns
t_{a1}	DACK de-assertion after DIOR/DIOW de-assertion	0	30	ns

14.2.3 MDMA mode

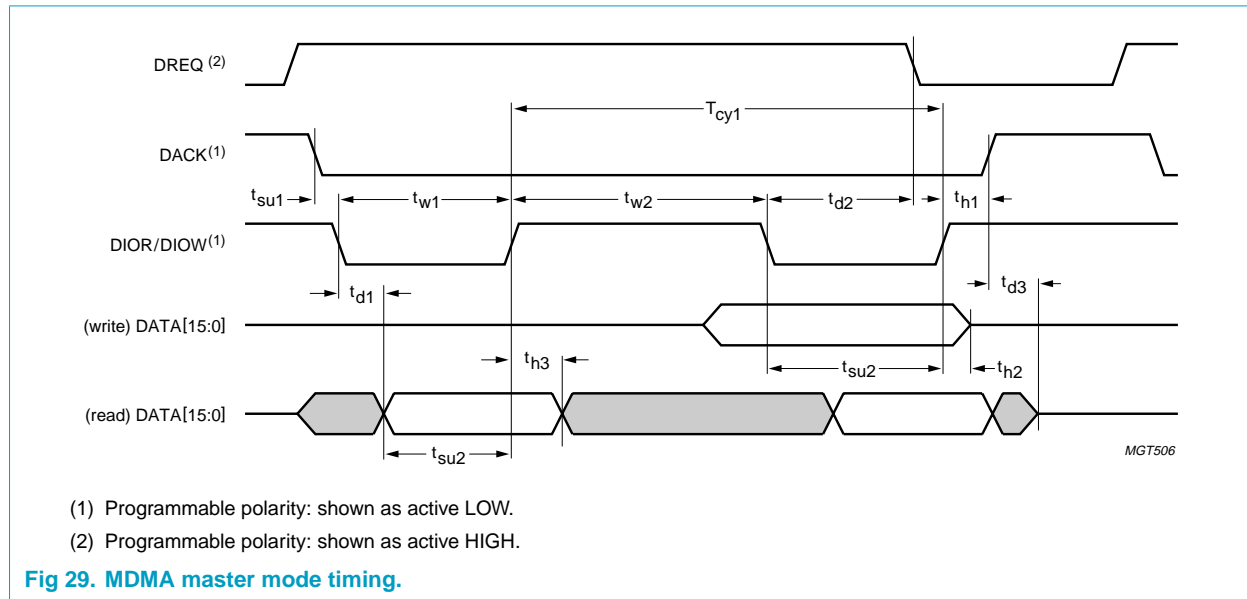

Table 79: MDMA mode timing parameters

$V_{CC} = 4.0$ to 5.5 V; $V_{GND} = 0$ V; $T_{amb} = -40$ to $+85$ °C.

Symbol	Parameter	Mode 0	Mode 1	Mode 2	Unit
$T_{cy1(min)}$	read/write cycle time (minimum) ^[1]	480	150	120	ns
$t_{w1(min)}$	DIOR/DIOW pulse width (minimum) ^[1]	215	80	70	ns
$t_{d1(max)}$	data valid delay after DIOR on (maximum)	150	60	50	ns
$t_{h3(min)}$	data hold time after DIOR off (minimum)	5	5	5	ns

Table 79: MDMA mode timing parameters...continued

$V_{CC} = 4.0$ to 5.5 V; $V_{GND} = 0$ V; $T_{amb} = -40$ to $+85$ °C.

Symbol	Parameter	Mode 0	Mode 1	Mode 2	Unit
$t_{su2(min)}$	data set-up time before DIOR/DIOW off (minimum)	100	30	20	ns
$t_{h2(min)}$	data hold time after DIOW off (minimum)	20	15	10	ns
$t_{su1(min)}$	DACK set-up time before DIOR/DIOW on (minimum)	0	0	0	ns
$t_{h1(min)}$	DACK hold time after DIOR/DIOW off (minimum)	20	5	5	ns
$t_{w2(min)}$	DIOR recovery time (minimum) ^[1]	50	50	25	ns
	DIOW recovery time (minimum) ^[1]	215	50	25	ns
$t_{d2(max)}$	DIOR on to DREQ off delay (maximum)	120	40	35	ns
	DIOW on to DREQ off delay (maximum)	40	40	35	ns
$t_{d3(max)}$	DACK off to data lines three-state delay (maximum)	20	25	25	ns

[1] T_{cy1} is the total cycle time, consisting of the command active time t_{w1} and is the command recovery (= inactive) time t_{w2} : $T_{cy1} = t_{w1} + t_{w2}$. The minimum timing requirements for T_{cy1} , t_{w1} and t_{w2} must all be met. Since $T_{cy1(min)}$ is greater than the sum of $t_{w1(min)}$ and $t_{w2(min)}$, a host implementation must lengthen t_{w1} and/or t_{w2} to ensure that T_{cy1} is equal to or greater than the value reported in the IDENTIFY DEVICE data. A device implementation shall support any legal host implementation.

14.2.4 UDMA mode

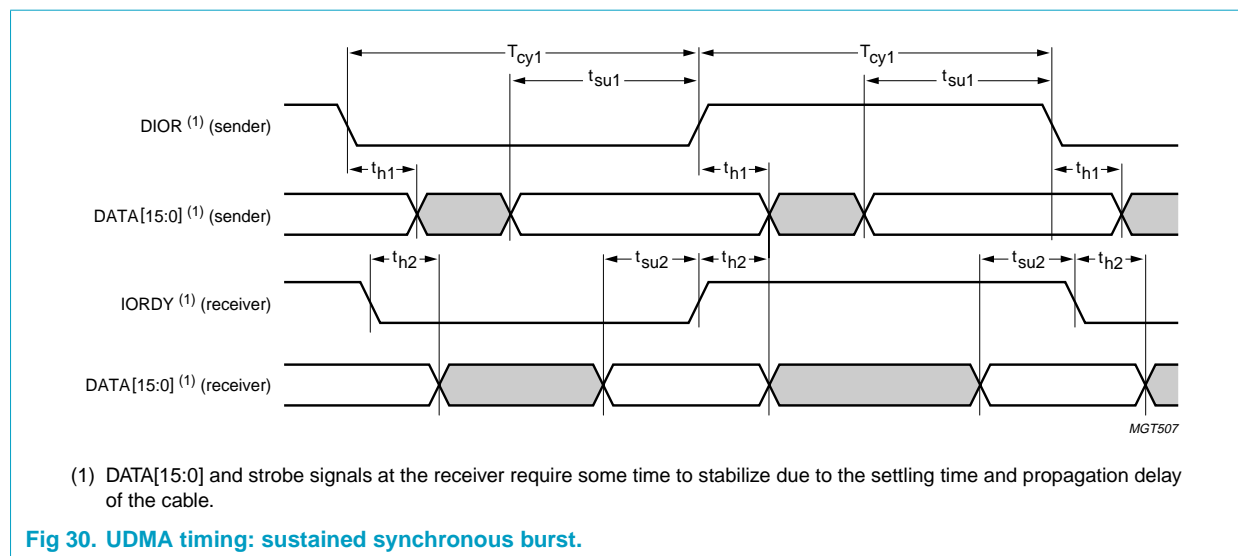
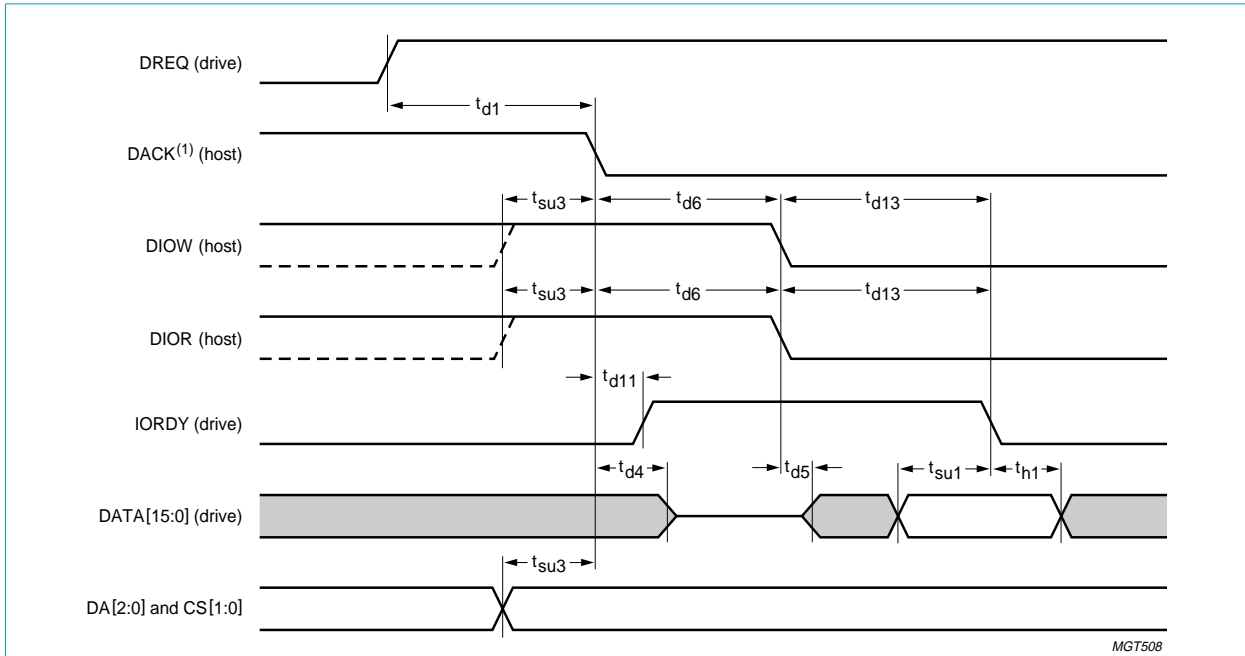
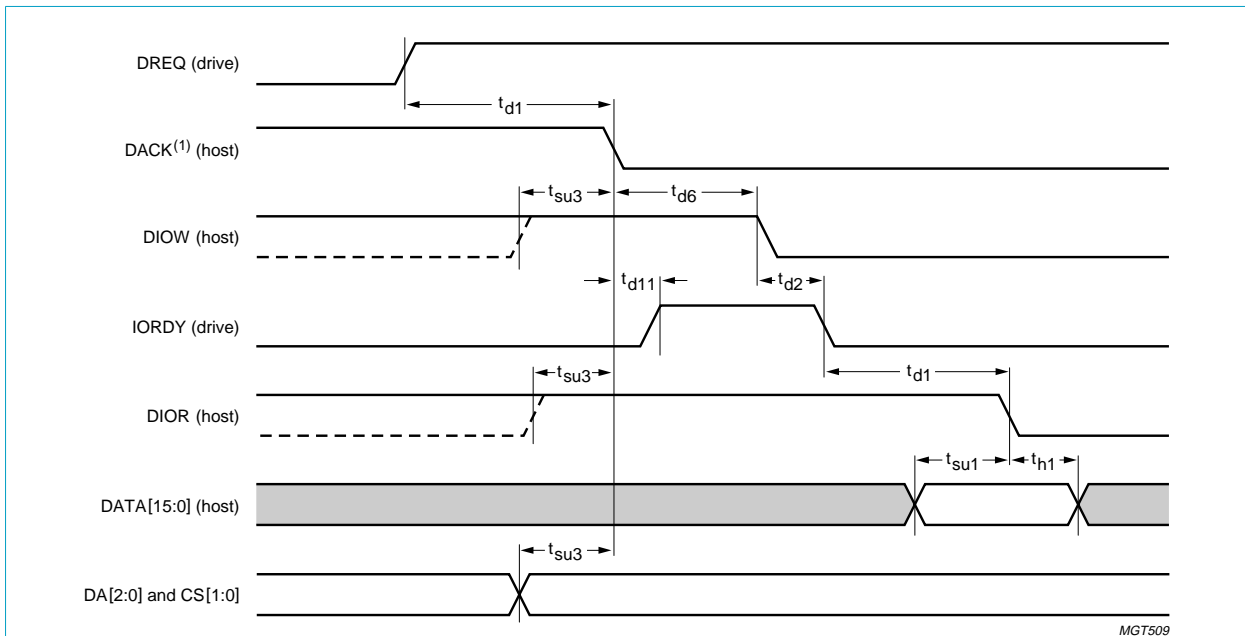

Fig 30. UDMA timing: sustained synchronous burst.



(1) Programmable polarity: shown as active LOW.

Fig 31. UDMA timing: drive initiating a burst for a read command.



(1) Programmable polarity: shown as active LOW.

Fig 32. UDMA timing: drive initiating a burst for a write command.

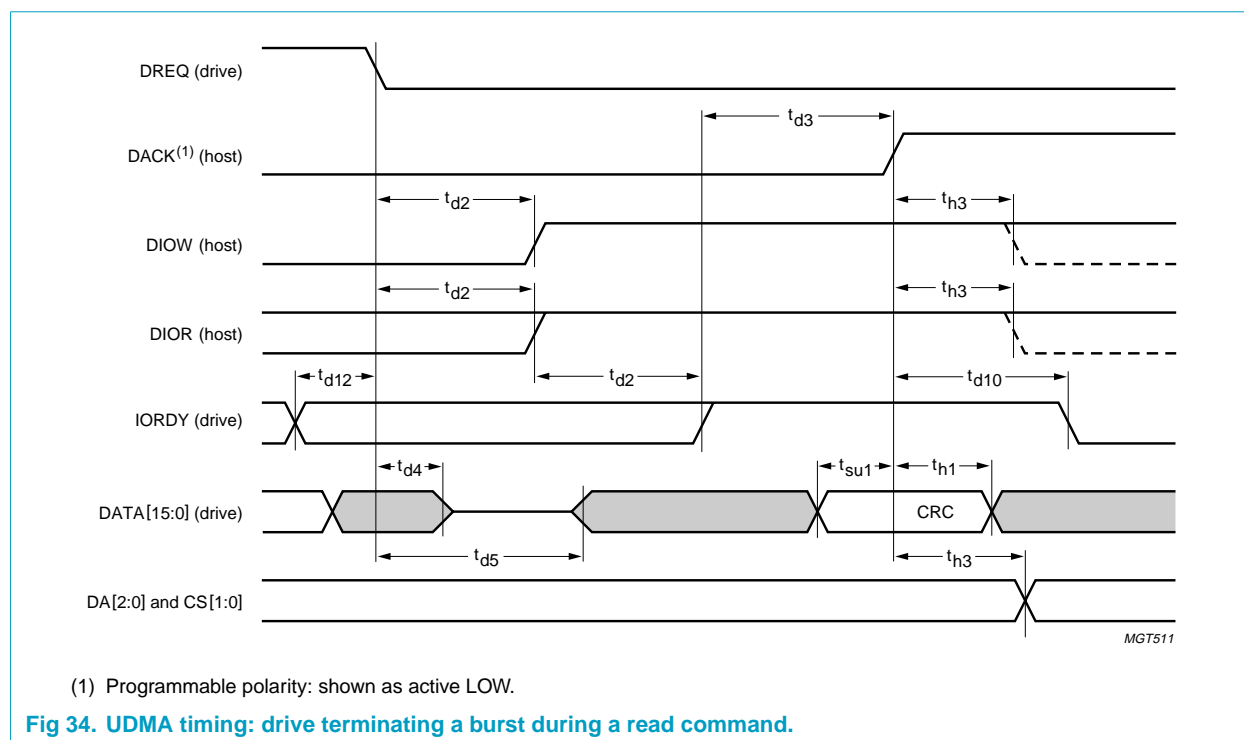
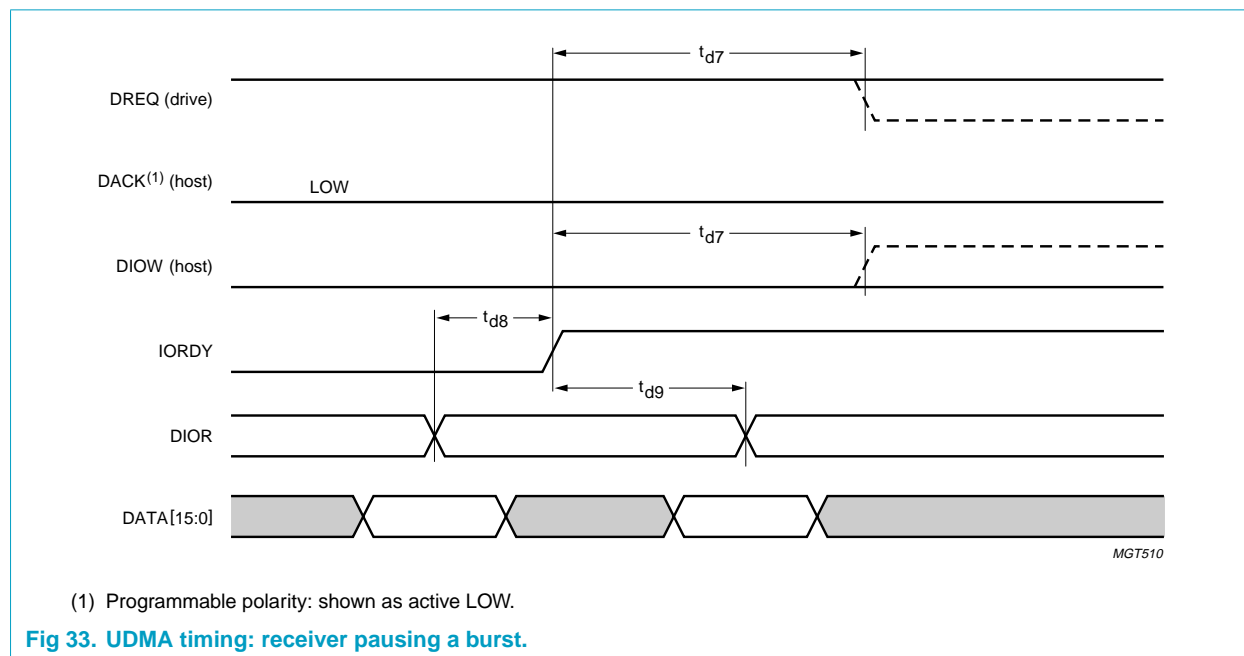

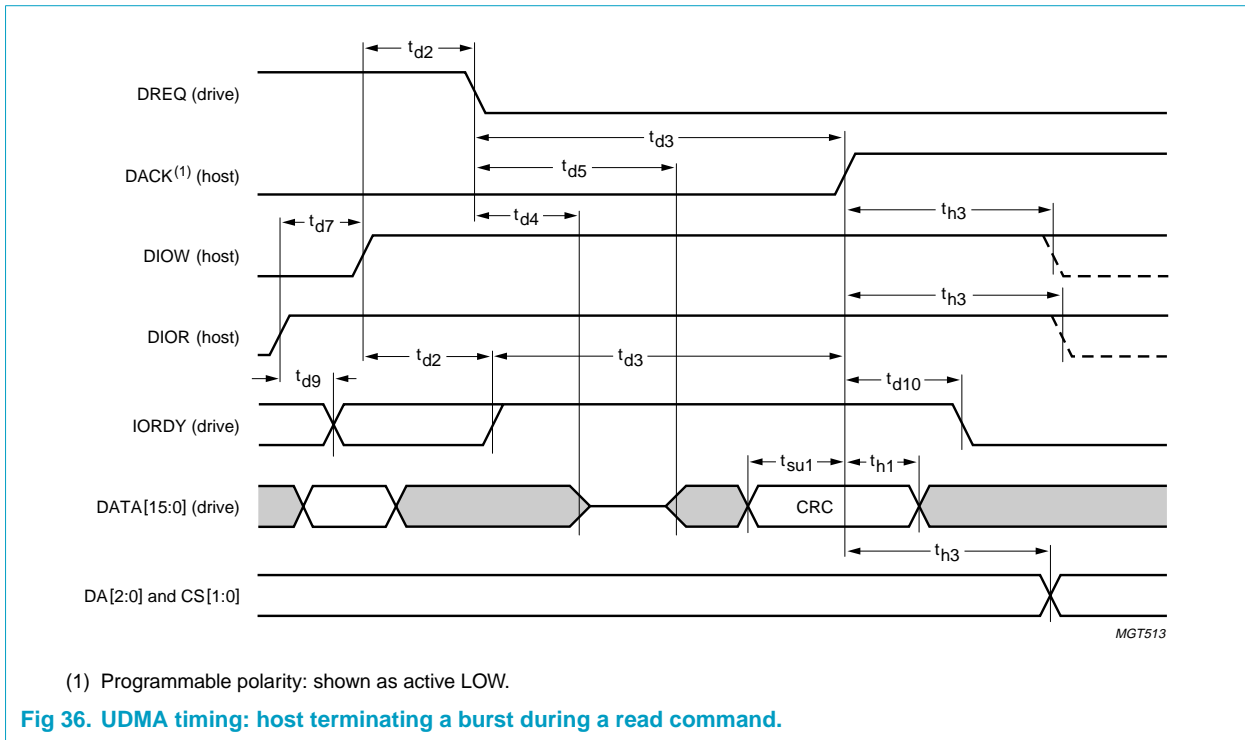
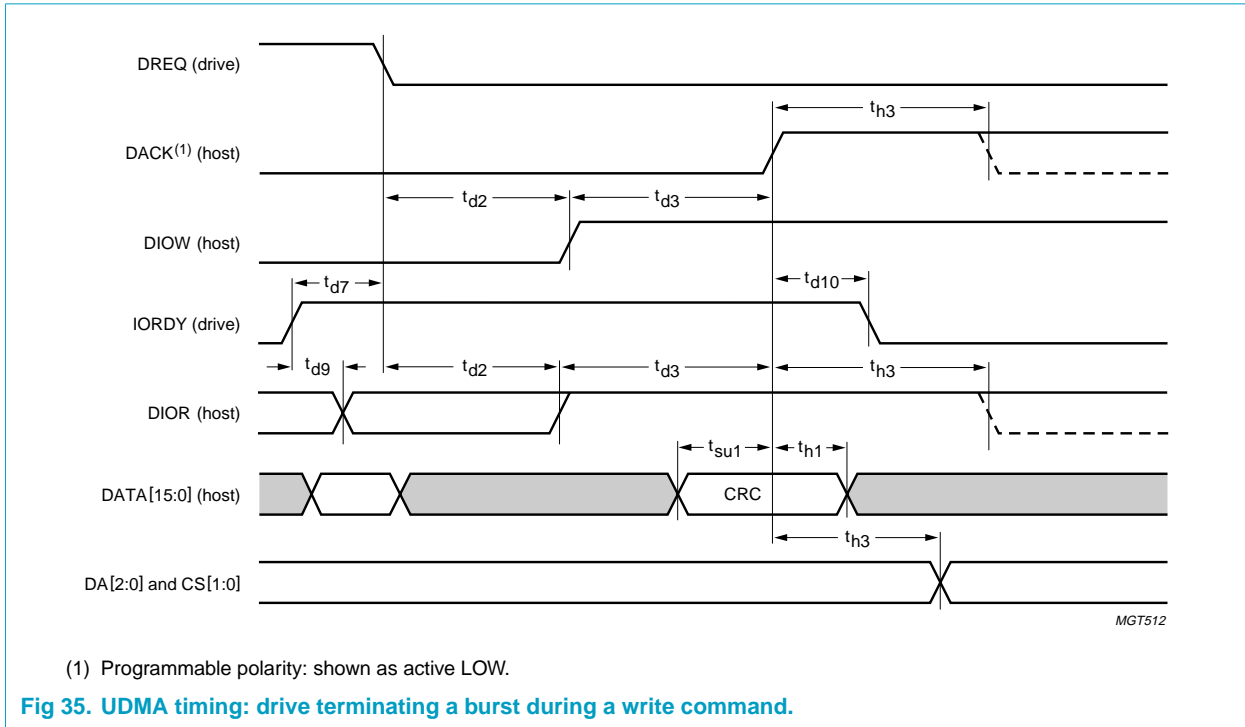

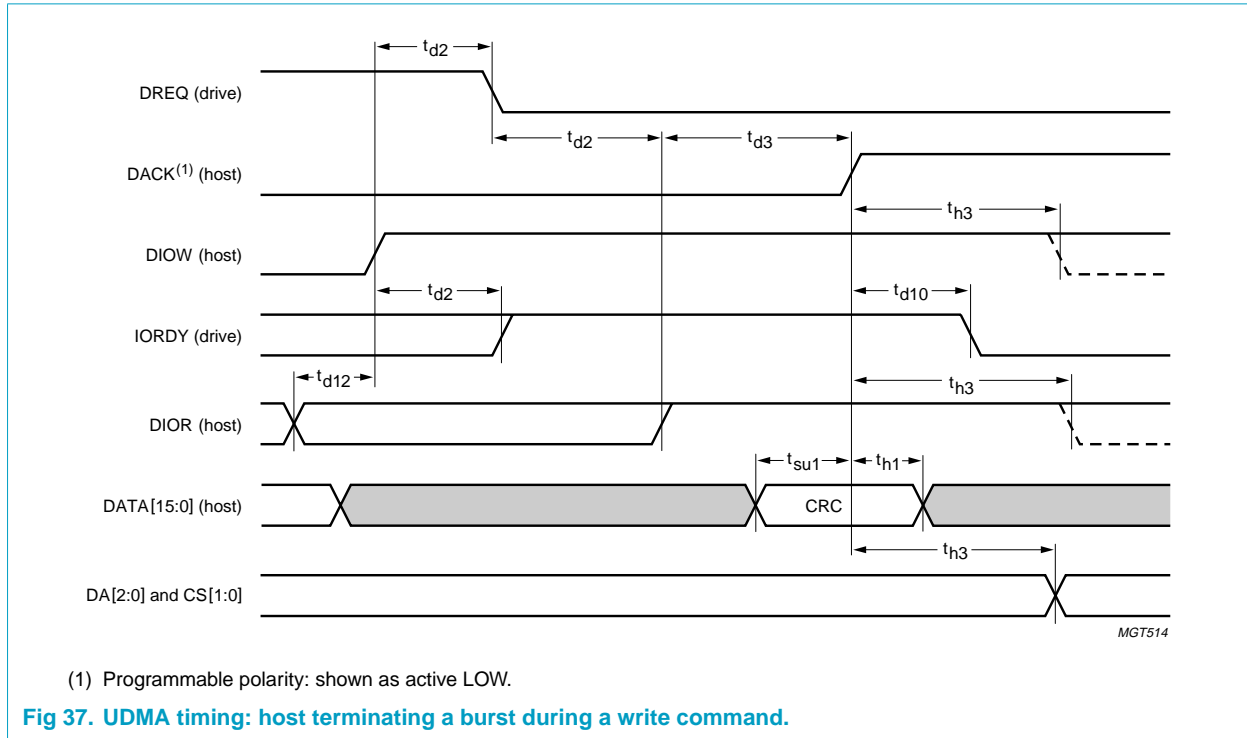

Table 80: UDMA mode timing parameters

$V_{CC} = 4.0$ to 5.5 V; $V_{GND} = 0$ V; $T_{amb} = -40$ to $+85$ °C.

Symbol	Parameter	Mode 0		Mode 1		Mode 2		Unit
		Min	Max	Min	Max	Min	Max	
T_{cy1}	read/write cycle time (from strobe edge to strobe edge)	114	-	75	-	55	-	ns
t_{su2}	data set-up time at receiver	15	-	10	-	7	-	ns
t_{h2}	data hold time at receiver	5	-	5	-	5	-	ns
t_{su1}	data set-up time at sender	70	-	48	-	34	-	ns
t_{h1}	data hold time at sender	6	-	6	-	6	-	ns
t_{d1}	unlimited interlock time ^[1]	0	-	0	-	0	-	ns
t_{d2}	limited interlock time ^[1]	0	150	0	150	0	150	ns
t_{d3}	limited interlock time with minimum ^[1]	20	-	20	-	20	-	ns
t_{d4}	data line drivers switch-off delay	-	10	-	10	-	10	ns
t_{d5}	data line drivers switch-on delay (host)	20	-	20	-	20	-	ns
	data line drivers switch-on delay (drive)	0	-	0	-	0	-	ns
t_{su3}	control signal set-up time before DACK on	20	-	20	-	20	-	ns
t_{h3}	control signal hold time after DACK off	20	-	20	-	20	-	ns
t_{d6}	DACK on to control signal transition delay	20	70	20	70	20	70	ns
t_{d7}	ready to paused delay	160	-	125	-	100	-	ns
t_{d8}	strobe to ready delay to ensure a synchronous pause	-	50	-	30	-	20	ns

Table 80: UDMA mode timing parameters...continued

$V_{CC} = 4.0$ to 5.5 V; $V_{GND} = 0$ V; $T_{amb} = -40$ to $+85$ °C.

Symbol	Parameter	Mode 0		Mode 1		Mode 2		Unit
		Min	Max	Min	Max	Min	Max	
t_{d9}	ready to final strobe edge delay	-	75	-	60	-	50	ns
t_{d10}	DACK off to IORDY high-Z delay	-	20	-	20	-	20	ns
t_{d11}	DACK on to IORDY HIGH delay	0	-	0	-	0	-	ns
t_{d12}	final strobe edge to DREQ off or DIOW on delay	50	-	50	-	50	-	ns
t_{d13}	first strobe delay after control signal on	0	230	0	200	0	170	ns

[1] Interlock time is the time allowed between an action by one agent and the following action by the other agent. An agent can be a sender or a receiver. Interlocking actions require a response signal from the other agent before processing can continue.

15. Application information

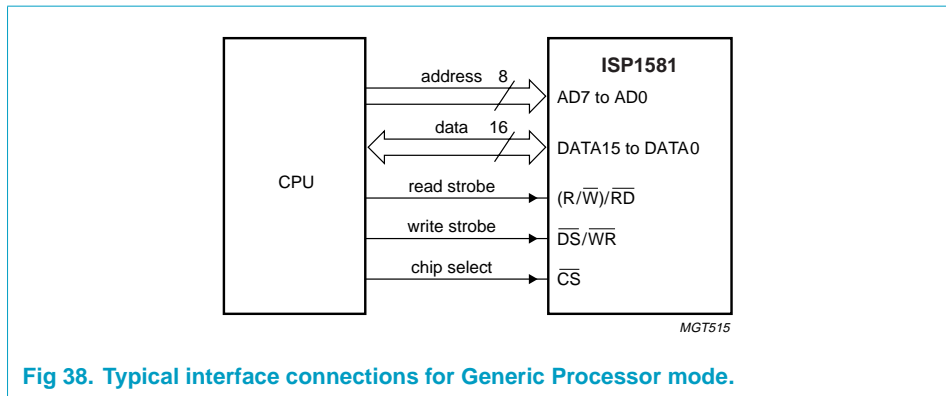

Fig 38. Typical interface connections for Generic Processor mode.

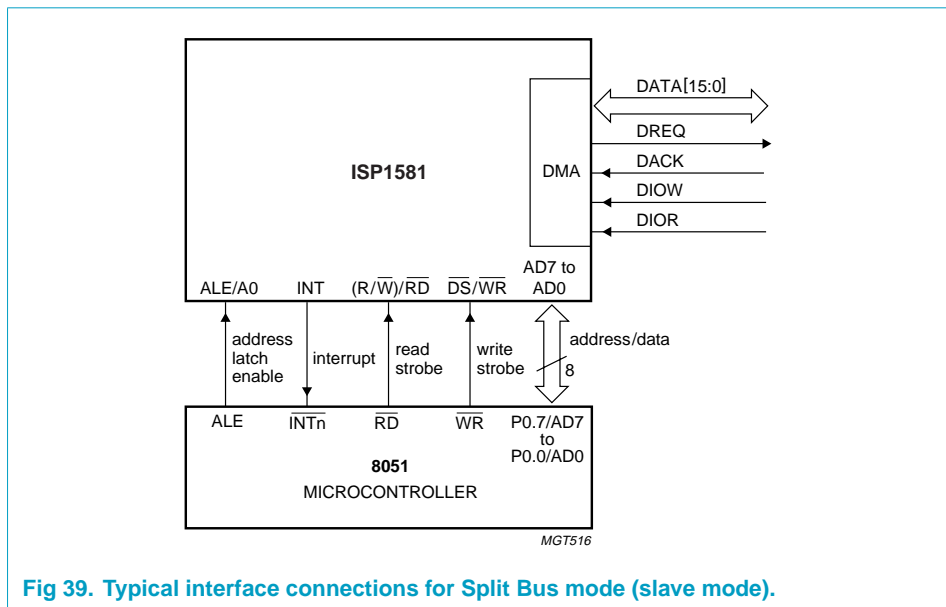
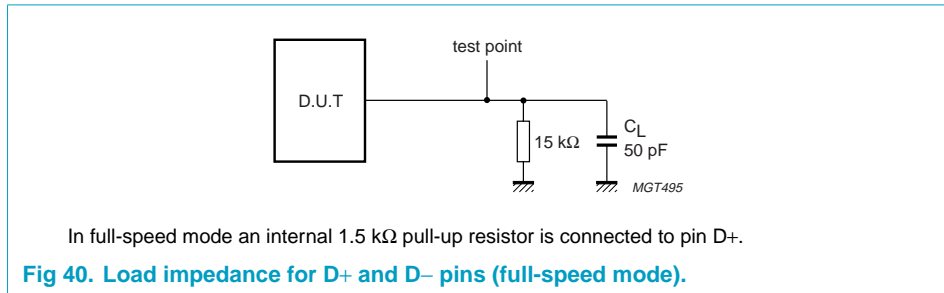

Fig 39. Typical interface connections for Split Bus mode (slave mode).

16. Test information

The dynamic characteristics of the analog I/O ports (D+, D-) as listed in [Table 73](#), were determined using the circuit shown in [Figure 40](#).



17. Package outline

LQFP64: plastic low profile quad flat package; 64 leads; body 10 x 10 x 1.4 mm

SOT314-2

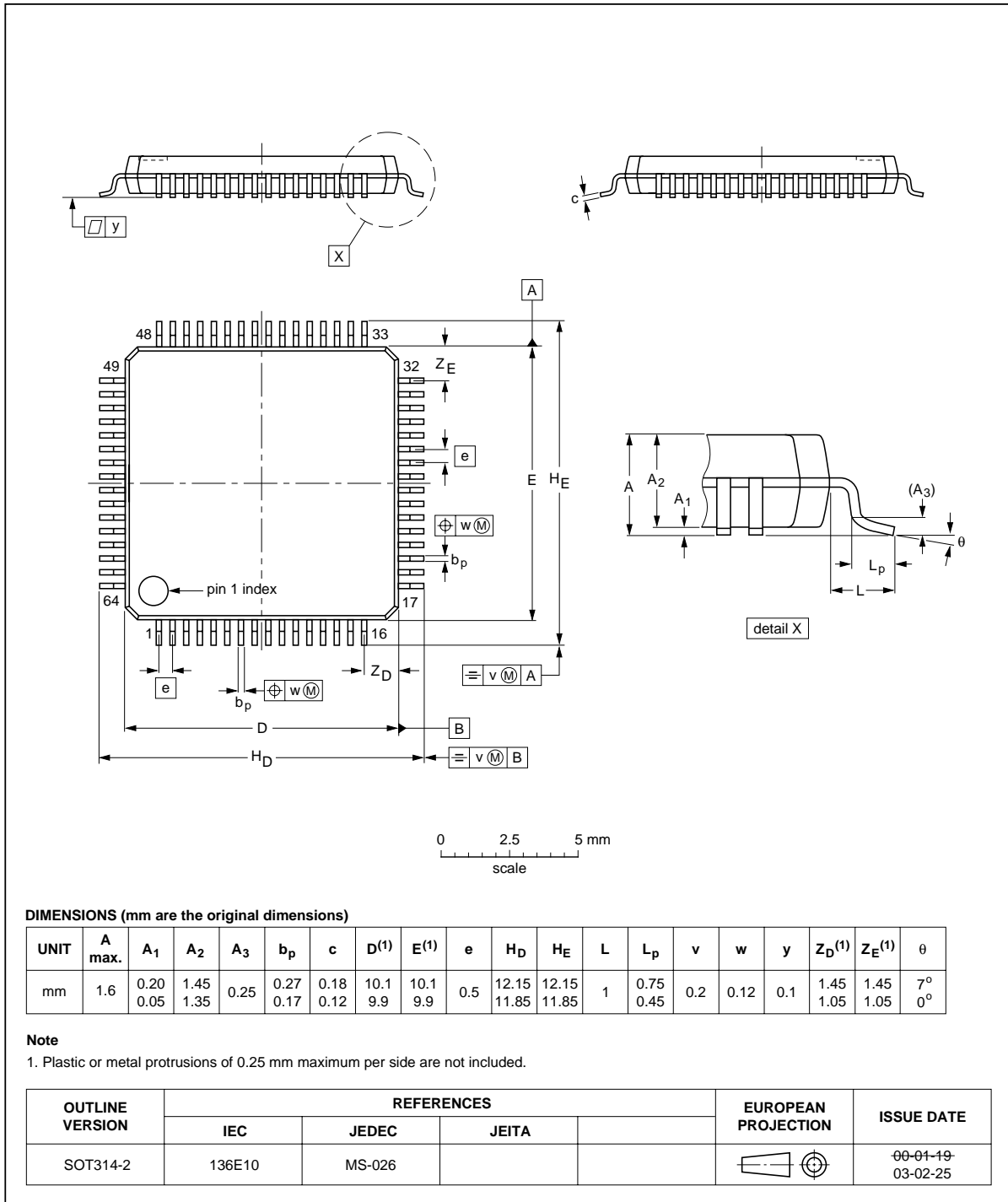

Fig 41. LQFP64 package outline.

18. Soldering

18.1 Introduction to soldering surface mount packages

This text gives a very brief insight to a complex technology. A more in-depth account of soldering ICs can be found in our *Data Handbook IC26; Integrated Circuit Packages* (document order number 9398 652 90011).

There is no soldering method that is ideal for all surface mount IC packages. Wave soldering can still be used for certain surface mount ICs, but it is not suitable for fine pitch SMDs. In these situations reflow soldering is recommended. In these situations reflow soldering is recommended.

18.2 Reflow soldering

Reflow soldering requires solder paste (a suspension of fine solder particles, flux and binding agent) to be applied to the printed-circuit board by screen printing, stencilling or pressure-syringe dispensing before package placement. Driven by legislation and environmental forces the worldwide use of lead-free solder pastes is increasing.

Several methods exist for reflowing; for example, convection or convection/infrared heating in a conveyor type oven. Throughput times (preheating, soldering and cooling) vary between 100 and 200 seconds depending on heating method.

Typical reflow peak temperatures range from 215 to 270 °C depending on solder paste material. The top-surface temperature of the packages should preferably be kept:

- below 225 °C (SnPb process) or below 245 °C (Pb-free process)
 - for all BGA, HTSSON..T and SSOP..T packages
 - for packages with a thickness ≥ 2.5 mm
 - for packages with a thickness < 2.5 mm and a volume ≥ 350 mm³ so called thick/large packages.
- below 240 °C (SnPb process) or below 260 °C (Pb-free process) for packages with a thickness < 2.5 mm and a volume < 350 mm³ so called small/thin packages.

Moisture sensitivity precautions, as indicated on packing, must be respected at all times.

18.3 Wave soldering

Conventional single wave soldering is not recommended for surface mount devices (SMDs) or printed-circuit boards with a high component density, as solder bridging and non-wetting can present major problems.

To overcome these problems the double-wave soldering method was specifically developed.

If wave soldering is used the following conditions must be observed for optimal results:

- Use a double-wave soldering method comprising a turbulent wave with high upward pressure followed by a smooth laminar wave.

- For packages with leads on two sides and a pitch (e):
 - larger than or equal to 1.27 mm, the footprint longitudinal axis is **preferred** to be parallel to the transport direction of the printed-circuit board;
 - smaller than 1.27 mm, the footprint longitudinal axis **must** be parallel to the transport direction of the printed-circuit board.

The footprint must incorporate solder thieves at the downstream end.

- For packages with leads on four sides, the footprint must be placed at a 45° angle to the transport direction of the printed-circuit board. The footprint must incorporate solder thieves downstream and at the side corners.

During placement and before soldering, the package must be fixed with a droplet of adhesive. The adhesive can be applied by screen printing, pin transfer or syringe dispensing. The package can be soldered after the adhesive is cured.

Typical dwell time of the leads in the wave ranges from 3 to 4 seconds at 250 °C or 265 °C, depending on solder material applied, SnPb or Pb-free respectively.

A mildly-activated flux will eliminate the need for removal of corrosive residues in most applications.

18.4 Manual soldering

Fix the component by first soldering two diagonally-opposite end leads. Use a low voltage (24 V or less) soldering iron applied to the flat part of the lead. Contact time must be limited to 10 seconds at up to 300 °C.

When using a dedicated tool, all other leads can be soldered in one operation within 2 to 5 seconds between 270 and 320 °C.

18.5 Package related soldering information

Table 81: Suitability of surface mount IC packages for wave and reflow soldering methods

Package ^[1]	Soldering method	
	Wave	Reflow ^[2]
BGA, HTSSON..T ^[3] , LBGA, LFBGA, SQFP, SSOP..T ^[3] , TFBGA, USON, VFBGA	not suitable	suitable
DHVQFN, HBCC, HBGA, HLQFP, HSO, HSOP, HSQFP, HSSON, HTQFP, HTSSOP, HVQFN, HVSON, SMS	not suitable ^[4]	suitable
PLCC ^[5] , SO, SOJ	suitable	suitable
LQFP, QFP, TQFP	not recommended ^{[5][6]}	suitable
SSOP, TSSOP, VSO, VSSOP	not recommended ^[7]	suitable
CWQCCN..L ^[8] , PMFP ^[9] , WQCCN..L ^[8]	not suitable	not suitable

[1] For more detailed information on the BGA packages refer to the *(LF)BGA Application Note* (AN01026); order a copy from your Philips Semiconductors sales office.

[2] All surface mount (SMD) packages are moisture sensitive. Depending upon the moisture content, the maximum temperature (with respect to time) and body size of the package, there is a risk that internal or external package cracks may occur due to vaporization of the moisture in them (the so called popcorn effect). For details, refer to the Drypack information in the *Data Handbook IC26; Integrated Circuit Packages; Section: Packing Methods*.

- [3] These transparent plastic packages are extremely sensitive to reflow soldering conditions and must on no account be processed through more than one soldering cycle or subjected to infrared reflow soldering with peak temperature exceeding $217\text{ °C} \pm 10\text{ °C}$ measured in the atmosphere of the reflow oven. The package body peak temperature must be kept as low as possible.
- [4] These packages are not suitable for wave soldering. On versions with the heatsink on the bottom side, the solder cannot penetrate between the printed-circuit board and the heatsink. On versions with the heatsink on the top side, the solder might be deposited on the heatsink surface.
- [5] If wave soldering is considered, then the package must be placed at a 45° angle to the solder wave direction. The package footprint must incorporate solder thieves downstream and at the side corners.
- [6] Wave soldering is suitable for LQFP, QFP and TQFP packages with a pitch (e) larger than 0.8 mm; it is definitely not suitable for packages with a pitch (e) equal to or smaller than 0.65 mm.
- [7] Wave soldering is suitable for SSOP, TSSOP, VSO and VSOP packages with a pitch (e) equal to or larger than 0.65 mm; it is definitely not suitable for packages with a pitch (e) equal to or smaller than 0.5 mm.
- [8] Image sensor packages in principle should not be soldered. They are mounted in sockets or delivered pre-mounted on flex foil. However, the image sensor package can be mounted by the client on a flex foil by using a hot bar soldering process. The appropriate soldering profile can be provided on request.
- [9] Hot bar soldering or manual soldering is suitable for PMFP packages.

19. Revision history

Table 82: Revision history

Rev	Date	CPCN	Description
06	20041223	200412021	Product data (9397 750 13462) Modifications: <ul style="list-style-type: none"> • Changed: “interface device” to “peripheral controller”, where applicable • Section 2 “Features”: updated the first feature list item • Table 2 “Pin description for LQFP64”: updated description for pins 11, 12, 13, 14 and 15 • Added Section 7.9 “Power-on reset” • Table 4 “Register overview”: removed loop back • Table 34 “DMA Configuration register: bit description”: added table note 1 • Section 9.5.4 “Scratch register (address: 78H)”: updated • Table 71 “Static characteristics: analog I/O pins (D+, D-)^[1]”: changed the value of C_{IN} from 20 pF to 10 pF • Removed old Section 14.1 on timing symbols.
05	20030226	-	Product data (9397 750 10766)
04	20020718	-	Product data (9397 750 09665)
03	20020218	-	Preliminary data (9397 750 09233)
02	20001023	-	Objective specification (9397 750 07648)
01	20001004	-	Objective specification (9397 750 07487)

20. Data sheet status

Level	Data sheet status ^[1]	Product status ^{[2][3]}	Definition
I	Objective data	Development	This data sheet contains data from the objective specification for product development. Philips Semiconductors reserves the right to change the specification in any manner without notice.
II	Preliminary data	Qualification	This data sheet contains data from the preliminary specification. Supplementary data will be published at a later date. Philips Semiconductors reserves the right to change the specification without notice, in order to improve the design and supply the best possible product.
III	Product data	Production	This data sheet contains data from the product specification. Philips Semiconductors reserves the right to make changes at any time in order to improve the design, manufacturing and supply. Relevant changes will be communicated via a Customer Product/Process Change Notification (CPCN).

[1] Please consult the most recently issued data sheet before initiating or completing a design.

[2] The product status of the device(s) described in this data sheet may have changed since this data sheet was published. The latest information is available on the Internet at URL <http://www.semiconductors.philips.com>.

[3] For data sheets describing multiple type numbers, the highest-level product status determines the data sheet status.

21. Definitions

Short-form specification — The data in a short-form specification is extracted from a full data sheet with the same type number and title. For detailed information see the relevant data sheet or data handbook.

Limiting values definition — Limiting values given are in accordance with the Absolute Maximum Rating System (IEC 60134). Stress above one or more of the limiting values may cause permanent damage to the device. These are stress ratings only and operation of the device at these or at any other conditions above those given in the Characteristics sections of the specification is not implied. Exposure to limiting values for extended periods may affect device reliability.

Application information — Applications that are described herein for any of these products are for illustrative purposes only. Philips Semiconductors make no representation or warranty that such applications will be suitable for the specified use without further testing or modification.

22. Disclaimers

Life support — These products are not designed for use in life support appliances, devices, or systems where malfunction of these products can reasonably be expected to result in personal injury. Philips Semiconductors

customers using or selling these products for use in such applications do so at their own risk and agree to fully indemnify Philips Semiconductors for any damages resulting from such application.

Right to make changes — Philips Semiconductors reserves the right to make changes in the products - including circuits, standard cells, and/or software - described or contained herein in order to improve design and/or performance. When the product is in full production (status 'Production'), relevant changes will be communicated via a Customer Product/Process Change Notification (CPCN). Philips Semiconductors assumes no responsibility or liability for the use of any of these products, conveys no licence or title under any patent, copyright, or mask work right to these products, and makes no representations or warranties that these products are free from patent, copyright, or mask work right infringement, unless otherwise specified.

23. Trademarks

ACPI — is an open industry specification for PC power management, co-developed by Intel Corp., Microsoft Corp. and Toshiba

Jaz — is a registered trademark of Iomega Corp.

OnNow — is a trademark of Microsoft Corp.

SoftConnect — is a trademark of Royal Philips Electronics

Zip — is a registered trademark of Iomega Corp.

Contact information

For additional information, please visit <http://www.semiconductors.philips.com>.
For sales office addresses, send e-mail to: sales.addresses@www.semiconductors.philips.com.

Fax: +31 40 27 24825

Contents

1	General description	1	9.4.6	Task File registers (addresses: 40H to 4FH) .	37
2	Features	2	9.4.7	DMA Interrupt Reason register (address: 50H)	40
3	Applications	2	9.4.8	DMA Interrupt Enable register (address: 54H)	41
4	Ordering information	2	9.4.9	DMA Endpoint register (address: 58H)	42
5	Block diagram	3	9.5	General registers	42
6	Pinning information	4	9.5.1	Interrupt register (address: 18H)	42
6.1	Pinning	4	9.5.2	Chip ID register (address: 70H)	44
6.2	Pin description	5	9.5.3	Frame Number register (address: 74H)	45
7	Functional description	11	9.5.4	Scratch register (address: 78H)	45
7.1	Hi-Speed USB transceiver	12	9.5.5	Test Mode register (address: 84H)	46
7.2	Philips Serial Interface Engine (SIE)	12	10	Power supply	46
7.3	Philips HS (High-Speed) Transceiver	12	11	Limiting values	48
7.3.1	Philips Parallel Interface Engine	12	12	Recommended operating conditions	48
7.3.2	Peripheral circuit	12	13	Static characteristics	48
7.3.3	HS detection	12	14	Dynamic characteristics	50
7.4	Voltage regulators	13	14.1	Register access timing	53
7.5	Memory Management Unit (MMU) and integrated RAM	13	14.1.1	Generic Processor mode (BUS_CONF = 1) .	53
7.6	SoftConnect	13	14.1.2	Split Bus mode (BUS_CONF = 0)	55
7.7	Microcontroller/Processor Interface and Microcontroller/Processor Handler	13	14.2	DMA timing	60
7.8	DMA Interface and DMA Handler	14	14.2.1	PIO mode	60
7.9	Power-on reset	14	14.2.2	GDMA slave mode	61
8	Modes of operation	16	14.2.3	MDMA mode	65
9	Register descriptions	16	14.2.4	UDMA mode	66
9.1	Register access	18	15	Application information	71
9.2	Initialization registers	18	16	Test information	72
9.2.1	Address register (address: 00H)	18	17	Package outline	73
9.2.2	Mode register (address: 0CH)	19	18	Soldering	74
9.2.3	Interrupt Configuration register (address: 10H)	19	18.1	Introduction to soldering surface mount packages	74
9.2.4	Interrupt Enable register (address: 14H)	20	18.2	Reflow soldering	74
9.2.5	DMA Configuration register (address: 38H)	22	18.3	Wave soldering	74
9.2.6	DMA Hardware register (address: 3CH)	22	18.4	Manual soldering	75
9.3	Data flow registers	22	18.5	Package related soldering information	75
9.3.1	Endpoint Index register (address: 2CH)	22	19	Revision history	77
9.3.2	Control Function register (address: 28H)	23	20	Data sheet status	78
9.3.3	Data Port register (address: 20H)	24	21	Definitions	78
9.3.4	Buffer Length register (address: 1CH)	25	22	Disclaimers	78
9.3.5	Endpoint MaxPacketSize register (address: 04H)	26	23	Trademarks	78
9.3.6	Endpoint Type register (address: 08H)	27			
9.3.7	Short Packet register (address: 24H)	27			
9.4	DMA registers	28			
9.4.1	DMA Command register (address: 30H)	30			
9.4.2	DMA Transfer Counter register (address: 34H)	32			
9.4.3	DMA Configuration register (address: 38H)	33			
9.4.4	DMA Hardware register (address: 3CH)	35			
9.4.5	DMA Strobe Timing register (address: 60H)	36			

© Koninklijke Philips Electronics N.V. 2004.
Printed in The Netherlands

All rights are reserved. Reproduction in whole or in part is prohibited without the prior written consent of the copyright owner.

The information presented in this document does not form part of any quotation or contract, is believed to be accurate and reliable and may be changed without notice. No liability will be accepted by the publisher for any consequence of its use. Publication thereof does not convey nor imply any license under patent- or other industrial or intellectual property rights.

Date of release: 23 December 2004

Document order number: 9397 750 13462



PHILIPS

Let's make things better.