



PSD834F2V

3.3 V supply Flash PSD for 8-bit MCUs
2 Mbit + 256 Kbit dual Flash memories and 64 Kbit SRAM

NOT FOR NEW DESIGN

FEATURES SUMMARY

- FLASH IN-SYSTEM PROGRAMMABLE (ISP) PERIPHERAL FOR 8-BIT MCUs
- 3.3 V \pm 10% SINGLE SUPPLY VOLTAGE
- 2 MBIT OF PRIMARY FLASH MEMORY (8 UNIFORM SECTORS, 32K x 8)
- 256 KBIT SECONDARY FLASH MEMORY (4 UNIFORM SECTORS)
- 64 KBIT OF SRAM
- OVER 3,000 GATES OF PLD: DPLD and CPLD
- 27 RECONFIGURABLE I/O PORTS
- ENHANCED JTAG SERIAL PORT
- PROGRAMMABLE POWER MANAGEMENT
- HIGH ENDURANCE:
 - 100,000 Erase/WRITE Cycles of Flash Memory
 - 1,000 Erase/WRITE Cycles of PLD
- Packages are ECOPACK[®]

Figure 1. Packages

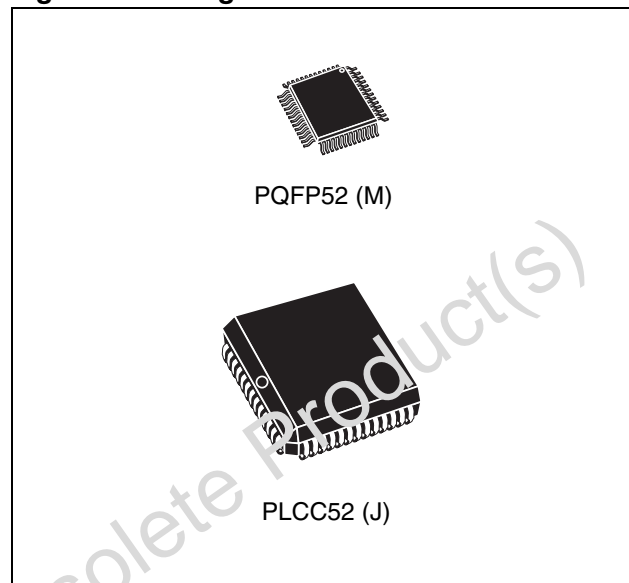

TABLE OF CONTENTS

SUMMARY DESCRIPTION	5
KEY FEATURES	6
PSD ARCHITECTURAL OVERVIEW	8
Memory	8
Page Register	8
PLDs	8
I/O Ports	8
MCU Bus Interface	8
JTAG Port	9
In-System Programming (ISP)	9
Power Management Unit (PMU)	9
DEVELOPMENT SYSTEM	10
PIN DESCRIPTION	11
PSD REGISTER DESCRIPTION AND ADDRESS OFFSET	13
DETAILED OPERATION	15
MEMORY BLOCKS	15
Primary Flash Memory and Secondary Flash memory Description	15
Memory Block Select Signals	15
INSTRUCTIONS	17
Power-down Instruction and Power-up Mode	17
READ	17
Programming Flash Memory	19
Erasing Flash Memory	21
Specific Features	22
SRAM	23
Sector Select and SRAM Select	23
Page Register	26

PLDS	27
The Turbo Bit in PSD	27
Decode PLD (DPLD)	29
Complex PLD (CPLD)	30
Output Macrocell (OMC)	32
Product Term Allocator	33
Input Macrocells (IMC)	35
MCU BUS INTERFACE	38
I/O PORTS	46
General Port Architecture	46
Port Operating Modes	47
MCU I/O Mode	47
PLD I/O Mode	47
Address Out Mode	47
Address In Mode	49
Data Port Mode	49
Peripheral I/O Mode	49
JTAG In-System Programming (ISP)	49
Port Configuration Registers (PCR)	50
Port Data Registers	51
Ports A and B – Functionality and Structure	52
Port D Structure	54
Port D – Functionality and Structure	54
Port D Structure	54
POWER MANAGEMENT	56
PLD Power Management	59
PSD Chip Select Input (CSI, PD2)	60
Input Clock	60
Input Control Signals	60

RESET TIMING AND DEVICE STATUS AT RESET 61

Warm Reset 61

I/O Pin, Register and PLD Status at Reset 61

Reset of Flash Memory Erase and Program Cycles. 61

PROGRAMMING IN-CIRCUIT USING THE JTAG SERIAL INTERFACE 63

Standard JTAG Signals. 63

JTAG Extensions. 64

Security and Flash memory Protection. 64

INITIAL DELIVERY STATE. 64

AC/DC PARAMETERS 65

MAXIMUM RATING. 68

DC AND AC PARAMETERS. 69

PACKAGE MECHANICAL 86

PART NUMBERING 91

PQFQ52 PIN ASSIGNMENTS 92

PLCC52 PIN ASSIGNMENTS. 93

REVISION HISTORY. 94

Obsolete Product(s) - Obsolete Product(s)

SUMMARY DESCRIPTION

The PSD family of memory systems for microcontrollers (MCUs) brings In-System-Programmability (ISP) to Flash memory and programmable logic. The result is a simple and flexible solution for embedded designs. PSD devices combine many of the peripheral functions found in MCU based applications.

The CPLD in the PSD devices features an optimized macrocell logic architecture. The PSD macrocell was created to address the unique requirements of embedded system designs. It allows direct connection between the system address/data bus, and the internal PSD registers, to simplify communication between the MCU and other supporting devices.

The PSD device includes a JTAG Serial Programming interface, to allow In-System Programming (ISP) of the *entire device*. This feature reduces development time, simplifies the manufacturing flow, and dramatically lowers the cost of field upgrades. Using ST's special Fast-JTAG programming, a design can be rapidly programmed into the PSD in as little as seven seconds.

The innovative PSD family solves key problems faced by designers when managing discrete Flash memory devices, such as:

- First-time In-System Programming (ISP)
- Complex address decoding
- Simultaneous READ and WRITE to the device.

The JTAG Serial Interface block allows In-System Programming (ISP), and eliminates the need for an external Boot EPROM, or an external programmer. To simplify Flash memory updates, program execution is performed from a secondary Flash memory while the primary Flash memory is being updated. This solution avoids the complicated hardware and software overhead necessary to implement IAP.

ST makes available a software development tool, PSDsoft Express, that generates ANSI-C compliant code for use with your target MCU. This code allows you to manipulate the non-volatile memory (NVM) within the PSD. Code examples are also provided for:

- Flash memory IAP via the UART of the host MCU
- Memory paging to execute code across several PSD memory pages
- Loading, reading, and manipulation of PSD macrocells by the MCU.

KEY FEATURES

- A simple interface to 8-bit microcontrollers that use either multiplexed or non-multiplexed busses. The bus interface logic uses the control signals generated by the microcontroller automatically when the address is decoded and a READ or WRITE is performed. A partial list of the MCU families supported include:
 - Intel 8031, 80196, 80186, 80C251, and 80386EX
 - Motorola 68HC11, 68HC16, 68HC12, and 683XX
 - Philips 8031 and 8051XA
 - Zilog Z80 and Z8
- Internal 2 Mbit Flash memory. This is the main Flash memory. It is divided into 8 equal-sized blocks that can be accessed with user-specified addresses.
- Internal secondary 256 Kbit Flash boot memory. It is divided into 4 equal-sized blocks that can be accessed with user-specified addresses. This secondary memory brings the ability to execute code and update the main Flash *concurrently*.
- Internal 64 Kbit SRAM.
- CPLD with 16 Output macrocells (OMCs) and 24 Input macrocells (IMCs). The CPLD may be used to efficiently implement a variety of logic functions for internal and external control. Examples include state machines, loadable shift registers, and loadable counters.
- Decode PLD (DPLD) that decodes address for selection of internal memory blocks.
- 27 individually configurable I/O port pins that can be used for the following functions:
 - MCU I/Os
 - PLD I/Os
 - Latched MCU address output
 - Special function I/Os.
 - 16 of the I/O ports may be configured as open-drain outputs.
- Standby current as low as 25µA.
- Built-in JTAG compliant serial port allows full-chip In-System Programmability (ISP). With it, you can program a blank device or reprogram a device in the factory or the field.
- Internal page register that can be used to expand the microcontroller address space by a factor of 256.
- Internal programmable Power Management Unit (PMU) that supports a low power mode called Power Down Mode. The PMU can automatically detect a lack of microcontroller activity and put the PSD into Power-down mode.
- Erase/WRITE cycles:
 - Flash memory – 100,000 minimum
 - PLD – 1,000 minimum
 - Data Retention: 15 year minimum (for Main Flash memory, Boot, PLD and Configuration bits)

Figure 2. PSD Block Diagram

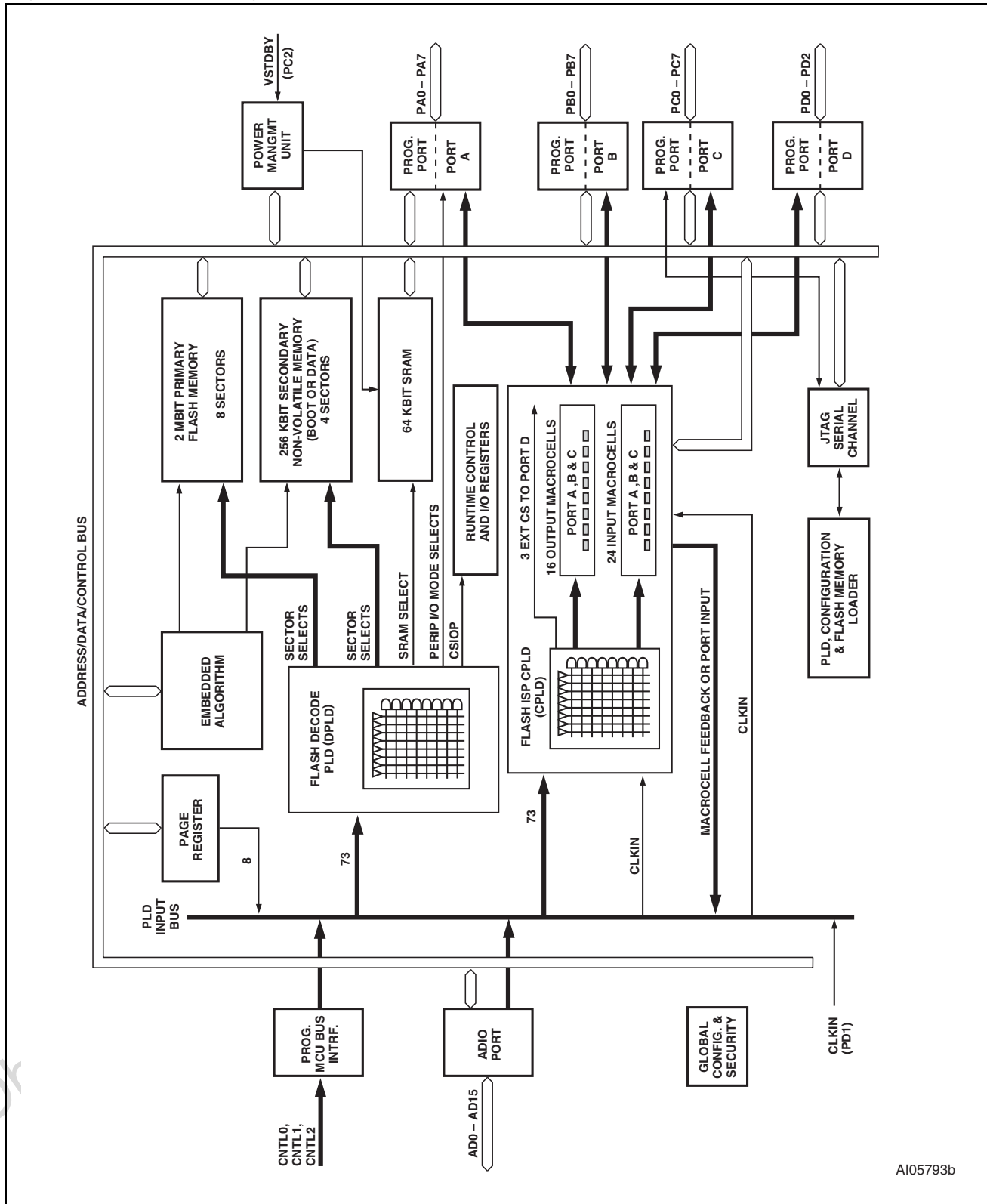

AI05793b

PSD ARCHITECTURAL OVERVIEW

PSD devices contain several major functional blocks. Figure 2 shows the architecture of the PSD device family. The functions of each block are described briefly in the following sections. Many of the blocks perform multiple functions and are user configurable.

Memory

Each of the memory blocks is briefly discussed in the following paragraphs. A more detailed discussion can be found in the section entitled “MEMORY BLOCKS” on page 15.

The 2 Mbit (256K x 8) Flash memory is the primary memory of the PSD. It is divided into 8 equally-sized sectors that are individually selectable.

The 256 Kbit (32K x 8) secondary Flash memory is divided into 4 equally-sized sectors. Each sector is individually selectable.

The 64 Kbit SRAM is intended for use as a scratch-pad memory or as an extension to the MCU SRAM.

Each sector of memory can be located in a different address space as defined by the user. The access times for all memory types includes the address latching and DPLD decoding time.

Page Register

The 8-bit Page Register expands the address range of the MCU by up to 256 times. The paged address can be used as part of the address space to access external memory and peripherals, or internal memory and I/O. The Page Register can also be used to change the address mapping of sectors of the Flash memories into different memory spaces for IAP.

PLDs

The device contains two PLDs, the Decode PLD (DPLD) and the Complex PLD (CPLD), as shown in Table 1, each optimized for a different function. The functional partitioning of the PLDs reduces power consumption, optimizes cost/performance, and eases design entry.

Table 1. PLD I/O

Name	Inputs	Outputs	Product Terms
Decode PLD (DPLD)	73	17	42
Complex PLD (CPLD)	73	19	140

The DPLD is used to decode addresses and to generate Sector Select signals for the PSD internal memory and registers. The DPLD has combinatorial outputs. The CPLD has 16 Output Macrocells (OMC) and 3 combinatorial outputs. The PSD also has 24 Input Macrocells (IMC) that can be configured as inputs to the PLDs. The PLDs receive their inputs from the PLD Input Bus and are differentiated by their output destinations, number of product terms, and macrocells.

The PLDs consume minimal power. The speed and power consumption of the PLD is controlled by the Turbo Bit in PMMR0 and other bits in the PMMR2. These registers are set by the MCU at run-time. There is a slight penalty to PLD propagation time when invoking the power management features.

I/O Ports

The PSD has 27 individually configurable I/O pins distributed over the four ports (Port A, B, C, and D). Each I/O pin can be individually configured for different functions. Ports can be configured as standard MCU I/O ports, PLD I/O, or latched address outputs for MCUs using multiplexed address/data buses.

The JTAG pins can be enabled on Port C for In-System Programming (ISP).

Ports A and B can also be configured as a data port for a non-multiplexed bus.

MCU Bus Interface

PSD interfaces easily with most 8-bit MCUs that have either multiplexed or non-multiplexed address/data buses. The device is configured to respond to the MCU's control signals, which are also used as inputs to the PLDs. For examples, please see the section entitled “MCU Bus Interface Examples” on page 41.

JTAG Port

In-System Programming (ISP) can be performed through the JTAG signals on Port C. This serial interface allows complete programming of the entire PSD device. A blank device can be completely programmed. The JTAG signals (TMS, TCK, TSTAT, TERR, TDI, TDO) can be multiplexed with other functions on Port C. Table 2 indicates the JTAG pin assignments.

In-System Programming (ISP)

Using the JTAG signals on Port C, the entire PSD device can be programmed or erased without the use of the MCU. The primary Flash memory can also be programmed in-system by the MCU executing the programming algorithms out of the secondary memory, or SRAM. The secondary memory can be programmed the same way by executing out of the primary Flash memory. The PLD or other PSD Configuration blocks can be programmed through the JTAG port or a device programmer. Table 3 indicates which programming methods can program different functional blocks of the PSD.

Power Management Unit (PMU)

The Power Management Unit (PMU) gives the user control of the power consumption on selected functional blocks based on system requirements. The PMU includes an Automatic Power-down

(APD) Unit that turns off device functions during MCU inactivity. The APD Unit has a Power-down mode that helps reduce power consumption.

The PSD also has some bits that are configured at run-time by the MCU to reduce power consumption of the CPLD. The Turbo Bit in PMMR0 can be reset to '0' and the CPLD latches its outputs and goes to sleep until the next transition on its inputs.

Additionally, bits in PMMR2 can be set by the MCU to block signals from entering the CPLD to reduce power consumption. Please see the section entitled "POWER MANAGEMENT" on page 56 for more details.

Table 2. JTAG Signals on Port C

Port C Pins	JTAG Signal
PC0	TMS
PC1	TCK
PC3	$\overline{\text{TSTAT}}$
PC4	$\overline{\text{TERR}}$
PC5	TDI
PC6	TDO

Table 3. Methods of Programming Different Functional Blocks of the PSD

Functional Block	JTAG Programming	Device Programmer	IAP
Primary Flash Memory	Yes	Yes	Yes
Secondary Flash Memory	Yes	Yes	Yes
PLD Array (DPLD and CPLD)	Yes	Yes	No
PSD Configuration	Yes	Yes	No

DEVELOPMENT SYSTEM

The PSD family is supported by PSDsoft Express, a Windows-based software development tool. A PSD design is quickly and easily produced in a point and click environment. The designer does not need to enter Hardware Description Language (HDL) equations, unless desired, to define PSD pin functions and memory map information. The general design flow is shown in Figure 3. PSDsoft Express is available from our web site (the ad-

dress is given on the back page of this data sheet) or other distribution channels.

PSDsoft Express directly supports two low cost device programmers from ST: PSDpro and FlashLINK (JTAG). Both of these programmers may be purchased through your local distributor/representative, or directly from our web site using a credit card. The PSD is also supported by third party device programmers. See our web site for the current list.

Figure 3. PSDsoft Express Development Tool

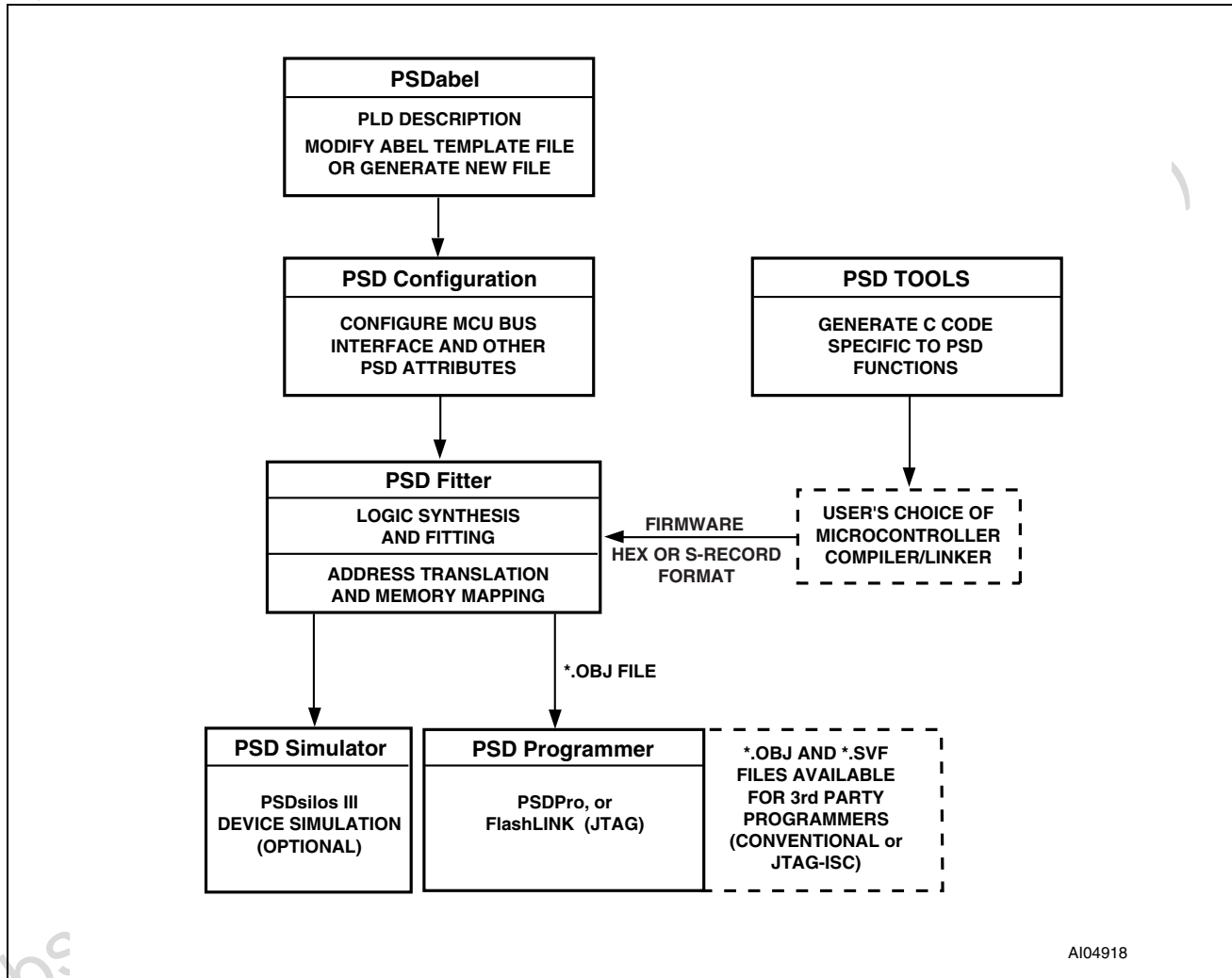

AI04918

PIN DESCRIPTION

Table 4 describes the signal names and signal functions of the PSD.

Table 4. Pin Description (for the PLCC52 package - Note 1)

Pin Name	Pin	Type	Description
ADIO0-7	30-37	I/O	This is the lower Address/Data port. Connect your MCU address or address/data bus according to the following rules: 1. If your MCU has a multiplexed address/data bus where the data is multiplexed with the lower address bits, connect AD0-AD7 to this port. 2. If your MCU does not have a multiplexed address/data bus, or you are using an 80C251 in page mode, connect A0-A7 to this port. 3. If you are using an 80C51XA in burst mode, connect A4/D0 through A11/D7 to this port. ALE or AS latches the address. The PSD drives data out only if the READ signal is active and one of the PSD functional blocks was selected. The addresses on this port are passed to the PLDs.
ADIO8-15	39-46	I/O	This is the upper Address/Data port. Connect your MCU address or address/data bus according to the following rules: 1. If your MCU has a multiplexed address/data bus where the data is multiplexed with the lower address bits, connect A8-A15 to this port. 2. If your MCU does not have a multiplexed address/data bus, connect A8-A15 to this port. 3. If you are using an 80C251 in page mode, connect AD8-AD15 to this port. 4. If you are using an 80C51XA in burst mode, connect A12/D8 through A19/D15 to this port. ALE or AS latches the address. The PSD drives data out only if the READ signal is active and one of the PSD functional blocks was selected. The addresses on this port are passed to the PLDs.
CNTL0	47	I	The following control signals can be connected to this port, based on your MCU: 1. \overline{WR} – active Low Write Strobe input. 2. R_W – active High READ/active Low WRITE input. This port is connected to the PLDs. Therefore, these signals can be used in decode and other logic equations.
CNTL1	50	I	The following control signals can be connected to this port, based on your MCU: 1. \overline{RD} – active Low Read Strobe input. 2. E – E clock input. 3. \overline{DS} – active Low Data Strobe input. 4. \overline{PSEN} – connect \overline{PSEN} to this port when it is being used as an active Low READ signal. For example, when the 80C251 outputs more than 16 address bits, \overline{PSEN} is actually the READ signal. This port is connected to the PLDs. Therefore, these signals can be used in decode and other logic equations.
CNTL2	49	I	This port can be used to input the \overline{PSEN} (Program Select Enable) signal from any MCU that uses this signal for code exclusively. If your MCU does not output a Program Select Enable signal, this port can be used as a generic input. This port is connected to the PLDs.
\overline{Reset}	48	I	Resets I/O Ports, PLD macrocells and some of the Configuration Registers. Must be Low at Power-up.

Pin Name	Pin	Type	Description
PA0 PA1 PA2 PA3 PA4 PA5 PA6 PA7	29 28 27 25 24 23 22 21	I/O	<p>These pins make up Port A. These port pins are configurable and can have the following functions:</p> <ol style="list-style-type: none"> 1. MCU I/O – write to or read from a standard output or input port. 2. CPLD macrocell (McellAB0-7) outputs. 3. Inputs to the PLDs. 4. Latched address outputs (see Table 5). 5. Address inputs. For example, PA0-3 could be used for A0-A3 when using an 80C51XA in burst mode. 6. As the data bus inputs D0-D7 for non-multiplexed address/data bus MCUs. 7. D0/A16-D3/A19 in M37702M2 mode. 8. Peripheral I/O mode. <p>Note: PA0-PA3 can only output CMOS signals with an option for high slew rate. However, PA4-PA7 can be configured as CMOS or Open Drain Outputs.</p>
PB0 PB1 PB2 PB3 PB4 PB5 PB6 PB7	7 6 5 4 3 2 52 51	I/O	<p>These pins make up Port B. These port pins are configurable and can have the following functions:</p> <ol style="list-style-type: none"> 1. MCU I/O – write to or read from a standard output or input port. 2. CPLD macrocell (McellAB0-7 or McellBC0-7) outputs. 3. Inputs to the PLDs. 4. Latched address outputs (see Table 5). <p>Note: PB0-PB3 can only output CMOS signals with an option for high slew rate. However, PB4-PB7 can be configured as CMOS or Open Drain Outputs.</p>
PC0	20	I/O	<p>PC0 pin of Port C. This port pin can be configured to have the following functions:</p> <ol style="list-style-type: none"> 1. MCU I/O – write to or read from a standard output or input port. 2. CPLD macrocell (McellBC0) output. 3. Input to the PLDs. 4. TMS Input² for the JTAG Serial Interface. <p>This pin can be configured as a CMOS or Open Drain output.</p>
PC1	19	I/O	<p>PC1 pin of Port C. This port pin can be configured to have the following functions:</p> <ol style="list-style-type: none"> 1. MCU I/O – write to or read from a standard output or input port. 2. CPLD macrocell (McellBC1) output. 3. Input to the PLDs. 4. TCK Input² for the JTAG Serial Interface. <p>This pin can be configured as a CMOS or Open Drain output.</p>
PC2	18	I/O	<p>PC2 pin of Port C. This port pin can be configured to have the following functions:</p> <ol style="list-style-type: none"> 1. MCU I/O – write to or read from a standard output or input port. 2. CPLD macrocell (McellBC2) output. 3. Input to the PLDs. <p>This pin can be configured as a CMOS or Open Drain output.</p>
PC3	17	I/O	<p>PC3 pin of Port C. This port pin can be configured to have the following functions:</p> <ol style="list-style-type: none"> 1. MCU I/O – write to or read from a standard output or input port. 2. CPLD macrocell (McellBC3) output. 3. Input to the PLDs. 4. $\overline{\text{TSTAT}}$ output² for the JTAG Serial Interface. 5. Ready/Busy output for parallel In-System Programming (ISP). <p>This pin can be configured as a CMOS or Open Drain output.</p>
PC4	14	I/O	<p>PC4 pin of Port C. This port pin can be configured to have the following functions:</p> <ol style="list-style-type: none"> 1. MCU I/O – write to or read from a standard output or input port. 2. CPLD macrocell (McellBC4) output. 3. Input to the PLDs. 4. $\overline{\text{TERR}}$ output² for the JTAG Serial Interface. <p>This pin can be configured as a CMOS or Open Drain output.</p>

Pin Name	Pin	Type	Description
PC5	13	I/O	PC5 pin of Port C. This port pin can be configured to have the following functions: 1. MCU I/O – write to or read from a standard output or input port. 2. CPLD macrocell (McellBC5) output. 3. Input to the PLDs. 4. TDI input ² for the JTAG Serial Interface. This pin can be configured as a CMOS or Open Drain output.
PC6	12	I/O	PC6 pin of Port C. This port pin can be configured to have the following functions: 1. MCU I/O – write to or read from a standard output or input port. 2. CPLD macrocell (McellBC6) output. 3. Input to the PLDs. 4. TDO output ² for the JTAG Serial Interface. This pin can be configured as a CMOS or Open Drain output.
PC7	11	I/O	PC7 pin of Port C. This port pin can be configured to have the following functions: 1. MCU I/O – write to or read from a standard output or input port. 2. CPLD macrocell (McellBC7) output. 3. Input to the PLDs. 4. DBE – active Low Data Byte Enable input from 68HC912 type MCUs. This pin can be configured as a CMOS or Open Drain output.
PD0	10	I/O	PD0 pin of Port D. This port pin can be configured to have the following functions: 1. ALE/AS input latches address output from the MCU. 2. MCU I/O – write or read from a standard output or input port. 3. Input to the PLDs. 4. CPLD output (External Chip Select).
PD1	9	I/O	PD1 pin of Port D. This port pin can be configured to have the following functions: 1. MCU I/O – write to or read from a standard output or input port. 2. Input to the PLDs. 3. CPLD output (External Chip Select). 4. CLKIN – clock input to the CPLD macrocells, the APD Unit's Power-down counter, and the CPLD AND Array.
PD2	8	I/O	PD2 pin of Port D. This port pin can be configured to have the following functions: 1. MCU I/O – write to or read from a standard output or input port. 2. Input to the PLDs. 3. CPLD output (External Chip Select). 4. PSD Chip Select Input (\overline{CS}). When Low, the MCU can access the PSD memory and I/O. When High, the PSD memory blocks are disabled to conserve power.
VCC	15, 38		Supply Voltage
GND	1, 16, 26		Ground pins

Note: 1. The pin numbers in this table are for the PLCC package only. See the package information, on page 90 onwards, for pin numbers on other package types.

2. These functions can be multiplexed with other functions.

PSD REGISTER DESCRIPTION AND ADDRESS OFFSET

Table 6 shows the offset addresses to the PSD registers relative to the CSIOP base address. The CSIOP space is the 256 bytes of address that is allocated by the user to the internal PSD registers.

Table 6 provides brief descriptions of the registers in CSIOP space. The following section gives a more detailed description.

Table 5. I/O Port Latched Address Output Assignments (Note 1)

MCU	Port A		Port B	
	Port A (3:0)	Port A (7:4)	Port B (3:0)	Port B (7:4)
8051XA (8-bit)	N/A	Address a7-a4	Address a11-a8	N/A
80C251 (page mode)	N/A	N/A	Address a11-a8	Address a15-a12
All other 8-bit multiplexed	Address a3-a0	Address a7-a4	Address a3-a0	Address a7-a4
8-bit non-multiplexed bus	N/A	N/A	Address a3-a0	Address a7-a4

Note: 1. See the section entitled "I/O PORTS", on page 46, on how to enable the Latched Address Output function.
 2. N/A = Not Applicable

Table 6. Register Address Offset

Register Name	Port A	Port B	Port C	Port D	Other ¹	Description
Data In	00	01	10	11		Reads Port pin as input, MCU I/O input mode
Control	02	03				Selects mode between MCU I/O or Address Out
Data Out	04	05	12	13		Stores data for output to Port pins, MCU I/O output mode
Direction	06	07	14	15		Configures Port pin as input or output
Drive Select	08	09	16	17		Configures Port pins as either CMOS or Open Drain on some pins, while selecting high slew rate on other pins.
Input Macrocell	0A	0B	18			Reads Input Macrocells
Enable Out	0C	0D	1A	1B		Reads the status of the output enable to the I/O Port driver
Output Macrocells AB	20	20				READ – reads output of macrocells AB WRITE – loads macrocell flip-flops
Output Macrocells BC		21	21			READ – reads output of macrocells BC WRITE – loads macrocell flip-flops
Mask Macrocells AB	22	22				Blocks writing to the Output Macrocells AB
Mask Macrocells BC		23	23			Blocks writing to the Output Macrocells BC
Primary Flash Protection					C0	Read only – Primary Flash Sector Protection
Secondary Flash memory Protection					C2	Read only – PSD Security and Secondary Flash memory Sector Protection
JTAG Enable					C7	Enables JTAG Port
PMMR0					B0	Power Management Register 0
PMMR2					B4	Power Management Register 2
Page					E0	Page Register
VM					E2	Places PSD memory areas in Program and/or Data space on an individual basis.

Note: 1. Other registers that are not part of the I/O ports.

DETAILED OPERATION

As shown in Figure 2, the PSD consists of six major types of functional blocks:

- Memory Blocks
- PLD Blocks
- MCU Bus Interface
- I/O Ports
- Power Management Unit (PMU)
- JTAG Interface

The functions of each block are described in the following sections. Many of the blocks perform multiple functions, and are user configurable.

MEMORY BLOCKS

The PSD has the following memory blocks:

- Primary Flash memory
- Secondary Flash memory
- SRAM

The Memory Select signals for these blocks originate from the Decode PLD (DPLD) and are user-defined in PSDsoft Express.

Primary Flash Memory and Secondary Flash memory Description

The primary Flash memory is divided evenly into eight equal sectors. The secondary Flash memory is divided into four equal sectors. Each sector of either memory block can be separately protected from Program and Erase cycles.

Flash memory may be erased on a sector-by-sector basis. Flash sector erasure may be suspended while data is read from other sectors of the block and then resumed after reading.

During a Program or Erase cycle in Flash memory, the status can be output on Ready/Busy (PC3). This pin is set up using PSDsoft Express Configuration.

Memory Block Select Signals

The DPLD generates the Select signals for all the internal memory blocks (see the section entitled "PLDS", on page 27). Each of the eight sectors of

the primary Flash memory has a Select signal (FS0-FS7) which can contain up to three product terms. Each of the four sectors of the secondary Flash memory has a Select signal (CSBOOT0-CSBOOT3) which can contain up to three product terms. Having three product terms for each Select signal allows a given sector to be mapped in different areas of system memory. When using a MCU with separate Program and Data space, these flexible Select signals allow dynamic re-mapping of sectors from one memory space to the other.

Ready/Busy (PC3). This signal can be used to output the Ready/Busy status of the PSD. The output on Ready/Busy (PC3) is a 0 (Busy) when Flash memory is being written to, or when Flash memory is being erased. The output is a 1 (Ready) when no WRITE or Erase cycle is in progress.

Memory Operation. The primary Flash memory and secondary Flash memory are addressed through the MCU Bus Interface. The MCU can access these memories in one of two ways:

- The MCU can execute a typical bus WRITE or READ *operation* just as it would if accessing a RAM or ROM device using standard bus cycles.
- The MCU can execute a specific instruction that consists of several WRITE and READ operations. This involves writing specific data patterns to special addresses within the Flash memory to invoke an embedded algorithm. These instructions are summarized in Table 7.

Typically, the MCU can read Flash memory using READ operations, just as it would read a ROM device. However, Flash memory can only be altered using specific Erase and Program instructions. For example, the MCU cannot write a single byte directly to Flash memory as it would write a byte to RAM. To program a byte into Flash memory, the MCU must execute a Program instruction, then test the status of the Program cycle. This status test is achieved by a READ operation or polling Ready/Busy (PC3).

Flash memory can also be read by using special instructions to retrieve particular Flash device information (sector protect status and ID).

Table 7. Instructions

Instruction	FS0-FS7 or CSBOOT0-CSBOOT3	Cycle 1	Cycle 2	Cycle 3	Cycle 4	Cycle 5	Cycle 6	Cycle 7
READ ⁵	1	"Read" RD @ RA						
Read Main Flash ID ⁶	1	AAh@ X555h	55h@ XAAAh	90h@ X555h	Read identifier (A6,A1,A0 = 0,0,1)			
Read Sector Protection ^{6,8,13}	1	AAh@ X555h	55h@ XAAAh	90h@ X555h	Read identifier (A6,A1,A0 = 0,1,0)			
Program a Flash Byte ¹³	1	AAh@ X555h	55h@ XAAAh	A0h@ X555h	PD@ PA			
Flash Sector Erase ^{7,13}	1	AAh@ X555h	55h@ XAAAh	80h@ X555h	AAh@ XAAAh	55h@ XAAAh	30h@ SA	30h ⁷ @ next SA
Flash Bulk Erase ¹³	1	AAh@ X555h	55h@ XAAAh	80h@ X555h	AAh@ XAAAh	55h@ XAAAh	10h@ X555h	
Suspend Sector Erase ¹¹	1	B0h@ XXXXh						
Resume Sector Erase ¹²	1	30h@ XXXXh						
Reset ⁶	1	F0h@ XXXXh						
Unlock Bypass	1	AAh@ X555h	55h@ XAAAh	20h@ X555h				
Unlock Bypass Program ⁹	1	A0h@ XXXXh	PD@ PA					
Unlock Bypass Reset ¹⁰	1	90h@ XXXXh	00h@ XXXXh					

Note: 1. All bus cycles are WRITE bus cycles, except the ones with the "Read" label

2. All values are in hexadecimal:

X = Don't Care. Addresses of the form XXXXh, in this table, must be even addresses

RA = Address of the memory location to be read

RD = Data read from location RA during the READ cycle

PA = Address of the memory location to be programmed. Addresses are latched on the falling edge of Write Strobe (\overline{WR} , CNTL0).

PA is an even address for PSD in word programming mode.

PD = Data word to be programmed at location PA. Data is latched on the rising edge of Write Strobe (\overline{WR} , CNTL0)

SA = Address of the sector to be erased or verified. The Sector Select (FS0-FS7 or CSBOOT0-CSBOOT3) of the sector to be erased, or verified, must be Active (High).

3. Sector Select (FS0 to FS7 or CSBOOT0 to CSBOOT3) signals are active High, and are defined in PSDsoft Express.

4. Only address bits A11-A0 are used in instruction decoding.

5. No Unlock or instruction cycles are required when the device is in the READ Mode

6. The Reset instruction is required to return to the READ Mode after reading the Flash ID, or after reading the Sector Protection Status, or if the Error Flag (DQ5/DQ13) Bit goes High.

7. Additional sectors to be erased must be written at the end of the Sector Erase instruction within 80 μ s.

8. The data is 00h for an unprotected sector, and 01h for a protected sector. In the fourth cycle, the Sector Select is active, and (A1,A0)=(1,0)

9. The Unlock Bypass instruction is required prior to the Unlock Bypass Program instruction.

10. The Unlock Bypass Reset Flash instruction is required to return to reading memory data when the device is in the Unlock Bypass mode.

11. The system may perform Read and Program cycles in non-erasing sectors, read the Flash ID or read the Sector Protection Status when in the Suspend Sector Erase mode. The Suspend Sector Erase instruction is valid only during a Sector Erase cycle.

12. The Resume Sector Erase instruction is valid only during the Suspend Sector Erase mode.

13. The MCU cannot invoke these instructions while executing code from the same Flash memory as that for which the instruction is intended. The MCU must fetch, for example, the code from the secondary Flash memory when reading the Sector Protection Status of the primary Flash memory.

INSTRUCTIONS

An instruction consists of a sequence of specific operations. Each received byte is sequentially decoded by the PSD and not executed as a standard WRITE operation. The instruction is executed when the correct number of bytes are properly received and the time between two consecutive bytes is shorter than the time-out period. Some instructions are structured to include READ operations after the initial WRITE operations.

The instruction must be followed exactly. Any invalid combination of instruction bytes or time-out between two consecutive bytes while addressing Flash memory resets the device logic into READ Mode (Flash memory is read like a ROM device).

The PSD supports the instructions summarized in Table 7:

Flash memory:

- Erase memory by chip or sector
- Suspend or resume sector erase
- Program a Byte
- Reset to READ Mode
- Read primary Flash Identifier value
- Read Sector Protection Status
- Bypass

These instructions are detailed in Table 7. For efficient decoding of the instructions, the first two bytes of an instruction are the coded cycles and are followed by an instruction byte or confirmation byte. The coded cycles consist of writing the data AAh to address X555h during the first cycle and data 55h to address XAAAh during the second cycle. Address signals A15-A12 are Don't Care during the instruction WRITE cycles. However, the appropriate Sector Select (FS0-FS7 or CSBOOT0-CSBOOT3) must be selected.

The primary and secondary Flash memories have the same instruction set (except for Read Primary Flash Identifier). The Sector Select signals determine which Flash memory is to receive and execute the instruction. The primary Flash memory is selected if any one of Sector Select (FS0-FS7) is High, and the secondary Flash memory is selected if any one of Sector Select (CSBOOT0-CSBOOT3) is High.

Power-down Instruction and Power-up Mode

Power-up Mode. The PSD internal logic is reset upon Power-up to the READ Mode. Sector Select (FS0-FS7 and CSBOOT0-CSBOOT3) must be

held Low, and Write Strobe (\overline{WR} , CNTL0) High, during Power-up for maximum security of the data contents and to remove the possibility of a byte being written on the first edge of Write Strobe (WR, CNTL0). Any WRITE cycle initiation is locked when V_{CC} is below V_{LKO} .

READ

Under typical conditions, the MCU may read the primary Flash memory or the secondary Flash memory using READ operations just as it would a ROM or RAM device. Alternately, the MCU may use READ operations to obtain status information about a Program or Erase cycle that is currently in progress. Lastly, the MCU may use instructions to read special data from these memory blocks. The following sections describe these READ functions.

Read Memory Contents. Primary Flash memory and secondary Flash memory are placed in the READ Mode after Power-up, chip reset, or a Reset Flash instruction (see Table 7). The MCU can read the memory contents of the primary Flash memory or the secondary Flash memory by using READ operations any time the READ operation is not part of an instruction.

Read Primary Flash Identifier. The primary Flash memory identifier is read with an instruction composed of 4 operations: 3 specific WRITE operations and a READ operation (see Table 7). During the READ operation, address Bits A6, A1, and A0 must be '0,' '0,' and '1,' respectively, and the appropriate Sector Select (FS0-FS7) must be High. The identifier for the device is E7h.

Read Memory Sector Protection Status. The primary Flash memory Sector Protection Status is read with an instruction composed of 4 operations: 3 specific WRITE operations and a READ operation (see Table 7). During the READ operation, address Bits A6, A1, and A0 must be '0,' '1,' and '0,' respectively, while Sector Select (FS0-FS7 or CSBOOT0-CSBOOT3) designates the Flash memory sector whose protection has to be verified. The READ operation produces 01h if the Flash memory sector is protected, or 00h if the sector is not protected.

The sector protection status for all NVM blocks (primary Flash memory or secondary Flash memory) can also be read by the MCU accessing the Flash Protection registers in PSD I/O space. See the section entitled "Flash Memory Sector Protection", on page 22, for register definitions.

Reading the Erase/Program Status Bits. The PSD provides several status bits to be used by the MCU to confirm the completion of an Erase or Program cycle of Flash memory. These status bits minimize the time that the MCU spends performing these tasks and are defined in Table 8. The status bits can be read as many times as needed. For Flash memory, the MCU can perform a READ operation to obtain these status bits while an Erase or Program instruction is being executed by the embedded algorithm. See the section entitled “Programming Flash Memory”, on page 19, for details.

Data Polling Flag (DQ7). When erasing or programming in Flash memory, the Data Polling Flag (DQ7) Bit outputs the complement of the bit being entered for programming/writing on the DQ7 Bit. Once the Program instruction or the WRITE operation is completed, the true logic value is read on the Data Polling Flag (DQ7) Bit (in a READ operation).

- Data Polling is effective after the fourth WRITE pulse (for a Program instruction) or after the sixth WRITE pulse (for an Erase instruction). It must be performed at the address being programmed or at an address within the Flash memory sector being erased.
- During an Erase cycle, the Data Polling Flag (DQ7) Bit outputs a '0.' After completion of the cycle, the Data Polling Flag (DQ7) Bit outputs the last bit programmed (it is a '1' after erasing).
- If the byte to be programmed is in a protected Flash memory sector, the instruction is ignored.
- If all the Flash memory sectors to be erased are protected, the Data Polling Flag (DQ7) Bit is reset to '0' for about 100µs, and then returns to the previous addressed byte. No erasure is performed.

Toggle Flag (DQ6). The PSD offers another way for determining when the Flash memory Program cycle is completed. During the internal WRITE operation and when either the FS0-FS7 or CSBOOT0-CSBOOT3 is true, the Toggle Flag (DQ6) Bit toggles from '0' to '1' and '1' to '0' on subsequent attempts to read any byte of the memory.

When the internal cycle is complete, the toggling stops and the data READ on the Data Bus D0-D7 is the addressed memory byte. The device is now accessible for a new READ or WRITE operation. The cycle is finished when two successive READs yield the same output data.

- The Toggle Flag (DQ6) Bit is effective after the fourth WRITE pulse (for a Program instruction) or after the sixth WRITE pulse (for an Erase instruction).
- If the byte to be programmed belongs to a protected Flash memory sector, the instruction is ignored.
- If all the Flash memory sectors selected for erasure are protected, the Toggle Flag (DQ6) Bit toggles to '0' for about 100µs and then returns to the previous addressed byte.

Error Flag (DQ5). During a normal Program or Erase cycle, the Error Flag (DQ5) Bit is to '0.' This bit is set to '1' when there is a failure during Flash memory Byte Program, Sector Erase, or Bulk Erase cycle.

In the case of Flash memory programming, the Error Flag (DQ5) Bit indicates the attempt to program a Flash memory bit from the programmed state, '0,' to the erased state, '1,' which is not valid. The Error Flag (DQ5) Bit may also indicate a Time-out condition while attempting to program a byte.

In case of an error in a Flash memory Sector Erase or Byte Program cycle, the Flash memory sector in which the error occurred or to which the programmed byte belongs must no longer be used. Other Flash memory sectors may still be used. The Error Flag (DQ5) Bit is reset after a Reset Flash instruction.

Erase Time-out Flag (DQ3). The Erase Time-out Flag (DQ3) Bit reflects the time-out period allowed between two consecutive Sector Erase instructions. The Erase Time-out Flag (DQ3) Bit is reset to '0' after a Sector Erase cycle for a time period of 100µs + 20% unless an additional Sector Erase instruction is decoded. After this time period, or when the additional Sector Erase instruction is decoded, the Erase Time-out Flag (DQ3) Bit is set to '1.'

Table 8. Status Bit

Functional Block	FS0-FS7/CSBOOT0-CSBOOT3	DQ7	DQ6	DQ5	DQ4	DQ3	DQ2	DQ1	DQ0
Flash Memory	V _{IH}	Data Polling	Toggle Flag	Error Flag	X	Erase Time-out	X	X	X

Note: 1. X = Not guaranteed value, can be read either 1 or 0.
 2. DQ7-DQ0 represent the Data Bus Bits, D7-D0.
 3. FS0-FS7 and CSBOOT0-CSBOOT3 are active High.



Programming Flash Memory

Flash memory must be erased prior to being programmed. A byte of Flash memory is erased to all 1s (FFh), and is programmed by setting selected bits to '0.' The MCU may erase Flash memory all at once or by-sector, but not byte-by-byte. However, the MCU may program Flash memory byte-by-byte.

The primary and secondary Flash memories require the MCU to send an instruction to program a byte or to erase sectors (see Table 7).

Once the MCU issues a Flash memory Program or Erase instruction, it must check for the status bits for completion. The embedded algorithms that are invoked inside the PSD support several means to provide status to the MCU. Status may be checked using any of three methods: Data Polling, Data Toggle, or Ready/Busy (PC3).

Data Polling. Polling on the Data Polling Flag (DQ7) Bit is a method of checking whether a Program or Erase cycle is in progress or has completed. Figure 4 shows the Data Polling algorithm.

When the MCU issues a Program instruction, the embedded algorithm within the PSD begins. The MCU then reads the location of the byte to be programmed in Flash memory to check status. The Data Polling Flag (DQ7) Bit of this location becomes the complement of b7 of the original data byte to be programmed. The MCU continues to poll this location, comparing the Data Polling Flag (DQ7) Bit and monitoring the Error Flag (DQ5) Bit. When the Data Polling Flag (DQ7) Bit matches b7 of the original data, and the Error Flag (DQ5) Bit remains '0,' the embedded algorithm is complete. If the Error Flag (DQ5) Bit is '1,' the MCU should test the Data Polling Flag (DQ7) Bit again since the Data Polling Flag (DQ7) Bit may have changed simultaneously with the Error Flag (DQ5) Bit (see Figure 4).

The Error Flag (DQ5) Bit is set if either an internal time-out occurred while the embedded algorithm attempted to program the byte or if the MCU attempted to program a '1' to a bit that was not erased (not erased is logic 0).

It is suggested (as with all Flash memories) to read the location again after the embedded program-

ming algorithm has completed, to compare the byte that was written to the Flash memory with the byte that was intended to be written.

When using the Data Polling method during an Erase cycle, Figure 4 still applies. However, the Data Polling Flag (DQ7) Bit is '0' until the Erase cycle is complete. A '1' on the Error Flag (DQ5) Bit indicates a time-out condition on the Erase cycle; a '0' indicates no error. The MCU can read any location within the sector being erased to get the Data Polling Flag (DQ7) Bit and the Error Flag (DQ5) Bit.

PSDsoft Express generates ANSI C code functions which implement these Data Polling algorithms.

Figure 4. Data Polling Flowchart

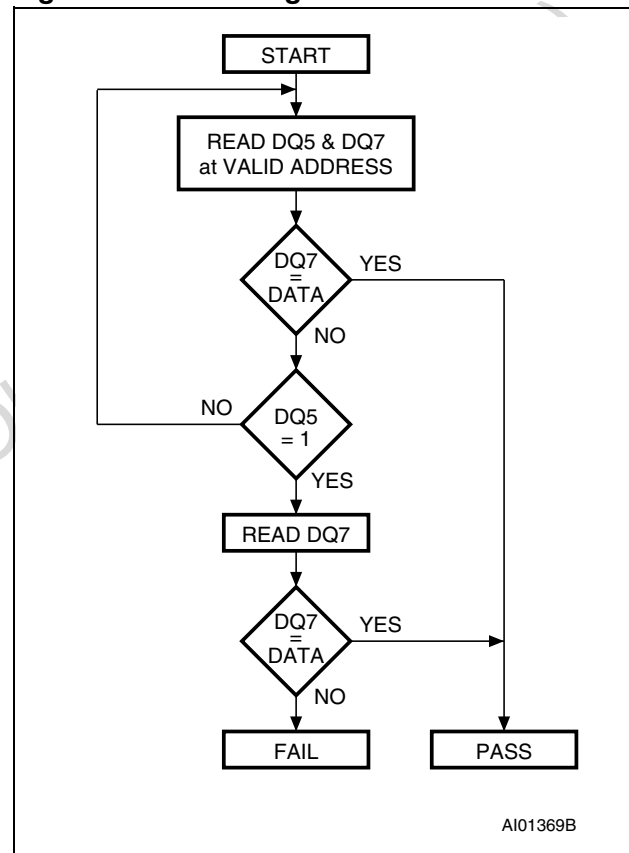

Data Toggle. Checking the Toggle Flag (DQ6) Bit is a method of determining whether a Program or Erase cycle is in progress or has completed. Figure 5 shows the Data Toggle algorithm.

When the MCU issues a Program instruction, the embedded algorithm within the PSD begins. The MCU then reads the location of the byte to be programmed in Flash memory to check status. The Toggle Flag (DQ6) Bit of this location toggles each time the MCU reads this location until the embedded algorithm is complete. The MCU continues to read this location, checking the Toggle Flag (DQ6) Bit and monitoring the Error Flag (DQ5) Bit. When the Toggle Flag (DQ6) Bit stops toggling (two consecutive READs yield the same value), and the Error Flag (DQ5) Bit remains '0,' the embedded algorithm is complete. If the Error Flag (DQ5) Bit is '1,' the MCU should test the Toggle Flag (DQ6) Bit again, since the Toggle Flag (DQ6) Bit may have changed simultaneously with the Error Flag (DQ5) Bit (see Figure 5).

Figure 5. Data Toggle Flowchart

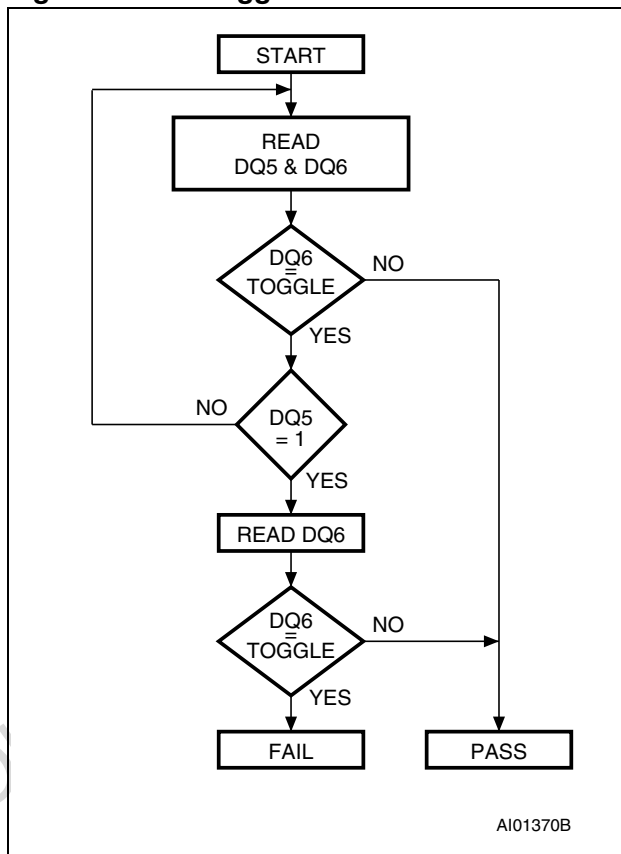

The Error Flag (DQ5) Bit is set if either an internal time-out occurred while the embedded algorithm attempted to program the byte, or if the MCU attempted to program a '1' to a bit that was not erased (not erased is logic '0').

It is suggested (as with all Flash memories) to read the location again after the embedded programming algorithm has completed, to compare the byte that was written to Flash memory with the byte that was intended to be written.

When using the Data Toggle method after an Erase cycle, Figure 5 still applies. the Toggle Flag (DQ6) Bit toggles until the Erase cycle is complete. A 1 on the Error Flag (DQ5) Bit indicates a time-out condition on the Erase cycle; a 0 indicates no error. The MCU can read any location within the sector being erased to get the Toggle Flag (DQ6) Bit and the Error Flag (DQ5) Bit.

PSDsoft Express generates ANSI C code functions which implement these Data Toggling algorithms.

Unlock Bypass. The Unlock Bypass instructions allow the system to program bytes to the Flash memories faster than using the standard Program instruction. The Unlock Bypass mode is entered by first initiating two Unlock cycles. This is followed by a third WRITE cycle containing the Unlock Bypass code, 20h (as shown in Table 7).

The Flash memory then enters the Unlock Bypass mode. A two-cycle Unlock Bypass Program instruction is all that is required to program in this mode. The first cycle in this instruction contains the Unlock Bypass Program code, A0h. The second cycle contains the program address and data. Additional data is programmed in the same manner. These instructions dispense with the initial two Unlock cycles required in the standard Program instruction, resulting in faster total Flash memory programming.

During the Unlock Bypass mode, only the Unlock Bypass Program and Unlock Bypass Reset Flash instructions are valid.

To exit the Unlock Bypass mode, the system must issue the two-cycle Unlock Bypass Reset Flash instruction. The first cycle must contain the data 90h; the second cycle the data 00h. Addresses are Don't Care for both cycles. The Flash memory then returns to READ Mode.

Erasing Flash Memory

Flash Bulk Erase. The Flash Bulk Erase instruction uses six WRITE operations followed by a READ operation of the status register, as described in Table 7. If any byte of the Bulk Erase instruction is wrong, the Bulk Erase instruction aborts and the device is reset to the Read Flash memory status.

During a Bulk Erase, the memory status may be checked by reading the Error Flag (DQ5) Bit, the Toggle Flag (DQ6) Bit, and the Data Polling Flag (DQ7) Bit, as detailed in the section entitled “Programming Flash Memory”, on page 19. The Error Flag (DQ5) Bit returns a '1' if there has been an Erase Failure (maximum number of Erase cycles have been executed).

It is not necessary to program the memory with 00h because the PSD automatically does this before erasing to 0FFh.

During execution of the Bulk Erase instruction, the Flash memory does not accept any instructions.

Flash Sector Erase. The Sector Erase instruction uses six WRITE operations, as described in Table 7. Additional Flash Sector Erase codes and Flash memory sector addresses can be written subsequently to erase other Flash memory sectors in parallel, without further coded cycles, if the additional bytes are transmitted in a shorter time than the time-out period of about 100µs. The input of a new Sector Erase code restarts the time-out period.

The status of the internal timer can be monitored through the level of the Erase Time-out Flag (DQ3) Bit. If the Erase Time-out Flag (DQ3) Bit is '0,' the Sector Erase instruction has been received and the time-out period is counting. If the Erase Time-out Flag (DQ3) Bit is '1,' the time-out period has expired and the PSD is busy erasing the Flash memory sector(s). Before and during Erase time-out, any instruction other than Suspend Sector Erase and Resume Sector Erase instructions abort the cycle that is currently in progress, and reset the device to READ Mode. It is not necessary to program the Flash memory sector with 00h as the PSD does this automatically before erasing (byte=FFh).

During a Sector Erase, the memory status may be checked by reading the Error Flag (DQ5) Bit, the Toggle Flag (DQ6) Bit, and the Data Polling Flag

(DQ7) Bit, as detailed in the section entitled “Programming Flash Memory”, on page 19.

During execution of the Erase cycle, the Flash memory accepts only Reset and Suspend Sector Erase instructions. Erasure of one Flash memory sector may be suspended, in order to read data from another Flash memory sector, and then resumed.

Suspend Sector Erase. When a Sector Erase cycle is in progress, the Suspend Sector Erase instruction can be used to suspend the cycle by writing 0B0h to any address when an appropriate Sector Select (FS0-FS7 or CSBOOT0-CSBOOT3) is High. (See Table 7). This allows reading of data from another Flash memory sector after the Erase cycle has been suspended. Suspend Sector Erase is accepted only during an Erase cycle and defaults to READ Mode. A Suspend Sector Erase instruction executed during an Erase time-out period, in addition to suspending the Erase cycle, terminates the time out period.

The Toggle Flag (DQ6) Bit stops toggling when the PSD internal logic is suspended. The status of this bit must be monitored at an address within the Flash memory sector being erased. The Toggle Flag (DQ6) Bit stops toggling between 0.1µs and 15µs after the Suspend Sector Erase instruction has been executed. The PSD is then automatically set to READ Mode.

If an Suspend Sector Erase instruction was executed, the following rules apply:

- Attempting to read from a Flash memory sector that was being erased outputs invalid data.
- Reading from a Flash sector that was *not* being erased is valid.
- The Flash memory *cannot* be programmed, and only responds to Resume Sector Erase and Reset Flash instructions (READ is an operation and is allowed).
- If a Reset Flash instruction is received, data in the Flash memory sector that was being erased is invalid.

Resume Sector Erase. If a Suspend Sector Erase instruction was previously executed, the erase cycle may be resumed with this instruction. The Resume Sector Erase instruction consists of writing 030h to any address while an appropriate Sector Select (FS0-FS7 or CSBOOT0-CSBOOT3) is High. (See Table 7.)

Specific Features

Flash Memory Sector Protect. Each primary and secondary Flash memory sector can be separately protected against Program and Erase cycles. Sector Protection provides additional data security because it disables all Program or Erase cycles. This mode can be activated through the JTAG Port or a Device Programmer.

Sector protection can be selected for each sector using the PSDsoft Express Configuration program. This automatically protects selected sectors when the device is programmed through the JTAG Port or a Device Programmer. Flash memory sectors can be unprotected to allow updating of their

contents using the JTAG Port or a Device Programmer. The MCU can read (but cannot change) the sector protection bits.

Any attempt to program or erase a protected Flash memory sector is ignored by the device. The Verify operation results in a READ of the protected data. This allows a guarantee of the retention of the Protection status.

The sector protection status can be read by the MCU through the Flash memory protection and PSD/EE protection registers (in the CSIOP block). See Table 9 and Table 10.

Table 9. Sector Protection/Security Bit Definition – Flash Protection Register

Bit 7	Bit 6	Bit 5	Bit 4	Bit 3	Bit 2	Bit 1	Bit 0
Sec7_Prot	Sec6_Prot	Sec5_Prot	Sec4_Prot	Sec3_Prot	Sec2_Prot	Sec1_Prot	Sec0_Prot

Note: 1. Bit Definitions:

Sec<i>_Prot 1 = Primary Flash memory or secondary Flash memory Sector <i> is write protected.

Sec<i>_Prot 0 = Primary Flash memory or secondary Flash memory Sector <i> is not write protected.

Table 10. Sector Protection/Security Bit Definition – PSD/EE Protection Register

Bit 7	Bit 6	Bit 5	Bit 4	Bit 3	Bit 2	Bit 1	Bit 0
Security_Bit	not used	not used	not used	Sec3_Prot	Sec2_Prot	Sec1_Prot	Sec0_Prot

Note: 1. Bit Definitions:

Sec<i>_Prot 1 = Secondary Flash memory Sector <i> is write protected.

Sec<i>_Prot 0 = Secondary Flash memory Sector <i> is not write protected.

Security_Bit 0 = Security Bit in device has not been set.

1 = Security Bit in device has been set.

Reset Flash. The Reset Flash instruction consists of one WRITE cycle (see Table 7). It can also be optionally preceded by the standard two WRITE decoding cycles (writing AAh to 555h and 55h to AAh). It must be executed after:

- Reading the Flash Protection Status or Flash ID
- An Error condition has occurred (and the device has set the Error Flag Bit (DQ5) to '1') during a Flash memory Program or Erase cycle.

The Reset Flash instruction puts the Flash memory back into normal READ Mode. If an Error condition has occurred (and the device has set the Error Flag Bit (DQ5) to '1') the Flash memory is put back into normal READ Mode within 25 μ s of the Reset Flash instruction having been issued. The Reset Flash instruction is ignored when it is issued dur-

ing a Program or Bulk Erase cycle of the Flash memory. The Reset Flash instruction aborts any on-going Sector Erase cycle, and returns the Flash memory to the normal READ Mode within 25 μ s.

Reset (RESET) Signal. A pulse on Reset ($\overline{\text{RESET}}$) aborts any cycle that is in progress, and resets the Flash memory to the READ Mode. When the reset occurs during a Program or Erase cycle, the Flash memory takes up to 25 μ s to return to the READ Mode. It is recommended that the Reset ($\overline{\text{RESET}}$) pulse (except for Power On Reset, as described on page 61) be at least 25 μ s so that the Flash memory is always ready for the MCU to fetch the bootstrap instructions after the Reset cycle is complete.

SRAM

The SRAM is enabled when SRAM Select (RS0) from the DPLD is High. SRAM Select (RS0) can contain up to two product terms, allowing flexible memory mapping.

SRAM Select (RS0) is configured using PSDsoft Express Configuration.

Sector Select and SRAM Select

Sector Select (FS0-FS7, CSBOOT0-CSBOOT3) and SRAM Select (RS0) are all outputs of the DPLD. They are setup by writing equations for them in PSDlabel. The following rules apply to the equations for these signals:

1. Primary Flash memory and secondary Flash memory Sector Select signals must *not* be larger than the physical sector size.
2. Any primary Flash memory sector must *not* be mapped in the same memory space as another Flash memory sector.
3. A secondary Flash memory sector must *not* be mapped in the same memory space as another secondary Flash memory sector.
4. SRAM, I/O, and Peripheral I/O spaces must *not* overlap.
5. A secondary Flash memory sector *may* overlap a primary Flash memory sector. In case of overlap, priority is given to the secondary Flash memory sector.
6. SRAM, I/O, and Peripheral I/O spaces *may* overlap any other memory sector. Priority is given to the SRAM, I/O, or Peripheral I/O.

Example. FS0 is valid when the address is in the range of 8000h to BFFFh, CSBOOT0 is valid from 8000h to 9FFFh, and RS0 is valid from 8000h to 87FFh. Any address in the range of RS0 always

accesses the SRAM. Any address in the range of CSBOOT0 greater than 87FFh (and less than 9FFFh) automatically addresses secondary Flash memory segment 0. Any address greater than 9FFFh accesses the primary Flash memory segment 0. You can see that half of the primary Flash memory segment 0 and one-fourth of secondary Flash memory segment 0 cannot be accessed in this example. Also note that an equation that defined FS1 to anywhere in the range of 8000h to BFFFh would *not* be valid.

Figure 6 shows the priority levels for all memory components. Any component on a higher level can overlap and has priority over any component on a lower level. Components on the same level must *not* overlap. Level one has the highest priority and level 3 has the lowest.

Figure 6. Priority Level of Memory and I/O Components

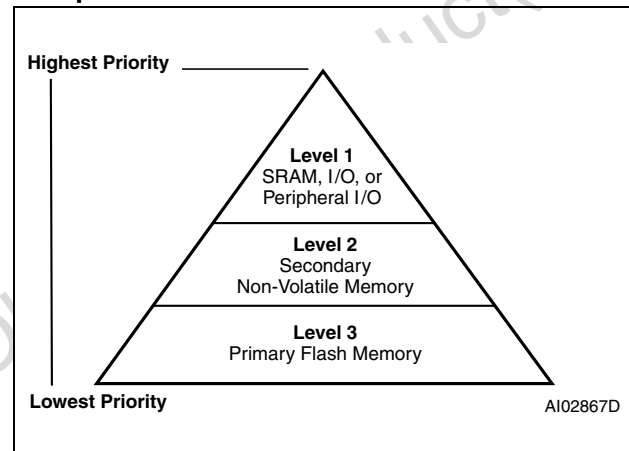

Memory Select Configuration for MCUs with Separate Program and Data Spaces. The 8031 and compatible family of MCUs, which includes the 80C51, 80C151, 80C251, and 80C51XA, have separate address spaces for Program memory (selected using Program Select Enable ($\overline{\text{PSEN}}$, CNTL2)) and Data memory (selected using Read Strobe ($\overline{\text{RD}}$, CNTL1)). Any of the memories within the PSD can reside in either space or both spaces. This is controlled through manipulation of the VM register that resides in the CSIOP space.

The VM register is set using PSDsoft Express to have an initial value. It can subsequently be

changed by the MCU so that memory mapping can be changed on-the-fly.

For example, you may wish to have SRAM and primary Flash memory in the Data space at Boot-up, and secondary Flash memory in the Program space at Boot-up, and later swap the primary and secondary Flash memories. This is easily done with the VM register by using PSDsoft Express Configuration to configure it for Boot-up and having the MCU change it when desired.

Table 11 describes the VM Register.

Table 11. VM Register

Bit 7 PIO_EN	Bit 6	Bit 5	Bit 4 Primary FL_Data	Bit 3 Secondary EE_Data	Bit 2 Primary FL_Code	Bit 1 Secondary EE_Code	Bit 0 SRAM_Code
0 = disable PIO mode	not used	not used	0 = $\overline{\text{RD}}$ can't access Flash memory	0 = $\overline{\text{RD}}$ can't access Secondary Flash memory	0 = $\overline{\text{PSEN}}$ can't access Flash memory	0 = $\overline{\text{PSEN}}$ can't access Secondary Flash memory	0 = $\overline{\text{PSEN}}$ can't access SRAM
1 = enable PIO mode	not used	not used	1 = $\overline{\text{RD}}$ access Flash memory	1 = $\overline{\text{RD}}$ access Secondary Flash memory	1 = $\overline{\text{PSEN}}$ access Flash memory	1 = $\overline{\text{PSEN}}$ access Secondary Flash memory	1 = $\overline{\text{PSEN}}$ access SRAM

Configuration Modes for MCUs with Separate Program and Data Spaces. Separate Space Modes. Program space is separated from Data space. For example, Program Select Enable ($\overline{\text{PSEN}}$, CNTL2) is used to access the program code

from the primary Flash memory, while Read Strobe ($\overline{\text{RD}}$, CNTL1) is used to access data from the secondary Flash memory, SRAM and I/O Port blocks. This configuration requires the VM register to be set to 0Ch (see Figure 7).

Figure 7. 8031 Memory Modules – Separate Space

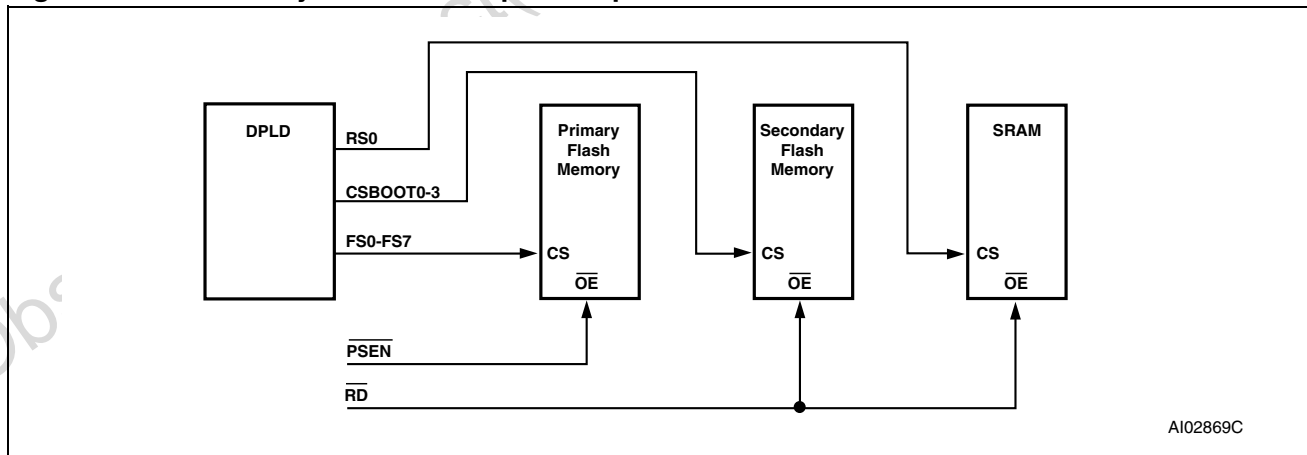

Combined Space Modes. The Program and Data spaces are combined into one memory space that allows the primary Flash memory, secondary Flash memory, and SRAM to be accessed by either Program Select Enable ($\overline{\text{PSEN}}$, CNTL2)

or Read Strobe ($\overline{\text{RD}}$, CNTL1). For example, to configure the primary Flash memory in Combined space, Bits b2 and b4 of the VM register are set to 1 (see Figure 8).

Figure 8. 8031 Memory Modules – Combined Space

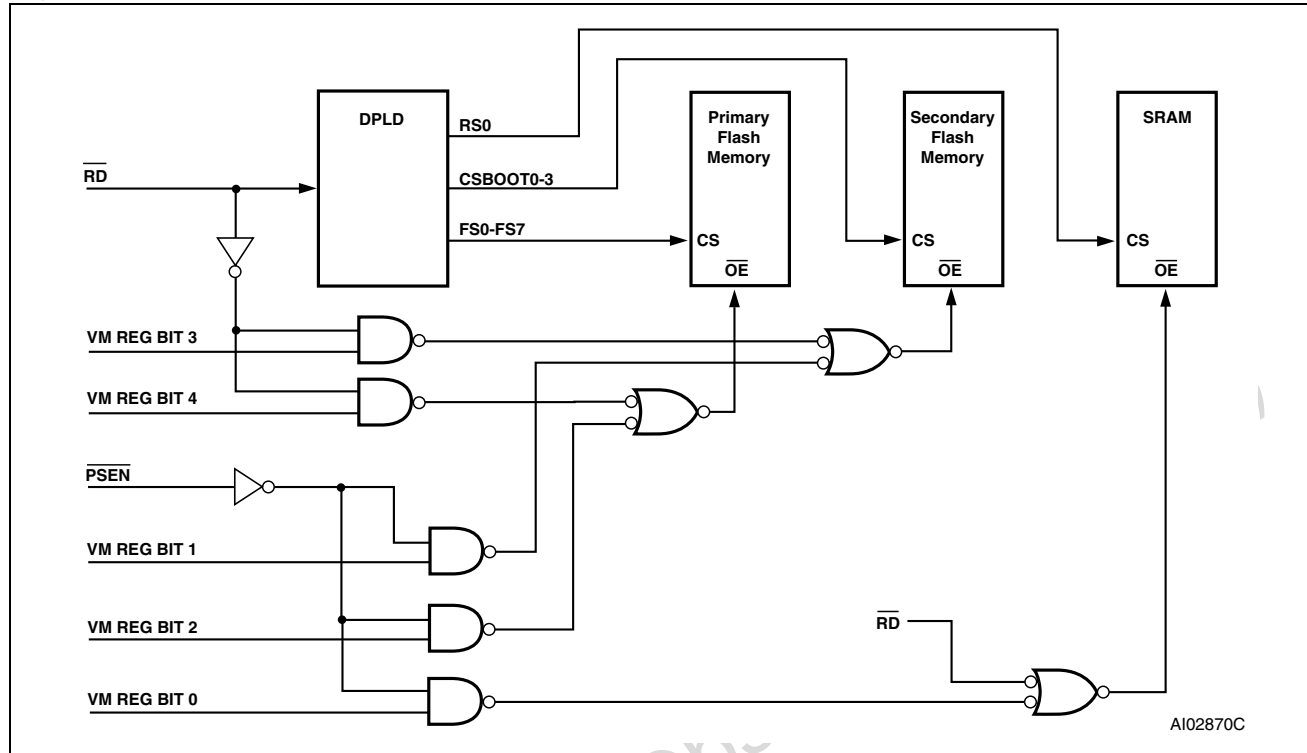

Page Register

The 8-bit Page Register increases the addressing capability of the MCU by a factor of up to 256. The contents of the register can also be read by the MCU. The outputs of the Page Register (PGR0-PGR7) are inputs to the DPLD decoder and can be included in the Sector Select (FS0-FS7, CSBOOT0-CSBOOT3), and SRAM Select (RS0) equations.

If memory paging is not needed, or if not all 8 page register bits are needed for memory paging, then these bits may be used in the CPLD for general logic. See Application Note AN1154.

Figure 9 shows the Page Register. The eight flip-flops in the register are connected to the internal data bus D0-D7. The MCU can write to or read from the Page Register. The Page Register can be accessed at address location CSIOP + E0h.

Figure 9. Page Register

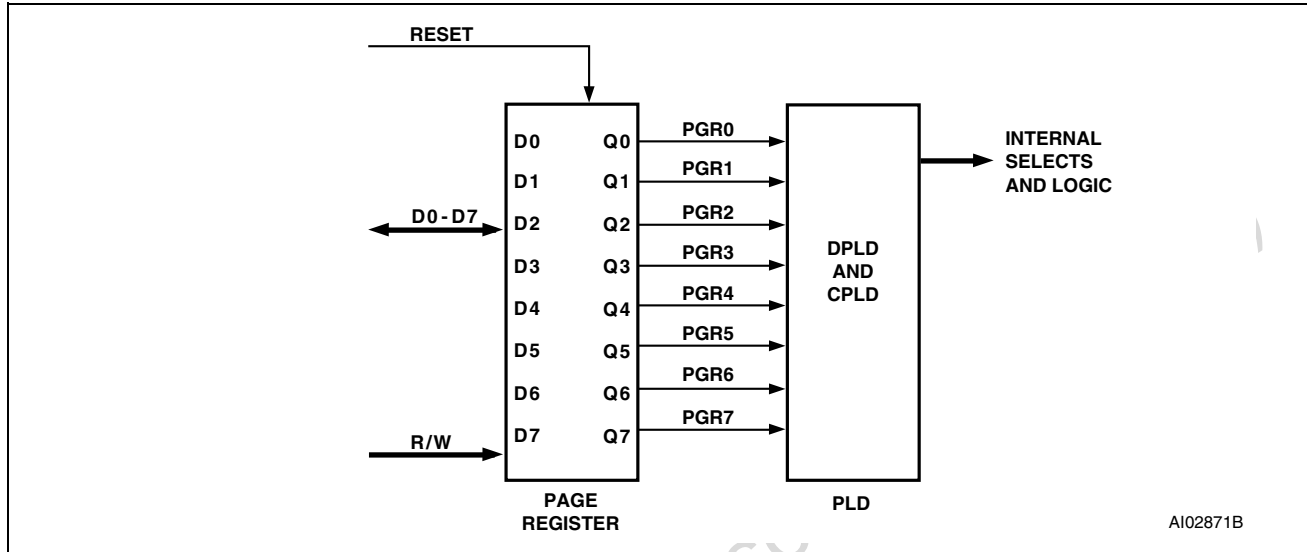

Obsolete Product(s) - Obs

PLDS

The PLDs bring programmable logic functionality to the PSD. After specifying the logic for the PLDs using the PSDabel tool in PSDsoft Express, the logic is programmed into the device and available upon Power-up.

The PSD contains two PLDs: the Decode PLD (DPLD), and the Complex PLD (CPLD). The PLDs are briefly discussed in the next few paragraphs, and in more detail in the section entitled “Decode PLD (DPLD)”, on page 29, and the section entitled “Complex PLD (CPLD)”, also on page 30. Figure 10 shows the configuration of the PLDs.

The DPLD performs address decoding for Select signals for internal components, such as memory, registers, and I/O ports.

The CPLD can be used for logic functions, such as loadable counters and shift registers, state machines, and encoding and decoding logic. These logic functions can be constructed using the 16 Output Macrocells (OMC), 24 Input Macrocells (IMC), and the AND Array. The CPLD can also be used to generate External Chip Select (ECS0-ECS2) signals.

The AND Array is used to form product terms. These product terms are specified using PSDabel. An Input Bus consisting of 73 signals is connected to the PLDs. The signals are shown in Table 12.

The Turbo Bit in PSD

The PLDs in the PSD can minimize power consumption by switching off when inputs remain unchanged for an extended time of about 70ns. Resetting the Turbo Bit to '0' (Bit 3 of PMMR0) automatically places the PLDs into standby if no inputs are changing. Turning the Turbo mode off increases propagation delays while reducing power consumption. See the section entitled “POWER MANAGEMENT”, on page 56, on how to set the Turbo Bit.

Additionally, five bits are available in PMMR2 to block MCU control signals from entering the PLDs. This reduces power consumption and can be used only when these MCU control signals are not used in PLD logic equations.

Each of the two PLDs has unique characteristics suited for its applications. They are described in the following sections.

Table 12. DPLD and CPLD Inputs

Input Source	Input Name	Number of Signals
MCU Address Bus ¹	A15-A0	16
MCU Control Signals	CNTL2-CNTL0	3
Reset	\overline{RST}	1
Power-down	PDN	1
Port A Input Macrocells	PA7-PA0	8
Port B Input Macrocells	PB7-PB0	8
Port C Input Macrocells	PC7-PC0	8
Port D Inputs	PD2-PD0	3
Page Register	PGR7-PGR0	8
Macrocell AB Feedback	MCELLAB.FB7-FB0	8
Macrocell BC Feedback	MCELLBC.FB7-FB0	8
Secondary Flash memory Program Status Bit	Ready/ \overline{Busy}	1

Note: 1. The address inputs are A19-A4 in 80C51XA mode.

Figure 10. PLD Diagram

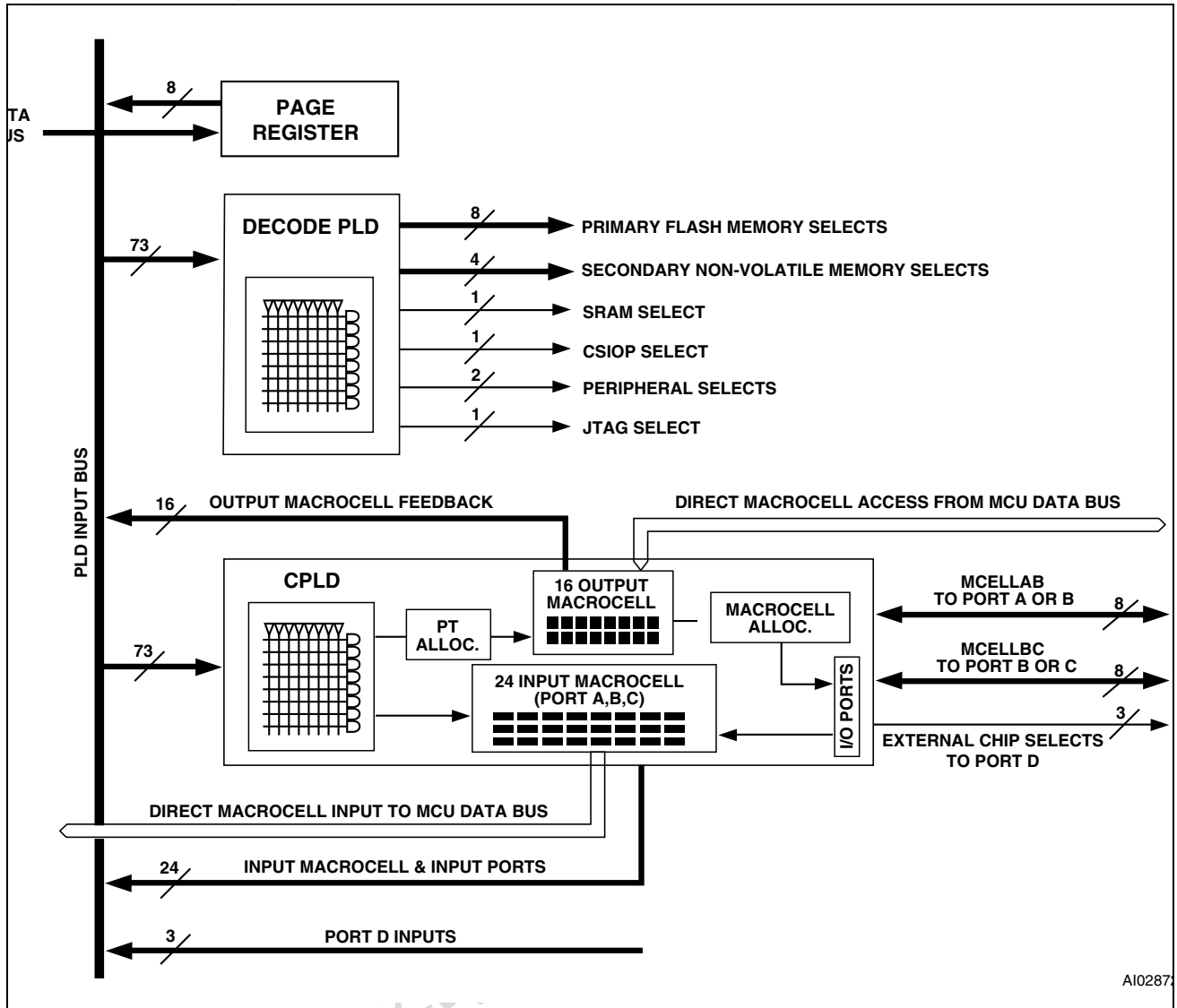

AI0287

Decode PLD (DPLD)

The DPLD, shown in Figure 11, is used for decoding the address for internal and external components. The DPLD can be used to generate the following decode signals:

- 8 Sector Select (FS0-FS7) signals for the primary Flash memory (three product terms each)
- 4 Sector Select (CSBOOT0-CSBOOT3) signals for the secondary Flash memory (three product terms each)
- 1 internal SRAM Select (RS0) signal (two product terms)
- 1 internal CSIOP Select (PSD Configuration Register) signal
- 1 JTAG Select signal (enables JTAG on Port C)
- 2 internal Peripheral Select signals (Peripheral I/O mode).

Figure 11. DPLD Logic Array

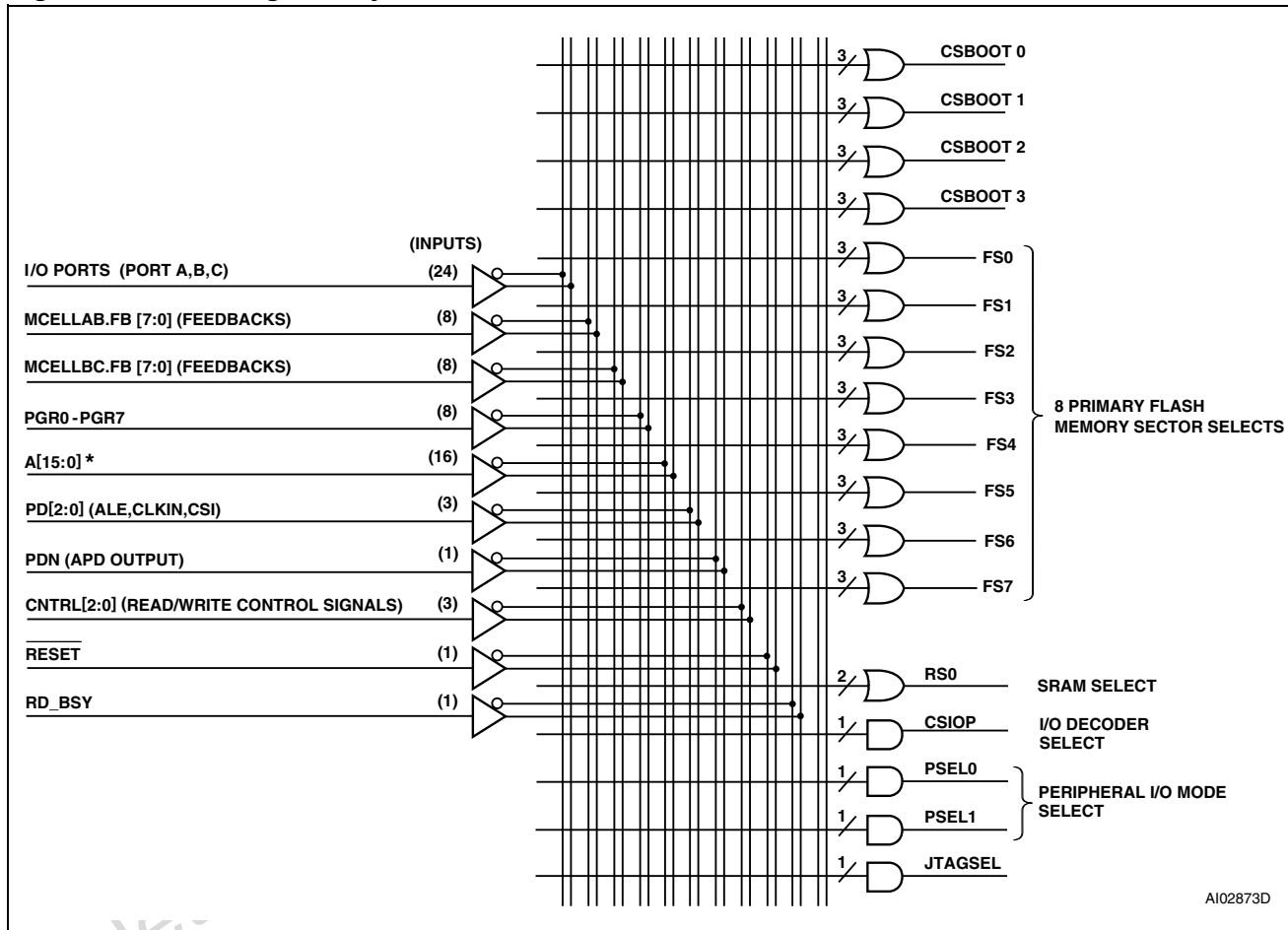

AI02873D

Obsolte

Complex PLD (CPLD)

The CPLD can be used to implement system logic functions, such as loadable counters and shift registers, system mailboxes, handshaking protocols, state machines, and random logic. The CPLD can also be used to generate three External Chip Select (ECS0-ECS2), routed to Port D.

Although External Chip Select (ECS0-ECS2) can be produced by any Output Macrocell (OMC), these three External Chip Select (ECS0-ECS2) on Port D do not consume any Output Macrocells (OMC).

As shown in Figure 10, the CPLD has the following blocks:

- 24 Input Macrocells (IMC)
- 16 Output Macrocells (OMC)
- Macrocell Allocator

- Product Term Allocator
- AND Array capable of generating up to 137 product terms
- Four I/O Ports.

Each of the blocks are described in the sections that follow.

The Input Macrocells (IMC) and Output Macrocells (OMC) are connected to the PSD internal data bus and can be directly accessed by the MCU. This enables the MCU software to load data into the Output Macrocells (OMC) or read data from both the Input and Output Macrocells (IMC and OMC).

This feature allows efficient implementation of system logic and eliminates the need to connect the data bus to the AND Array as required in most standard PLD macrocell architectures.

Obsolete Product(s) - Obsolete Product(s)

Figure 12. Macrocell and I/O Port

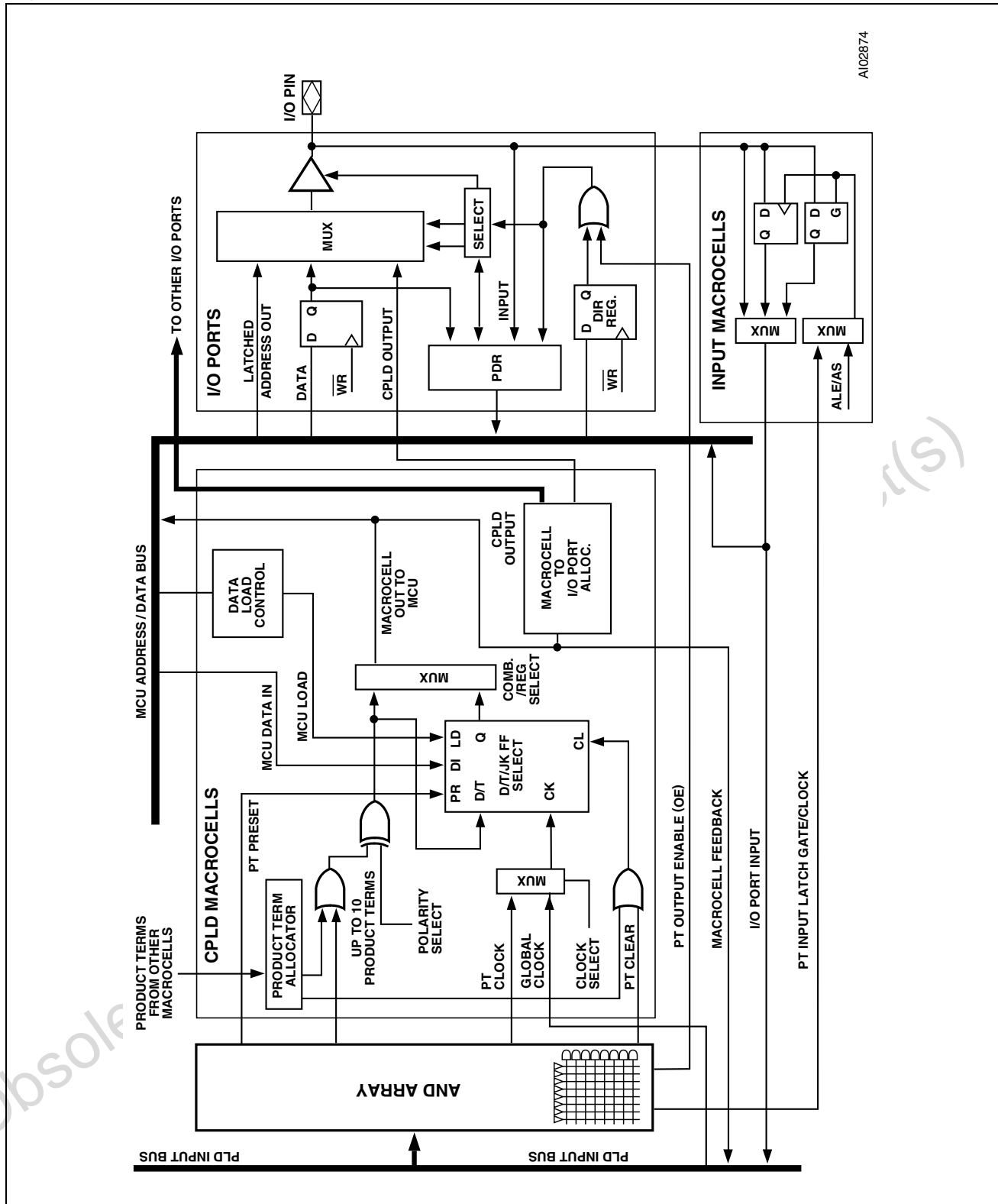

Output Macrocell (OMC)

Eight of the Output Macrocells (OMC) are connected to Ports A and B pins and are named as McellAB0-McellAB7. The other eight macrocells are connected to Ports B and C pins and are named as McellBC0-McellBC7. If an McellAB output is not assigned to a specific pin in PSDabel, the Macrocell Allocator block assigns it to either Port A or B. The same is true for a McellBC output on Port B or C. Table 13 shows the macrocells and port assignment.

The Output Macrocell (OMC) architecture is shown in Figure 13. As shown in the figure, there are native product terms available from the AND Array, and borrowed product terms available (if unused) from other Output Macrocells (OMC). The polarity of the product term is controlled by the

XOR gate. The Output Macrocell (OMC) can implement either sequential logic, using the flip-flop element, or combinatorial logic. The multiplexer selects between the sequential or combinatorial logic outputs. The multiplexer output can drive a port pin and has a feedback path to the AND Array inputs.

The flip-flop in the Output Macrocell (OMC) block can be configured as a D, T, JK, or SR type in the PSDabel program. The flip-flop's clock, preset, and clear inputs may be driven from a product term of the AND Array. Alternatively, CLKIN (PD1) can be used for the clock input to the flip-flop. The flip-flop is clocked on the rising edge of CLKIN (PD1). The preset and clear are active High inputs. Each clear input can use up to two product terms.

Table 13. Output Macrocell Port and Data Bit Assignments

Output Macrocell	Port Assignment	Native Product Terms	Maximum Borrowed Product Terms	Data Bit for Loading or Reading
McellAB0	Port A0, B0	3	6	D0
McellAB1	Port A1, B1	3	6	D1
McellAB2	Port A2, B2	3	6	D2
McellAB3	Port A3, B3	3	6	D3
McellAB4	Port A4, B4	3	6	D4
McellAB5	Port A5, B5	3	6	D5
McellAB6	Port A6, B6	3	6	D6
McellAB7	Port A7, B7	3	6	D7
McellBC0	Port B0, C0	4	5	D0
McellBC1	Port B1, C1	4	5	D1
McellBC2	Port B2, C2	4	5	D2
McellBC3	Port B3, C3	4	5	D3
McellBC4	Port B4, C4	4	6	D4
McellBC5	Port B5, C5	4	6	D5
McellBC6	Port B6, C6	4	6	D6
McellBC7	Port B7, C7	4	6	D7

Product Term Allocator

The CPLD has a Product Term Allocator. The PSDabel compiler uses the Product Term Allocator to borrow and place product terms from one macrocell to another. The following list summarizes how product terms are allocated:

- McellAB0-McellAB7 all have three native product terms and may borrow up to six more
- McellBC0-McellBC3 all have four native product terms and may borrow up to five more
- McellBC4-McellBC7 all have four native product terms and may borrow up to six more.

Each macrocell may only borrow product terms from certain other macrocells. Product terms already in use by one macrocell are not available for another macrocell.

If an equation requires more product terms than are available to it, then “external” product terms are required, which consume other Output Macrocells (OMC). If external product terms are used, extra delay is added for the equation that required the extra product terms.

This is called product term expansion. PSDsoft Express performs this expansion as needed.

Loading and Reading the Output Macrocells (OMC). The Output Macrocells (OMC) block occupies a memory location in the MCU address space, as defined by the CSIOP block (see the section entitled “I/O PORTS”, on page 46). The flip-flops in each of the 16 Output Macrocells (OMC) can be loaded from the data bus by a MCU. Loading the Output Macrocells (OMC) with data from the MCU takes priority over internal functions. As such, the preset, clear, and clock inputs to the flip-flop can be overridden by the MCU. The ability to load the flip-flops and read them back is useful in such applications as loadable counters and shift registers, mailboxes, and handshaking protocols.

Data can be loaded to the Output Macrocells (OMC) on the trailing edge of Write Strobe (\overline{WR} , CNTL0) (edge loading) or during the time that Write Strobe (\overline{WR} , CNTL0) is active (level loading). The method of loading is specified in PSDsoft Express Configuration.

Figure 13. CPLD Output Macrocell

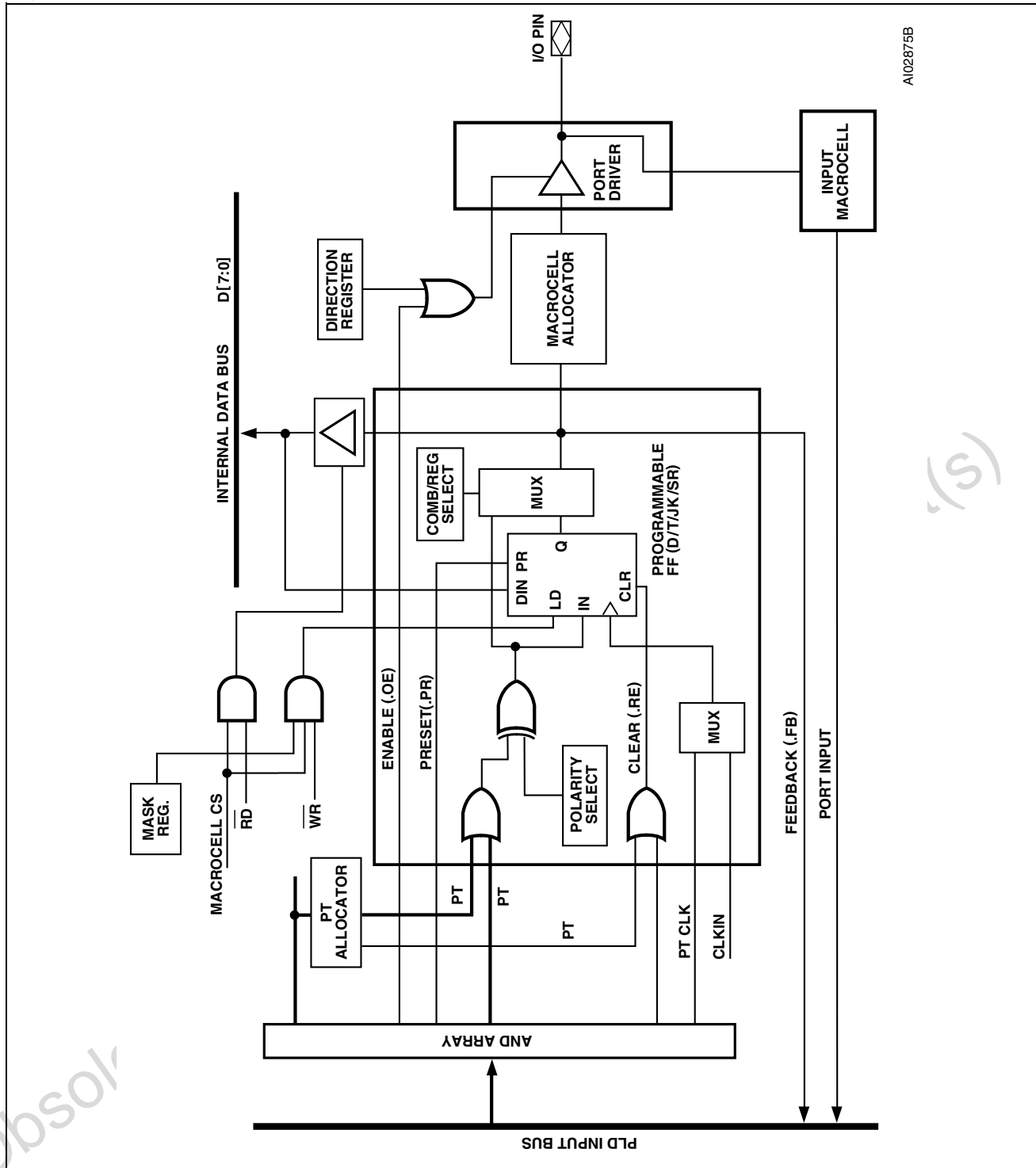

The OMC Mask Register. There is one Mask Register for each of the two groups of eight Output Macrocells (OMC). The Mask Registers can be used to block the loading of data to individual Output Macrocells (OMC). The default value for the Mask Registers is 00h, which allows loading of the Output Macrocells (OMC). When a given bit in a Mask Register is set to a 1, the MCU is blocked from writing to the associated Output Macrocells (OMC). For example, suppose McellAB0-McellAB3 are being used for a state machine. You would not want an MCU WRITE to McellAB to overwrite the state machine registers. Therefore, you would want to load the Mask Register for McellAB (Mask Macrocell AB) with the value 0Fh.

The Output Enable of the OMC. The Output Macrocells (OMC) block can be connected to an I/O port pin as a PLD output. The output enable of each port pin driver is controlled by a single product term from the AND Array, OR'ed with the Direction Register output. The pin is enabled upon Power-up if no output enable equation is defined and if the pin is declared as a PLD output in PSDsoft Express.

If the Output Macrocell (OMC) output is declared as an internal node and not as a port pin output in the PSDabel file, the port pin can be used for other I/O functions. The internal node feedback can be routed as an input to the AND Array.

Input Macrocells (IMC)

The CPLD has 24 Input Macrocells (IMC), one for each pin on Ports A, B, and C. The architecture of the Input Macrocells (IMC) is shown in Figure 14. The Input Macrocells (IMC) are individually configurable, and can be used as a latch, register, or to pass incoming Port signals prior to driving them

onto the PLD input bus. The outputs of the Input Macrocells (IMC) can be read by the MCU through the internal data bus.

The enable for the latch and clock for the register are driven by a multiplexer whose inputs are a product term from the CPLD AND Array or the MCU Address Strobe (ALE/AS). Each product term output is used to latch or clock four Input Macrocells (IMC). Port inputs 3-0 can be controlled by one product term and 7-4 by another.

Configurations for the Input Macrocells (IMC) are specified by equations written in PSDabel (see Application Note AN1171). Outputs of the Input Macrocells (IMC) can be read by the MCU via the IMC buffer. See the section entitled "I/O PORTS", on page 46.

Input Macrocells (IMC) can use Address Strobe (ALE/AS, PD0) to latch address bits higher than A15. Any latched addresses are routed to the PLDs as inputs.

Input Macrocells (IMC) are particularly useful with handshaking communication applications where two processors pass data back and forth through a common mailbox. Figure 15 shows a typical configuration where the Master MCU writes to the Port A Data Out Register. This, in turn, can be read by the Slave MCU via the activation of the "Slave-Read" output enable product term.

The Slave can also write to the Port A Input Macrocells (IMC) and the Master can then read the Input Macrocells (IMC) directly.

Note that the "Slave-Read" and "Slave-Wr" signals are product terms that are derived from the Slave MCU inputs Read Strobe (RD, CNTL1), Write Strobe (WR, CNTL0), and Slave_CS.

Figure 14. Input Macrocell

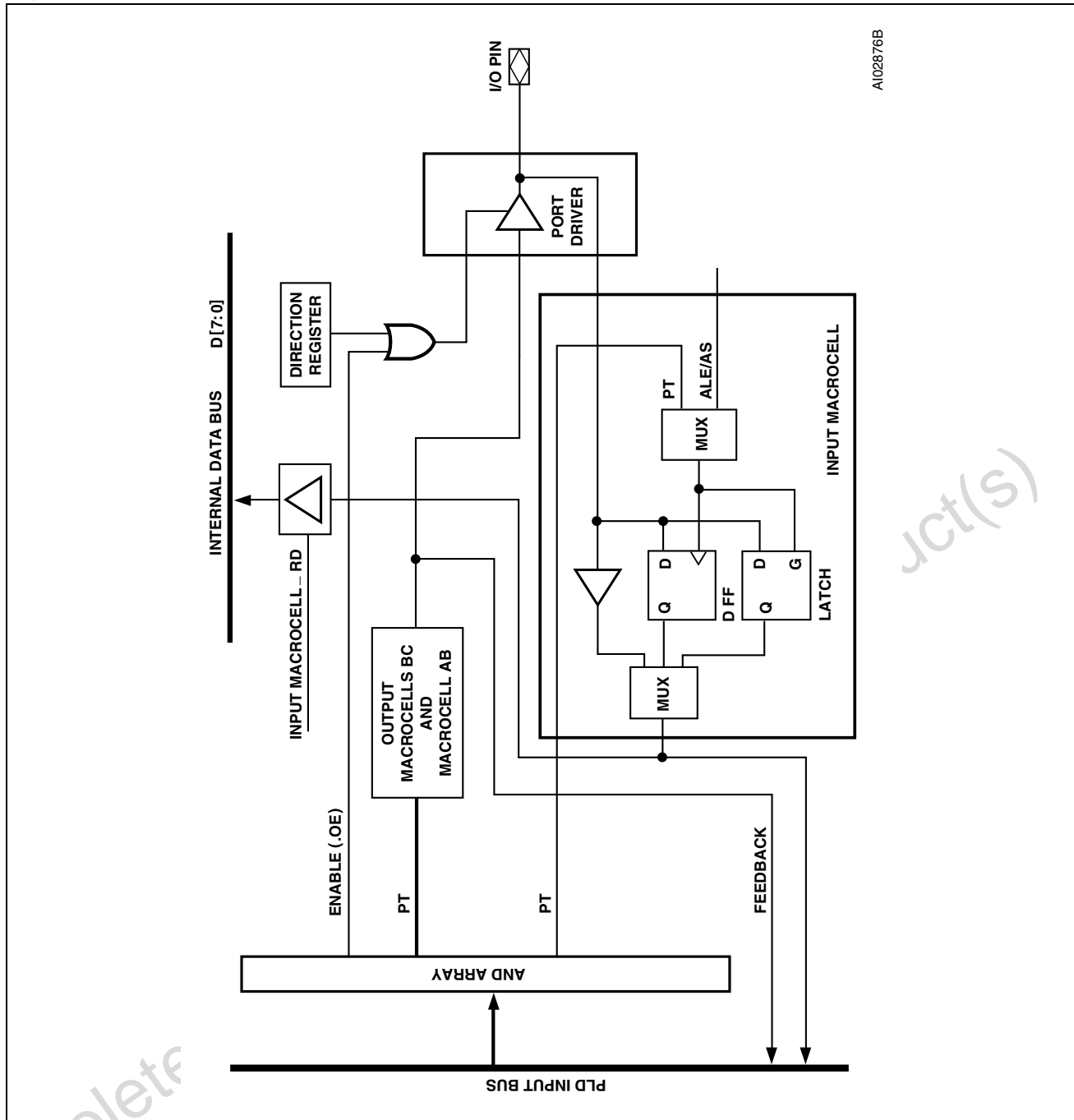

Obsolete

uct(s)

Figure 15. Handshaking Communication Using Input Macrocells

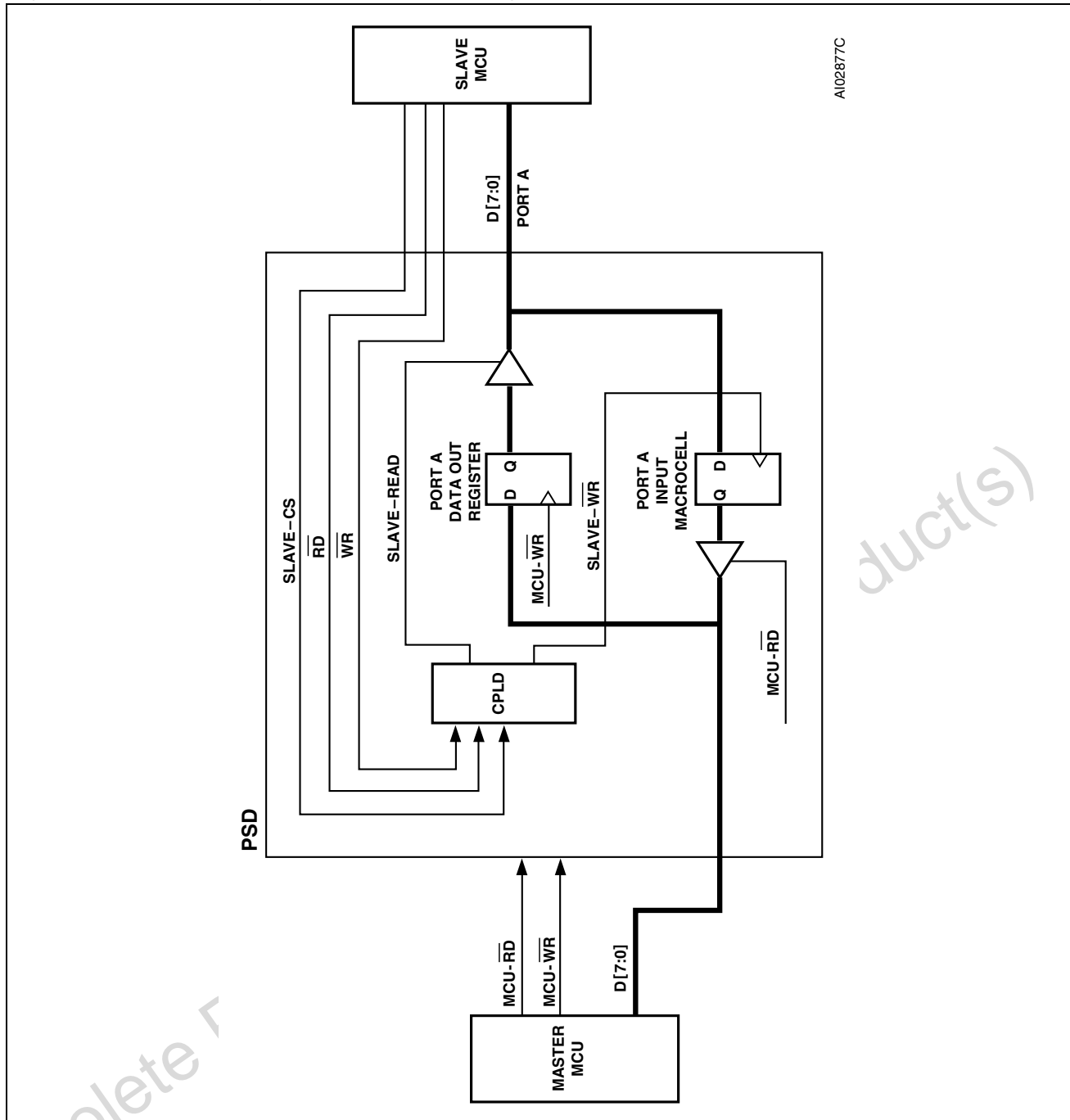

Obsolete r

duct(s)

MCU BUS INTERFACE

The “no-glue logic” MCU Bus Interface block can be directly connected to most popular MCUs and their control signals. Key 8-bit MCUs, with their bus types and control signals, are shown in Table 14. The interface type is specified using the PSD-soft Express Configuration.

PSD Interface to a Multiplexed 8-Bit Bus. Figure 16 shows an example of a system using a MCU with an 8-bit multiplexed bus and a PSD. The

ADIO port on the PSD is connected directly to the MCU address/data bus. Address Strobe (ALE/AS, PD0) latches the address signals internally. Latched addresses can be brought out to Port A or B. The PSD drives the ADIO data bus only when one of its internal resources is accessed and Read Strobe (\overline{RD} , CNTL1) is active. Should the system address bus exceed sixteen bits, Ports A, B, C, or D may be used as additional address inputs.

Table 14. MCUs and their Control Signals

MCU	Data Bus Width	CNTL0	CNTL1	CNTL2	PC7	PD0 ²	ADIO0	PA3-PA0	PA7-PA3
8031	8	\overline{WR}	\overline{RD}	\overline{PSEN}	(Note 1)	ALE	A0	(Note 1)	(Note 1)
80C51XA	8	\overline{WR}	\overline{RD}	\overline{PSEN}	(Note 1)	ALE	A4	A3-A0	(Note 1)
80C251	8	\overline{WR}	\overline{PSEN}	(Note 1)	(Note 1)	ALE	A0	(Note 1)	(Note 1)
80C251	8	\overline{WR}	\overline{RD}	\overline{PSEN}	(Note 1)	ALE	A0	(Note 1)	(Note 1)
80198	8	\overline{WR}	\overline{RD}	(Note 1)	(Note 1)	ALE	A0	(Note 1)	(Note 1)
68HC11	8	R/ \overline{W}	E	(Note 1)	(Note 1)	AS	A0	(Note 1)	(Note 1)
68HC912	8	R/ \overline{W}	E	(Note 1)	\overline{DBE}	AS	A0	(Note 1)	(Note 1)
Z80	8	\overline{WR}	\overline{RD}	(Note 1)	(Note 1)	(Note 1)	A0	D3-D0	D7-D4
Z8	8	R/ \overline{W}	\overline{DS}	(Note 1)	(Note 1)	\overline{AS}	A0	(Note 1)	(Note 1)
68330	8	R/ \overline{W}	\overline{DS}	(Note 1)	(Note 1)	AS	A0	(Note 1)	(Note 1)
M37702M2	8	R/ \overline{W}	\overline{E}	(Note 1)	(Note 1)	ALE	A0	D3-D0	D7-D4

Note: 1. Unused CNTL2 pin can be configured as CPLD input. Other unused pins (PC7, PD0, PA3-0) can be configured for other I/O functions.

2. ALE/AS input is optional for MCUs with a non-multiplexed bus

Figure 16. An Example of a Typical 8-bit Multiplexed Bus Interface

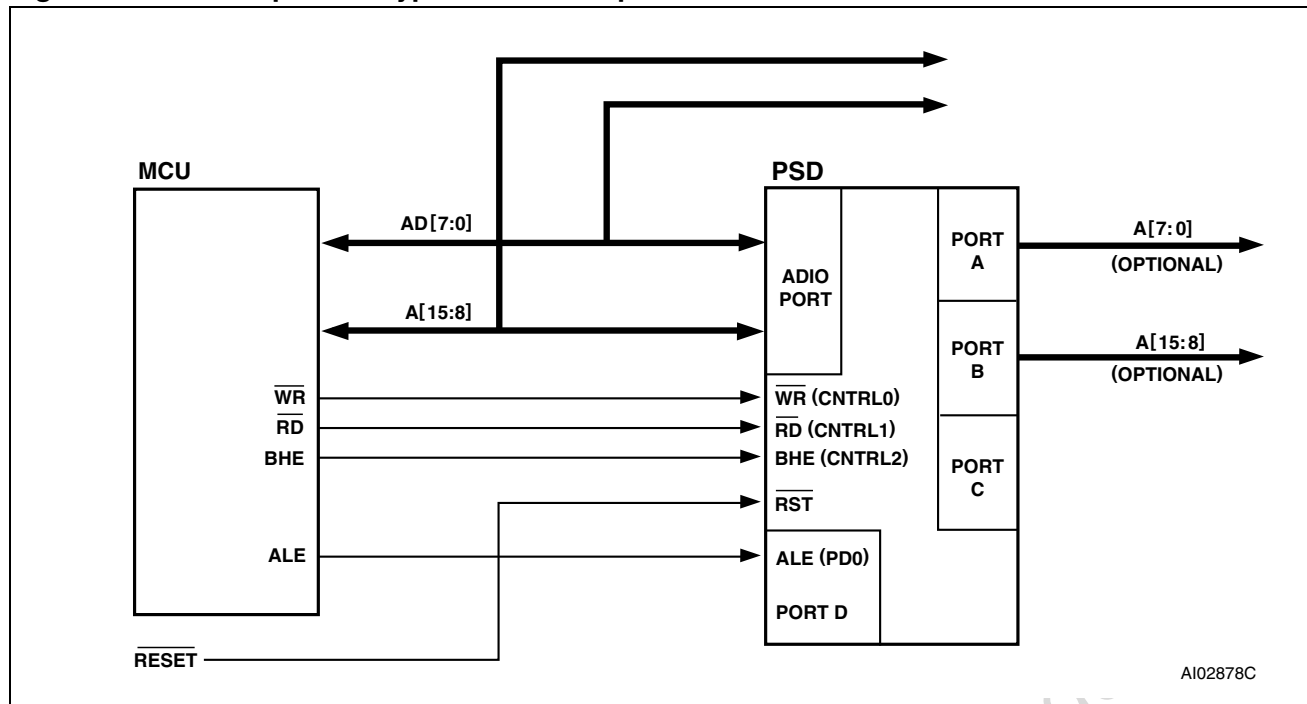

Obsolete Product(s) - Obsolete Product(s)

PSD Interface to a Non-Multiplexed 8-bit Bus.

Figure 17 shows an example of a system using a MCU with an 8-bit non-multiplexed bus and a PSD. The address bus is connected to the ADIO Port, and the data bus is connected to Port A. Port A is in tri-state mode when the PSD is not accessed by the MCU. Should the system address bus exceed sixteen bits, Ports B, C, or D may be used for additional address inputs.

Data Byte Enable Reference. MCUs have different data byte orientations. Table 15 shows how the PSD interprets byte/word operations in different bus WRITE configurations. Even-byte refers to locations with address A0 equal to 0 and odd byte as locations with A0 equal to 1.

Table 15. 8-bit Data Bus

BHE	A0	D7-D0
X	0	Even Byte
X	1	Odd Byte

Figure 17. An Example of a Typical 8-bit Non-Multiplexed Bus Interface

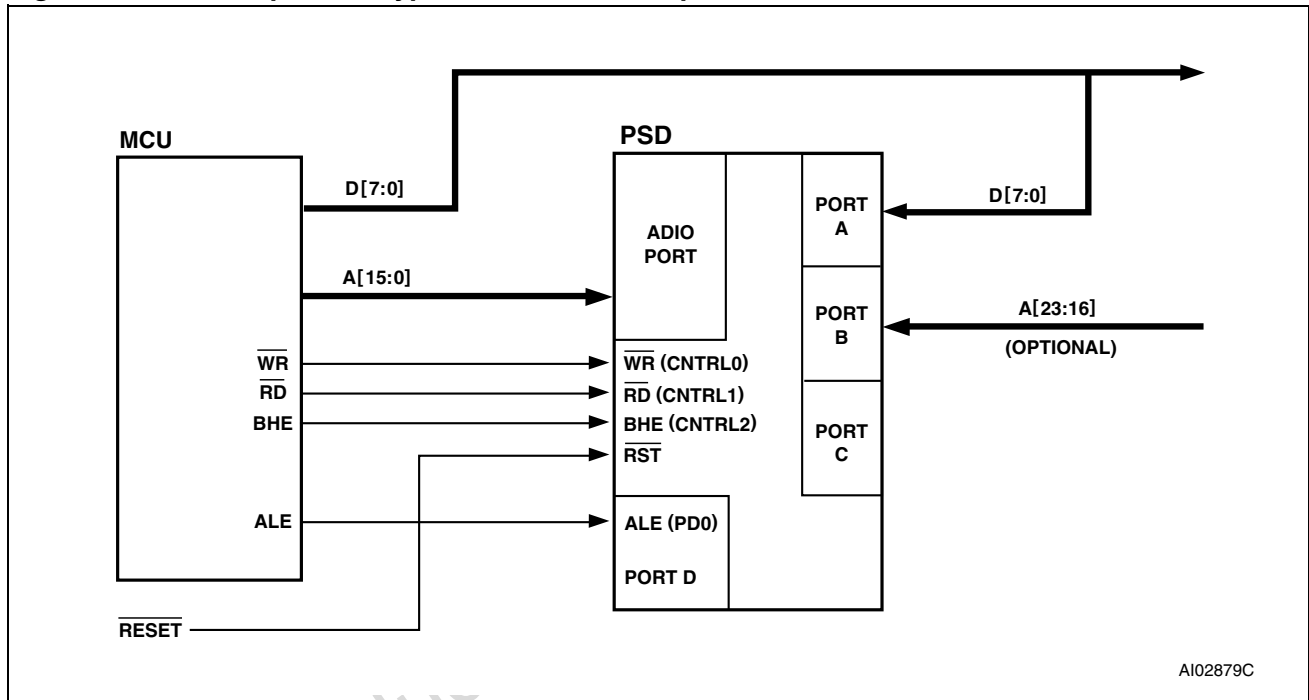

AI02879C

MCU Bus Interface Examples

Figure 18 to Figure 21 show examples of the basic connections between the PSD and some popular MCUs. The PSD Control input pins are labeled as to the MCU function for which they are configured. The MCU bus interface is specified using the PSD-soft Express Configuration.

80C31. Figure 18 shows the bus interface for the 80C31, which has an 8-bit multiplexed address/data bus. The lower address byte is multiplexed

with the data bus. The MCU control signals Program Select Enable ($\overline{\text{PSEN}}$, CNTL2), Read Strobe ($\overline{\text{RD}}$, CNTL1), and Write Strobe ($\overline{\text{WR}}$, CNTL0) may be used for accessing the internal memory and I/O Ports blocks. Address Strobe (ALE/AS , PD0) latches the address.

80C251. The Intel 80C251 MCU features a user-configurable bus interface with four possible bus configurations, as shown in Table 16.

Figure 18. Interfacing the PSD with an 80C31

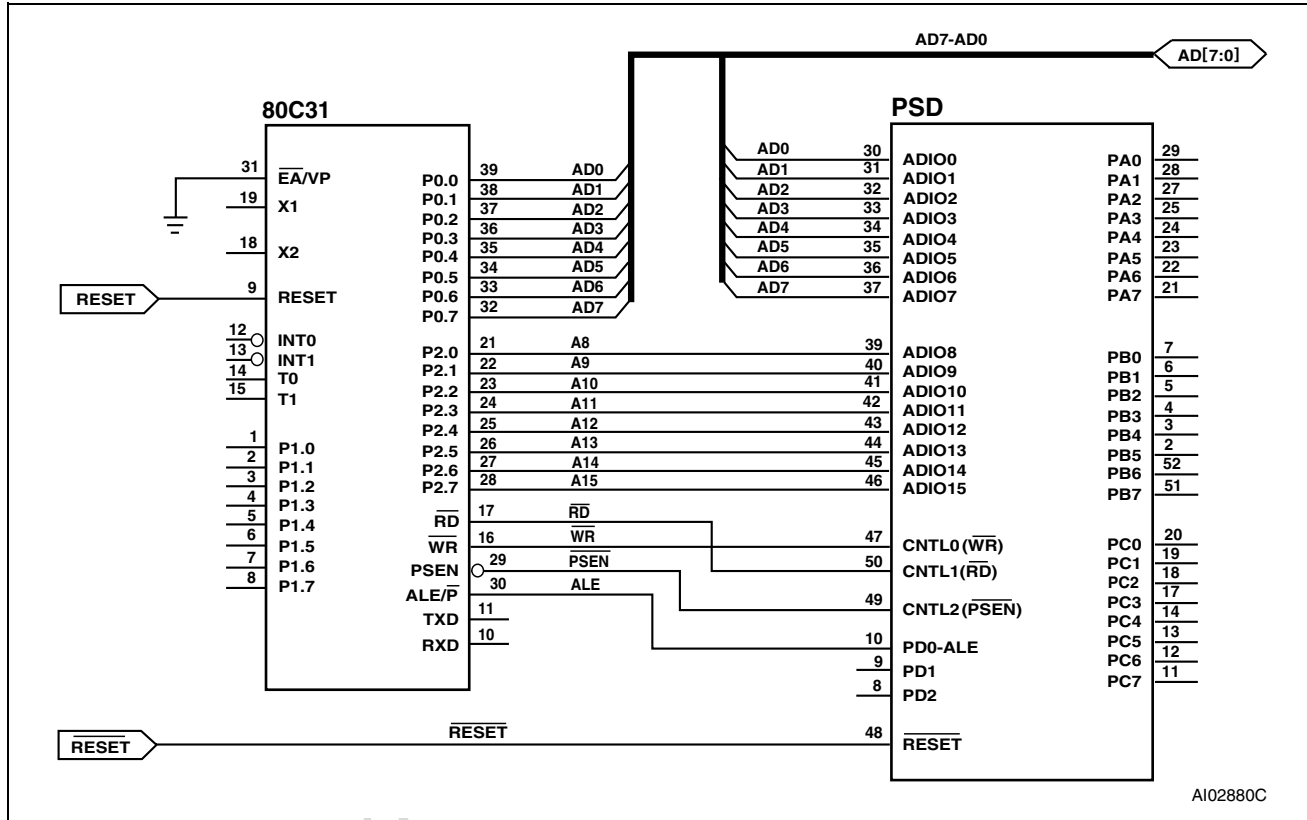

Table 16. 80C251 Configurations

Configuration	80C251 READ/WRITE Pins	Connecting to PSD Pins	Page Mode
1	$\overline{\text{WR}}$ $\overline{\text{RD}}$ $\overline{\text{PSEN}}$	CNTL0 CNTL1 CNTL2	Non-Page Mode, 80C31 compatible A7-A0 multiplex with D7-D0
2	$\overline{\text{WR}}$ $\overline{\text{PSEN}}$ only	CNTL0 CNTL1	Non-Page Mode A7-A0 multiplex with D7-D0
3	$\overline{\text{WR}}$ $\overline{\text{PSEN}}$ only	CNTL0 CNTL1	Page Mode A15-A8 multiplex with D7-D0
4	$\overline{\text{WR}}$ $\overline{\text{RD}}$ $\overline{\text{PSEN}}$	CNTL0 CNTL1 CNTL2	Page Mode A15-A8 multiplex with D7-D0

The first configuration is 80C31 compatible, and the bus interface to the PSD is identical to that shown in Figure 18. The second and third configurations have the same bus connection as shown in Figure 17. There is only one Read Strobe ($\overline{\text{PSEN}}$) connected to CNTL1 on the PSD. The A16 connection to PA0 allows for a larger address input to the PSD. The fourth configuration is shown in Figure 19. Read Strobe ($\overline{\text{RD}}$) is connected to CNTL1 and Program Select Enable ($\overline{\text{PSEN}}$) is connected to CNTL2.

The 80C251 has two major operating modes: Page mode and Non-page mode. In Non-page

mode, the data is multiplexed with the lower address byte, and Address Strobe (ALE/AS, PD0) is active in every bus cycle. In Page mode, data (D7-D0) is multiplexed with address (A15-A8). In a bus cycle where there is a Page hit, Address Strobe (ALE/AS, PD0) is not active and only addresses (A7-A0) are changing. The PSD supports both modes. In Page Mode, the PSD bus timing is identical to Non-Page Mode except the address hold time and setup time with respect to Address Strobe (ALE/AS, PD0) is not required. The PSD access time is measured from address (A7-A0) valid to data in valid.

Table 17. Interfacing the PSD with the 80C251, with One READ Input

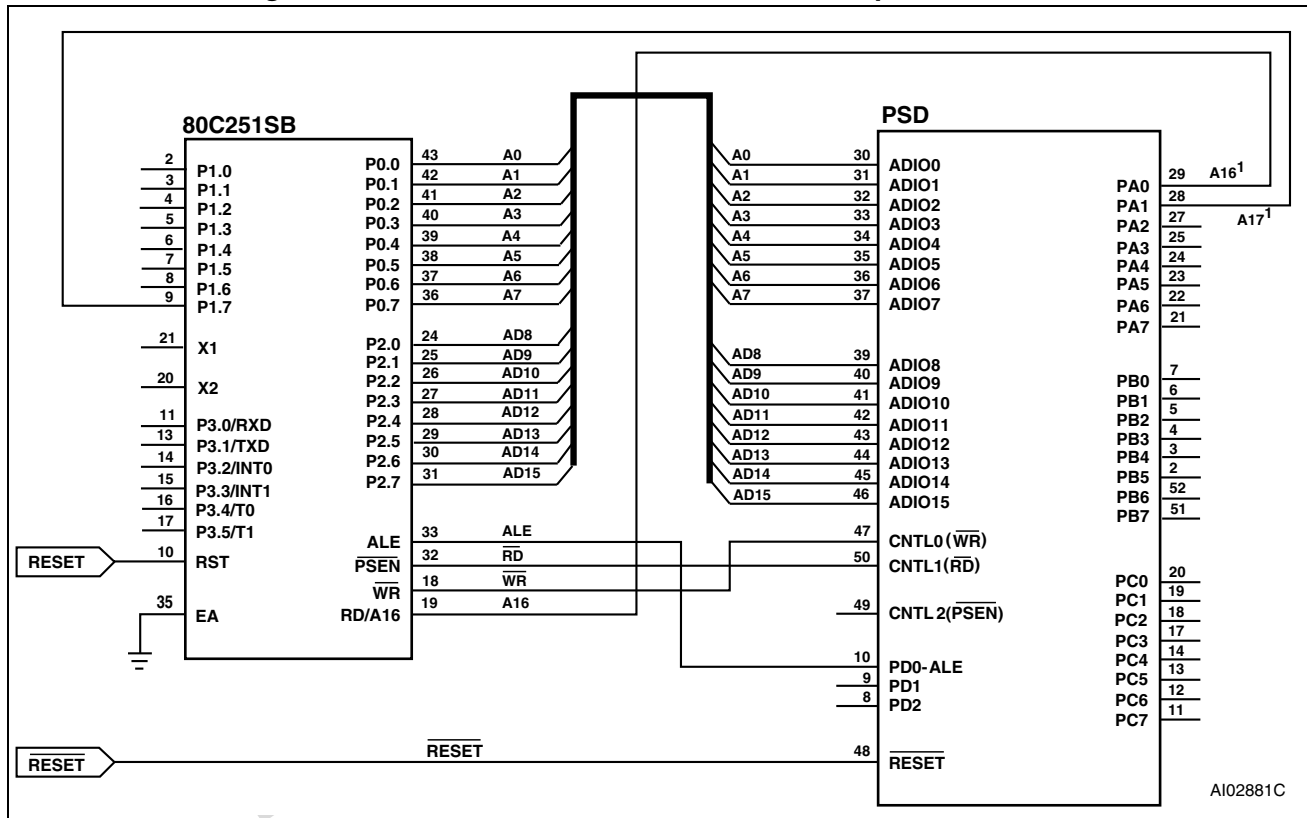

Note: 1. The A16 and A17 connections are optional.
 2. In non-Page-Mode, AD7-AD0 connects to ADIO7-ADIO0.

Figure 19. Interfacing the PSD with the 80C251, with \overline{RD} and \overline{PSEN} Inputs

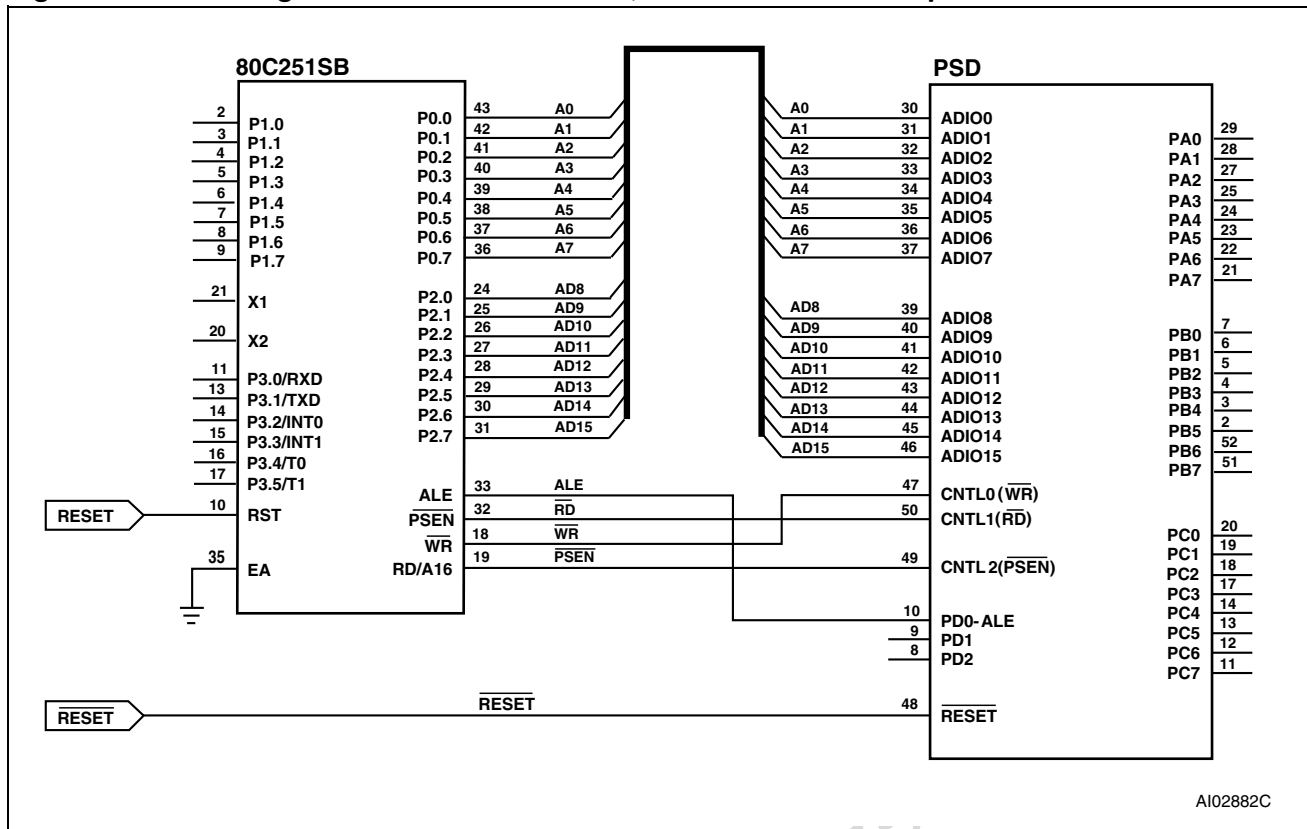

AI02882C

Obsolete Product(s) - Obsolete

80C51XA. The Philips 80C51XA MCU family supports an 8- or 16-bit multiplexed bus that can have burst cycles. Address bits (A3-A0) are not multiplexed, while (A19-A4) are multiplexed with data bits (D15-D0) in 16-bit mode. In 8-bit mode, (A11-A4) are multiplexed with data bits (D7-D0).

The 80C51XA can be configured to operate in 8-bit data mode (as shown in Figure 20).

The 80C51XA improves bus throughput and performance by executing burst cycles for code fetch-

es. In Burst Mode, address A19-A4 are latched internally by the PSD, while the 80C51XA changes the A3-A0 signals to fetch up to 16 bytes of code. The PSD access time is then measured from address A3-A0 valid to data in valid. The PSD bus timing requirement in Burst Mode is identical to the normal bus cycle, except the address setup and hold time with respect to Address Strobe (ALE/AS, PD0) does not apply.

Figure 20. Interfacing the PSD with the 80C51X, 8-bit Data Bus

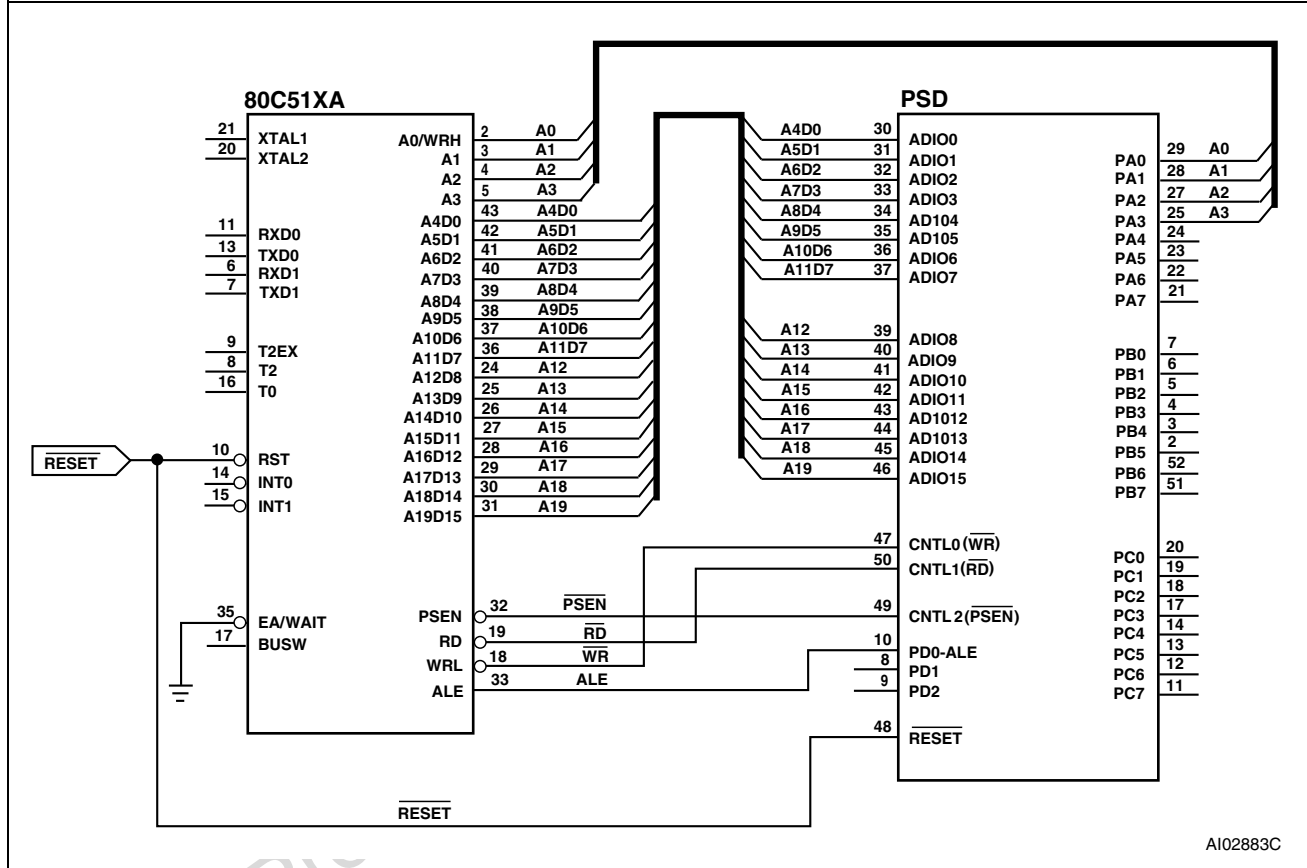

AI02883C

68HC11. Figure 21 shows a bus interface to a 68HC11 where the PSD is configured in 8-bit multiplexed mode with E and R/W settings. The DPLD

can be used to generate the READ and WR signals for external devices.

Figure 21. Interfacing the PSD with a 68HC11

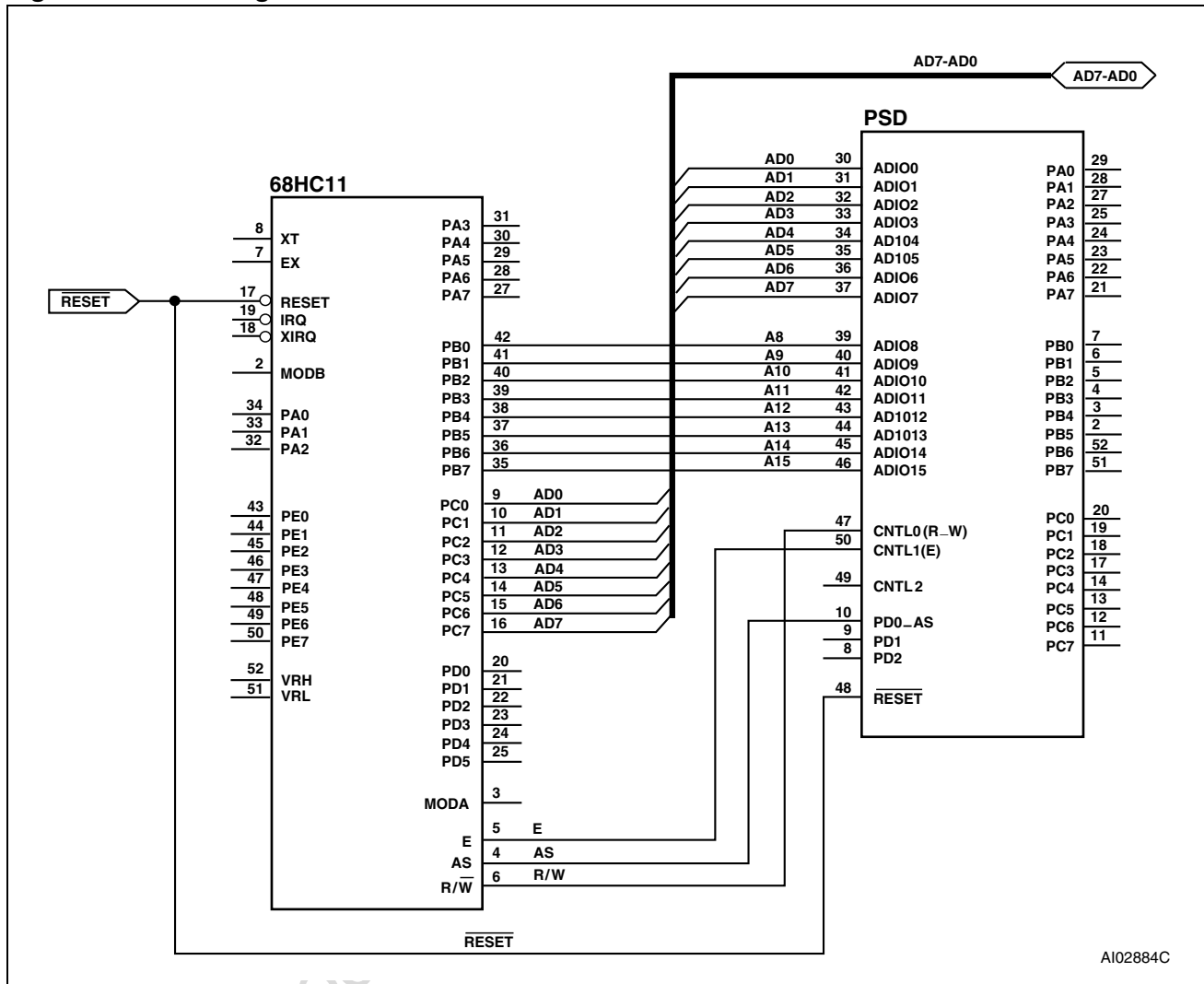

AI02884C

Obsolete Product

I/O PORTS

There are four programmable I/O ports: Ports A, B, C, and D. Each of the ports is eight bits except Port D, which is 3 bits. Each port pin is individually user configurable, thus allowing multiple functions per port. The ports are configured using PSDsoft Express Configuration or by the MCU writing to on-chip registers in the CSIOP space.

The topics discussed in this section are:

- General Port architecture
- Port operating modes
- Port Configuration Registers (PCR)
- Port Data Registers
- Individual Port functionality.

General Port Architecture

The general architecture of the I/O Port block is shown in Figure 22. Individual Port architectures are shown in Figure 24 to Figure 27. In general, once the purpose for a port pin has been defined,

that pin is no longer available for other purposes. Exceptions are noted.

As shown in Figure 22, the ports contain an output multiplexer whose select signals are driven by the configuration bits in the Control Registers (Ports A and B only) and PSDsoft Express Configuration. Inputs to the multiplexer include the following:

- Output data from the Data Out register
- Latched address outputs
- CPLD macrocell output
- External Chip Select (ECS0-ECS2) from the CPLD.

The Port Data Buffer (PDB) is a tri-state buffer that allows only one source at a time to be read. The Port Data Buffer (PDB) is connected to the Internal Data Bus for feedback and can be read by the MCU. The Data Out and macrocell outputs, Direction and Control Registers, and port pin input are all connected to the Port Data Buffer (PDB).

Figure 22. General I/O Port Architecture

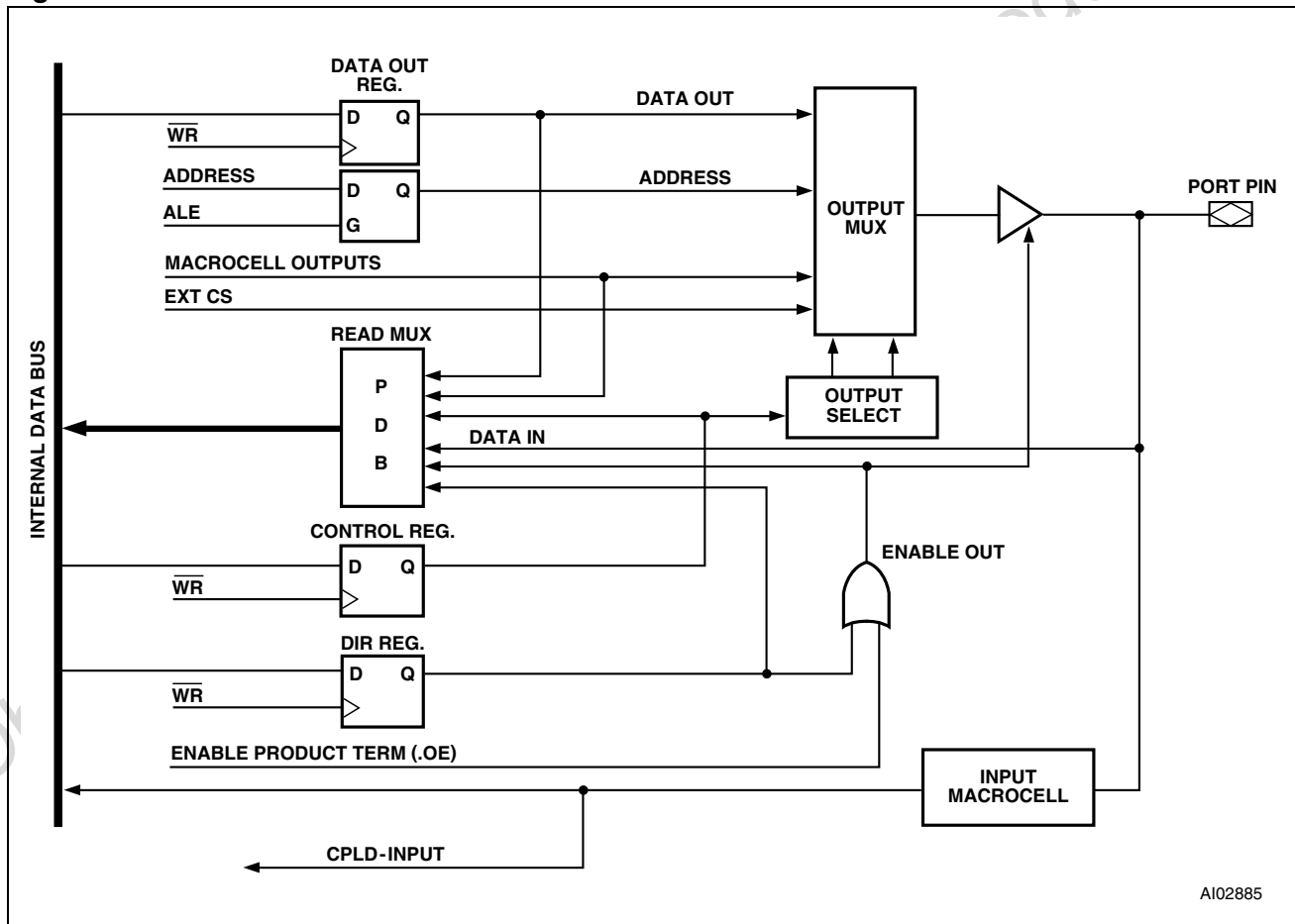

AI02885

The Port pin's tri-state output driver enable is controlled by a two input OR gate whose inputs come from the CPLD AND Array enable product term and the Direction Register. If the enable product term of any of the Array outputs are not defined and that port pin is not defined as a CPLD output in the PSDabel file, then the Direction Register has sole control of the buffer that drives the port pin.

The contents of these registers can be altered by the MCU. The Port Data Buffer (PDB) feedback path allows the MCU to check the contents of the registers.

Ports A, B, and C have embedded Input Macrocells (IMC). The Input Macrocells (IMC) can be configured as latches, registers, or direct inputs to the PLDs. The latches and registers are clocked by Address Strobe (ALE/AS, P_{DO}) or a product term from the PLD AND Array. The outputs from the Input Macrocells (IMC) drive the PLD input bus and can be read by the MCU. See the section entitled "Input Macrocell", on page 36.

Port Operating Modes

The I/O Ports have several modes of operation. Some modes can be defined using PSDabel, some by the MCU writing to the Control Registers in CS_{IOP} space, and some by both. The modes that can only be defined using PSDsoft Express must be programmed into the device and cannot be changed unless the device is reprogrammed. The modes that can be changed by the MCU can be done so dynamically at run-time. The PLD I/O, Data Port, Address Input, and Peripheral I/O modes are the only modes that must be defined before programming the device. All other modes can be changed by the MCU at run-time. See Application Note *AN1171* for more detail.

Table 18 summarizes which modes are available on each port. Table 21 shows how and where the different modes are configured. Each of the port operating modes are described in the following sections.

MCU I/O Mode

In the MCU I/O mode, the MCU uses the I/O Ports block to expand its own I/O ports. By setting up the CS_{IOP} space, the ports on the PSD are mapped into the MCU address space. The addresses of the ports are listed in Table 6.

A port pin can be put into MCU I/O mode by writing a 0 to the corresponding bit in the Control Register. The MCU I/O direction may be changed by writing to the corresponding bit in the Direction Register, or by the output enable product term. See the section entitled "Peripheral I/O Mode", on page 49. When the pin is configured as an output, the content of the Data Out Register drives the pin. When configured as an input, the MCU can read the port input through the Data In buffer. See Figure 22.

Ports C and D do not have Control Registers, and are in MCU I/O mode by default. They can be used for PLD I/O if equations are written for them in PSDabel.

PLD I/O Mode

The PLD I/O Mode uses a port as an input to the CPLD's Input Macrocells (IMC), and/or as an output from the CPLD's Output Macrocells (OMC). The output can be tri-stated with a control signal. This output enable control signal can be defined by a product term from the PLD, or by resetting the corresponding bit in the Direction Register to 0. The corresponding bit in the Direction Register must not be set to 1 if the pin is defined for a PLD input signal in PSDabel. The PLD I/O mode is specified in PSDabel by declaring the port pins, and then writing an equation assigning the PLD I/O to a port.

Address Out Mode

For MCUs with a multiplexed address/data bus, Address Out Mode can be used to drive latched addresses on to the port pins. These port pins can, in turn, drive external devices. Either the output enable or the corresponding bits of both the Direction Register and Control Register must be set to a 1 for pins to use Address Out Mode. This must be done by the MCU at run-time. See Table 20 for the address output pin assignments on Ports A and B for various MCUs.

For non-multiplexed 8-bit bus mode, address signals (A7-A0) are available to Port B in Address Out Mode.

Note: Do not drive address signals with Address Out Mode to an external memory device if it is intended for the MCU to Boot from the external device. The MCU must first Boot from PSD memory so the Direction and Control register bits can be set.

Table 18. Port Operating Modes

Port Mode	Port A	Port B	Port C	Port D
MCU I/O	Yes	Yes	Yes	Yes
PLD I/O				
McellAB Outputs	Yes	Yes	No	No
McellBC Outputs	No	Yes	Yes	No
Additional Ext. CS Outputs	No	No	No	Yes
PLD Inputs	Yes	Yes	Yes	Yes
Address Out	Yes (A7 – 0)	Yes (A7 – 0) or (A15 – 8)	No	No
Address In	Yes	Yes	Yes	Yes
Data Port	Yes (D7 – 0)	No	No	No
Peripheral I/O	Yes	No	No	No
JTAG ISP	No	No	Yes ¹	No

Note: 1. Can be multiplexed with other I/O functions.

Table 19. Port Operating Mode Settings

Mode	Defined in PSD Label	Defined in PSD Configuration	Control Register Setting	Direction Register Setting	VM Register Setting	JTAG Enable
MCU I/O	Declare pins only	N/A ¹	0	1 = output, 0 = input (Note ²)	N/A	N/A
PLD I/O	Logic equations	N/A	N/A	(Note ²)	N/A	N/A
Data Port (Port A)	N/A	Specify bus type	N/A	N/A	N/A	N/A
Address Out (Port A,B)	Declare pins only	N/A	1	1 (Note ²)	N/A	N/A
Address In (Port A,B,C,D)	Logic for equation Input Macrocells	N/A	N/A	N/A	N/A	N/A
Peripheral I/O (Port A)	Logic equations (PSEL0 & 1)	N/A	N/A	N/A	PIO Bit = 1	N/A
JTAG ISP (Note ³)	JTAGSEL	JTAG Configuration	N/A	N/A	N/A	JTAG_Enable

Note: 1. N/A = Not Applicable

2. The direction of the Port A,B,C, and D pins are controlled by the Direction Register OR'ed with the individual output enable product term (.oe) from the CPLD AND Array.

3. Any of these three methods enables the JTAG pins on Port C.

Table 20. I/O Port Latched Address Output Assignments

MCU	Port A (PA3-PA0)	Port A (PA7-PA4)	Port B (PB3-PB0)	Port B (PB7-PB4)
8051XA (8-bit)	N/A ¹	Address a7-a4	Address a11-a8	N/A
80C251 (Page Mode)	N/A	N/A	Address a11-a8	Address a15-a12
All Other 8-bit Multiplexed	Address a3-a0	Address a7-a4	Address a3-a0	Address a7-a4
8-bit Non-Multiplexed Bus	N/A	N/A	Address a3-a0	Address a7-a4

Note: 1. N/A = Not Applicable.

Address In Mode

For MCUs that have more than 16 address signals, the higher addresses can be connected to Port A, B, C, and D. The address input can be latched in the Input Macrocell (IMC) by Address Strobe (ALE/AS, PD0). Any input that is included in the DPLD equations for the SRAM, or primary or secondary Flash memory is considered to be an address input.

Data Port Mode

Port A can be used as a data bus port for a MCU with a non-multiplexed address/data bus. The Data Port is connected to the data bus of the MCU. The general I/O functions are disabled in Port A if the port is configured as a Data Port.

Peripheral I/O Mode

Peripheral I/O mode can be used to interface with external peripherals. In this mode, all of Port A

serves as a tri-state, bi-directional data buffer for the MCU. Peripheral I/O Mode is enabled by setting Bit 7 of the VM Register to a 1. Figure 23 shows how Port A acts as a bi-directional buffer for the MCU data bus if Peripheral I/O Mode is enabled. An equation for PSEL0 and/or PSEL1 must be written in PSDLabel. The buffer is tri-stated when PSEL0 or PSEL1 is not active.

JTAG In-System Programming (ISP)

Port C is JTAG compliant, and can be used for In-System Programming (ISP). You can multiplex JTAG operations with other functions on Port C because In-System Programming (ISP) is not performed in normal Operating mode. For more information on the JTAG Port, see the section entitled "PROGRAMMING IN-CIRCUIT USING THE JTAG SERIAL INTERFACE", on page 63.

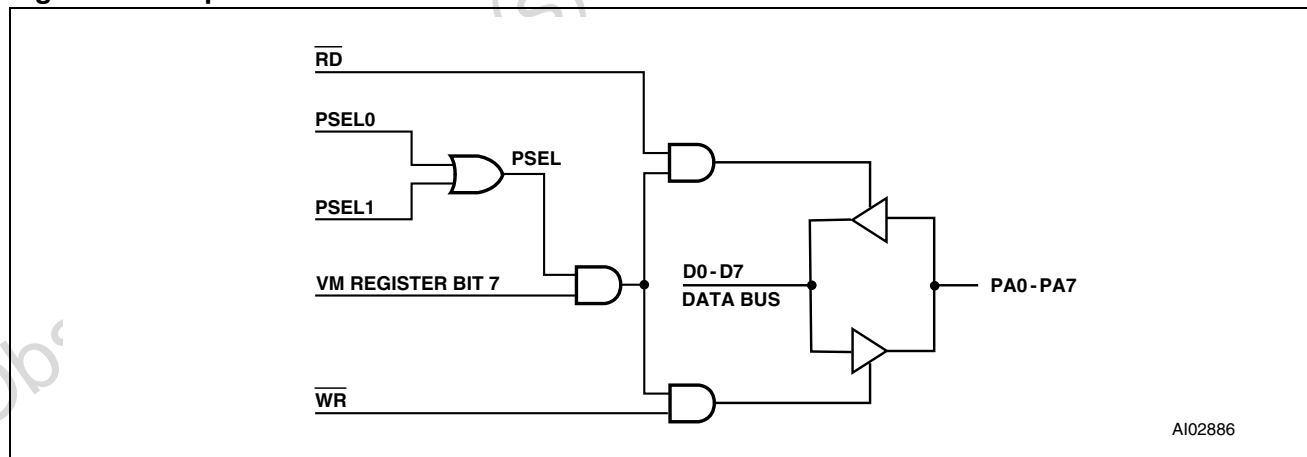
Figure 23. Peripheral I/O Mode

Port Configuration Registers (PCR)

Each Port has a set of Port Configuration Registers (PCR) used for configuration. The contents of the registers can be accessed by the MCU through normal READ/WRITE bus cycles at the addresses given in Table 6. The addresses in Table 6 are the offsets in hexadecimal from the base of the CSIOP register.

The pins of a port are individually configurable and each bit in the register controls its respective pin. For example, Bit 0 in a register refers to Bit 0 of its port. The three Port Configuration Registers (PCR), shown in Table 21, are used for setting the Port configurations. The default Power-up state for each register in Table 21 is 00h.

Control Register. Any bit reset to '0' in the Control Register sets the corresponding port pin to MCU I/O Mode, and a 1 sets it to Address Out Mode. The default mode is MCU I/O. Only Ports A and B have an associated Control Register.

Direction Register. The Direction Register, in conjunction with the output enable (except for Port D), controls the direction of data flow in the I/O Ports. Any bit set to '1' in the Direction Register causes the corresponding pin to be an output, and any bit set to '0' causes it to be an input. The default mode for all port pins is input.

Figure 24 and Figure 25 show the Port Architecture diagrams for Ports A/B and C, respectively. The direction of data flow for Ports A, B, and C are controlled not only by the direction register, but also by the output enable product term from the PLD AND Array. If the output enable product term is not active, the Direction Register has sole control of a given pin's direction.

An example of a configuration for a Port with the three least significant bits set to output and the remainder set to input is shown in Table 24. Since Port D only contains three pins (shown in Figure 27), the Direction Register for Port D has only the three least significant bits active.

Drive Select Register. The Drive Select Register configures the pin driver as Open Drain or CMOS for some port pins, and controls the slew rate for the other port pins. An external pull-up resistor should be used for pins configured as Open Drain.

A pin can be configured as Open Drain if its corresponding bit in the Drive Select Register is set to a 1. The default pin drive is CMOS.

Note that the slew rate is a measurement of the rise and fall times of an output. A higher slew rate means a faster output response and may create more electrical noise. A pin operates in a high slew rate when the corresponding bit in the Drive Register is set to '1.' The default rate is slow slew.

Table 25 shows the Drive Register for Ports A, B, C, and D. It summarizes which pins can be configured as Open Drain outputs and which pins the slew rate can be set for.

Table 21. Port Configuration Registers (PCR)

Register Name	Port	MCU Access
Control	A,B	WRITE/READ
Direction	A,B,C,D	WRITE/READ
Drive Select ¹	A,B,C,D	WRITE/READ

Note: 1. See Table 25 for Drive Register bit definition.

Table 22. Port Pin Direction Control, Output Enable P.T. Not Defined

Direction Register Bit	Port Pin Mode
0	Input
1	Output

Table 23. Port Pin Direction Control, Output Enable P.T. Defined

Direction Register Bit	Output Enable P.T.	Port Pin Mode
0	0	Input
0	1	Output
1	0	Output
1	1	Output

Table 24. Port Direction Assignment Example

Bit 7	Bit 6	Bit 5	Bit 4	Bit 3	Bit 2	Bit 1	Bit 0
0	0	0	0	0	1	1	1

Table 25. Drive Register Pin Assignment

Drive Register	Bit 7	Bit 6	Bit 5	Bit 4	Bit 3	Bit 2	Bit 1	Bit 0
Port A	Open Drain	Open Drain	Open Drain	Open Drain	Slew Rate	Slew Rate	Slew Rate	Slew Rate
Port B	Open Drain	Open Drain	Open Drain	Open Drain	Slew Rate	Slew Rate	Slew Rate	Slew Rate
Port C	Open Drain	Open Drain	Open Drain	Open Drain	Open Drain	Open Drain	Open Drain	Open Drain
Port D	NA ¹	NA ¹	NA ¹	NA ¹	NA ¹	Slew Rate	Slew Rate	Slew Rate

Note: 1. NA = Not Applicable.

Port Data Registers

The Port Data Registers, shown in Table 26, are used by the MCU to write data to or read data from the ports. Table 26 shows the register name, the ports having each register type, and MCU access for each register type. The registers are described below.

Data In. Port pins are connected directly to the Data In buffer. In MCU I/O input mode, the pin input is read through the Data In buffer.

Data Out Register. Stores output data written by the MCU in the MCU I/O output mode. The contents of the Register are driven out to the pins if the Direction Register or the output enable product term is set to 1. The contents of the register can also be read back by the MCU.

Output Macrocells (OMC). The CPLD Output Macrocells (OMC) occupy a location in the MCU's address space. The MCU can read the output of the Output Macrocells (OMC). If the OMC Mask Register bits are not set, writing to the macrocell

loads data to the macrocell flip-flops. See the section entitled "PLDS", on page 27.

OMC Mask Register. Each OMC Mask Register bit corresponds to an Output Macrocell (OMC) flip-flop. When the OMC Mask Register bit is set to a '1,' loading data into the Output Macrocell (OMC) flip-flop is blocked. The default value is 0 or unblocked.

Input Macrocells (IMC). The Input Macrocells (IMC) can be used to latch or store external inputs. The outputs of the Input Macrocells (IMC) are routed to the PLD input bus, and can be read by the MCU. See the section entitled "PLDS", on page 27.

Enable Out. The Enable Out register can be read by the MCU. It contains the output enable values for a given port. A 1 indicates the driver is in output mode. A 0 indicates the driver is in tri-state and the pin is in input mode.

Table 26. Port Data Registers

Register Name	Port	MCU Access
Data In	A,B,C,D	READ – input on pin
Data Out	A,B,C,D	WRITE/READ
Output Macrocell	A,B,C	READ – outputs of macrocells WRITE – loading macrocells flip-flop
Mask Macrocell	A,B,C	WRITE/READ – prevents loading into a given macrocell
Input Macrocell	A,B,C	READ – outputs of the Input Macrocells
Enable Out	A,B,C	READ – the output enable control of the port driver

Ports A and B – Functionality and Structure

Ports A and B have similar functionality and structure, as shown in Figure 24. The two ports can be configured to perform one or more of the following functions:

- MCU I/O Mode
- CPLD Output – Macrocells McellAB7-McellAB0 can be connected to Port A or Port B. McellBC7-McellBC0 can be connected to Port B or Port C.
- CPLD Input – Via the Input Macrocells (IMC).
- Latched Address output – Provide latched address output as per Table 20.
- Address In – Additional high address inputs using the Input Macrocells (IMC).
- Open Drain/Slew Rate – pins PA3-PA0 and PB3-PB0 can be configured to fast slew rate, pins PA7-PA4 and PB7-PB4 can be configured to Open Drain Mode.
- Data Port – Port A to D7-D0 for 8-bit, non-multiplexed bus
- Multiplexed Address/Data port for certain types of MCU bus interfaces.
- Peripheral Mode – Port A only

Figure 24. Port A and Port B Structure

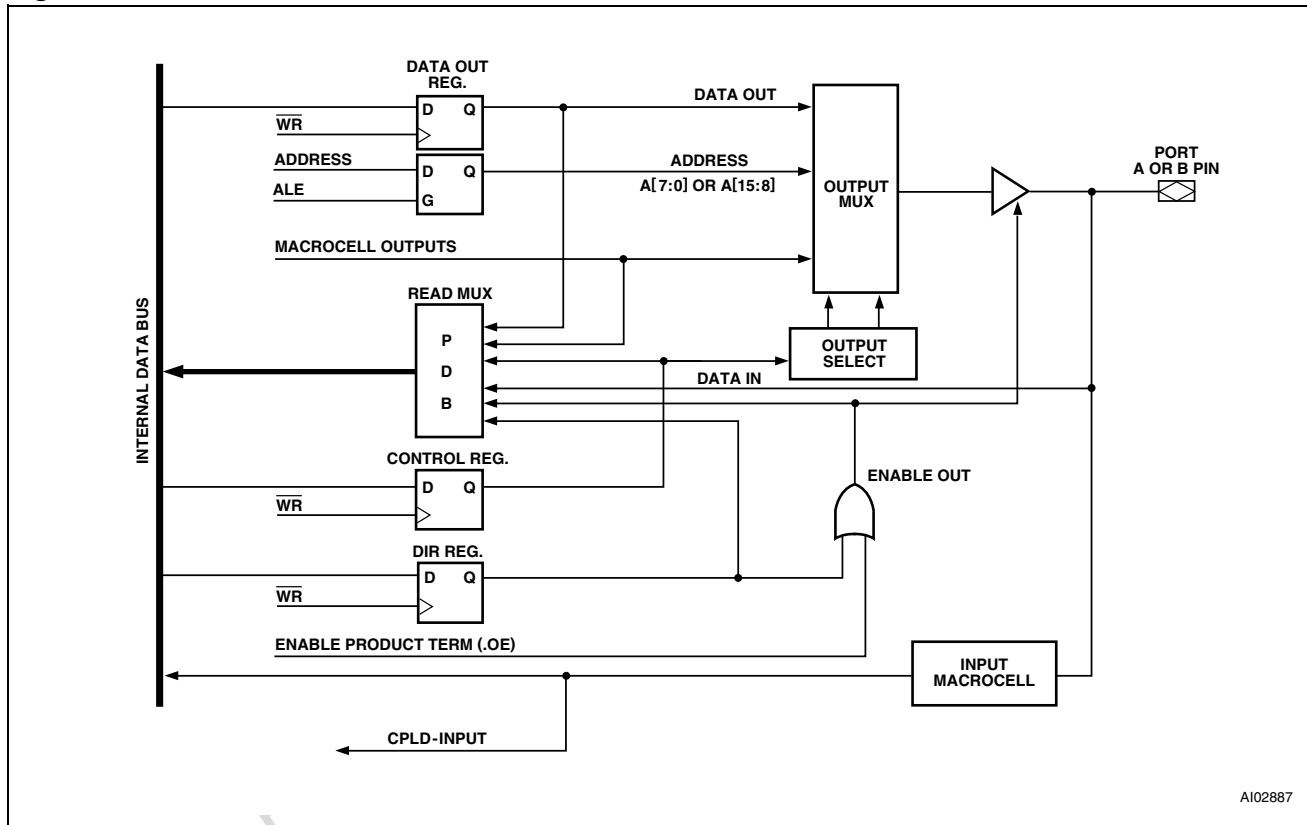

A102887

Obsolete

Port C – Functionality and Structure

Port C can be configured to perform one or more of the following functions (see Figure 25):

- MCU I/O Mode
- CPLD Output – McellIBC7-McellIBC0 outputs can be connected to Port B or Port C.
- CPLD Input – via the Input Macrocells (IMC)
- Address In – Additional high address inputs using the Input Macrocells (IMC).
- In-System Programming (ISP) – JTAG port can be enabled for programming/erase of the PSD

device. (See the section entitled “PROGRAMMING IN-CIRCUIT USING THE JTAG SERIAL INTERFACE”, on page 63, for more information on JTAG programming.)

- Open Drain – Port C pins can be configured in Open Drain Mode

Port C does not support Address Out mode, and therefore no Control Register is required.

Pin PC7 may be configured as the DBE input in certain MCU bus interfaces.

Figure 25. Port C Structure

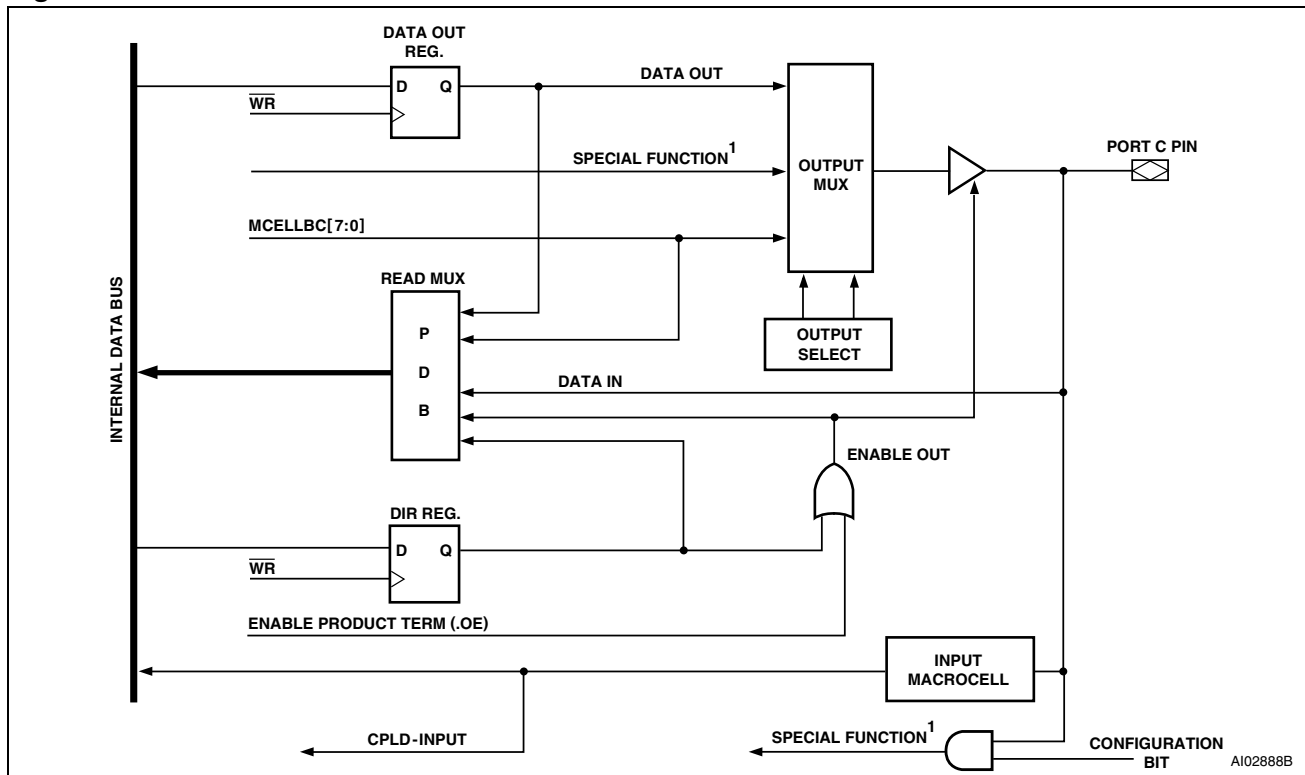

Port D – Functionality and Structure

Port D has three I/O pins. See Figure 26 and Figure 27. This port does not support Address Out mode, and therefore no Control Register is required. Port D can be configured to perform one or more of the following functions:

- MCU I/O Mode
- CPLD Output – External Chip Select (ECS0-ECS2)
- CPLD Input – direct input to the CPLD, no Input Macrocells (IMC)

- Slew rate – pins can be set up for fast slew rate
- Port D pins can be configured in PSDsoft Express as input pins for other dedicated functions:
- Address Strobe (ALE/AS, PD0)
 - CLKIN (PD1) as input to the macrocells flip-flops and APD counter
 - PSD Chip Select Input ($\overline{\text{CSI}}$, PD2). Driving this signal High disables the Flash memory, SRAM and CSIOP.

Figure 26. Port D Structure

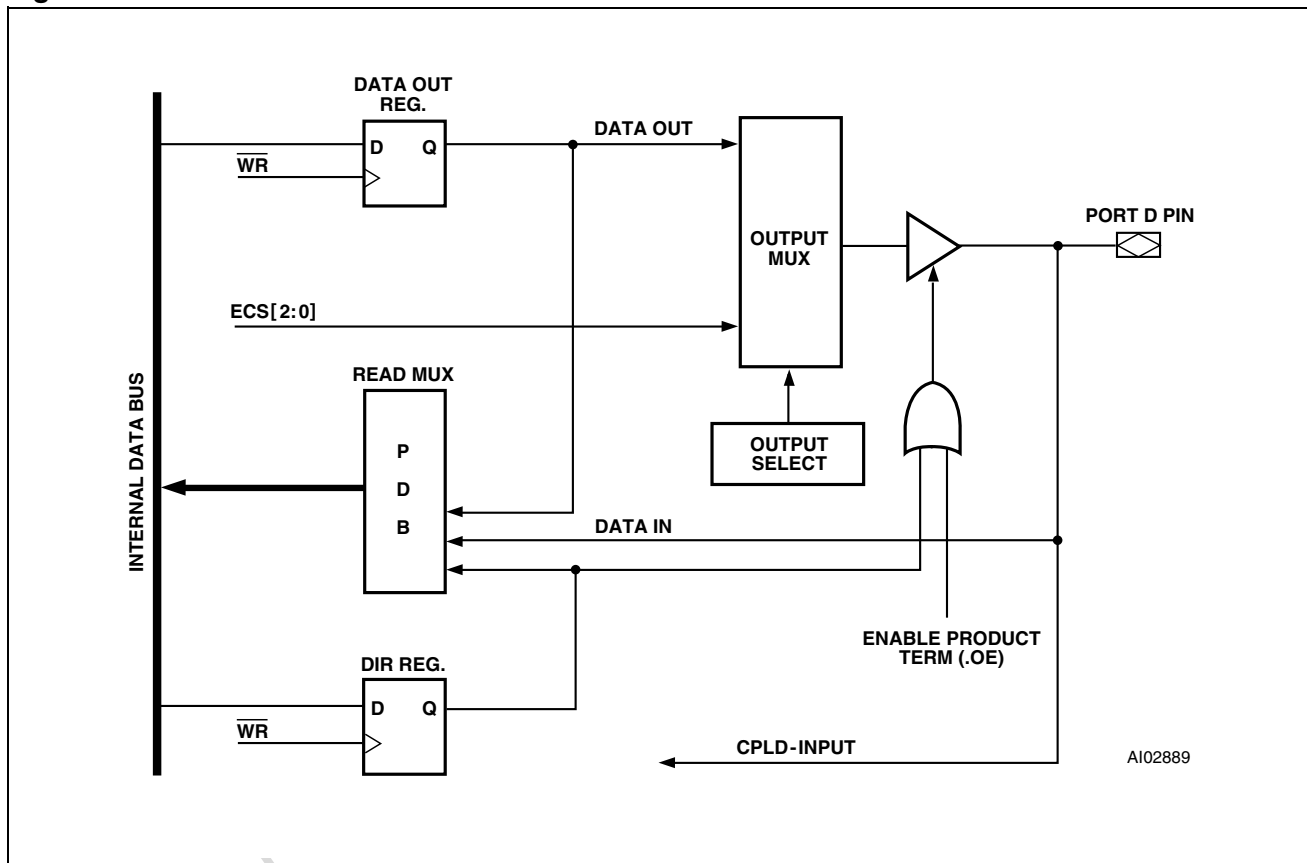

Obsolete

External Chip Select

The CPLD also provides three External Chip Select (ECS0-ECS2) outputs on Port D pins that can be used to select external devices. Each External Chip Select (ECS0-ECS2) consists of one product

term that can be configured active High or Low. The output enable of the pin is controlled by either the output enable product term or the Direction Register. (See Figure 27.)

Figure 27. Port D External Chip Select Signals

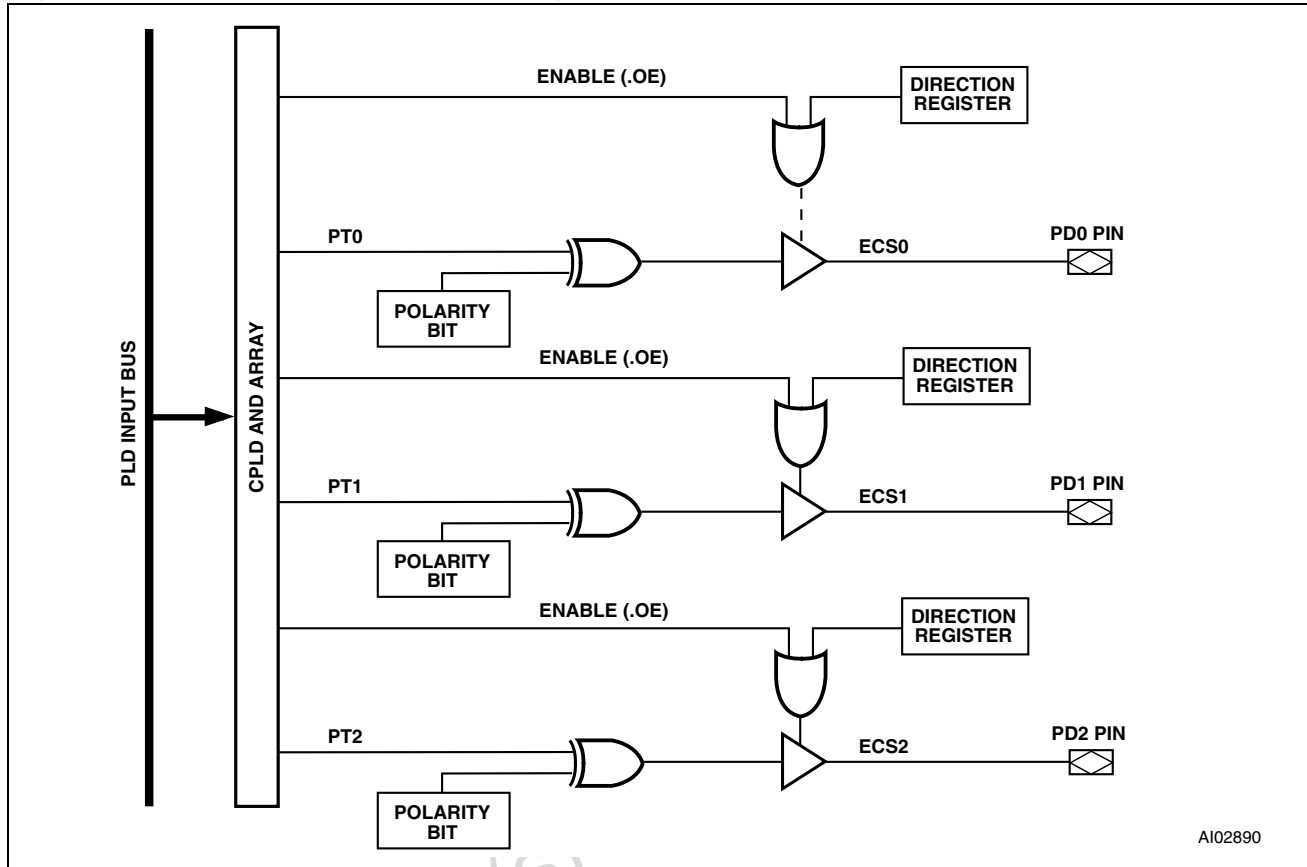

Obsolete Product(s)

POWER MANAGEMENT

All PSD devices offer configurable power saving options. These options may be used individually or in combinations, as follows:

- All memory blocks in a PSD (primary and secondary Flash memory, and SRAM) are built with power management technology. In addition to using special silicon design methodology, power management technology puts the memories into standby mode when address/data inputs are not changing (zero DC current). As soon as a transition occurs on an input, the affected memory “wakes up”, changes and latches its outputs, then goes back to standby. The designer does *not* have to do anything special to achieve memory standby mode when no inputs are changing—it happens automatically.

the pld sections can also achieve standby mode when its inputs are not changing, as described in the sections on the Power Management Mode Registers (PMMR).

- As with the Power Management mode, the Automatic Power Down (APD) block allows the PSD to reduce to standby current automatically. The APD Unit can also block MCU address/data signals from reaching the memories and PLDs. This feature is available on all the devices of the PSD family. The APD Unit is described in more detail in the sections entitled “Automatic Power-down (APD) Unit and Power-down Mode”, on page 57.

Built in logic monitors the Address Strobe of the MCU for activity. If there is no activity for a certain time period (MCU is asleep), the APD Unit initiates Power-down mode (if enabled). Once in Power-down mode, all address/data signals are blocked from reaching PSD memory and PLDs, and the memories are deselected

internally. This allows the memory and PLDs to remain in standby mode even if the address/data signals are changing state externally (noise, other devices on the MCU bus, etc.). Keep in mind that any unblocked PLD input signals that are changing states keeps the PLD out of standby mode, but not the memories.

- PSD Chip Select Input ($\overline{CS1}$, PD2) can be used to disable the internal memories, placing them in standby mode even if inputs are changing. This feature does not block any internal signals or disable the PLDs. This is a good alternative to using the APD Unit. There is a slight penalty in memory access time when PSD Chip Select Input (CS1, PD2) makes its initial transition from deselected to selected.
- The PMMRs can be written by the MCU at run-time to manage power. All PSD supports “blocking bits” in these registers that are set to block designated signals from reaching both PLDs. Current consumption of the PLDs is directly related to the composite frequency of the changes on their inputs (see Figure 31). Significant power savings can be achieved by blocking signals that are not used in DPLD or CPLD logic equations.

PSD devices have a Turbo bit in PMMR0. This bit can be set to turn the Turbo mode off (the default is with Turbo mode turned on). While Turbo mode is off, the PLDs can achieve standby current when no PLD inputs are changing (zero DC current). Even when inputs do change, significant power can be saved at lower frequencies (AC current), compared to when Turbo mode is on. When the Turbo mode is on, there is a significant DC current component and the AC component is higher.

Automatic Power-down (APD) Unit and Power-down Mode. The APD Unit, shown in Figure 28, puts the PSD into Power-down mode by monitoring the activity of Address Strobe (ALE/AS, PD0). If the APD Unit is enabled, as soon as activity on Address Strobe (ALE/AS, PD0) stops, a 4-bit counter starts counting. If Address Strobe (ALE/AS, PD0) remains inactive for fifteen clock periods of CLKIN (PD1), Power-down (PDN) goes High, and the PSD enters Power-down mode, as discussed next.

Power-down Mode. By default, if you enable the APD Unit, Power-down mode is automatically enabled. The device enters Power-down mode if Address Strobe (ALE/AS, PD0) remains inactive for fifteen periods of CLKIN (PD1).

The following should be kept in mind when the PSD is in Power-down mode:

- If Address Strobe (ALE/AS, PD0) starts pulsing again, the PSD returns to normal Operating mode. The PSD also returns to normal Operating mode if either PSD Chip Select Input (CSI, PD2) is Low or the Reset (RESET) input is High.
- The MCU address/data bus is blocked from all memory and PLDs.
- Various signals can be blocked (prior to Power-down mode) from entering the PLDs by setting

the appropriate bits in the PMMR registers. The blocked signals include MCU control signals and the common CLKIN (PD1). Note that blocking CLKIN (PD1) from the PLDs does not block CLKIN (PD1) from the APD Unit.

- All PSD memories enter Standby mode and are drawing standby current. However, the PLD and I/O ports blocks do *not* go into Standby Mode because you don't want to have to wait for the logic and I/O to "wake-up" before their outputs can change. See Table 27 for Power-down mode effects on PSD ports.
- Typical standby current is of the order of microamperes. These standby current values assume that there are no transitions on any PLD input.

Table 27. Power-down Mode's Effect on Ports

Port Function	Pin Level
MCU I/O	No Change
PLD Out	No Change
Address Out	Undefined
Data Port	Tri-State
Peripheral I/O	Tri-State

Figure 28. APD Unit

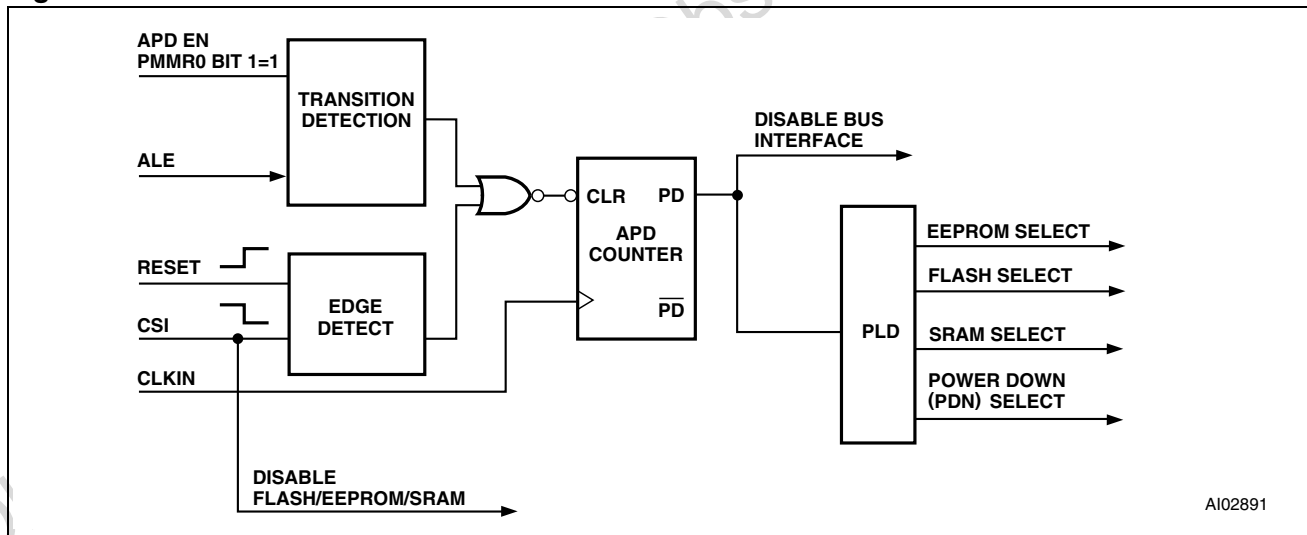

Table 28. PSD Timing and Standby Current during Power-down Mode

Mode	PLD Propagation Delay	Memory Access Time	Access Recovery Time to Normal Access	Typical Standby Current
Power-down	Normal t_{PD} (Note ¹)	No Access	t_{LVDV}	25 μ A (Note ²)

Note: 1. Power-down does not affect the operation of the PLD. The PLD operation in this mode is based only on the Turbo Bit.
 2. Typical current consumption assuming no PLD inputs are changing state and the PLD Turbo Bit is '0.'

For Users of the HC11 (or compatible). The HC11 turns off its E clock when it sleeps. Therefore, if you are using an HC11 (or compatible) in your design, and you wish to use the Power-down mode, you must not connect the E clock to CLKIN (PD1). You should instead connect a crystal oscillator to CLKIN (PD1). The crystal oscillator frequency must be *less than* 15 times the frequency of AS. The reason for this is that if the frequency is greater than 15 times the frequency of AS, the PSD keeps going into Power-down mode.

Other Power Saving Options. The PSD offers other reduced power saving options that are independent of the Power-down mode. Except for the PSD Chip Select Input (CSI, PD2) feature, they are enabled by setting bits in PMMR0 and PMMR2.

Figure 29. Enable Power-down Flow Chart

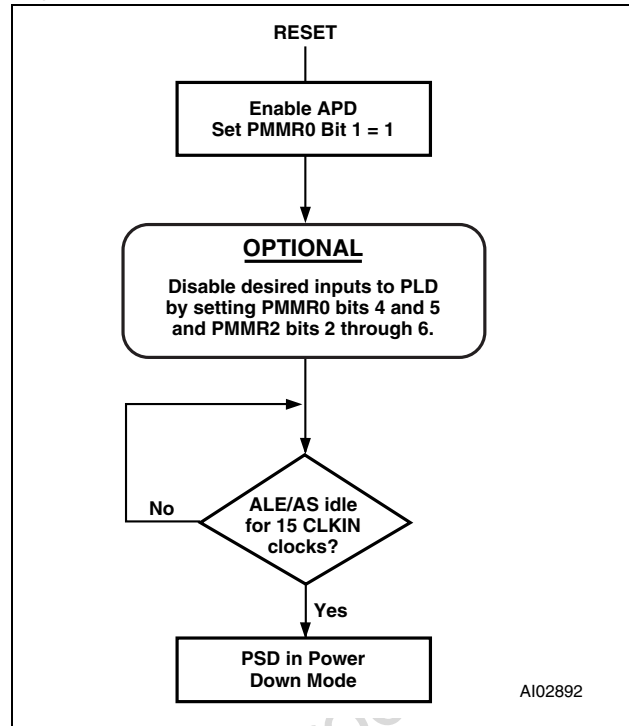

Obsolete Product(s) - Obsolete Product

PLD Power Management

The power and speed of the PLDs are controlled by the Turbo Bit (Bit 3) in PMMR0. By setting the bit to '1,' the Turbo mode is off and the PLDs consume the specified standby current when the inputs are not switching for an extended time of 70ns. The propagation delay time is increased by 10ns after the Turbo Bit is set to '1' (turned off) when the inputs change at a composite frequency

of less than 15 MHz. When the Turbo Bit is reset to '0' (turned on), the PLDs run at full power and speed. The Turbo Bit affects the PLD's DC power, AC power, and propagation delay.

Blocking MCU control signals with the bits of PMMR2 can further reduce PLD AC power consumption.

Table 29. Power Management Mode Registers PMMR0 (Note 1)

Bit 0	X	0	Not used, and should be set to zero.
Bit 1	APD Enable	0 = off	Automatic Power-down (APD) is disabled.
		1 = on	Automatic Power-down (APD) is enabled.
Bit 2	X	0	Not used, and should be set to zero.
Bit 3	PLD Turbo	0 = on	PLD Turbo mode is on
		1 = off	PLD Turbo mode is off, saving power.
Bit 4	PLD Array clk	0 = on	CLKIN (PD1) input to the PLD AND Array is connected. Every change of CLKIN (PD1) Powers-up the PLD when Turbo bit is 0.
		1 = off	CLKIN (PD1) input to PLD AND Array is disconnected, saving power.
Bit 5	PLD MCell clk	0 = on	CLKIN (PD1) input to the PLD macrocells is connected.
		1 = off	CLKIN (PD1) input to PLD macrocells is disconnected, saving power.
Bit 6	X	0	Not used, and should be set to zero.
Bit 7	X	0	Not used, and should be set to zero.

Table 30. Power Management Mode Registers PMMR2 (Note 1)

Bit 0	X	0	Not used, and should be set to zero.
Bit 1	X	0	Not used, and should be set to zero.
Bit 2	PLD Array CNTL0	0 = on	CntI0 input to the PLD AND Array is connected.
		1 = off	CntI0 input to PLD AND Array is disconnected, saving power.
Bit 3	PLD Array CNTL1	0 = on	CntI1 input to the PLD AND Array is connected.
		1 = off	CntI1 input to PLD AND Array is disconnected, saving power.
Bit 4	PLD Array CNTL2	0 = on	CntI2 input to the PLD AND Array is connected.
		1 = off	CntI2 input to PLD AND Array is disconnected, saving power.
Bit 5	PLD Array ALE	0 = on	ALE input to the PLD AND Array is connected.
		1 = off	ALE input to PLD AND Array is disconnected, saving power.
Bit 6	PLD Array DBE	0 = on	DBE input to the PLD AND Array is connected.
		1 = off	DBE input to PLD AND Array is disconnected, saving power.
Bit 7	X	0	Not used, and should be set to zero.

Note: 1. The bits of this register are cleared to zero following Power-up. Subsequent Reset ($\overline{\text{Reset}}$) pulses do not clear the registers.

PSD Chip Select Input ($\overline{\text{CSI}}$, PD2)

PD2 of Port D can be configured in PSDsoft Express as PSD Chip Select Input ($\overline{\text{CSI}}$). When Low, the signal selects and enables the internal Flash memory, EEPROM, SRAM, and I/O blocks for READ or WRITE operations involving the PSD. A High on PSD Chip Select Input ($\overline{\text{CSI}}$, PD2) disables the Flash memory, EEPROM, and SRAM, and reduces the PSD power consumption. However, the PLD and I/O signals remain operational when PSD Chip Select Input ($\overline{\text{CSI}}$, PD2) is High.

There may be a timing penalty when using PSD Chip Select Input ($\overline{\text{CSI}}$, PD2) depending on the speed grade of the PSD that you are using. See the timing parameter t_{SLQV} in Table 50.

Input Clock

The PSD provides the option to turn off CLKIN (PD1) to the PLD to save AC power consumption.

CLKIN (PD1) is an input to the PLD AND Array and the Output Macrocells (OMC).

During Power-down mode, or, if CLKIN (PD1) is not being used as part of the PLD logic equation, the clock should be disabled to save AC power. CLKIN (PD1) is disconnected from the PLD AND Array or the Macrocells block by setting Bits 4 or 5 to a '1' in PMMR0.

Input Control Signals

The PSD provides the option to turn off the input control signals (CNTL0, CNTL1, CNTL2, Address Strobe (ALE/AS, PD0) and DBE) to the PLD to save AC power consumption. These control signals are inputs to the PLD AND Array. During Power-down mode, or, if any of them are not being used as part of the PLD logic equation, these control signals should be disabled to save AC power. They are disconnected from the PLD AND Array by setting Bits 2, 3, 4, 5, and 6 to a 1 in PMMR2.

Table 31. APD Counter Operation

APD Enable Bit	ALE PD Polarity	ALE Level	APD Counter
0	X	X	Not Counting
1	X	Pulsing	Not Counting
1	1	1	Counting (Generates PDN after 15 Clocks)
1	0	0	Counting (Generates PDN after 15 Clocks)

RESET TIMING AND DEVICE STATUS AT RESET

Upon Power-up, the PSD requires a Reset ($\overline{\text{RESET}}$) pulse of duration $t_{\text{NLNH-PO}}$ after V_{CC} is steady. During this period, the device loads internal configurations, clears some of the registers and sets the Flash memory into Operating mode. After the rising edge of Reset ($\overline{\text{RESET}}$), the PSD remains in the Reset mode for an additional period, t_{OPR} , before the first memory access is allowed.

The Flash memory is reset to the READ Mode upon Power-up. Sector Select (FS0-FS7 and CSBOOT0-CSBOOT3) must all be Low, Write Strobe ($\overline{\text{WR}}$, CNTL0) High, during Power On Reset for maximum security of the data contents and to remove the possibility of a byte being written on the first edge of Write Strobe ($\overline{\text{WR}}$, CNTL0). Any Flash memory WRITE cycle initiation is prevented automatically when V_{CC} is below V_{LKO} .

Warm Reset

Once the device is up and running, the device can be reset with a pulse of a much shorter duration,

t_{NLNH} . The same t_{OPR} period is needed before the device is operational after warm reset. Figure 30 shows the timing of the Power-up and warm reset.

I/O Pin, Register and PLD Status at Reset

Table 32 shows the I/O pin, register and PLD status during Power On Reset, warm reset and Power-down mode. PLD outputs are always valid during warm reset, and they are valid in Power On Reset once the internal PSD Configuration bits are loaded. This loading of PSD is completed typically long before the V_{CC} ramps up to operating level. Once the PLD is active, the state of the outputs are determined by the PSD label equations.

Reset of Flash Memory Erase and Program Cycles

A Reset ($\overline{\text{RESET}}$) also resets the internal Flash memory state machine. During a Flash memory Program or Erase cycle, Reset ($\overline{\text{RESET}}$) terminates the cycle and returns the Flash memory to the READ Mode within a period of $t_{\text{NLNH-A}}$.

Figure 30. Reset ($\overline{\text{RESET}}$) Timing

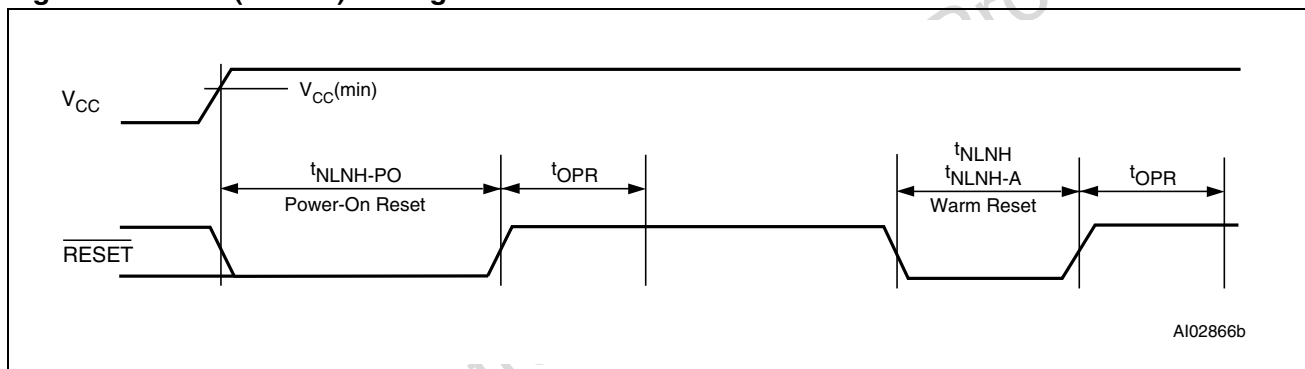

Table 32. Status During Power-On Reset, Warm Reset and Power-down Mode

Port Configuration	Power-On Reset	Warm Reset	Power-down Mode
MCU I/O	Input mode	Input mode	Unchanged
PLD Output	Valid after internal PSD configuration bits are loaded	Valid	Depends on inputs to PLD (addresses are blocked in PD mode)
Address Out	Tri-stated	Tri-stated	Not defined
Data Port	Tri-stated	Tri-stated	Tri-stated
Peripheral I/O	Tri-stated	Tri-stated	Tri-stated

Register	Power-On Reset	Warm Reset	Power-down Mode
PMMR0 and PMMR2	Cleared to 0	Unchanged	Unchanged
Macrocells flip-flop status	Cleared to 0 by internal Power-On Reset	Depends on .re and .pr equations	Depends on .re and .pr equations
VM Register ¹	Initialized, based on the selection in PSDsoft Configuration menu	Initialized, based on the selection in PSDsoft Configuration menu	Unchanged
All other registers	Cleared to 0	Cleared to 0	Unchanged

Note: 1. The SR_cod and PeriphMode Bits in the VM Register are always cleared to 0 on Power-On Reset or Warm Reset.

PROGRAMMING IN-CIRCUIT USING THE JTAG SERIAL INTERFACE

The JTAG Serial Interface block can be enabled on Port C (see Table 33). All memory blocks (primary and secondary Flash memory), PLD logic, and PSD Configuration Register bits may be programmed through the JTAG Serial Interface block. A blank device can be mounted on a printed circuit board and programmed using JTAG.

The standard JTAG signals (IEEE 1149.1) are TMS, TCK, TDI, and TDO. Two additional signals, TSTAT and TERR, are optional JTAG extensions used to speed up Program and Erase cycles.

By default, on a blank PSD (as shipped from the factory or after erasure), four pins on Port C are enabled for the basic JTAG signals TMS, TCK, TDI, and TDO.

See Application Note AN1153 for more details on JTAG In-System Programming (ISP).

Standard JTAG Signals

The standard JTAG signals (TMS, TCK, TDI, and TDO) can be enabled by any of three different conditions that are logically OR'ed. When enabled, TDI, TDO, TCK, and TMS are inputs, waiting for a JTAG serial command from an external JTAG controller device (such as FlashLINK or Automated Test Equipment). When the enabling command is received, TDO becomes an output and the JTAG channel is fully functional inside the PSD. The same command that enables the JTAG channel may optionally enable the two additional JTAG signals, TSTAT and TERR.

The following symbolic logic equation specifies the conditions enabling the four basic JTAG signals (TMS, TCK, TDI, and TDO) on their respective Port C pins. For purposes of discussion, the logic label JTAG_ON is used. When JTAG_ON is true, the four pins are enabled for JTAG. When JTAG_ON is false, the four pins can be used for general PSD I/O.

```
JTAG_ON = PSDsoft_enabled +
/* An NVM configuration bit inside the
PSD is set by the designer in the
PSDsoft Express Configuration utility.
This dedicates the pins for JTAG at all
times (compliant with IEEE 1149.1 */
Microcontroller_enabled +
/* The microcontroller can set a bit at
run-time by writing to the PSD
register, JTAG Enable. This register
```

```
is located at address CSIOP + offset
C7h. Setting the JTAG_ENABLE bit in
this register will enable the pins for
JTAG use. This bit is cleared by a PSD
reset or the microcontroller. See
Table 34 for bit definition. */
```

```
PSD_product_term_enabled;
/* A dedicated product term (PT) inside
the PSD can be used to enable the JTAG
pins. This PT has the reserved name
JTAGSEL. Once defined as a node in
PSDabel, the designer can write an
equation for JTAGSEL. This method is
used when the Port C JTAG pins are
multiplexed with other I/O signals. It
is recommended to logically tie the
node JTAGSEL to the JEN\ signal on the
Flashlink cable when multiplexing JTAG
signals. See Application Note 1153 for
details. */
```

The state of the PSD Reset (RESET) signal does not interrupt (or prevent) JTAG operations if the JTAG pins are dedicated by an NVM configuration bit (via PSDsoft Express). However, Reset (RESET) will prevent or interrupt JTAG operations if the JTAG enable register is used to enable the JTAG pins.

The PSD supports JTAG In-System-Configuration (ISC) commands, but not Boundary Scan. The PSDsoft Express software tool and FlashLINK JTAG programming cable implement the JTAG In-System-Configuration (ISC) commands. A definition of these JTAG In-System-Configuration (ISC) commands and sequences is defined in a supplemental document available from ST. This document is needed only as a reference for designers who use a FlashLINK to program their PSD.

Table 33. JTAG Port Signals

Port C Pin	JTAG Signals	Description
PC0	TMS	Mode Select
PC1	TCK	Clock
PC3	<u>TSTAT</u>	Status
PC4	<u>TERR</u>	Error Flag
PC5	TDI	Serial Data In
PC6	TDO	Serial Data Out

JTAG Extensions

\overline{TSTAT} and \overline{TERR} are two JTAG extension signals enabled by an "ISC_ENABLE" command received over the four standard JTAG signals (TMS, TCK, TDI, and TDO). They are used to speed Program and Erase cycles by indicating status on PSD signals instead of having to scan the status out serially using the standard JTAG channel. See Application Note AN1153.

\overline{TERR} indicates if an error has occurred when erasing a sector or programming a byte in Flash memory. This signal goes Low (active) when an Error condition occurs, and stays Low until an "ISC_CLEAR" command is executed or a chip Reset (\overline{RESET}) pulse is received after an "ISC_DISABLE" command.

\overline{TSTAT} behaves the same as Ready/Busy described in the section entitled "Ready/Busy (PC3)", on page 15. \overline{TSTAT} is High when the PSD device is in READ Mode (primary and secondary Flash memory contents can be read). \overline{TSTAT} is Low when Flash memory Program or Erase cycles are in progress, and also when data is being written to the secondary Flash memory.

\overline{TSTAT} and \overline{TERR} can be configured as open-drain type signals during an "ISC_ENABLE" command. This facilitates a wired-OR connection of \overline{TSTAT} signals from multiple PSD devices and a wired-OR connection of \overline{TERR} signals from those

same devices. This is useful when several PSD devices are "chained" together in a JTAG environment.

Security and Flash memory Protection

When the security bit is set, the device cannot be read on a Device Programmer or through the JTAG Port. When using the JTAG Port, only a Full Chip Erase command is allowed.

All other Program, Erase and Verify commands are blocked. Full Chip Erase returns the part to a non-secured blank state. The Security Bit can be set in PSDsoft Express Configuration.

All primary and secondary Flash memory sectors can individually be sector protected against erasures. The sector protect bits can be set in PSDsoft Express Configuration.

INITIAL DELIVERY STATE

When delivered from ST, the PSD device has all bits in the memory and PLDs set to '1.' The PSD Configuration Register bits are set to '0.' The code, configuration, and PLD logic are loaded using the programming procedure. Information for programming the device is available directly from ST. Please contact your local sales representative.

Table 34. JTAG Enable Register

Bit 0	JTAG_Enable	0 = off	JTAG port is disabled.
		1 = on	JTAG port is enabled.
Bit 1	X	0	Not used, and should be set to zero.
Bit 2	X	0	Not used, and should be set to zero.
Bit 3	X	0	Not used, and should be set to zero.
Bit 4	X	0	Not used, and should be set to zero.
Bit 5	X	0	Not used, and should be set to zero.
Bit 6	X	0	Not used, and should be set to zero.
Bit 7	X	0	Not used, and should be set to zero.

Note: 1. The state of Reset (\overline{Reset}) does not interrupt (or prevent) JTAG operations if the JTAG signals are dedicated by an NVM Configuration bit (via PSDsoft Express). However, Reset (\overline{Reset}) prevents or interrupts JTAG operations if the JTAG enable register is used to enable the JTAG signals.

AC/DC PARAMETERS

These tables describe the AD and DC parameters of the PSD:

- DC Electrical Specification
- AC Timing Specification
- PLD Timing
 - Combinatorial Timing
 - Synchronous Clock Mode
 - Asynchronous Clock Mode
 - Input Macrocell Timing
- MCU Timing
 - READ Timing
 - WRITE Timing
 - Peripheral Mode Timing

- Power-down and Reset Timing

The following are issues concerning the parameters presented:

- In the DC specification the supply current is given for different modes of operation. Before calculating the total power consumption, determine the percentage of time that the PSD is in each mode. Also, the supply power is considerably different if the Turbo Bit is '0.'
- The AC power component gives the PLD, Flash memory, and SRAM mA/MHz specification. Figure 31 shows the PLD mA/MHz as a function of the number of Product Terms (PT) used.
- In the PLD timing parameters, add the required delay when Turbo Bit is '0.'

Figure 31. PLD I_{CC} /Frequency Consumption

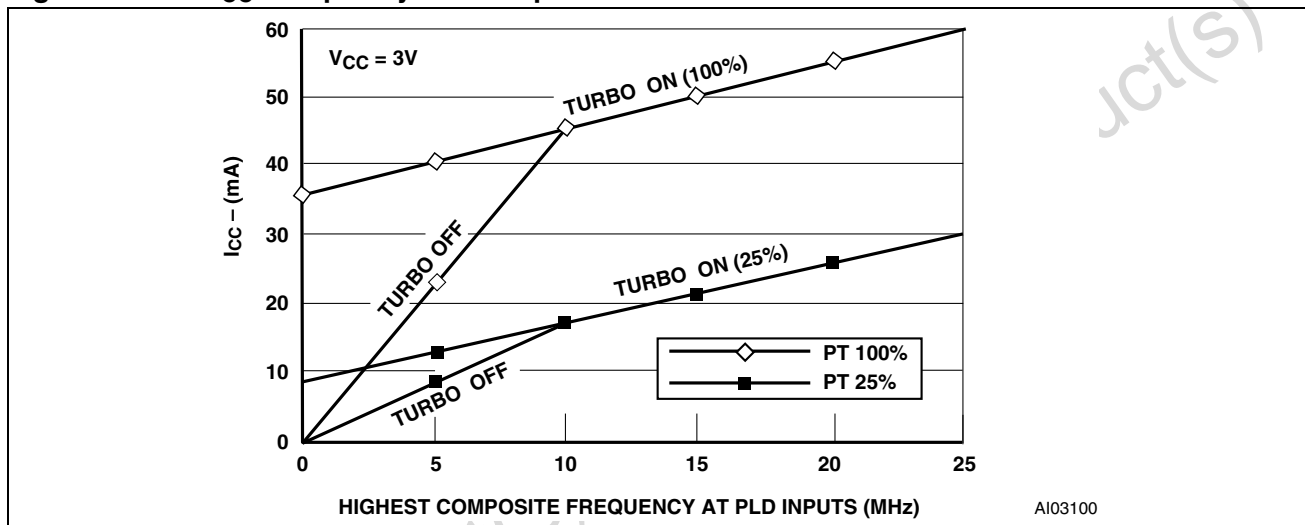

Table 35. Example of PSD Typical Power Calculation at V_{CC} = 3.3 V (with Turbo Mode On)

Conditions	
Highest Composite PLD input frequency (Freq PLD)	= 8 MHz
MCU ALE frequency (Freq ALE)	= 4 MHz
% Flash memory Access	= 80%
% SRAM access	= 15%
% I/O access	= 5% (no additional power above base)
Operational Modes	
% Normal	= 10%
% Power-down Mode	= 90%
Number of product terms used	
(from fitter report)	= 45 PT
% of total product terms	= 45/182 = 24.7%
Turbo Mode	= ON
Calculation (using typical values)	
I _{CC} total	$= I_{pwrdown} \times \%pwrdown + \%normal \times (I_{CC} (ac) + I_{CC} (dc))$ $= I_{pwrdown} \times \%pwrdown + \% normal \times (\%flash \times 1.5 \text{ mA/MHz} \times \text{Freq ALE}$ $+ \%SRAM \times 0.8 \text{ mA/MHz} \times \text{Freq ALE}$ $+ \% PLD \times 1 \text{ mA/MHz} \times \text{Freq PLD}$ $+ \#PT \times 200 \text{ } \mu\text{A/PT})$ $= 25 \text{ } \mu\text{A} \times 0.90 + 0.1 \times (0.8 \times 1.5 \text{ mA/MHz} \times 4 \text{ MHz}$ $+ 0.15 \times 0.8 \text{ mA/MHz} \times 4 \text{ MHz}$ $+ 1 \text{ mA/MHz} \times 8 \text{ MHz}$ $+ 45 \times 0.2 \text{ mA/PT})$ $= 22.5 \text{ } \mu\text{A} + 0.1 \times (4.8 + 0.48 + 8 + 9 \text{ mA})$ $= 22.5 \text{ } \mu\text{A} + 0.1 \times 22.28 \text{ mA}$ $= 22.5 \text{ } \mu\text{A} + 2.228 \text{ mA}$ $= 2.25 \text{ mA}$
<p>This is the operating power with no WRITE or Flash memory Erase cycles in progress. Calculation is based on I_{O_{UT}} = 0 mA.</p>	

Table 36. Example of PSD Typical Power Calculation at V_{CC} = 3.3 V (with Turbo Mode Off)

Conditions	
Highest Composite PLD input frequency (Freq PLD)	= 8 MHz
MCU ALE frequency (Freq ALE)	= 4 MHz
% Flash memory Access	= 80%
% SRAM access	= 15%
% I/O access	= 5% (no additional power above base)
Operational Modes	
% Normal	= 10%
% Power-down Mode	= 90%
Number of product terms used	
(from fitter report)	= 45 PT
% of total product terms	= 45/182 = 24.7%
Turbo Mode	= Off
Calculation (using typical values)	
I _{CC} total	$= I_{pwrdown} \times \%pwrdown + \%normal \times (I_{CC} (ac) + I_{CC} (dc))$ $= I_{pwrdown} \times \%pwrdown + \% normal \times (\%flash \times 1.5 \text{ mA/MHz} \times \text{Freq ALE}$ $+ \%SRAM \times 0.8 \text{ mA/MHz} \times \text{Freq ALE}$ $+ \% PLD \times (\text{from graph using Freq PLD}))$ $= 25 \mu\text{A} \times 0.90 + 0.1 \times (0.8 \times 1.5 \text{ mA/MHz} \times 4 \text{ MHz}$ $+ 0.15 \times 0.8 \text{ mA/MHz} \times 4 \text{ MHz}$ $+ 14 \text{ mA})$ $= 22.5 \mu\text{A} + 0.1 \times (4.8 + 0.48 + 14) \text{ mA}$ $= 22.5 \mu\text{A} + 0.1 \times 19.28 \text{ mA}$ $= 22.5 \mu\text{A} + 1.928 \text{ mA}$ $= 1.95 \text{ mA}$
<p>This is the operating power with no WRITE or Flash memory Erase cycles in progress. Calculation is based on I_{OUT} = 0 mA.</p>	

MAXIMUM RATING

Stressing the device above the rating listed in the "Absolute Maximum Ratings" table may cause permanent damage to the device. These are stress ratings only and operation of the device at these or any other conditions above those indicated in the Operating sections of this specification is not im-

plied. Exposure to Absolute Maximum Rating conditions for extended periods may affect device reliability. Refer also to the STMicroelectronics SURE Program and other relevant quality documents.

Table 37. Absolute Maximum Ratings

Symbol	Parameter	Min.	Max.	Unit
T _{STG}	Storage Temperature	-65	125	°C
T _{LEAD}	Lead Temperature during Soldering (20 seconds max.) ¹		235	°C
V _{IO}	Input and Output Voltage (Q = V _{OH} or Hi-Z)	-0.6	7.0	V
V _{CC}	Supply Voltage	-0.6	7.0	V
V _{PP}	Device Programmer Supply Voltage	-0.6	14.0	V
V _{ESD}	Electrostatic Discharge Voltage (Human Body model) ²	-2000	2000	V

Note: 1. IPC/JEDEC J-STD-020A

2. JEDEC Std JESD22-A114A (C1=100pF, R1=1500 Ω, R2=500 Ω)

DC AND AC PARAMETERS

This section summarizes the operating and measurement conditions, and the DC and AC characteristics of the device. The parameters in the DC and AC Characteristic tables that follow are derived from tests performed under the Measure-

ment Conditions summarized in the relevant tables. Designers should check that the operating conditions in their circuit match the measurement conditions when relying on the quoted parameters.

Table 38. Operating Conditions

Symbol	Parameter	Min.	Max.	Unit
V_{CC}	Supply Voltage	3.0	3.6	V
T_A	Ambient Operating Temperature (industrial)	-40	85	°C
	Ambient Operating Temperature (commercial)	0	70	°C

Table 39. AC Measurement Conditions

Symbol	Parameter	Min.	Max.	Unit
C_L	Load Capacitance	30		pF

Note: 1. Output Hi-Z is defined as the point where data out is no longer driven.

Figure 32. AC Measurement I/O Waveform

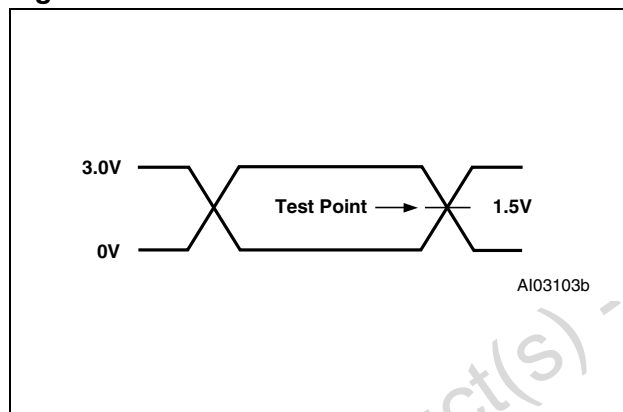

Figure 33. AC Measurement Load Circuit

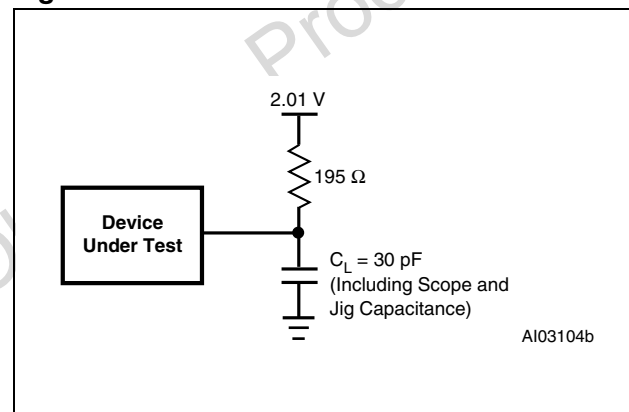

Table 40. Capacitance

Symbol	Parameter	Test Condition	Typ. ²	Max.	Unit
C_{IN}	Input Capacitance (for input pins)	$V_{IN} = 0V$	4	6	pF
C_{OUT}	Output Capacitance (for input/output pins)	$V_{OUT} = 0V$	8	12	pF
C_{VPP}	Capacitance (for CNTL2/ V_{PP})	$V_{PP} = 0V$	18	25	pF

Note: 1. Sampled only, not 100% tested.

2. Typical values are for $T_A = 25^\circ\text{C}$ and nominal supply voltages.

Table 41. AC Symbols for PLD Timing

Signal Letters	
A	Address Input
C	CEout Output
D	Input Data
E	E Input
G	Internal WDOG_ON signal
I	Interrupt Input
L	ALE Input
N	Reset Input or Output
P	Port Signal Output
Q	Output Data
R	\overline{WR} , \overline{UDS} , \overline{LDS} , \overline{DS} , IORD, \overline{PSEN} Inputs
S	Chip Select Input
T	R/ \overline{W} Input
W	Internal PDN Signal
M	Output Macrocell

Signal Behavior	
t	Time
L	Logic Level Low or ALE
H	Logic Level High
V	Valid
X	No Longer a Valid Logic Level
Z	Float
PW	Pulse Width

Example: t_{AVLX} – Time from Address Valid to ALE Invalid.

Figure 34. Switching Waveforms – Key

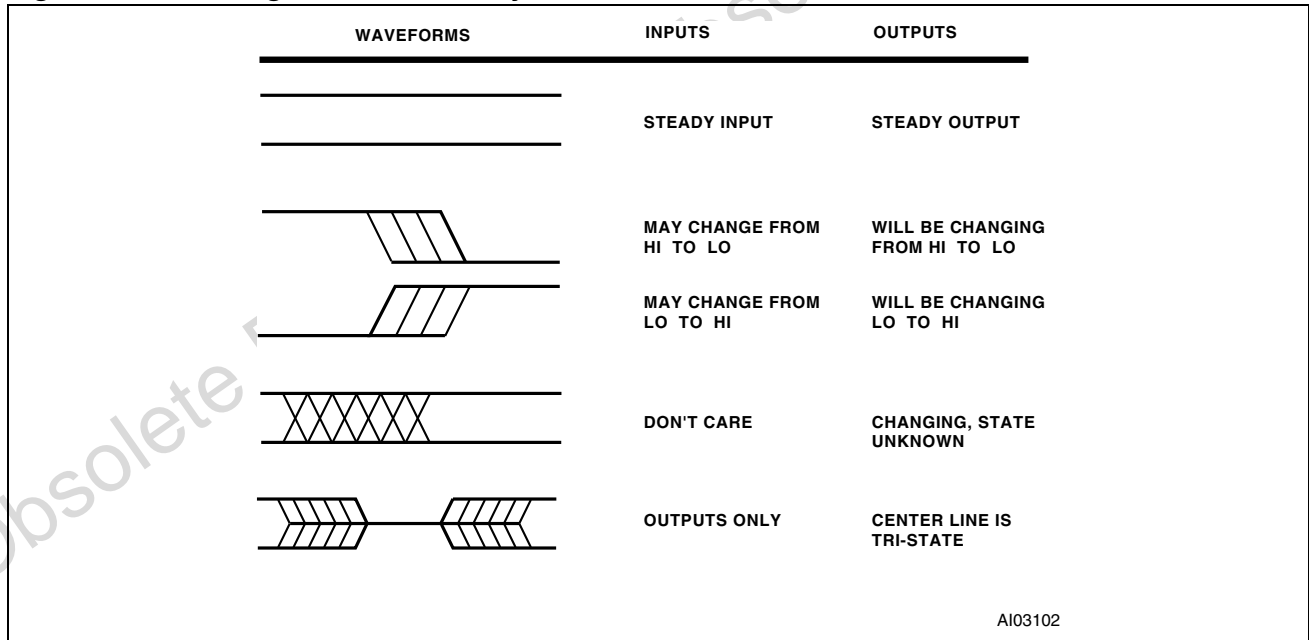

Table 42. DC Characteristics

Symbol	Parameter	Conditions	Min.	Typ.	Max.	Unit	
V _{IH}	High Level Input Voltage	3.0 V < V _{CC} < 3.6 V	0.7V _{CC}		V _{CC} +0.5	V	
V _{IL}	Low Level Input Voltage	3.0 V < V _{CC} < 3.6 V	-0.5		0.8	V	
V _{IH1}	Reset High Level Input Voltage	(Note 1)	0.8V _{CC}		V _{CC} +0.5	V	
V _{IL1}	Reset Low Level Input Voltage	(Note 1)	-0.5		0.2V _{CC} -0.1	V	
V _{HYS}	Reset Pin Hysteresis		0.3			V	
V _{LKO}	V _{CC} (min) for Flash Erase and Program		1.5		2.2	V	
V _{OL}	Output Low Voltage	I _{OL} = 20 μA, V _{CC} = 3.0 V		0.01	0.1	V	
		I _{OL} = 4 mA, V _{CC} = 3.0 V		0.15	0.45	V	
V _{OH}	Output High Voltage	I _{OH} = -20 μA, V _{CC} = 3.0 V	2.9	2.99		V	
		I _{OH} = -1 mA, V _{CC} = 3.0 V	2.7	2.8		V	
I _{SB}	Standby Supply Current for Power-down Mode	$\overline{CS1} > V_{CC} - 0.3 \text{ V}$ (Notes 2,3)		25	100	μA	
I _{LI}	Input Leakage Current	V _{SS} < V _{IN} < V _{CC}	-1	±0.1	1	μA	
I _{LO}	Output Leakage Current	0.45 < V _{IN} < V _{CC}	-10	±5	10	μA	
I _{CC} (DC) (Note 5)	Operating Supply Current	PLD Only	PLD_TURBO = Off, f = 0 MHz (Note 3)		0		μA/PT
			PLD_TURBO = On, f = 0 MHz		200	400	μA/PT
		Flash memory	During Flash memory WRITE/Erase Only		10	25	mA
			Read Only, f = 0 MHz		0	0	mA
SRAM	f = 0 MHz		0	0	mA		
I _{CC} (AC) (Note 5)	PLD AC Adder			note 4			
	Flash memory AC Adder			1.5	2.0	mA/ MHz	
	SRAM AC Adder			0.8	1.5	mA/ MHz	

Note: 1. Reset (Reset) has hysteresis. V_{IL1} is valid at or below 0.2V_{CC} -0.1. V_{IH1} is valid at or above 0.8V_{CC}.

2. CS1 deselected or internal PD is active.

3. PLD is in non-Turbo mode, and none of the inputs are switching.

4. Please see Figure 31 for the PLD current calculation.

5. I_{OUT} = 0 mA

Figure 35. Input to Output Disable / Enable

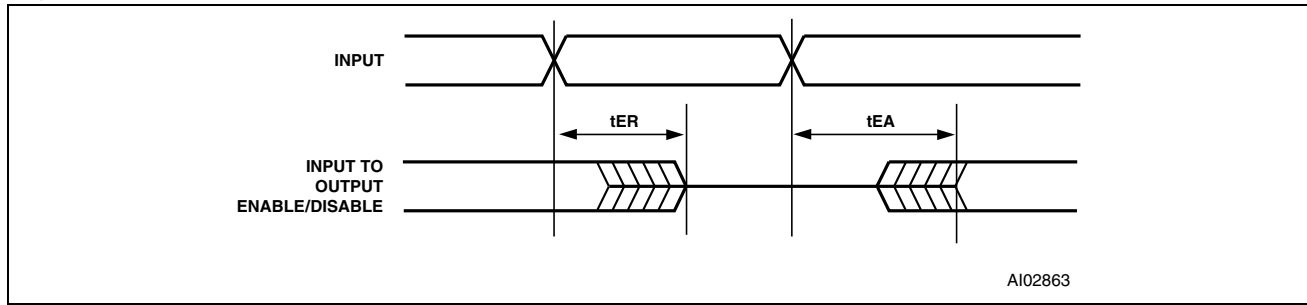

Table 43. CPLD Combinatorial Timing

Symbol	Parameter	Conditions	-10		-15		-20		PT Alloc	Turbo Off	Slew rate ¹	Unit
			Min	Max	Min	Max	Min	Max				
t _{PD}	CPLD Input Pin/ Feedback to CPLD Combinatorial Output			40		45		50	+ 4	+ 20	- 6	ns
t _{EA}	CPLD Input to CPLD Output Enable			43		45		50		+ 20	- 6	ns
t _{ER}	CPLD Input to CPLD Output Disable			43		45		50		+ 20	- 6	ns
t _{ARP}	CPLD Register Clear or Preset Delay			40		43		48		+ 20	- 6	ns
t _{ARPW}	CPLD Register Clear or Preset Pulse Width		25		30		35			+ 20		ns
t _{ARD}	CPLD Array Delay	Any macrocell		25		29		33	+ 4			ns

Note: 1. Fast Slew Rate output available on PA3-PA0, PB3-PB0, and PD2-PD0. Decrement times by given amount.

Figure 36. Synchronous Clock Mode Timing – PLD

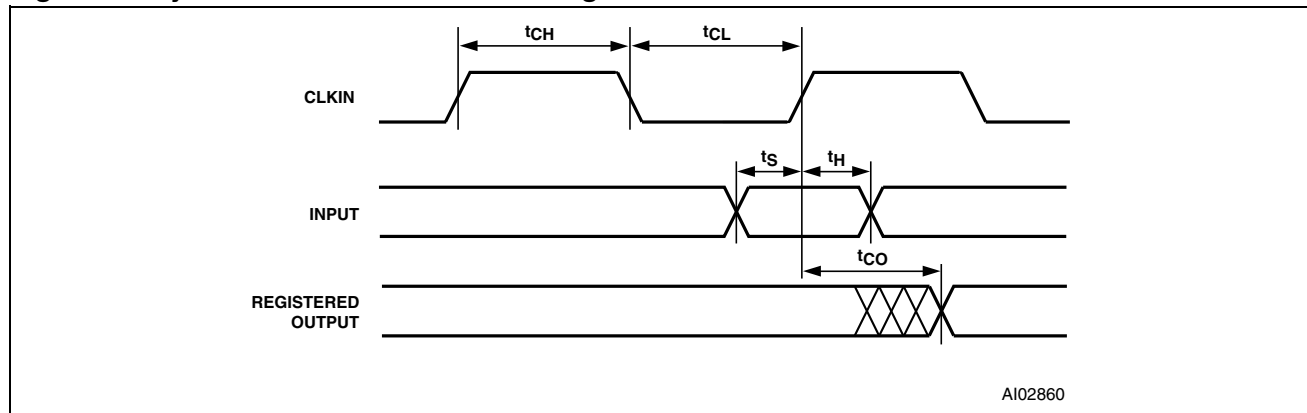

Table 44. CPLD Macrocell Synchronous Clock Mode Timing

Symbol	Parameter	Conditions	-10		-15		-20		PT Alloc	Turbo Off	Slew rate ¹	Unit
			Min	Max	Min	Max	Min	Max				
f _{MAX}	Maximum Frequency External Feedback	1/(t _s +t _{CO})		22.2		18.8		15.8				MHz
	Maximum Frequency Internal Feedback (f _{CNT})	1/(t _s +t _{CO} -10)		28.5		23.2		18.8				MHz
	Maximum Frequency Pipelined Data	1/(t _{CH} +t _{CL})		40.0		33.3		31.2				MHz
t _s	Input Setup Time		20		25		30		+ 4	+ 20		ns
t _H	Input Hold Time		0		0		0					ns
t _{CH}	Clock High Time	Clock Input	15		15		16					ns
t _{CL}	Clock Low Time	Clock Input	10		15		16					ns
t _{CO}	Clock to Output Delay	Clock Input		25		28		33			- 6	ns
t _{ARD}	CPLD Array Delay	Any macrocell		25		29		33	+ 4			ns
t _{MIN}	Minimum Clock Period ²	t _{CH} +t _{CL}	25		29		32					ns

Note: 1. Fast Slew Rate output available on PA3-PA0, PB3-PB0, and PD2-PD0. Decrement times by given amount.

2. CLKIN (PD1) t_{CLCL} = t_{CH} + t_{CL}.

Figure 37. Asynchronous Reset / Preset

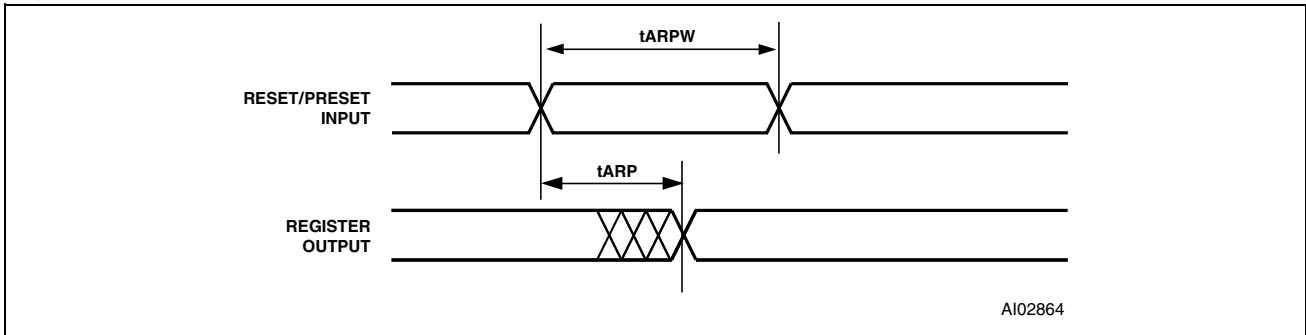

Figure 38. Asynchronous Clock Mode Timing (product term clock)

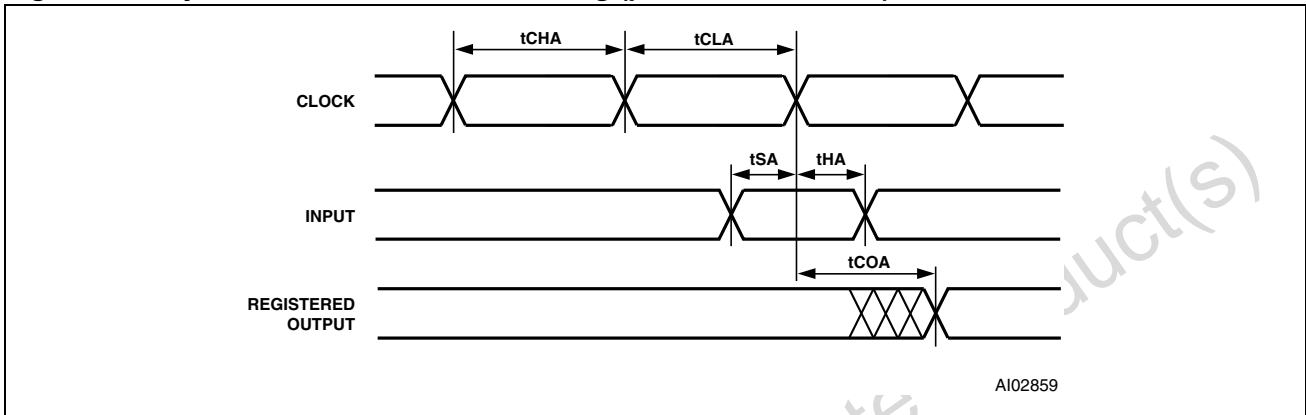

Table 45. CPLD Macrocell Asynchronous Clock Mode Timing

Symbol	Parameter	Conditions	-10		-15		-20		PT Alloc	Turbo Off	Slew Rate	Unit
			Min	Max	Min	Max	Min	Max				
f _{MAXA}	Maximum Frequency External Feedback	1/(t _{SA} +t _{COA})		21.7		19.2		16.9				MHz
	Maximum Frequency Internal Feedback (f _{CNTA})	1/(t _{SA} +t _{COA} -10)		27.8		23.8		20.4				MHz
	Maximum Frequency Pipelined Data	1/(t _{CHA} +t _{CLA})		33.3		27		24.4				MHz
t _{SA}	Input Setup Time		10		12		13		+ 4	+ 20		ns
t _{HA}	Input Hold Time		12		15		17					ns
t _{CHA}	Clock High Time		17		22		25			+ 20		ns
t _{CLA}	Clock Low Time		13		15		16			+ 20		ns
t _{COA}	Clock to Output Delay			36		40		46		+ 20	- 6	ns
t _{ARD}	CPLD Array Delay	Any macrocell		25		29		33	+ 4			ns
t _{MINA}	Minimum Clock Period	1/f _{CNTA}	36		42		49					ns

Figure 39. Input Macrocell Timing (product term clock)

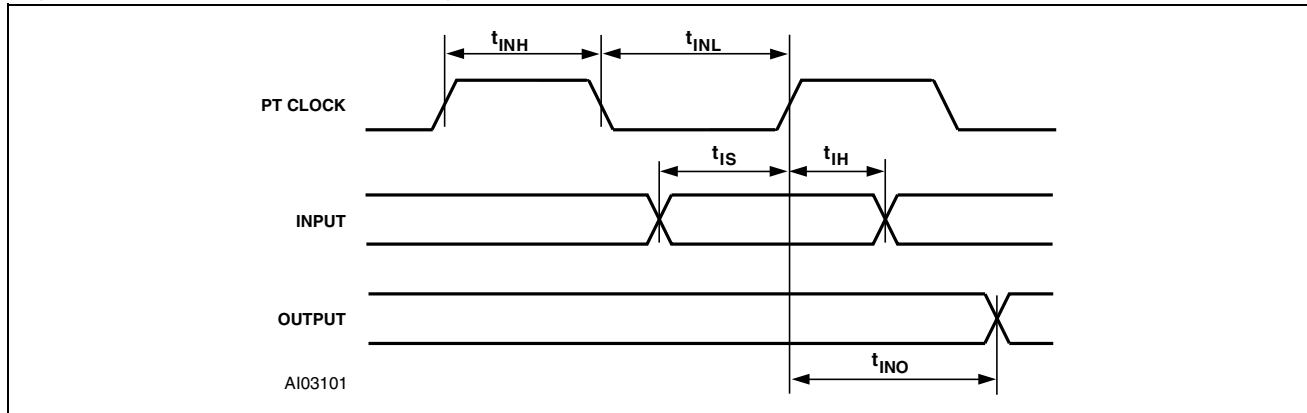
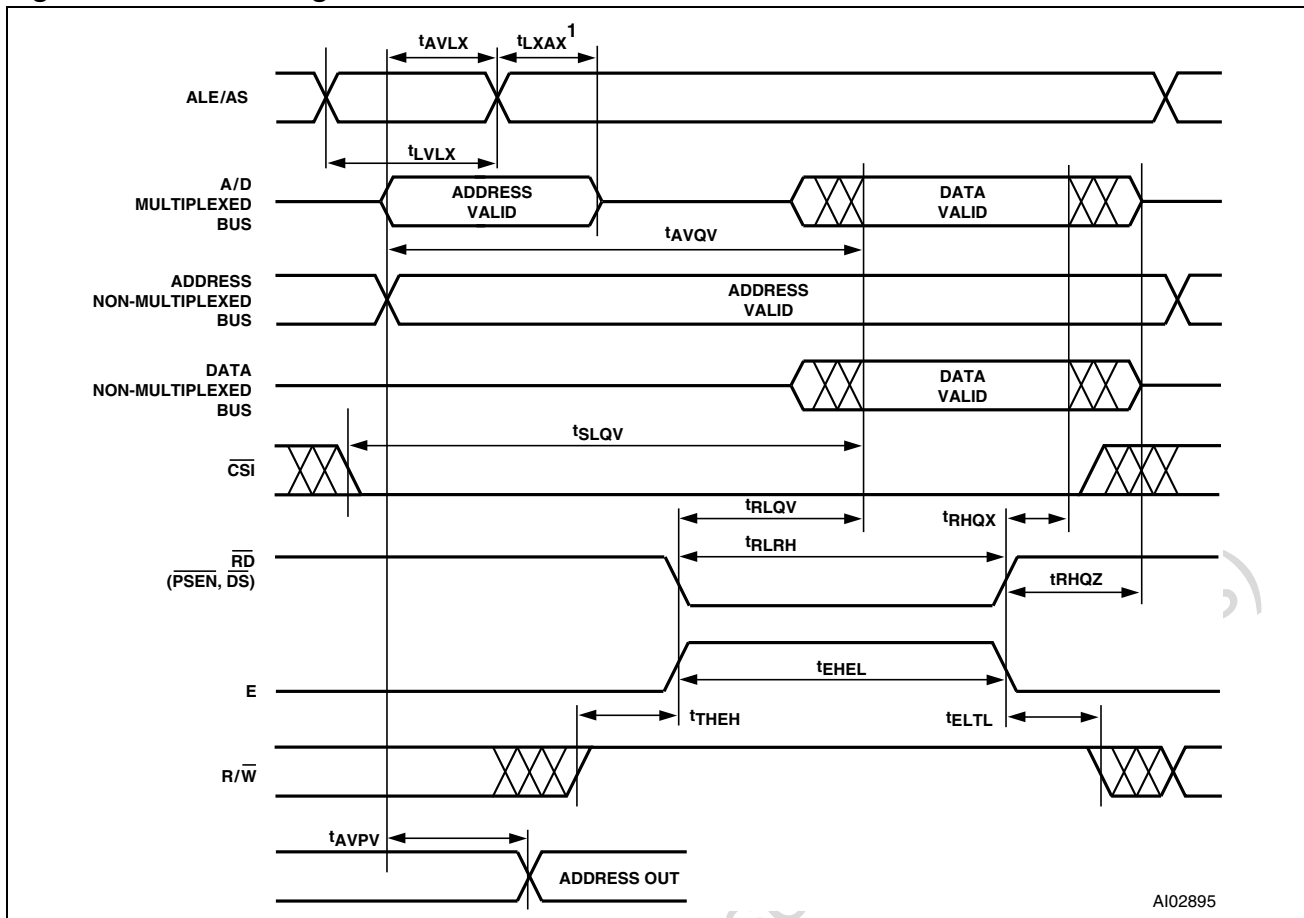

Table 46. Input Macrocell Timing

Symbol	Parameter	Conditions	-10		-15		-20		PT Alloc	Turbo Off	Unit
			Min	Max	Min	Max	Min	Max			
t_{IS}	Input Setup Time	(Note 1)	0		0		0				ns
t_{IH}	Input Hold Time	(Note 1)	25		25		30			+ 20	ns
t_{INH}	NIB Input High Time	(Note 1)	12		13		15				ns
t_{INL}	NIB Input Low Time	(Note 1)	12		13		15				ns
t_{INO}	NIB Input to Combinatorial Delay	(Note 1)		46		62		70	+ 4	+ 20	ns

Note: 1. Inputs from Port A, B, and C relative to register/latch clock from the PLD. ALE latch timings refer to t_{AVLX} and t_{LXAX} .

Figure 40. READ Timing



Note: 1. t_{AVLX} and t_{LXAX} are not required for 80C251 in Page Mode or 80C51XA in Burst Mode.

Table 47. READ Timing

Symbol	Parameter	Conditions	-10		-15		-20		Turbo Off	Unit
			Min	Max	Min	Max	Min	Max		
t _{LVLX}	ALE or AS Pulse Width		26		26		30			ns
t _{AVLX}	Address Setup Time	(Note ³)	9		10		12			ns
t _{LXAX}	Address Hold Time	(Note ³)	9		12		14			ns
t _{AVQV}	Address Valid to Data Valid	(Note ³)		100		150		200	+ 20	ns
t _{SLQV}	CS Valid to Data Valid			100		150		200		ns
t _{RLQV}	\overline{RD} to Data Valid 8-bit Bus	(Note ⁵)		35		35		40		ns
	\overline{RD} or \overline{PSEN} to Data Valid 8-bit Bus, 8031, 80251	(Note ²)		45		50		55		ns
t _{RHQX}	\overline{RD} Data Hold Time	(Note ¹)	0		0		0			ns
t _{RLRH}	\overline{RD} Pulse Width		38		40		45			ns
t _{RHQZ}	\overline{RD} to Data High-Z	(Note ¹)		38		40		45		ns
t _{EH}	E Pulse Width		40		45		52			ns
t _{THEH}	R/ \overline{W} Setup Time to Enable		15		18		20			ns
t _{ELTL}	R/ \overline{W} Hold Time After Enable		0		0		0			ns
t _{AVPV}	Address Input Valid to Address Output Delay	(Note ⁴)		33		35		40		ns

- Note: 1. \overline{RD} timing has the same timing as \overline{DS} , \overline{LDS} , \overline{UDS} , and \overline{PSEN} signals.
2. \overline{RD} and \overline{PSEN} have the same timing for 8031.
3. Any input used to select an internal PSD function.
4. In multiplexed mode latched address generated from ADIO delay to address output on any Port.
5. \overline{RD} timing has the same timing as \overline{DS} , \overline{LDS} , and \overline{UDS} signals.

Figure 41. WRITE Timing

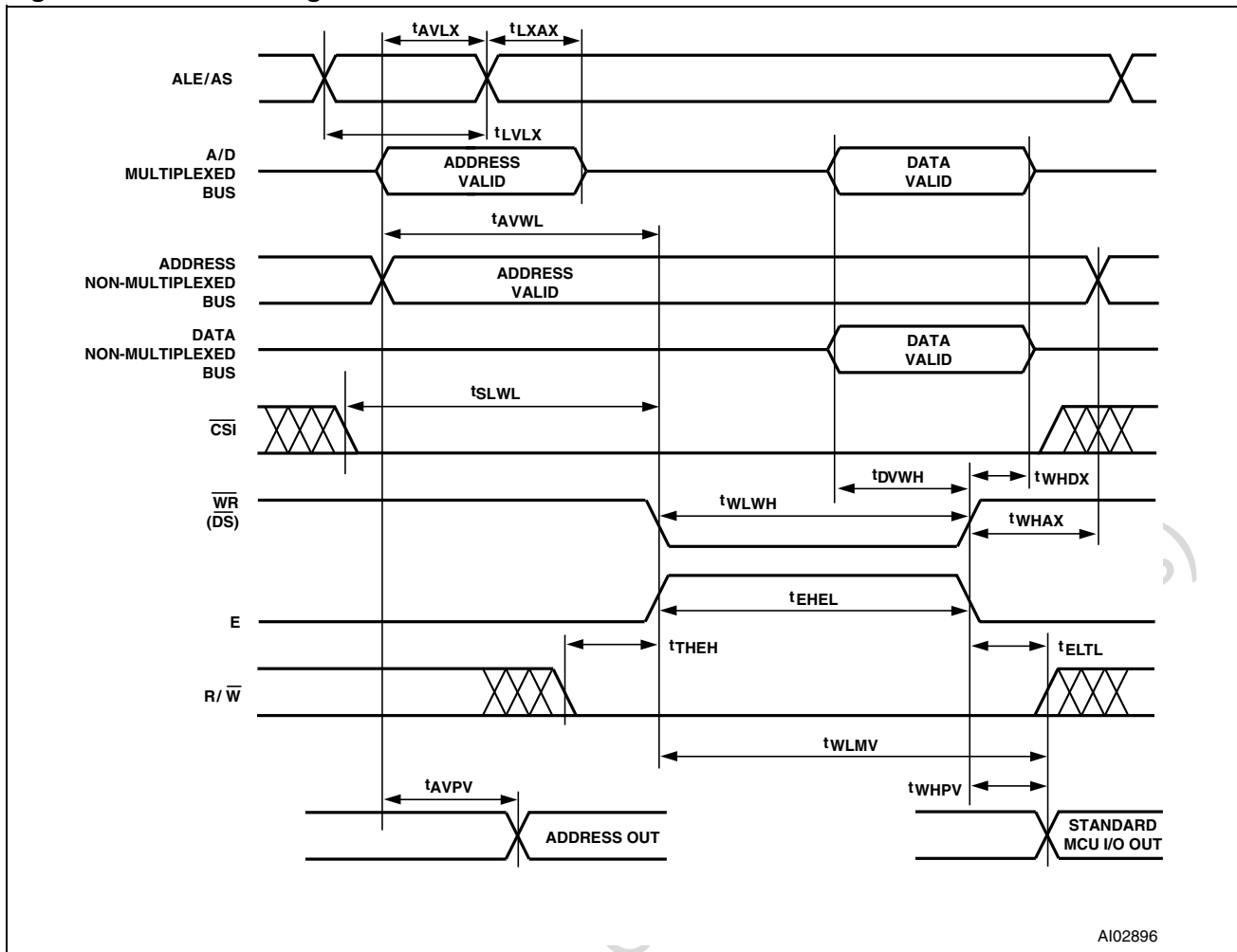

Table 48. WRITE Timing

Symbol	Parameter	Conditions	-10		-15		-20		Unit
			Min	Max	Min	Max	Min	Max	
t _{LVLX}	ALE or AS Pulse Width		26		26		30		
t _{AVLX}	Address Setup Time	(Note ¹)	9		10		12		ns
t _{LXAX}	Address Hold Time	(Note ¹)	9		12		14		ns
t _{AVWL}	Address Valid to Leading Edge of \overline{WR}	(Notes ^{1,3})	17		20		25		ns
t _{SLWL}	\overline{CS} Valid to Leading Edge of \overline{WR}	(Note ³)	17		20		25		ns
t _{DVWH}	\overline{WR} Data Setup Time	(Note ³)	45		45		50		ns
t _{WHDX}	\overline{WR} Data Hold Time	(Note ³)	7		8		10		ns
t _{WLWH}	\overline{WR} Pulse Width	(Note ³)	46		48		53		ns
t _{WHAX1}	Trailing Edge of \overline{WR} to Address Invalid	(Note ³)	10		12		17		ns
t _{WHAX2}	Trailing Edge of \overline{WR} to DPLD Address Invalid	(Note ^{3,6})	0		0		0		ns
t _{WHPV}	Trailing Edge of \overline{WR} to Port Output Valid Using I/O Port Data Register	(Note ³)		33		35		40	ns
t _{DVMV}	Data Valid to Port Output Valid Using Macrocell Register Preset/Clear	(Notes ^{3,5})		70		70		80	ns
t _{AVPV}	Address Input Valid to Address Output Delay	(Note ²)		33		35		40	ns
t _{WLMV}	\overline{WR} Valid to Port Output Valid Using Macrocell Register Preset/Clear	(Notes ^{3,4})		70		70		80	ns

Note: 1. Any input used to select an internal PSD function.

2. In multiplexed mode, latched address generated from ADIO delay to address output on any port.

3. \overline{WR} has the same timing as E, \overline{LDS} , \overline{UDS} , \overline{WRL} , and \overline{WRH} signals.

4. Assuming data is stable before active WRITE signal.

5. Assuming WRITE is active before data becomes valid.

6. TWHAX2 is the address hold time for DPLD inputs that are used to generate Sector Select signals for internal PSD memory.

Table 49. Program, WRITE and Erase Times

Symbol	Parameter	Min.	Typ.	Max.	Unit
	Flash Program		8.5		s
	Flash Bulk Erase ¹ (pre-programmed)		3	30	s
	Flash Bulk Erase (not pre-programmed)		5		s
t _{WHQV3}	Sector Erase (pre-programmed)		1	30	s
t _{WHQV2}	Sector Erase (not pre-programmed)		2.2		s
t _{WHQV1}	Byte Program		14	1200	μs
	Program / Erase Cycles (per Sector)	100,000			cycles
t _{WHWLO}	Sector Erase Time-Out		100		μs
t _{Q7VQV}	DQ7 Valid to Output (DQ7-DQ0) Valid (Data Polling) ²			30	ns

Note: 1. Programmed to all zero before erase.

2. The polling status, DQ7, is valid t_{Q7VQV} time units before the data byte, DQ0-DQ7, is valid for reading.

Figure 42. Peripheral I/O READ Timing

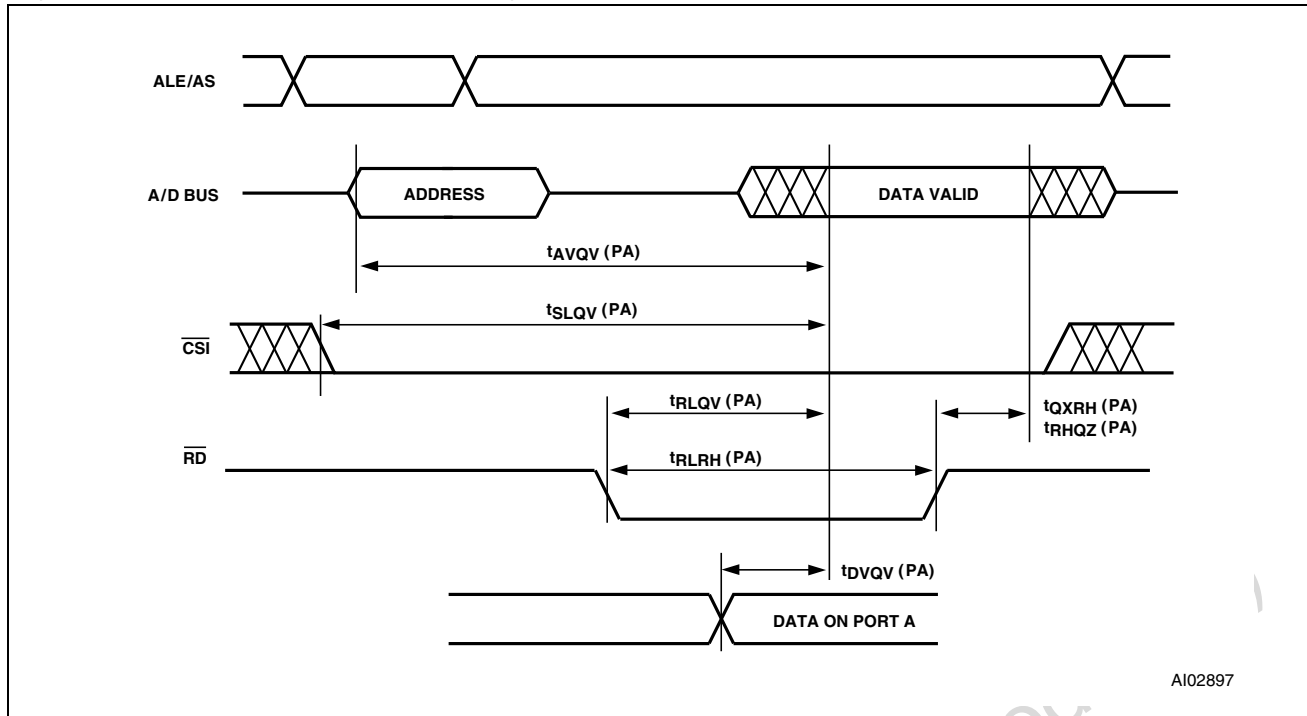

AI02897

Table 50. Port A Peripheral Data Mode READ Timing

Symbol	Parameter	Conditions	-10		-15		-20		Turbo Off	Unit
			Min	Max	Min	Max	Min	Max		
tAVQV-PA	Address Valid to Data Valid	(Note 3)		50		50		50	+ 20	ns
tSLQV-PA	CS Valid to Data Valid			37		45		50	+ 20	ns
tRLQV-PA	RD to Data Valid	(Notes 1,4)		37		40		45		ns
	RD to Data Valid 8031 Mode			45		45		50		ns
tDVQV-PA	Data In to Data Out Valid			38		40		45		ns
tQXRH-PA	RD Data Hold Time		0		0		0			ns
tRLRH-PA	RD Pulse Width	(Note 1)	36		36		46			ns
tRHQZ-PA	RD to Data High-Z	(Note 1)		36		40		45		ns

Figure 43. Peripheral I/O WRITE Timing

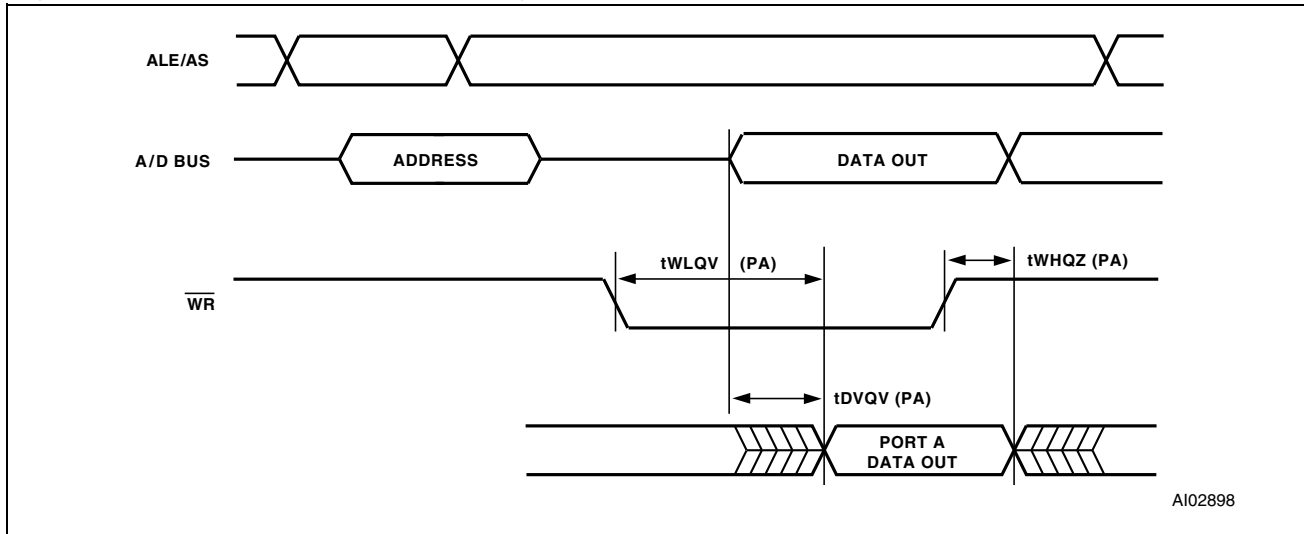

Table 51. Port A Peripheral Data Mode WRITE Timing

Symbol	Parameter	Conditions	-10		-15		-20		Unit
			Min	Max	Min	Max	Min	Max	
$t_{WLQV-PA}$	\overline{WR} to Data Propagation Delay	(Note ²)		42	45		55	ns	
$t_{DVQV-PA}$	Data to Port A Data Propagation Delay	(Note ⁵)		38	40		45	ns	
$t_{WHQZ-PA}$	\overline{WR} Invalid to Port A Tri-state	(Note ²)		33	33		35	ns	

- Note: 1. \overline{RD} has the same timing as \overline{DS} , \overline{LDS} , \overline{UDS} , and \overline{PSEN} (in 8031 combined mode).
 2. \overline{WR} has the same timing as the \overline{E} , \overline{LDS} , \overline{UDS} , \overline{WRL} , and \overline{WRH} signals.
 3. Any input used to select Port A Data Peripheral mode.
 4. Data is already stable on Port A.
 5. Data stable on ADIO pins to data on Port A.

Figure 44. Reset ($\overline{\text{RESET}}$) Timing

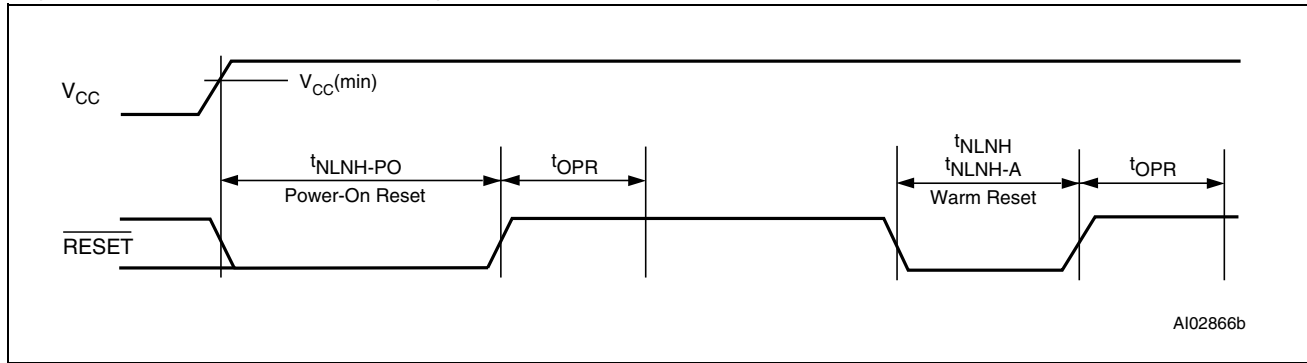

Table 52. Reset ($\overline{\text{Reset}}$) Timing

Symbol	Parameter	Conditions	Min	Max	Unit
t_{NINH}	RESET Active Low Time ¹		300		ns
$t_{\text{NINH-PO}}$	Power On Reset Active Low Time		1		ms
$t_{\text{NINH-A}}$	Warm Reset ²		25		μs
t_{OPR}	RESET High to Operational Device			300	ns

Note: 1. Reset ($\overline{\text{RESET}}$) does not reset Flash memory Program or Erase cycles.

2. Warm reset aborts Flash memory Program or Erase cycles, and puts the device in READ Mode.

Table 53. Power-down Timing

Symbol	Parameter	Conditions	-10		-15		-20		Unit
			Min	Max	Min	Max	Min	Max	
t_{LVDV}	ALE Access Time from Power-down			145		150		200	ns
t_{CLWH}	Maximum Delay from APD Enable to Internal PDN Valid Signal	Using CLKIN (PD1)	$15 * t_{\text{CLCL}}^1$						μs

Note: 1. t_{CLCL} is the period of CLKIN (PD1).

Figure 45. ISC Timing

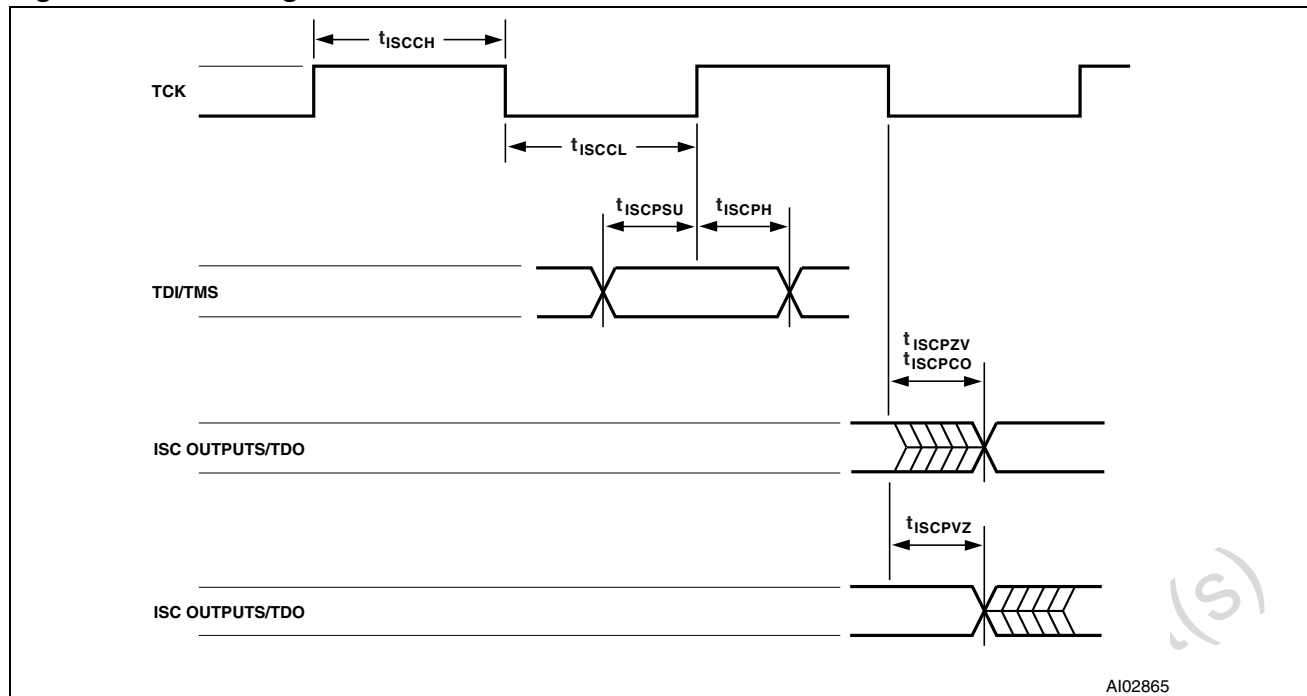

Table 54. ISC Timing

Symbol	Parameter	Conditions	-10		-15		-20		Unit
			Min	Max	Min	Max	Min	Max	
t_{ISCCF}	Clock (TCK, PC1) Frequency (except for PLD)	(Note ¹)		12		10		9	MHz
t_{ISCCH}	Clock (TCK, PC1) High Time (except for PLD)	(Note ¹)	40		45		51		ns
t_{ISCCL}	Clock (TCK, PC1) Low Time (except for PLD)	(Note ¹)	40		45		51		ns
t_{ISCCFP}	Clock (TCK, PC1) Frequency (PLD only)	(Note ²)		2		2		2	MHz
t_{ISCCHP}	Clock (TCK, PC1) High Time (PLD only)	(Note ²)	240		240		240		ns
t_{ISCCLP}	Clock (TCK, PC1) Low Time (PLD only)	(Note ²)	240		240		240		ns
t_{ISCPSU}	ISC Port Set Up Time		12		13		15		ns
t_{ISCPH}	ISC Port Hold Up Time		5		5		5		ns
t_{ISPCO}	ISC Port Clock to Output			30		36		40	ns
t_{ISCPZV}	ISC Port High-Impedance to Valid Output			30		36		40	ns
t_{ISCPVZ}	ISC Port Valid Output to High-Impedance			30		36		40	ns

Note: 1. For non-PLD Programming, Erase or in ISC by-pass mode.

2. For Program or Erase PLD only.

PACKAGE MECHANICAL

In order to meet environmental requirements, ST offers these devices in different grades of ECO-PACK® packages, depending on their level of environmental compliance.

ECOPACK® specifications, grade definitions and product status are available at: www.st.com. ECO-PACK® is an ST trademark.

Figure 46. PQFP52 Connections

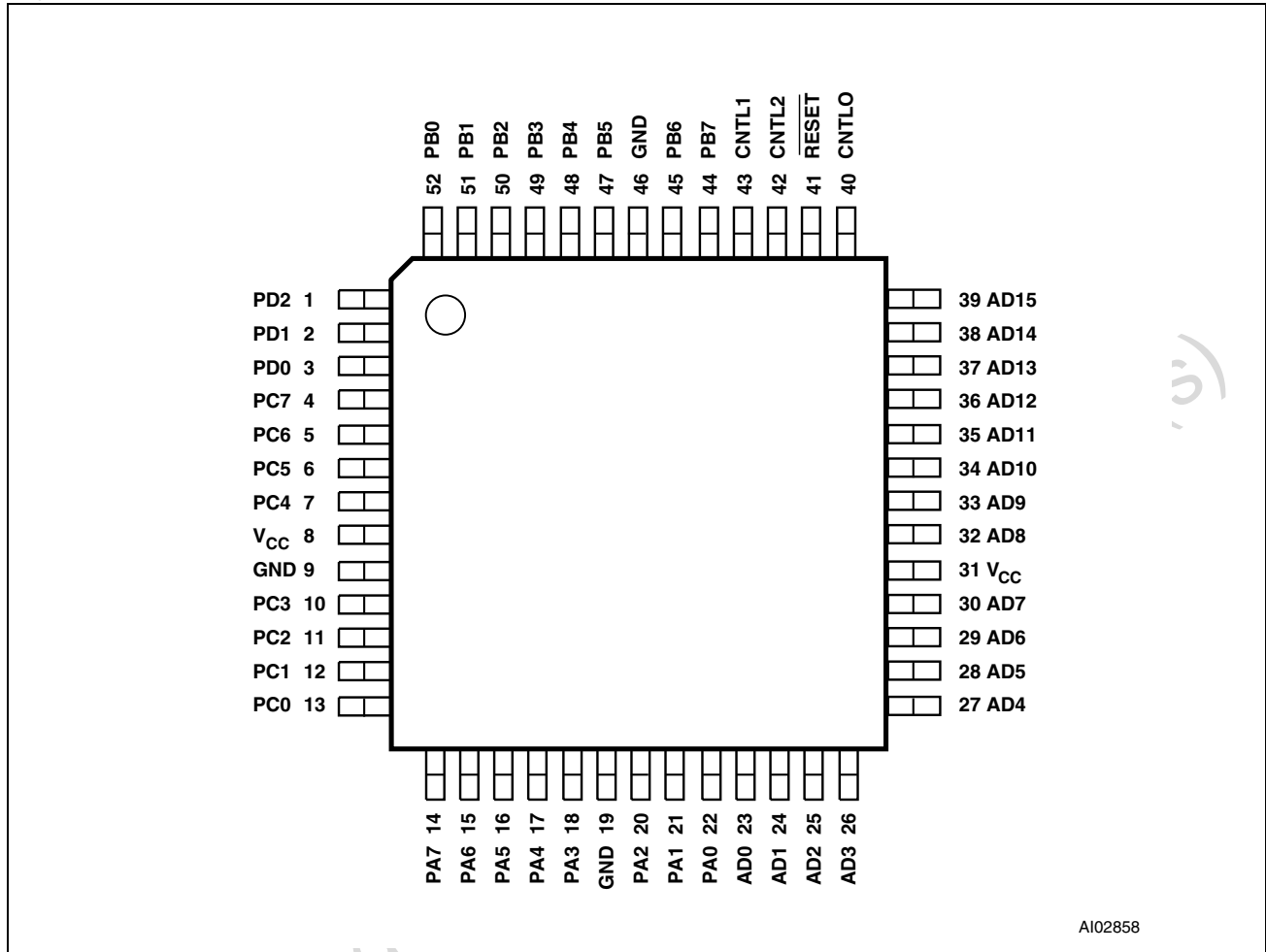

Obsolete Product

Figure 47. PLCC52 Connections

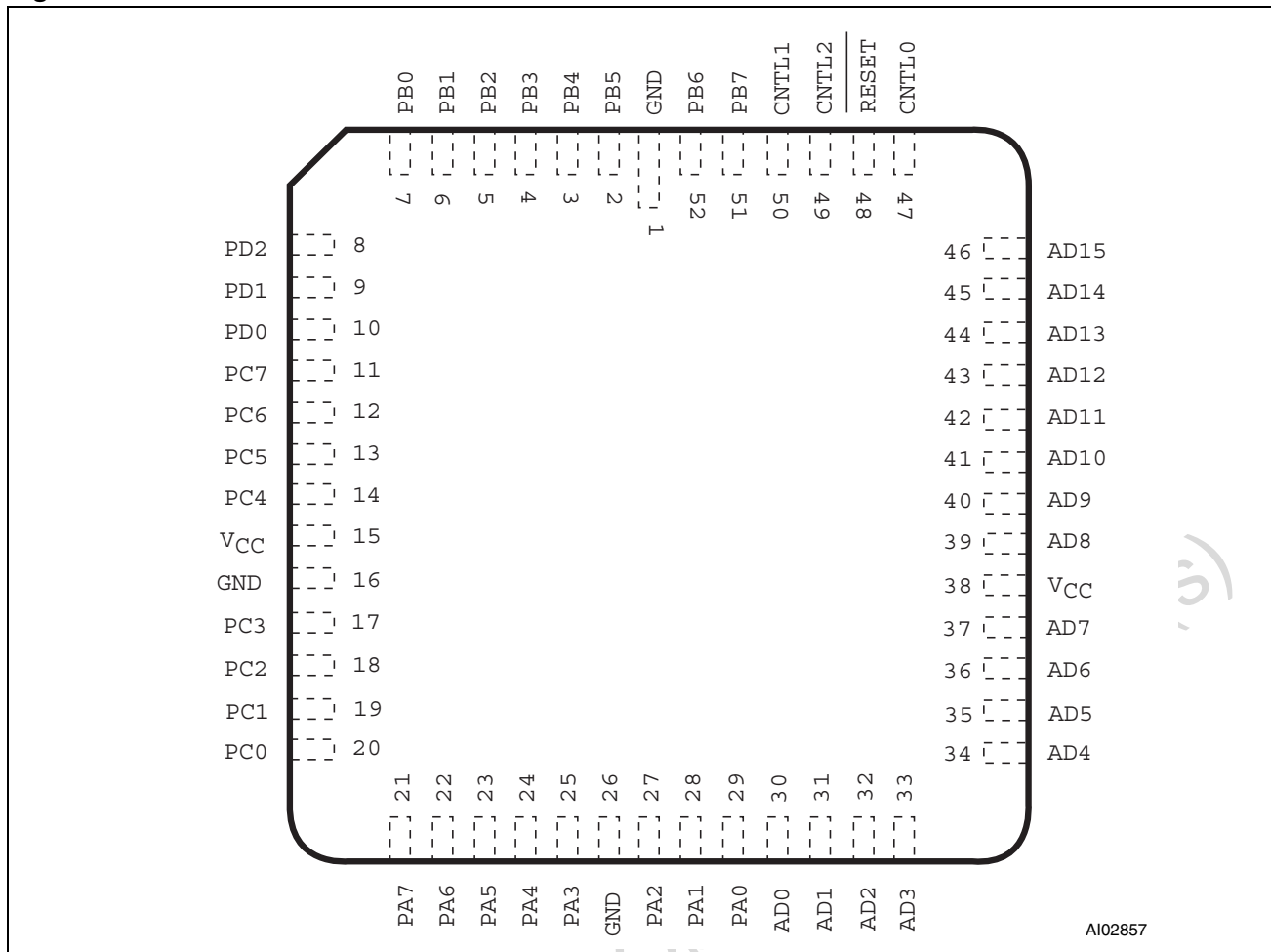
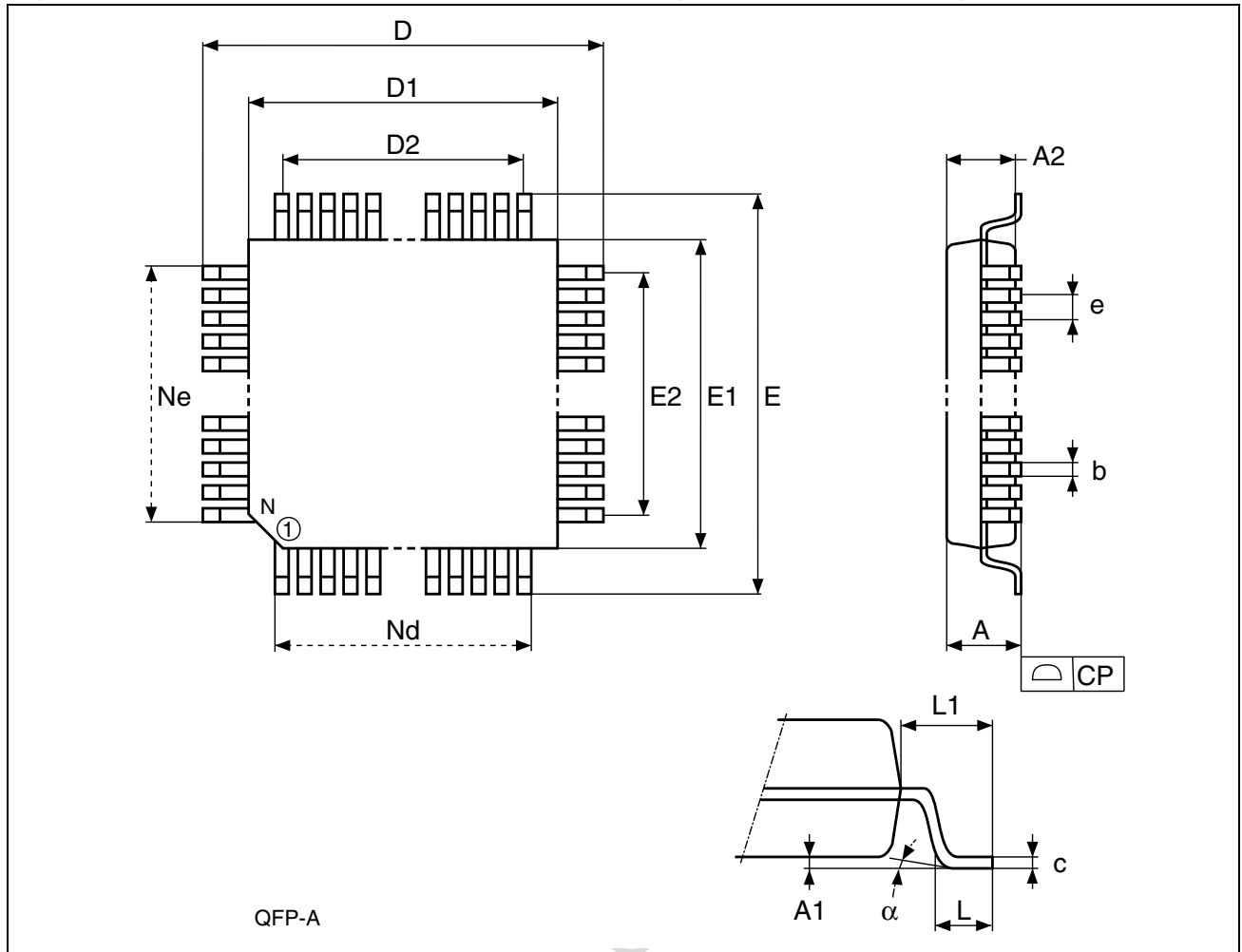

Figure 48. PQFP52 - 52-pin Plastic, Quad, Flat Package Mechanical Drawing



Note: Drawing is not to scale.

Obsolete Product(s)

Table 55. PQFP52 - 52-pin Plastic, Quad, Flat Package Mechanical Dimensions

Symb.	mm			inches		
	Typ.	Min.	Max.	Typ.	Min.	Max.
A			2.35			0.093
A1			0.25			0.010
A2	2.00	1.80	2.10	0.079	0.077	0.083
b		0.22	0.38		0.009	0.015
c		0.11	0.23		0.004	0.009
D	13.20	13.15	13.25	0.520	0.518	0.522
D1	10.00	9.95	10.05	0.394	0.392	0.396
D2	7.80	–	–	0.307	–	–
E	13.20	13.15	13.25	0.520	0.518	0.522
E1	10.00	9.95	10.05	0.394	0.392	0.396
E2	7.80	–	–	0.307	–	–
e	0.65	–	–	0.026		
L	0.88	0.73	1.03	0.035	0.029	0.041
L1	1.60	–	–	0.063		
α		0°	7°		0°	7°
N	52			52		
Nd	13			13		
Ne	13			13		
CP			0.10			0.004

Figure 49. PLCC52 - 52-lead Plastic Lead, Chip Carrier Package Mechanical Drawing

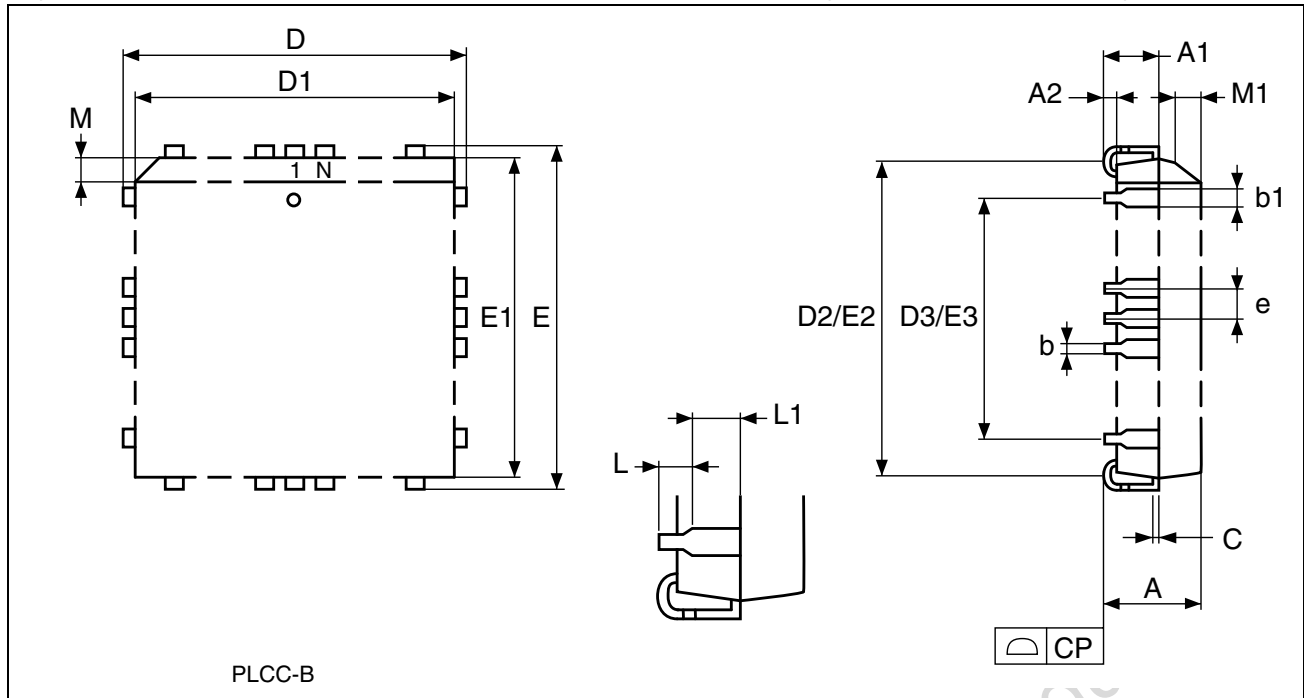

Note: Drawing is not to scale.

Table 56. PLCC52 - 52-lead Plastic Lead, Chip Carrier Package Mechanical Dimensions

Symbol	mm			inches		
	Typ.	Min.	Max.	Typ.	Min.	Max.
A		4.19	4.57		0.165	0.180
A1		2.54	2.79		0.100	0.110
A2		-	0.91		-	0.036
B		0.33	0.53		0.013	0.021
B1		0.66	0.81		0.026	0.032
C		0.246	0.261		0.0097	0.0103
D		19.94	20.19		0.785	0.795
D1		19.05	19.15		0.750	0.754
D2		17.53	18.54		0.690	0.730
E		19.94	20.19		0.785	0.795
E1		19.05	19.15		0.750	0.754
E2		17.53	18.54		0.690	0.730
e	1.27	-	-	0.050	-	-
R	0.89	-	-	0.035	-	-
N		52			52	
Nd		13			13	
Ne		13			13	

PART NUMBERING

Table 57. Ordering Information Scheme

Example:	PSD8	3	4	F	2	V	-	10	J	I	T
Device Type											
PSD8 = 8-bit PSD with register logic											
PSD9 = 8-bit PSD with combinatorial logic											
SRAM Capacity											
3 = 64 Kbit											
Flash Memory Capacity											
4 = 2 Mbit (256K x 8)											
2nd Flash Memory											
2 = 256 Kbit (32K x 8) Flash memory											
Operating Voltage											
blank = $V_{CC} = 4.5$ to $5.5V^{(1)}$											
V = $V_{CC} = 3.0$ to $3.6V$											
Speed											
10 = 100ns											
15 = 150ns											
20 = 200ns											
Package											
J = ECOPACK PLCC52											
M = ECOPACK PQFP52											
Temperature Range											
blank = 0 to 70 °C (Commercial)											
I = -40 to 85 °C (Industrial)											
Option											
T = Tape & Reel Packing											

Note: 1. The $5V \pm 10\%$ devices are not covered by this data sheet, but by the PSD834F2 data sheet.

For a list of available options (e.g., speed, package) or for further information on any aspect of this device, please contact your nearest ST Sales Office.

APPENDIX A. PQFQ52 PIN ASSIGNMENTS

Table 58. PQFP52 Connections (Figure 46)

Pin Number	Pin Assignments
1	PD2
2	PD1
3	PD0
4	PC7
5	PC6
6	PC5
7	PC4
8	V _{CC}
9	GND
10	PC3
11	PC2
12	PC1
13	PC0
14	PA7
15	PA6
16	PA5
17	PA4
18	PA3
19	GND
20	PA2
21	PA1
22	PA0
23	AD0
24	AD1
25	AD2
26	AD3

Pin Number	Pin Assignments
27	AD4
28	AD5
29	AD6
30	AD7
31	V _{CC}
32	AD8
33	AD9
34	AD10
35	AD11
36	AD12
37	AD13
38	AD14
39	AD15
40	CNTL0
41	RESET
42	CNTL2
43	CNTL1
44	PB7
45	PB6
46	GND
47	PB5
48	PB4
49	PB3
50	PB2
51	PB1
52	PB0

APPENDIX B. PLCC52 PIN ASSIGNMENTS

Table 59. PLCC52 Connections

Pin Number	Pin Assignments
1	GND
2	PB5
3	PB4
4	PB3
5	PB2
6	PB1
7	PB0
8	PD2
9	PD1
10	PD0
11	PC7
12	PC6
13	PC5
14	PC4
15	V _{CC}
16	GND
17	PC3
18	PC2
19	PC1
20	PC0
21	PA7
22	PA6
23	PA5
24	PA4
25	PA3
26	GND

Pin Number	Pin Assignments
27	PA2
28	PA1
29	PA0
30	AD0
31	AD1
32	AD2
33	AD3
34	AD4
35	AD5
36	AD6
37	AD7
38	V _{CC}
39	AD8
40	AD9
41	AD10
42	AD11
43	AD12
44	AD13
45	AD14
46	AD15
47	CNTL0
48	RESET
49	CNTL2
50	CNTL1
51	PB7
52	PB6

REVISION HISTORY

Table 60. Document Revision History

Date	Version	Description of Revision
15-Feb-2002	1.0	Document written
18-Nov-03	2.0	Reformatted; correct package references (Figure 1)
09-Jan-2009	3.0	<p>Updated datasheet status to “not for new design”.</p> <p>Backup battery feature removed: updated FEATURES SUMMARY, Table 4 (pins PC2 and PC4 configurations), KEY FEATURES, Memory section, SRAM section, Port C – Functionality and Structure section. Removed SRAM standby mode in POWER MANAGEMENT. Updated PC2 in Table 59. PLCC52 Connections. Removed V_{STBY}, I_{STBY}, V_{STBYON}, V_{OH1}, V_{DF} and I_{IDLE} from Table 42.DC Characteristics. Removed V_{STBYON} timings table.</p> <p>Added ECOPACK text in cover page and PACKAGE MECHANICAL, page 86</p> <p>Updated disclaimer text.</p>

Obsolete Product(s) - Obsolete Product(s)

Please Read Carefully:

Information in this document is provided solely in connection with ST products. STMicroelectronics NV and its subsidiaries ("ST") reserve the right to make changes, corrections, modifications or improvements, to this document, and the products and services described herein at any time, without notice.

All ST products are sold pursuant to ST's terms and conditions of sale.

Purchasers are solely responsible for the choice, selection and use of the ST products and services described herein, and ST assumes no liability whatsoever relating to the choice, selection or use of the ST products and services described herein.

No license, express or implied, by estoppel or otherwise, to any intellectual property rights is granted under this document. If any part of this document refers to any third party products or services it shall not be deemed a license grant by ST for the use of such third party products or services, or any intellectual property contained therein or considered as a warranty covering the use in any manner whatsoever of such third party products or services or any intellectual property contained therein.

UNLESS OTHERWISE SET FORTH IN ST'S TERMS AND CONDITIONS OF SALE ST DISCLAIMS ANY EXPRESS OR IMPLIED WARRANTY WITH RESPECT TO THE USE AND/OR SALE OF ST PRODUCTS INCLUDING WITHOUT LIMITATION IMPLIED WARRANTIES OF MERCHANTABILITY, FITNESS FOR A PARTICULAR PURPOSE (AND THEIR EQUIVALENTS UNDER THE LAWS OF ANY JURISDICTION), OR INFRINGEMENT OF ANY PATENT, COPYRIGHT OR OTHER INTELLECTUAL PROPERTY RIGHT.

UNLESS EXPRESSLY APPROVED IN WRITING BY AN AUTHORIZED ST REPRESENTATIVE, ST PRODUCTS ARE NOT RECOMMENDED, AUTHORIZED OR WARRANTED FOR USE IN MILITARY, AIR CRAFT, SPACE, LIFE SAVING, OR LIFE SUSTAINING APPLICATIONS, NOR IN PRODUCTS OR SYSTEMS WHERE FAILURE OR MALFUNCTION MAY RESULT IN PERSONAL INJURY, DEATH, OR SEVERE PROPERTY OR ENVIRONMENTAL DAMAGE. ST PRODUCTS WHICH ARE NOT SPECIFIED AS "AUTOMOTIVE GRADE" MAY ONLY BE USED IN AUTOMOTIVE APPLICATIONS AT USER'S OWN RISK.

Resale of ST products with provisions different from the statements and/or technical features set forth in this document shall immediately void any warranty granted by ST for the ST product or service described herein and shall not create or extend in any manner whatsoever, any liability of ST.

ST and the ST logo are trademarks or registered trademarks of ST in various countries.

Information in this document supersedes and replaces all information previously supplied.

The ST logo is a registered trademark of STMicroelectronics. All other names are the property of their respective owners.

© 2009 STMicroelectronics - All rights reserved

STMicroelectronics group of companies

Australia - Belgium - Brazil - Canada - China - Czech Republic - Finland - France - Germany - Hong Kong - India - Israel - Italy - Japan - Malaysia - Malta - Morocco - Singapore - Spain - Sweden - Switzerland - United Kingdom - United States of America

www.st.com

