

# Transmissive Optical Sensor with Schmitt Trigger Logic Output

## Description

This device consists of a transmissive sensor with a 3-pin connector. The operating wavelength is  $\lambda = 950 \text{ nm}$ . The detector consists of a photologic-IC with Schmitt trigger output.

## Applications

- Detection of opaque material, documents etc.
- Paper position sensor in copy machines
- Position sensor for shaft encoder

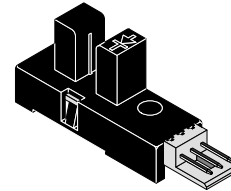

95 10756

## Features

- Output: 'LOW' when infrared beam is not interrupted
- Inverter-open collector
- TLL compatible
- Built-in voltage regulator
- Case plastic polycarbonate-protected against ambient light
- No adjustment necessary
- Applicable connector AMP 171 825-3
- Aperture size 0.5 mm

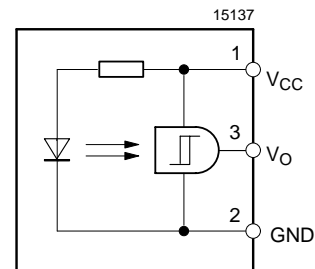

Pin connection

## Handling Precautions

Connect a capacitor C of 100 nF between  $V_{S1}$  and ground in order to stabilize power supply voltage!

## Order Instruction

Ordering Code	Resolution (mm) / Aperture (mm)	Remarks
TCYS6201	/ 0.5	

### Absolute Maximum Ratings ( $T_{amb} = 25^{\circ}\text{C}$ )

Parameter	Test Conditions	Symbol	Value	Unit
Supply voltage		$V_S$	16	V
Output voltage		$V_O$	30	V
Low level output current		$I_{OL}$	20	mA
Operation temperature range		$T_{amb}$	-25 to +85	$^{\circ}\text{C}$
Storage temperature range		$T_{stg}$	-40 to +100	$^{\circ}\text{C}$

### Electrical Characteristics ( $T_{amb} = 25^{\circ}\text{C}$ )

Parameter	Test Conditions	Symbol	Min.	Typ.	Max.	Unit
Supply voltage range		$V_S$	4.5		5.5	V
High level supply current	$V_S = 5\text{ V}^{1)}$	$I_S$		15	30	mA
Low level supply current	$V_S = 5\text{ V}^{2)}$	$I_S$		15	30	mA
High level output voltage	$V_S = 5\text{ V}, R_L = 1\text{ k}\Omega^{1)}$	$V_{OH}$	4.5			V
Low level output voltage	$V_S = 5\text{ V}, I_{OL} = 16\text{ mA}^{2)}$	$V_{OL}$		0.18	0.35	V
Switching frequency	$V_S = 5\text{ V}, R_L = 47\text{ k}\Omega$	f			3	KHz

1) Infrared beam interrupted

2) Infrared beam not interrupted

**Note:** Operating conditions are stabilized after 100  $\mu\text{s}$  of supply voltage turn on.

### Switching Characteristics

Parameter	Test Conditions	Symbol	Typ.	Unit
Rise time	$V_S = 5\text{ V}, R_L = 1\text{ k}\Omega$ (see figure 1)	$t_r$	50.0	ns
Fall time		$t_f$	20.0	ns

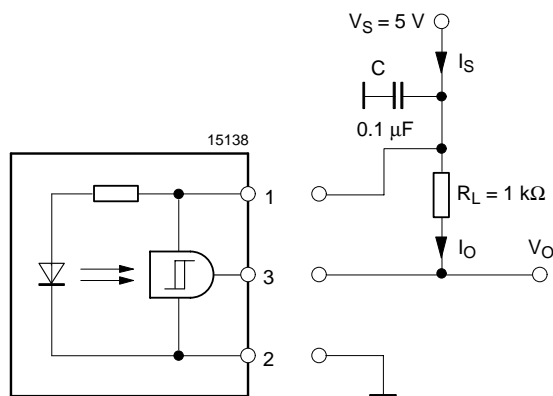

Figure 1. Test circuit and pin connection

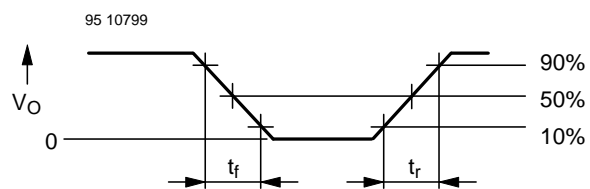

Figure 2. Pulse diagram

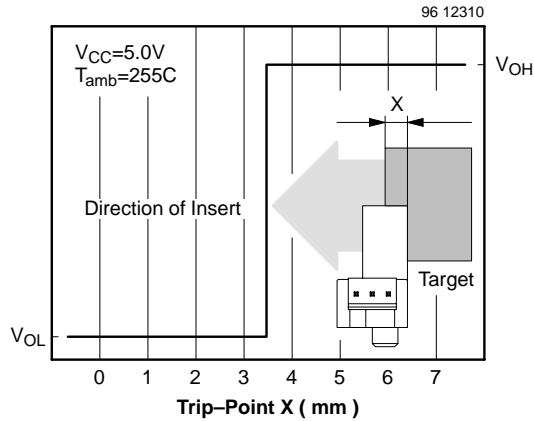

Figure 3. Trip point characteristic

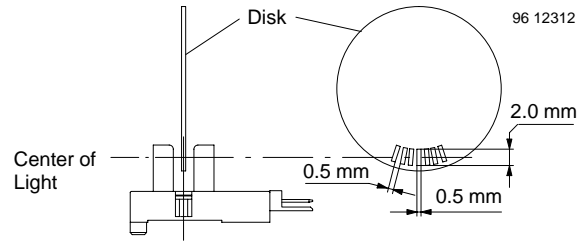

Figure 4. Frequency response

### Typical Characteristics ( $T_{amb} = 25^{\circ}C$ , unless otherwise specified)

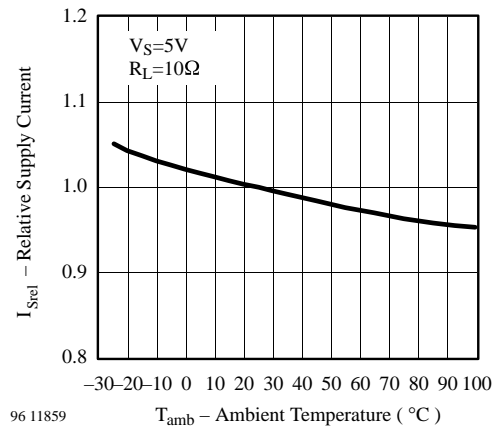

Figure 5. Relative Supply Current vs. Ambient Temperature

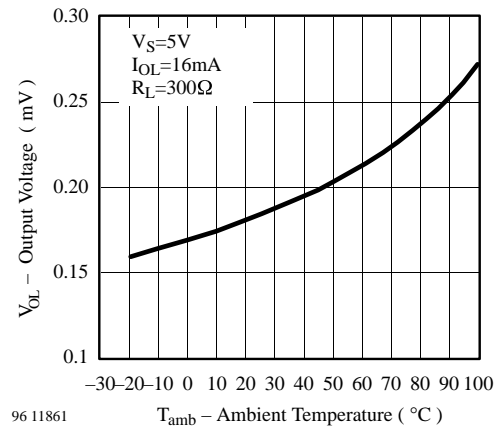

Figure 7. Output Voltage vs. Ambient Temperature

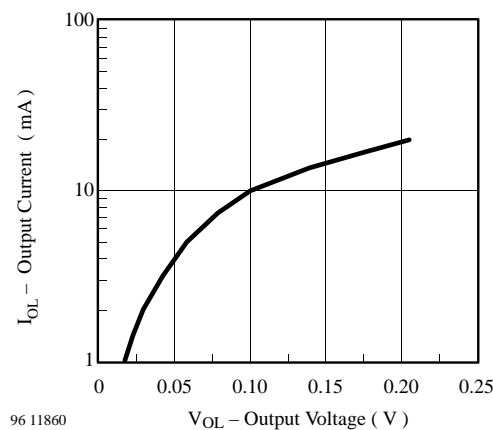
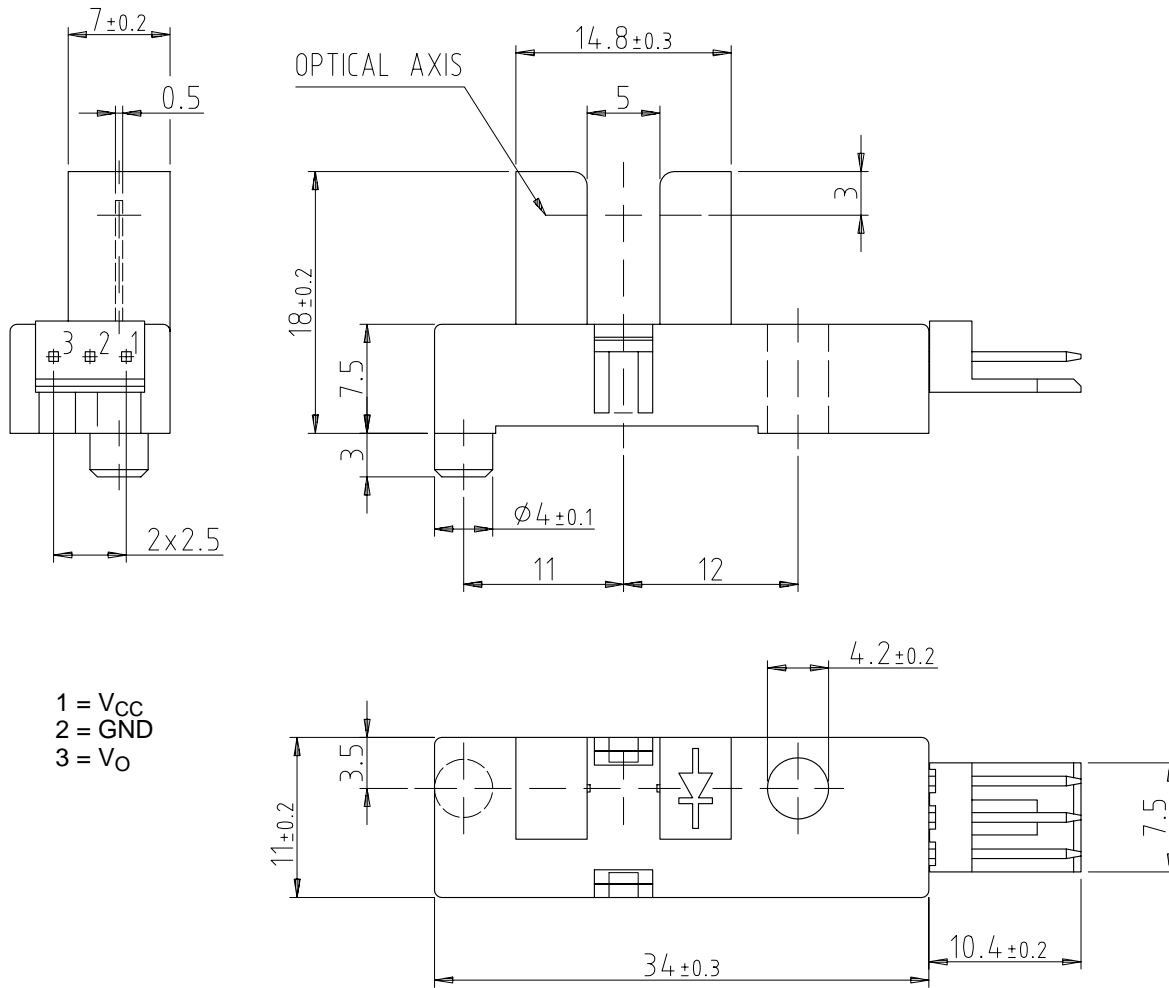
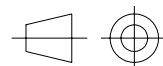

Figure 6. Output Current vs. Output Voltage

## Dimensions of TCYS6201 in mm



weight: ca. 2.74g



technical drawings  
according to DIN  
specifications

96 12100



## Ozone Depleting Substances Policy Statement

It is the policy of **Vishay Semiconductor GmbH** to

1. Meet all present and future national and international statutory requirements.
2. Regularly and continuously improve the performance of our products, processes, distribution and operating systems with respect to their impact on the health and safety of our employees and the public, as well as their impact on the environment.

It is particular concern to control or eliminate releases of those substances into the atmosphere which are known as ozone depleting substances (ODSs).

The Montreal Protocol (1987) and its London Amendments (1990) intend to severely restrict the use of ODSs and forbid their use within the next ten years. Various national and international initiatives are pressing for an earlier ban on these substances.

**Vishay Semiconductor GmbH** has been able to use its policy of continuous improvements to eliminate the use of ODSs listed in the following documents.

1. Annex A, B and list of transitional substances of the Montreal Protocol and the London Amendments respectively
2. Class I and II ozone depleting substances in the Clean Air Act Amendments of 1990 by the Environmental Protection Agency (EPA) in the USA
3. Council Decision 88/540/EEC and 91/690/EEC Annex A, B and C (transitional substances) respectively.

**Vishay Semiconductor GmbH** can certify that our semiconductors are not manufactured with ozone depleting substances and do not contain such substances.

**We reserve the right to make changes to improve technical design and may do so without further notice.**

Parameters can vary in different applications. All operating parameters must be validated for each customer application by the customer. Should the buyer use Vishay Semiconductors products for any unintended or unauthorized application, the buyer shall indemnify Vishay Semiconductors against all claims, costs, damages, and expenses, arising out of, directly or indirectly, any claim of personal damage, injury or death associated with such unintended or unauthorized use.

Vishay Semiconductor GmbH, P.O.B. 3535, D-74025 Heilbronn, Germany  
Telephone: 49 (0)7131 67 2831, Fax number: 49 (0)7131 67 2423



## Disclaimer

All product specifications and data are subject to change without notice.

Vishay Intertechnology, Inc., its affiliates, agents, and employees, and all persons acting on its or their behalf (collectively, "Vishay"), disclaim any and all liability for any errors, inaccuracies or incompleteness contained herein or in any other disclosure relating to any product.

Vishay disclaims any and all liability arising out of the use or application of any product described herein or of any information provided herein to the maximum extent permitted by law. The product specifications do not expand or otherwise modify Vishay's terms and conditions of purchase, including but not limited to the warranty expressed therein, which apply to these products.

No license, express or implied, by estoppel or otherwise, to any intellectual property rights is granted by this document or by any conduct of Vishay.

The products shown herein are not designed for use in medical, life-saving, or life-sustaining applications unless otherwise expressly indicated. Customers using or selling Vishay products not expressly indicated for use in such applications do so entirely at their own risk and agree to fully indemnify Vishay for any damages arising or resulting from such use or sale. Please contact authorized Vishay personnel to obtain written terms and conditions regarding products designed for such applications.

Product names and markings noted herein may be trademarks of their respective owners.