

### Features

- Non-contact switching.
- For direct PC board or dual-in-line socket mounting.
- Fast switching speed.
- Reflective object sensor.

### Application

- FAX machine
- Printer
- COPY machine
- Counter

### Description

The LTH-209-01/LTH-1550-01/LTH-1650-01 reflective object sensors consist of an infrared emitting diode and a NPN silicon phototransistor mounted side by side on converging optical axis in a black plastic housing.

### Package Dimensions

LTH-209-01

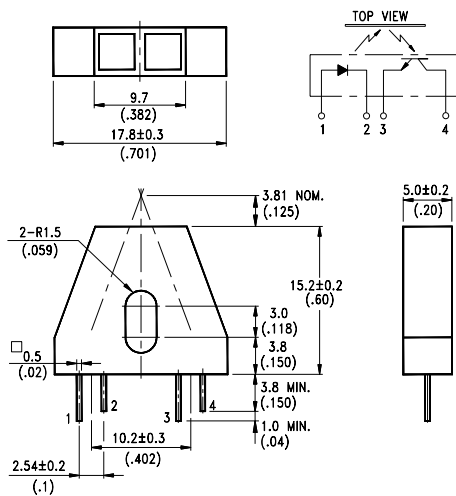

LTH-1550-01

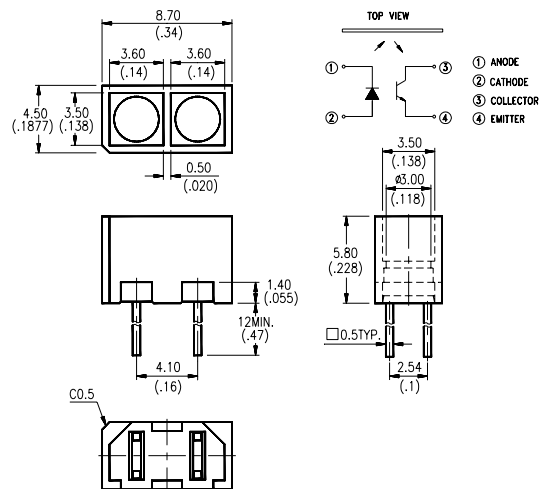

LTH-1650-01

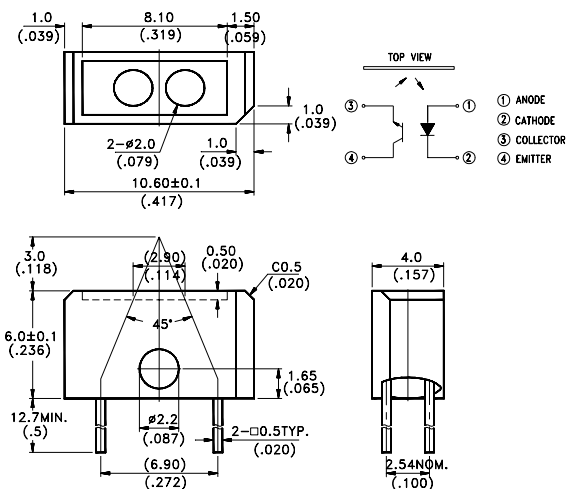

### Notes:

1. All dimensions are in millimeters (inches).
2. Tolerance is  $\pm 0.25$  mm (.010").
3. Lead spacing is measured where the leads emerge from the package.
4. Specifications are subject to change without notice.

## Absolute Maximum Rating at Ta=25°C

Parameter		Symbol	Maximum Rating	Unit
Input LED	Continuous Forward Current	I <sub>F</sub>	60	mA
	Reverse Voltage	V <sub>R</sub>	5	V
	Peak Forward Current (Pulse Wide=10 μs, 300PPS)	I <sub>CP</sub>	1	A
	Power Dissipation	P <sub>D</sub>	75	mW
Output phototransistor	Collector Current	I <sub>C</sub>	20	mA
	Power Dissipation	P <sub>C</sub>	100	mW
	Collector-emitter Voltage	V <sub>CEO</sub>	30	V
	Emitter-collector Voltage	V <sub>ECO</sub>	5	V
Operating Temperature Range		T <sub>opr</sub>	-25°C to + 85°C	
Storage Temperature Range		T <sub>stg</sub>	-40°C to + 100°C	
Lead Soldering Temperature [1.6mm(.063 in.)from body]		T <sub>s</sub>	260°C for 5 Seconds	

## Electrical Optical Characteristics at Ta=25°C

Parameter	Symbol	Part No.	Min.	Typ.	Max.	Unit	Test Condition	Bin No.	
Input LED									
Forward Voltage	V <sub>F</sub>			1.2	1.6	V	I <sub>F</sub> =20mA		
Reverse Current	I <sub>R</sub>				100	μA	V <sub>R</sub> =5V		
Output phototransistor									
Collector Dark Current	I <sub>CEO</sub>				100	nA	V <sub>CE</sub> =10V		
Coupler									
Collector-Emitter Saturation Voltage	V <sub>CE(sat)</sub>	LTH-209-01			0.4	V	I <sub>C</sub> =0.08mA, I <sub>F</sub> =20mA		
		LTH-1550-01			0.4		I <sub>C</sub> =0.10mA, I <sub>F</sub> =20mA		
		LTH-1650-01			0.4		I <sub>C</sub> =0.05mA, I <sub>F</sub> =20mA		
On State Collector Current	I <sub>C(ON)</sub>	LTH-209-01	160			μA	NOTE1		
			200	400	400			NOTE2	BINA
			300		600				BINB
		LTH-1550-01	500		1000		BINC		
			800		1600		BIND		
			LTH-1650-01	100			300	BINA	
		200			600		BINB		
		400			1200		BINC		
		Response Time	Rise Time	t <sub>r</sub>			3	15	μs
Fall Time	t <sub>f</sub>			4	20				

NOTE1: V<sub>CE</sub>=5V, I<sub>F</sub>=20mA, d=3.81MM, 90% Reflectance White Paper

NOTE2: V<sub>CE</sub>=5V, I<sub>F</sub>=20mA, d=3.50MM, 90% Reflectance White Paper

NOTE3: V<sub>CE</sub>=5V, I<sub>F</sub>=20mA, d=3.00MM, 90% Reflectance White Paper

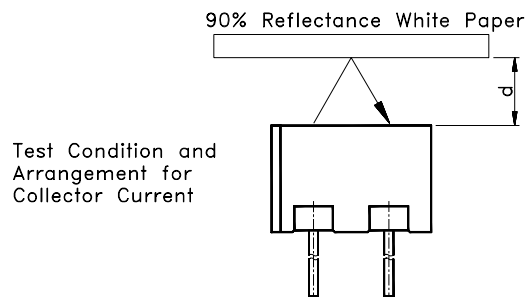

# Typical Electrical/Optical Characteristic Curves (25°C Ambient Temperature Unless Otherwise Noted)

Fig.1 Power Dissipation vs. Ambient Temperature

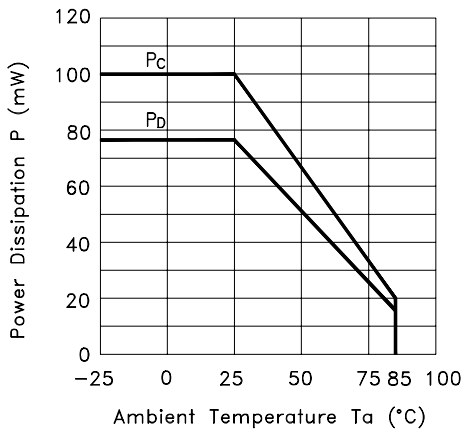

Fig.2 Forward Current vs. Forward Voltage

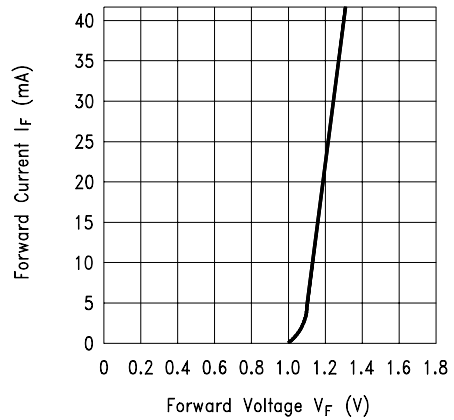

Fig.3 Collector Current vs. Collector-emitter Voltage

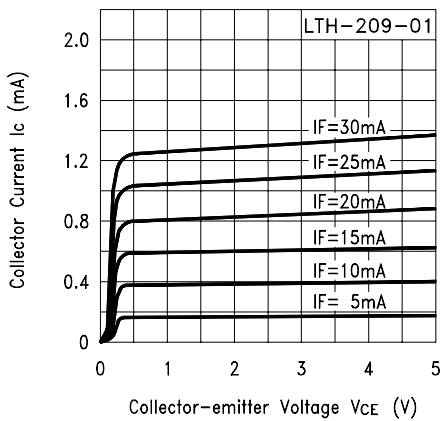

Fig.4 Collector Current vs. Collector-emitter Voltage

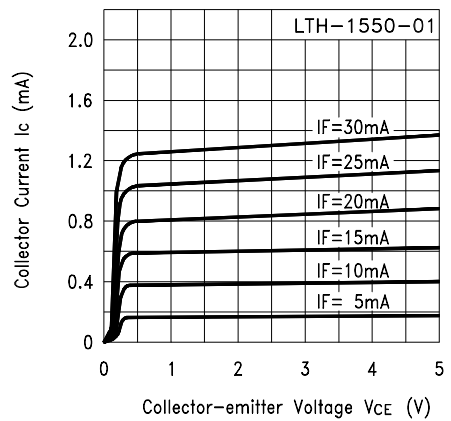

Fig.5 Collector Current vs. Collector-emitter Voltage

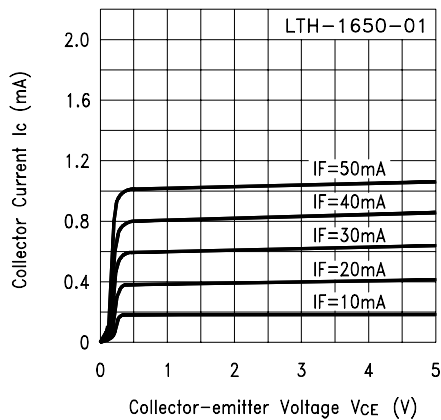
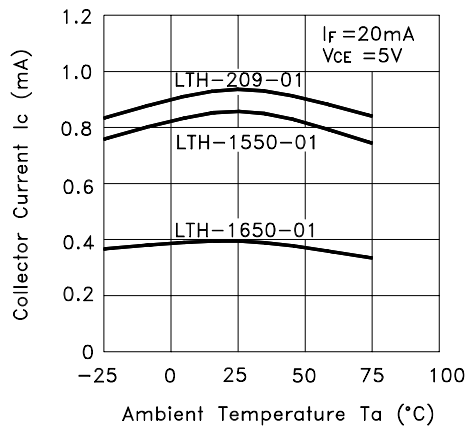

Fig.6 Collector Current vs. Ambient Temperature



# Typical Electrical/Optical Characteristic Curves (25°C Ambient Temperature Unless Otherwise Noted)

Fig.7 Collector-emitter Saturation Voltage vs. Ambient Temperature

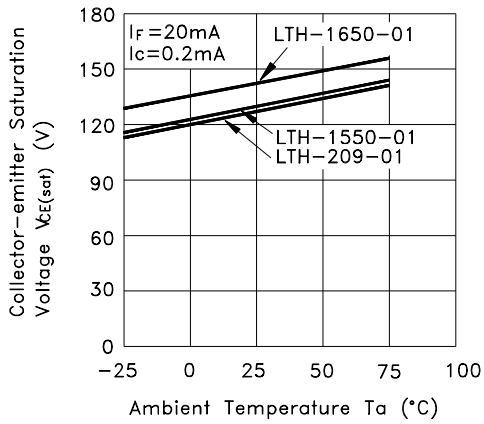

Fig.8 Relative Collector Current vs. Object Distance

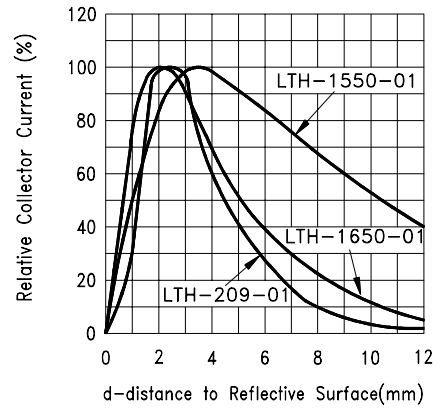
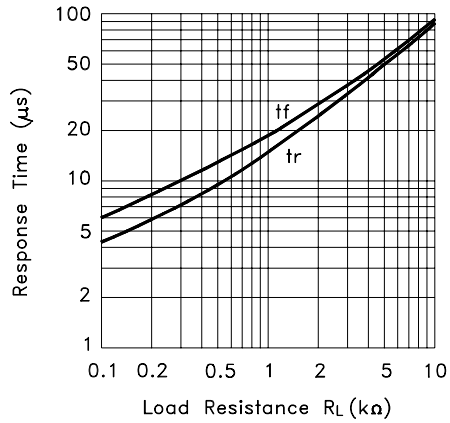

Fig.9 Response Time vs. Load Resistance



Test Circuit for Response Time

