

**Schmitt-Trigger IC im Smart DIL Gehäuse**  
**Schmitt-Trigger IC in Smart DIL Package**  
**Lead (Pb) Free Product - RoHS Compliant**

**SFH 5440**  
**SFH 5441**

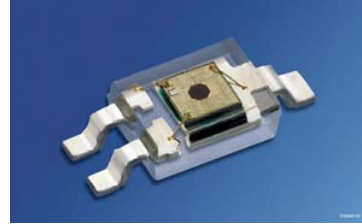

**Wesentliche Merkmale**

- SFH 5440: Ausgang active low
- SFH 5441: Ausgang active high
- Gegurtet lieferbar
- Geeignet für Anwendungen im Bereich von 400 nm bis 1100 nm

**Anwendungen**

- Optischer Schalter
- Pulsformer
- Zähler

**Features**

- SFH 5440: Output active low
- SFH 5441: Output active high
- Available on tape and reel
- Suitable for applications from 400 nm to 1100 nm

**Applications**

- Optical threshold switch
- Pulseformer
- Counter

<b>Typ Type</b>	<b>Bestellnummer Ordering Code</b>	<b>Gehäuse Package</b>
SFH 5440	Q65110A1212	Smart-DIL Gehäuse, GND-Kennzeichnung: breiter Anschluß Smart-DIL package, GND marking: broad lead
SFH 5441	Q65110A2641	

**Grenzwerte** ( $T_A = 25\text{ °C}$ )**Maximum Ratings**

Bezeichnung Parameter	Symbol Symbol	Wert Value	Einheit Unit
Lagertemperatur Storage temperature range	$T_{\text{stg}}$	- 40 ... + 100	°C
Betriebstemperatur Operating temperature range	$T_{\text{op}}$	- 40 ... + 85	°C
Versorgungsspannung Supply voltage	$V_{\text{CC}}$	- 0.5 ... + 20	V
Ausgangsspannung Output voltage	$V_{\text{O}}$	- 0.5 ... + 20	V
Ausgangsstrom Output current	$I_{\text{O}}$	50	mA
Verlustleistung Power dissipation	$P_{\text{tot}}$	175	mW

**Empfohlener Arbeitsbereich****Recommended Operating Conditions**

Bezeichnung Parameter	Symbol Symbol	Wert Value	Einheit Unit
Versorgungsspannung Supply voltage	$V_{\text{CC}}$	4 ... 18	V
Ausgangsstrom Output current	$I_{\text{O}}$	< 16	mA

Zur Stabilisierung der Versorgung wird ein Stützkondensator (angeschlossen zwischen  $V_{\text{CC}}$  und GND) von typ. 0.1  $\mu\text{F}$  empfohlen.

A bypass capacitor, 0.1  $\mu\text{F}$  typical, connected between  $V_{\text{CC}}$  and GND is recommended in order to stabilize power supply line.

**Kennwerte** ( $T_A = 25\text{ °C}$ ,  $V_{\text{CC}} = 5\text{ V}$ )**Characteristics**

Bezeichnung Parameter	Symbol Symbol	Wert Value	Einheit Unit
Ausgangsspannung „high“ Output voltage “high” $I_{\text{O}} = 0$	$V_{\text{OH}}$	$V_{\text{CC}} (> 4.0)$	V
Ausgangsspannung „low“ Output voltage “low” $I_{\text{O}} = 16\text{ mA}$	$V_{\text{OL}}$	0.15 (< 0.4)	V

**Kennwerte** ( $T_A = 25\text{ °C}$ ,  $V_{CC} = 5\text{ V}$ )  
**Characteristics** (cont'd)

Bezeichnung Parameter	Symbol Symbol	Wert Value	Einheit Unit
Stromaufnahme, $E = 0$ Supply current $V_{CC} = 5\text{ V}$ $V_{CC} = 18\text{ V}$	$I_{CC}$	3.3 (< 5) 5.0	mA
Schaltsschwelle, $\lambda = 950\text{ nm}$ Threshold "ON" SFH 5440: "H" → "L" SFH 5441: "L" → "H"	$E_{e, ON}$	170 (< 320)	$\mu\text{W}/\text{cm}^2$
Hysteresese Hysteresis	$E_{e, OFF}/E_{e, ON}$	0.6 (0.5 ... 0.9)	–
Halbwinkel Half angle	$\varphi$	$\pm 60$	Grad degr.
Anstiegszeit 10% bis 90% Rise time 10% to 90% $R_L = 280\ \Omega$ , $E_e = 600\ \mu\text{W}/\text{cm}^2$ , $\lambda = 950\text{ nm}$	$t_r$	100	ns
Abfallzeit 90% bis 10% Fall time 90% to 10% $R_L = 280\ \Omega$ , $E_e = 600\ \mu\text{W}/\text{cm}^2$ , $\lambda = 950\text{ nm}$	$t_f$	100	ns
Ausgangsverzögerungszeit Propagation delay time "H" → "L" $R_L = 280\ \Omega$ , $E_e = 600\ \mu\text{W}/\text{cm}^2$ , $\lambda = 950\text{ nm}$	$t_{PHL}$	5 (< 15)	$\mu\text{s}$
Ausgangsverzögerungszeit Propagation delay time "L" → "H" $R_L = 280\ \Omega$ , $E_e = 600\ \mu\text{W}/\text{cm}^2$ , $\lambda = 950\text{ nm}$	$t_{PLH}$	5 (< 15)	$\mu\text{s}$

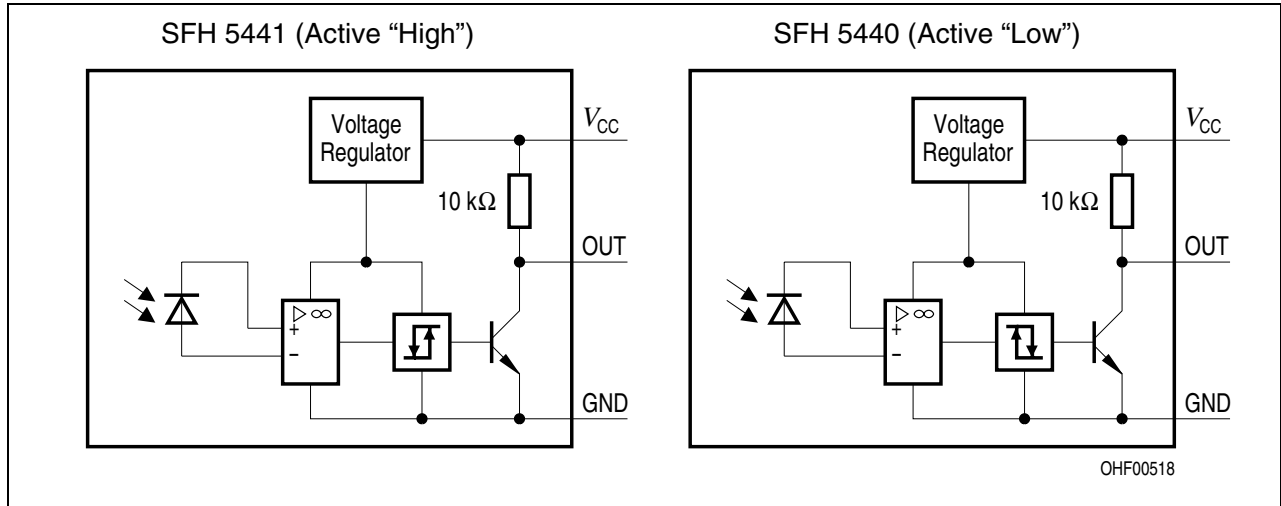

Figure 1 Block Diagram

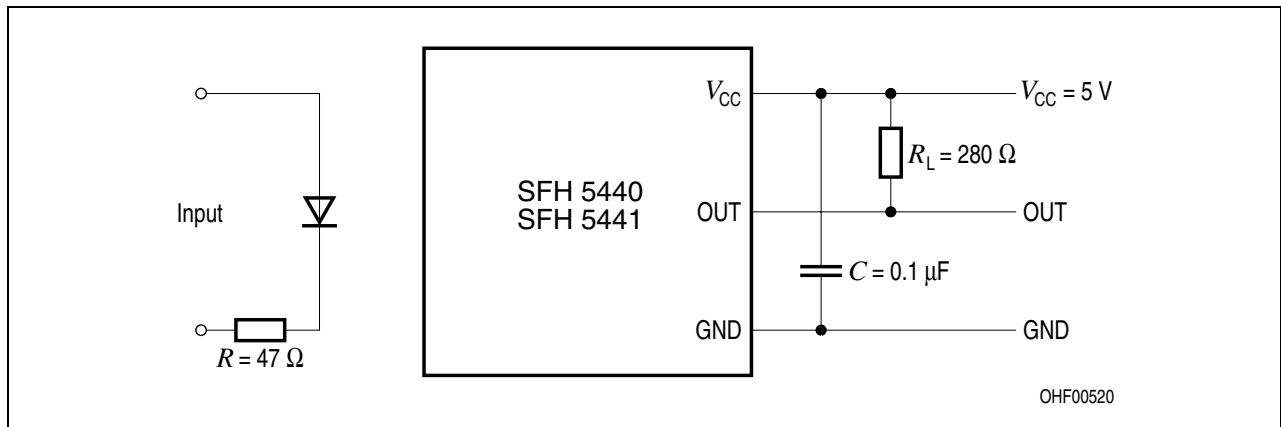

Figure 2 Test Circuit for Switching and Response Time

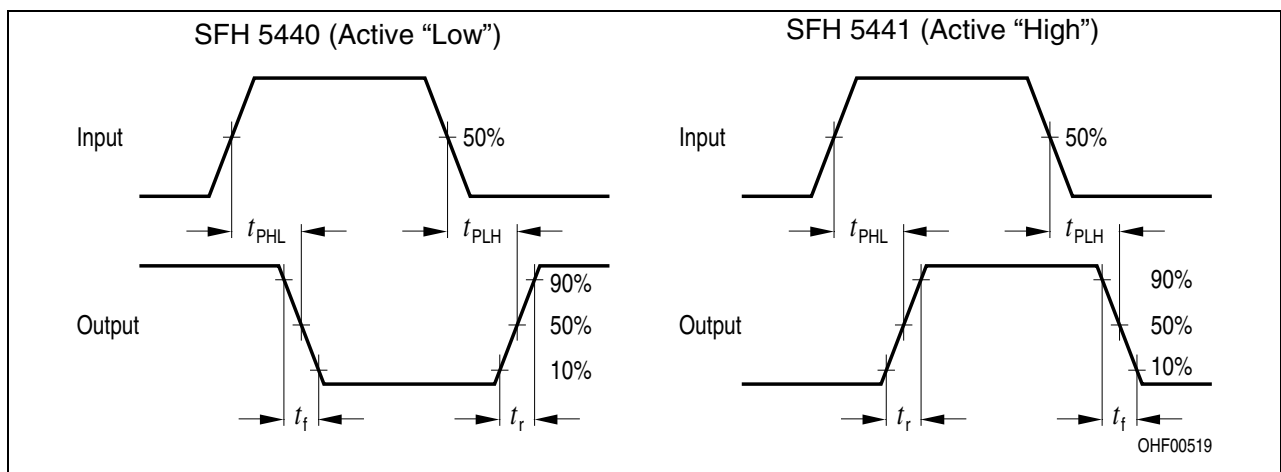
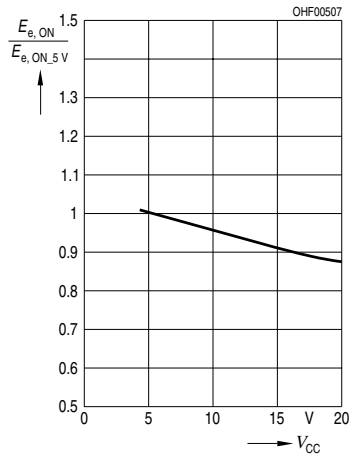

Figure 3 Switching Time Definitions

**Relative Threshold**

$$E_{e, ON} / E_{e, ON} (V_{CC} = 5 \text{ V}) = f(V_{CC})$$



**Supply Current**

$$I_{CC} = f(V_{CC})$$

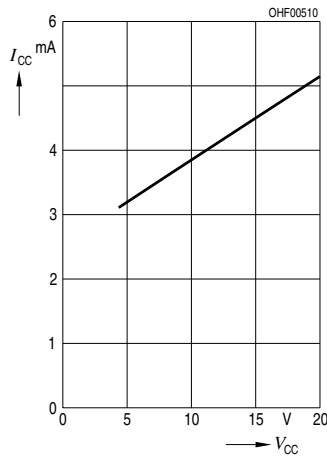

**Total Power Dissipation**

$$P_{tot} = f(T_A)$$

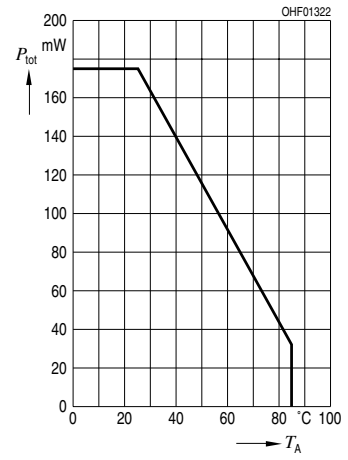

**Output Voltage**

$$V_{OL} = f(I_{OUT}, V_{CC})$$

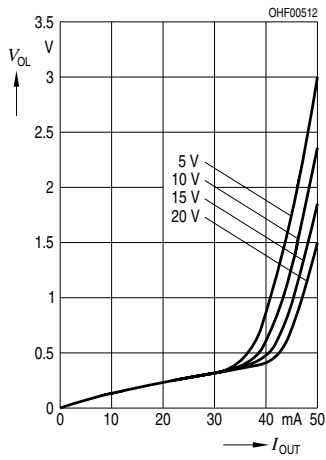

**Supply Current vs. Ambient Temperature**

$$I_{CC} = f(T_A, V_{CC})$$

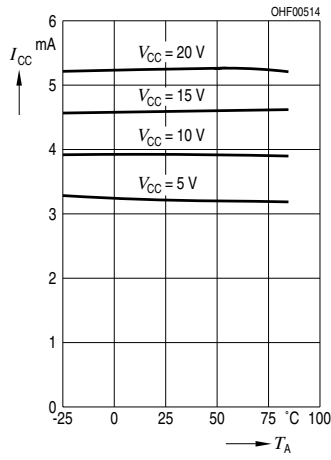

**Maßzeichnung  
Package Outlines**

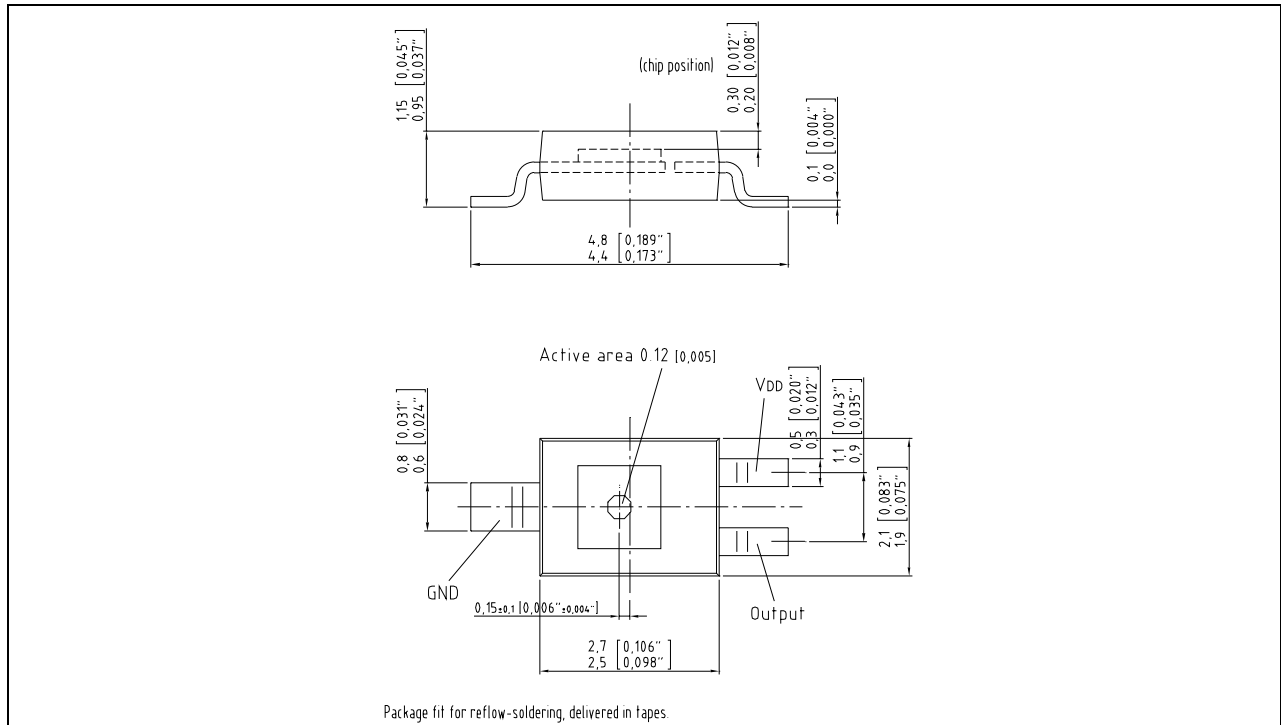

Maße in mm (inch) / Dimensions in mm (inch).

**Empfohlenes Lötpaddesign  
Recommended Solderpad Design**

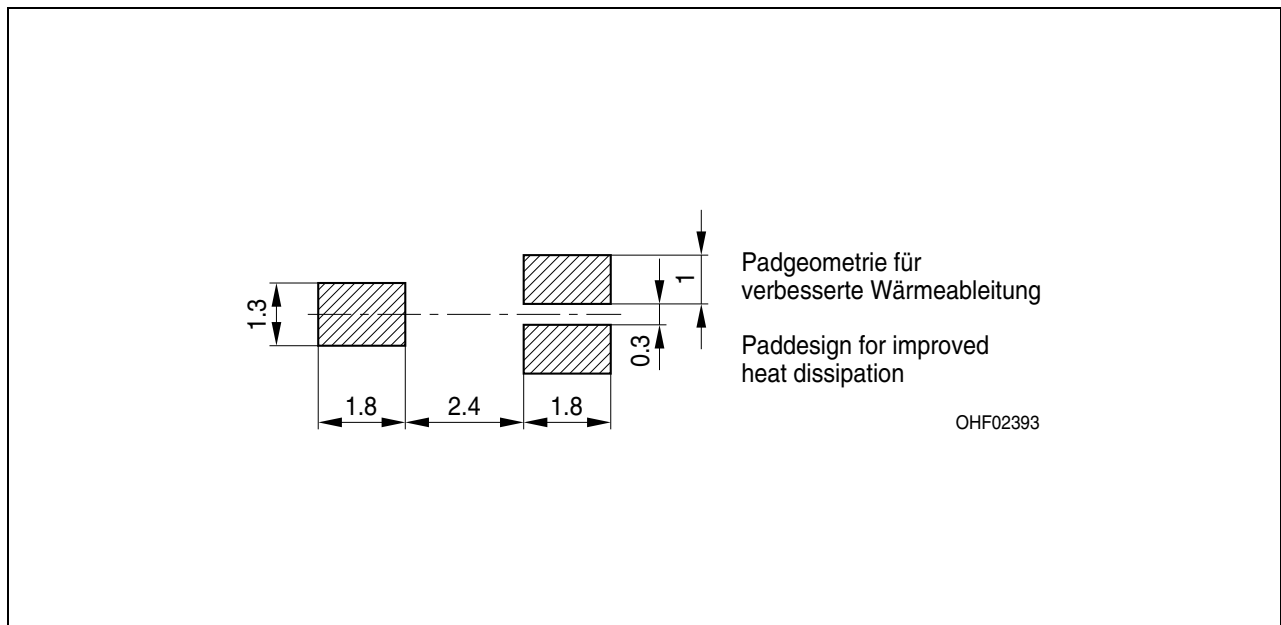

**Lötbedingungen****Soldering Conditions****Reflow Lötprofil für bleifreies Löten****Reflow Soldering Profile for lead free soldering**

Vorbehandlung nach JEDEC Level 4

Preconditioning acc. to JEDEC Level 4

(nach J-STD-020C)

(acc. to J-STD-020C)

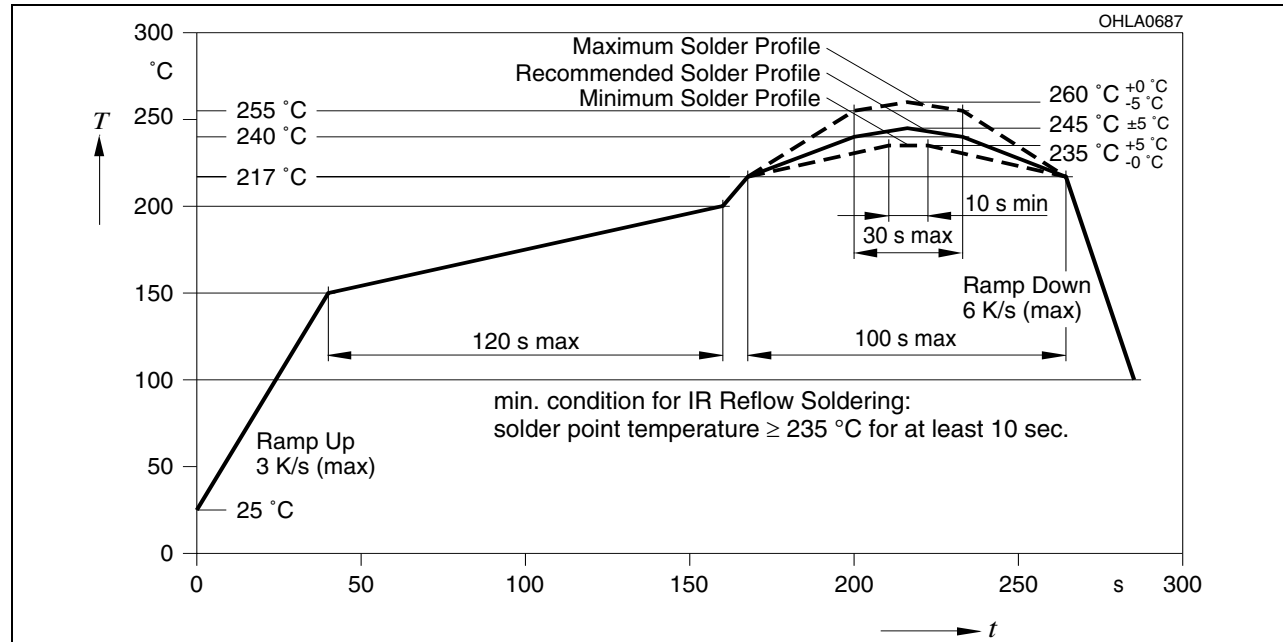

Published by  
**OSRAM Opto Semiconductors GmbH**  
 Wernerwerkstrasse 2, D-93049 Regensburg  
[www.osram-os.com](http://www.osram-os.com)  
 © All Rights Reserved.

EU RoHS and China RoHS compliant product



此产品符合欧盟 RoHS 指令的要求；

按照中国的相关法规和标准，不含有毒有害物质或元素。

The information describes the type of component and shall not be considered as assured characteristics. Terms of delivery and rights to change design reserved. Due to technical requirements components may contain dangerous substances. For information on the types in question please contact our Sales Organization.

**Packing**

Please use the recycling operators known to you. We can also help you – get in touch with your nearest sales office. By agreement we will take packing material back, if it is sorted. You must bear the costs of transport. For packing material that is returned to us unsorted or which we are not obliged to accept, we shall have to invoice you for any costs incurred.

**Components used in life-support devices or systems must be expressly authorized for such purpose!** Critical components<sup>1</sup>, may only be used in life-support devices or systems<sup>2</sup> with the express written approval of OSRAM OS.

<sup>1</sup> A critical component is a component used in a life-support device or system whose failure can reasonably be expected to cause the failure of that life-support device or system, or to affect its safety or effectiveness of that device or system.

<sup>2</sup> Life support devices or systems are intended (a) to be implanted in the human body, or (b) to support and/or maintain and sustain human life. If they fail, it is reasonable to assume that the health of the user may be endangered.