

# SDP8004/8014

## Optoschmitt Detector Totem-Pole Output

### FEATURES

- Side-looking plastic package
- 55° (nominal) acceptance angle
- TTL/LSTTL/CMOS compatible
- Totem-pole output
- Buffer (SDP8004) or inverting (SDP8014) logic available
- High noise immunity output
- Mechanically and spectrally matched to SEP8506 and SEP8706 infrared emitting diodes

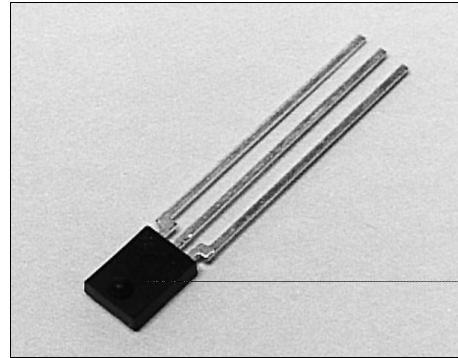

INFRA-8.TIF

### DESCRIPTION

The SDP8004/8014 series consists of a high speed IC molded in a side- looking black plastic package to minimize the effect of visible ambient light. The detector incorporates a Schmitt trigger which provides pulse shaping and hysteresis for noise immunity. The totem-pole output is well- suited for applications which require fast transition times. The output can drive 10 TTL loads. Output rise and fall times are independent of rate of change of incident light. Detector sensitivity has been internally temperature compensated. For additional output configuration options refer to SDP8304/8314 and SDP8604/8614.

### Device Polarity:

- Buffer - Output is HI when incident light intensity is above the turn- on threshold level.
- Inverter - Output is LO when incident light intensity is above the turn- on threshold level.

### OUTLINE DIMENSIONS in inches (mm)

Tolerance	3 plc decimals	±0.005(0.12)
	2 plc decimals	±0.020(0.51)

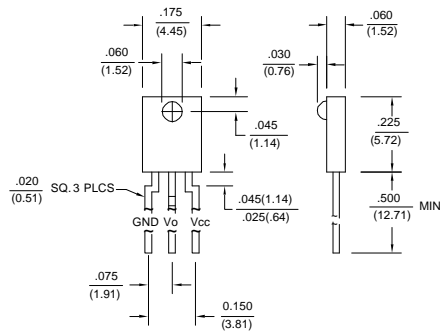

DIM\_026.d54

# SDP8004/8014

## Optoschmitt Detector Totem-Pole Output

### ELECTRICAL CHARACTERISTICS (-40°C to +85°C unless otherwise noted)

PARAMETER	SYMBOL	MIN	TYP	MAX	UNITS	TEST CONDITIONS
Operating Supply Voltage	V <sub>CC</sub>	4.5		7.0	V	T <sub>A</sub> =25°C
Turn-on Threshold Irradiance <sup>(2)</sup> SDP8004-301, SDP8014-301	E <sub>ET(+)</sub>	0.06		0.37	mW/cm <sup>2</sup>	V <sub>CC</sub> =5 V T <sub>A</sub> =25°C
Hysteresis <sup>(3)</sup>	HYST	33		67	%	
Supply Current	I <sub>CC</sub>			15.0	mA	V <sub>CC</sub> =5.5 V E <sub>e</sub> =0 Or 3.0 mW/cm <sup>2</sup>
High Level Output Voltage SDP8004 SDP8014	V <sub>OH</sub>	2.4 2.4			V	V <sub>CC</sub> =4.5 V, I <sub>OH</sub> =0.8 mA E <sub>e</sub> =3.0 mW/cm <sup>2</sup> E <sub>e</sub> =0
Low Level Output Voltage SDP8004 SDP8014	V <sub>OL</sub>			0.4 0.4	V	V <sub>CC</sub> =5.5 V, I <sub>OL</sub> =12.8 mA E <sub>e</sub> =0 E <sub>e</sub> =3.0 mW/cm <sup>2</sup>
Short Circuit Output Current SDP8004 SDP8014	I <sub>OS</sub>	-20 -20		-100 -100	mA	V <sub>CC</sub> =5.5 V, Output=GND E <sub>e</sub> =3.0 mW/cm <sup>2</sup> E <sub>e</sub> =0
Operate Point Temperature Coefficient	O <sub>PTC</sub>		-0.76		%/°C	Emitter @ Constant Temperature
Output Rise Time, Output Fall Time	t <sub>r</sub> , t <sub>f</sub>		70		ns	V <sub>CC</sub> =5 V, T <sub>A</sub> =25°C E <sub>e</sub> =0 or 3.0 mW/cm <sup>2</sup> f=10.0 kHz, D.C.=50% R <sub>L</sub> =8 TTL Loads
Propagation Delay, Low-High, High-Low	t <sub>PLH</sub> , t <sub>PHL</sub>		2.5	5.0	µs	V <sub>CC</sub> =5 V, T <sub>A</sub> =25°C E <sub>e</sub> =0.5 mW/cm <sup>2</sup> f=10.0 kHz, D.C.=50% R <sub>L</sub> =8 TTL Loads
Clock Frequency				100	kHz	R <sub>L</sub> =390 Ω, C <sub>L</sub> =50 pF

#### Notes

- It is recommended that a bypass capacitor, 0.1 µF typical, be added between V<sub>CC</sub> and GND near the device in order to stabilize power supply line.
- The radiation source is an IRED with a peak wavelength of 935 nm.
- Hysteresis is defined as the difference between the operating and release threshold intensities, expressed as a percentage of the operate threshold intensity.

### ABSOLUTE MAXIMUM RATINGS

(25°C Free-Air Temperature unless otherwise noted)

Supply Voltage	7 V <sup>(1)</sup>
Duration of Output Short to V <sub>CC</sub> or Ground	1.0 sec
High Level Output Current	1.0 mA
Irradiance	25 mW/cm <sup>2</sup>
Operating Temperature Range	-40°C to 85°C
Storage Temperature Range	-40°C to 85°C
Soldering Temperature (5 sec)	240°C

#### Notes

- Derate linearly from 25°C to 5.5 V at 85°C.

### SCHEMATIC SDP8004 BUFFER, TOTEM-POLE

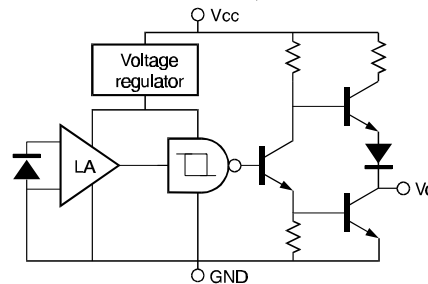

Honeywell reserves the right to make changes in order to improve design and supply the best products possible.

# Honeywell

185

# SDP8004/8014

Optoschmitt Detector  
Totem-Pole Output

## SCHEMATIC

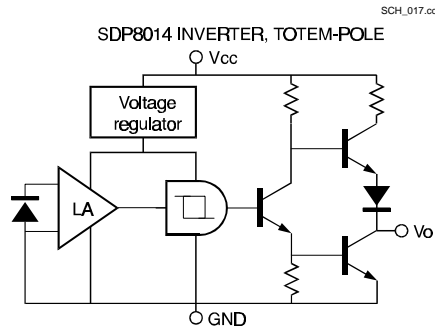

## SWITCHING TIME TEST CIRCUIT

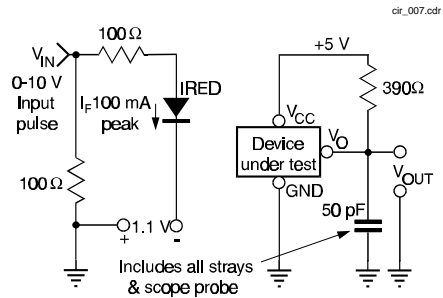

## SWITCHING WAVEFORM FOR BUFFERS

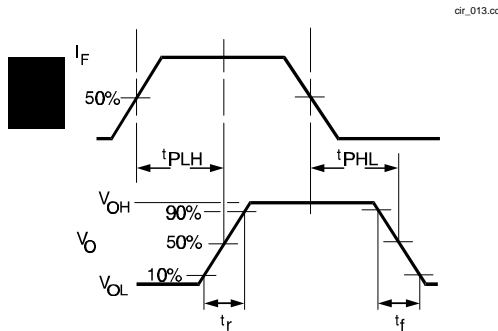

## SWITCHING WAVEFORM FOR INVERTERS

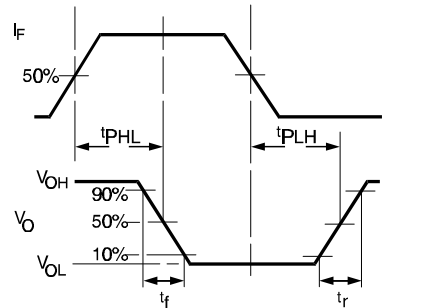

Fig. 1 Responsivity vs Angular Displacement

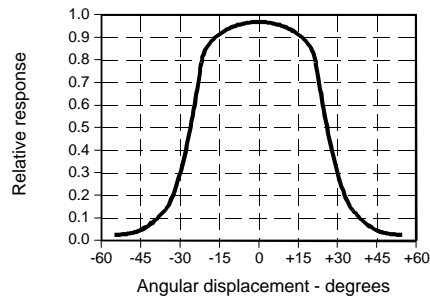
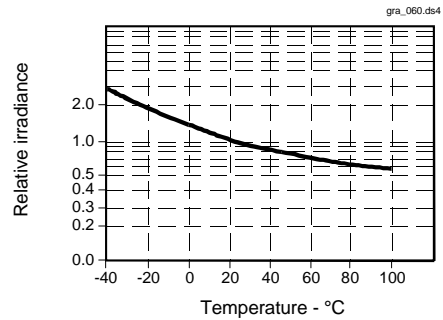

Fig. 2 Threshold Irradiance vs Temperature



# SDP8004/8014

## Optoschmitt Detector

### Totem-Pole Output

Fig. 3 Output Rise Time ( $t_r$ ) and Output Fall Time ( $t_f$ ) vs Temperature

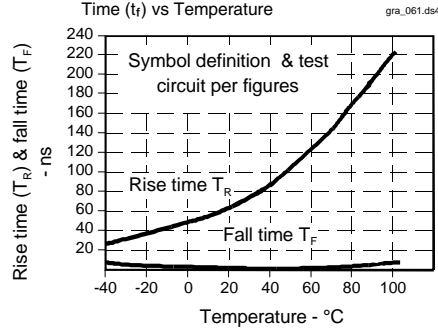

Fig. 4 Delay Time vs Temperature

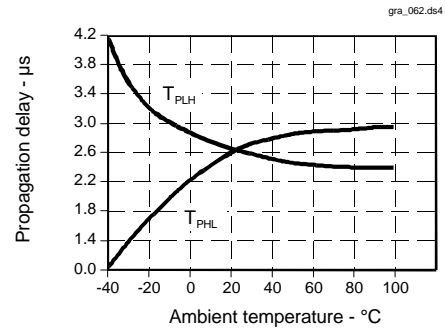
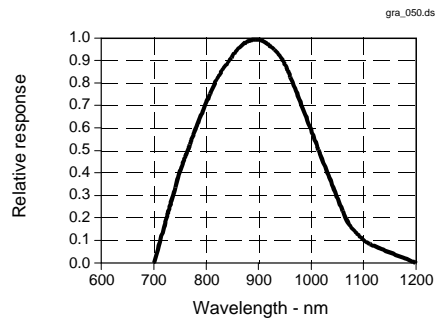

Fig. 5 Spectral Responsivity



All Performance Curves Show Typical Values

Honeywell reserves the right to make changes in order to improve design and supply the best products possible.

# Honeywell