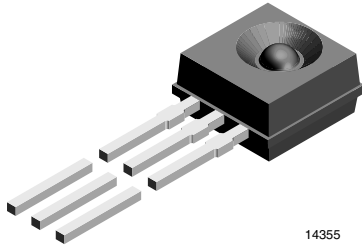


Silicon Photo Schmitt Trigger with Digital Output, RoHS Compliant



DESCRIPTION

TEKS5400 is a photo Schmitt Trigger with high radiant sensitivity, molded in a plastic package with side view lens and daylight blocking filter. Filter bandwidth is matched with 900 nm to 950 nm IR emitters.

FEATURES

- Package type: leaded
- Package form: side view lens
- Dimensions (L x W x H in mm): 5 x 2.65 x 5
- High radiant sensitivity
- Daylight blocking filter matched with 940 nm IR emitters
- Angle of half sensitivity: $\varphi = \pm 30^\circ$
- Supply voltage range: 4.5 V to 16 V
- Low current consumption: 2 mA
- High EMI protection
- TTL and CMOS compatible
- Open collector output
- Output signal level active "low"
- Package matched with IR emitter series TSKS5400
- Lead (Pb)-free component in accordance with RoHS 2002/95/EC and WEEE 2002/96/EC


RoHS
COMPLIANT

APPLICATIONS

- Shaft encoder
- Transmissive sensor
- Reflective sensor

PRODUCT SUMMARY

COMPONENT	V_{OL} (V)	φ (deg)	$\lambda_{0.5}$ (nm)
TEKS5400-FSZ	0.2	± 30	600 to 1020
TEKS5400-FGZ	0.2	± 30	600 to 1020

Note

Test conditions see table "Basic Characteristics"

ORDERING INFORMATION

ORDERING CODE	PACKAGING	REMARKS	PACKAGE FORM
TEKS5400-FSZ	Tape and ammpack	MOQ: 2000 pcs, 2000 pcs/ammopack, pitch: 1.27 mm	Side view lens
TEKS5400-FGZ	Tape and ammpack	MOQ: 2000 pcs, 2000 pcs/ammopack, pitch: 2.00 mm	Side view lens

Note

MOQ: minimum order quantity

ABSOLUTE MAXIMUM RATINGS

PARAMETER	TEST CONDITION	SYMBOL	VALUE	UNIT
Supply voltage		V_{S1}	18	V
Output current		I_O	20	mA
Power dissipation		P_V	100	mW
Junction temperature		T_j	100	$^\circ\text{C}$
Operating temperature range		T_{amb}	- 25 to + 85	$^\circ\text{C}$
Storage temperature range		T_{stg}	- 40 to + 100	$^\circ\text{C}$
Soldering temperature	$t \leq 5$ s, 2 mm from body	T_{sd}	260	$^\circ\text{C}$
Thermal resistance junction/ambient	J-STD-051, soldered on PCB	R_{thJA}	270	K/W

Note

$T_{amb} = 25$ $^\circ\text{C}$, unless otherwise specified

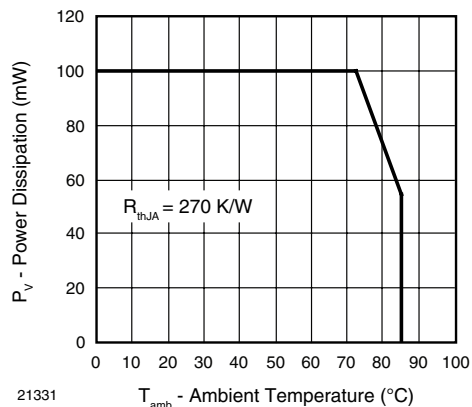


Fig. 1 - Power Dissipation Limit vs. Ambient Temperature

HANDLING PRECAUTIONS

Caution: connect a capacitor C of 100 nF between V_{S1} and ground!

BASIC CHARACTERISTICS						
PARAMETER	TEST CONDITION	SYMBOL	MIN.	TYP.	MAX.	UNIT
Supply voltage		V_{S1}/V_{S2}	4.5		16	V
Supply current	$V_{S1} = 16\text{ V}$	I_{S1}		2	5	mA
Irradiance for threshold "on"	$\lambda = 950\text{ nm}, V_{S1} = 5\text{ V}$	$E_{e\text{on}}$	25	50	85	$\mu\text{W}/\text{cm}^2$
Hysteresis	$V_{S1} = 5\text{ V}$	$E_{e\text{off}}/E_{e\text{on}}$		80		%
Angle of half sensitivity		φ		± 30		deg
Wavelength of peak sensitivity		λ_p		920		nm
Range of spectral bandwidth		$\lambda_{0.5}$		600 to 1020		nm
Output voltage	$I_{OL} = 16\text{ mA}, V_{S1} = 5\text{ V}, E_e \geq E_{e\text{on}}$	V_{OL}		0.2	0.4	V
High level output current	$V_{S1} = V_{S2} = 16\text{ V}, I_F = 0$	I_{OH}			1	μA
Rise time	$V_{S1} = V_{S2} = 5\text{ V}, R_L = 1\text{ k}\Omega, E_e = 3 \times E_{e\text{on}}, \lambda = 950\text{ nm}$	t_r		100		ns
Fall time	$V_{S1} = V_{S2} = 5\text{ V}, R_L = 1\text{ k}\Omega, E_e = 3 \times E_{e\text{on}}, \lambda = 950\text{ nm}$	t_f		20		ns
Turn-on time	$V_{S1} = V_{S2} = 5\text{ V}, R_L = 1\text{ k}\Omega, E_e = 3 \times E_{e\text{on}}, \lambda = 950\text{ nm}$	t_{on}		1.5		μs
Turn-off time	$V_{S1} = V_{S2} = 5\text{ V}, R_L = 1\text{ k}\Omega, E_e = 3 \times E_{e\text{on}}, \lambda = 950\text{ nm}$	t_{off}		3		μs
Cut off frequency	$V_{S1} = V_{S2} = 5\text{ V}, R_L = 1\text{ k}\Omega, E_e = 3 \times E_{e\text{on}}, \lambda = 950\text{ nm}$	f_c		200		kHz

Note

$T_{\text{amb}} = 25\text{ }^\circ\text{C}$, unless otherwise specified

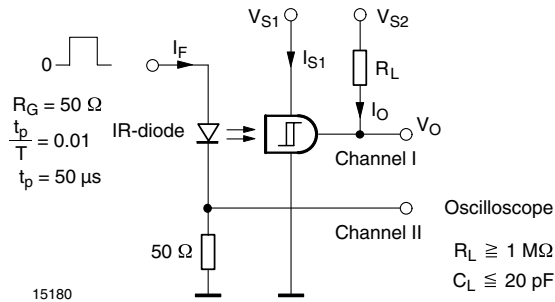


Fig. 2 - Test Circuit

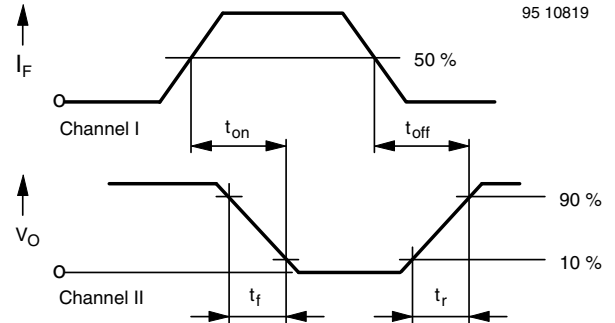


Fig. 3 - Pulse Diagram

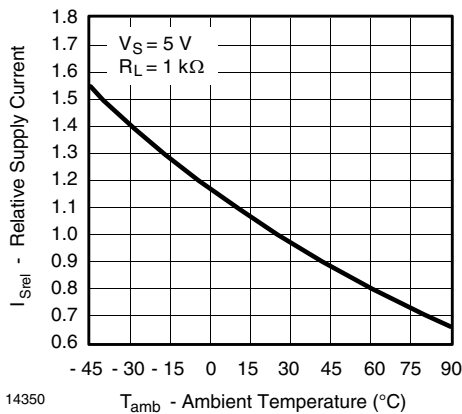
BASIC CHARACTERISTICS
 $T_{amb} = 25\text{ }^{\circ}\text{C}$, unless otherwise specified


Fig. 4 - Rel. Supply Current vs. Ambient Temperature

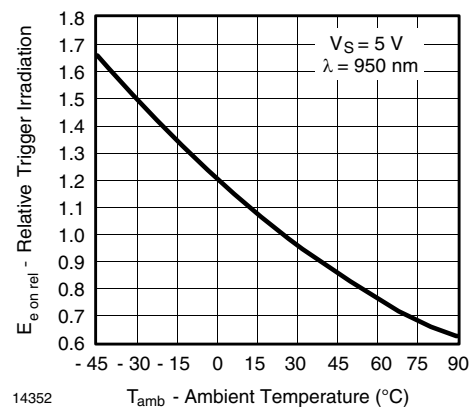


Fig. 6 - Relative Trigger Irradiation vs. Ambient Temperature

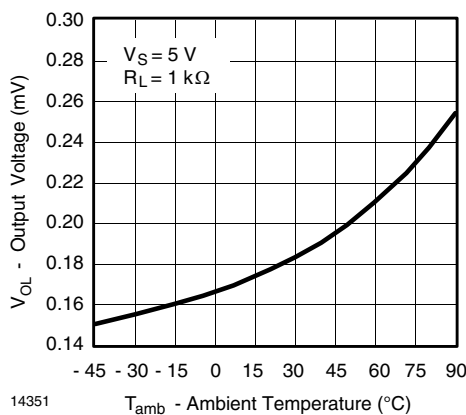


Fig. 5 - Output Voltage vs. Ambient Temperature

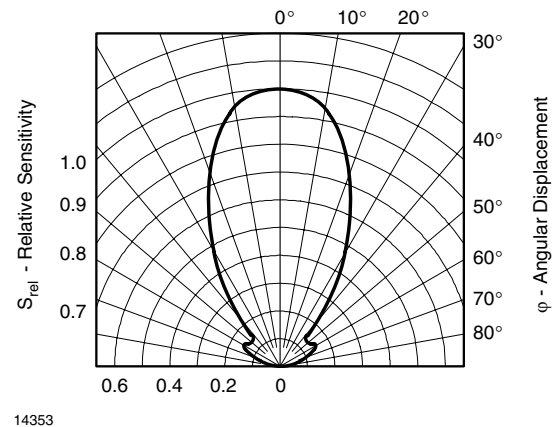
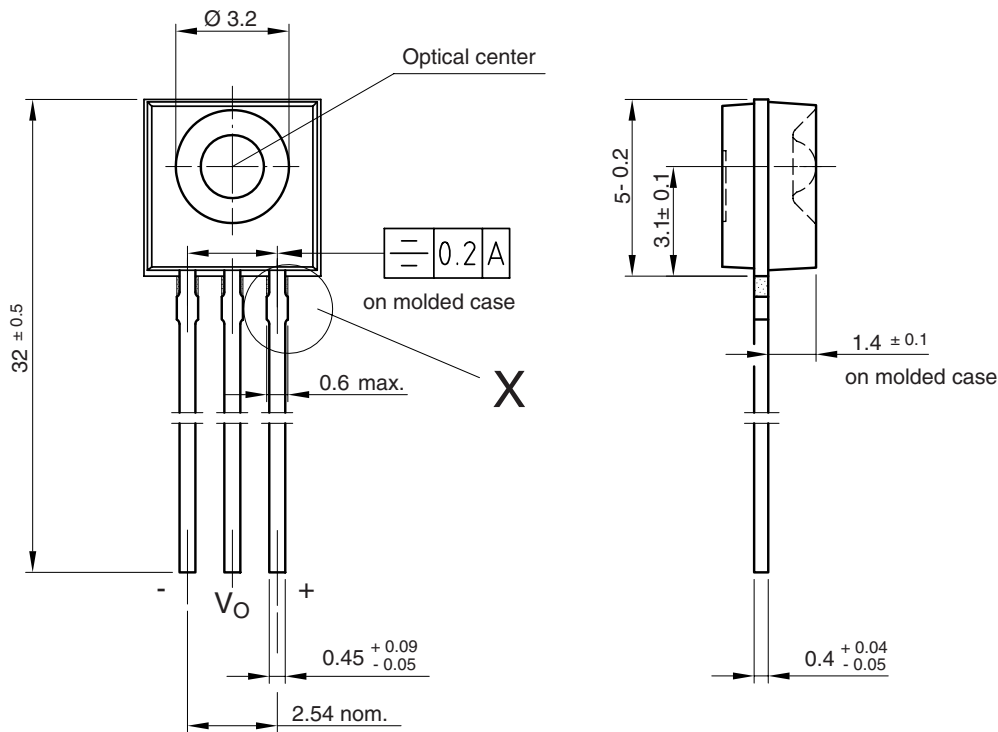
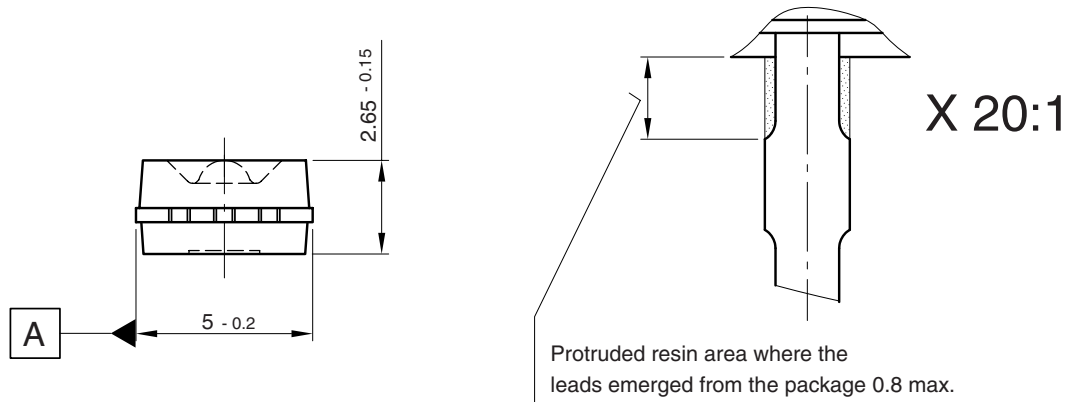


Fig. 7 - Relative Radiant Sensitivity vs. Angular Displacement

PACKAGE DIMENSIONS in millimeters



technical drawings according to DIN specifications

Drawing-No.: 6.544-5309.51-4
 Issue: 8; 16.05.02
 14346



Disclaimer

All product specifications and data are subject to change without notice.

Vishay Intertechnology, Inc., its affiliates, agents, and employees, and all persons acting on its or their behalf (collectively, "Vishay"), disclaim any and all liability for any errors, inaccuracies or incompleteness contained herein or in any other disclosure relating to any product.

Vishay disclaims any and all liability arising out of the use or application of any product described herein or of any information provided herein to the maximum extent permitted by law. The product specifications do not expand or otherwise modify Vishay's terms and conditions of purchase, including but not limited to the warranty expressed therein, which apply to these products.

No license, express or implied, by estoppel or otherwise, to any intellectual property rights is granted by this document or by any conduct of Vishay.

The products shown herein are not designed for use in medical, life-saving, or life-sustaining applications unless otherwise expressly indicated. Customers using or selling Vishay products not expressly indicated for use in such applications do so entirely at their own risk and agree to fully indemnify Vishay for any damages arising or resulting from such use or sale. Please contact authorized Vishay personnel to obtain written terms and conditions regarding products designed for such applications.

Product names and markings noted herein may be trademarks of their respective owners.