

66056**SINGLE/DUAL CHANNEL, HERMETICALLY SEALED,
VERY HIGH SPEED OPTOCOUPLER**

09/22/03

Features:

- DSCC Approved 8102802PX (Dual Channel), and 5962-9085501HPX (single channel)
- 10 MHz bandwidth typical
- 1500 Vdc isolation test voltage
- TTL compatible input and output
- High radiation immunity
- Faraday shield to provide high common mode rejection

Applications:

- Military and space
- Voltage level shifting
- Isolated receiver input
- Communication systems
- Medical systems

DESCRIPTION

The **66056** single and dual channel optocouplers consist of LED's optically coupled to high speed, high gain inverting detector gates. Maximum isolation can be achieved while providing TTL outputs capable of switching with propagation delays of 55ns typical. The 66056 is available in military temperature range and military temperature with 100% device screening. The devices are built in eight-pin dual-in-line, hermetically sealed packages and provide high input to output DC isolation.

ABSOLUTE MAXIMUM RATINGS

Total Power Dissipation (each channel).....	175mW
Peak Forward Input Current (each channel) (1ms duration)	40mA
Average Forward Input Current (each channel) (Note 1)	20mA
Input Power Dissipation (each channel)	35mW
Reverse Input Voltage (each channel)	5V
Supply voltage - V_{CC} (1 minute maximum).....	7V
Output Current - I_O (each channel)	25mA
Output Power Dissipation (each channel)	40mW
Output Voltage - V_O (each channel)	7V
Storage Temperature.....	-65°C to +150°C
Operating Free-Air Temperature Range	-55°C to +125°C
Lead Solder Temperature (10 seconds, 1/16" below seating plane).....	260°C

NOTES:

1. Derate I_F at 0.20mA/°C above 25°C.

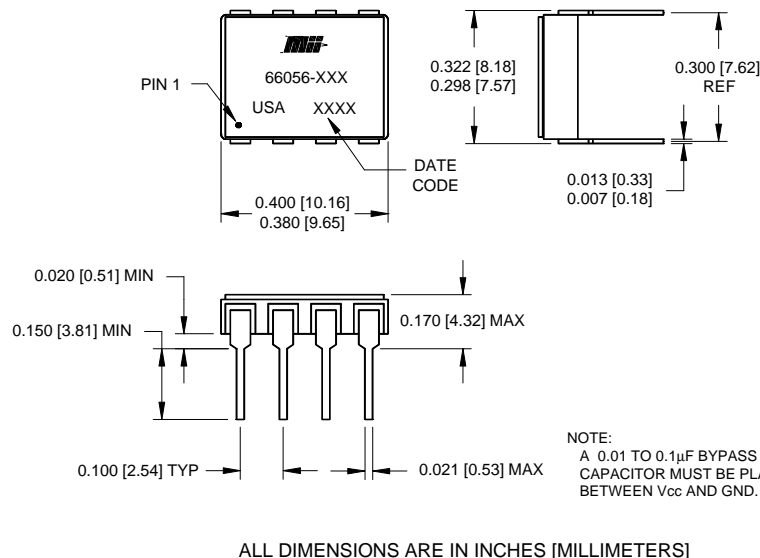
Package Dimensions

NOTE:
A 0.01 TO 0.1μF BYPASS
CAPACITOR MUST BE PLACED
BETWEEN V_{CC} AND GND.

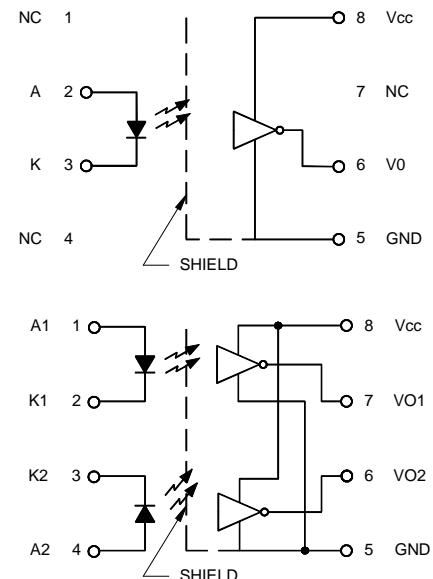
Schematic Diagrams

09/22/03

ELECTRICAL CHARACTERISTICS $T_a = -55^\circ\text{C}$ to at 125°C unless otherwise specified.

PARAMETER	SYMBOL	MIN	TYP	MAX	UNITS	TEST CONDITIONS	NOTE
High Level Output Current	I_{OH}		5	250	μA	$V_{CC} = 5.5\text{V}$, $V_O = 5.5\text{V}$, $I_F = 250\mu\text{A}$	1
Low Level Output Voltage	V_{OL}		0.5	0.6	V	$V_{CC} = 5.5\text{V}$, $I_F = 10\text{mA}$ I_{OL} (Sinking) = 10mA	1,3
High Level Supply Current	I_{CCH}		9	14	mA	$V_{CC} = 5.5\text{V}$, $I_F = 0$ (Both Channels)	
Dual Channel			18	28			
Low Level Supply Current	I_{CCL}		13	18	mA	$V_{CC} = 5.5\text{V}$, $I_F = 20\text{mA}$ (Both Channels)	
Dual Channel			26	36			
Input Forward Voltage	V_F		1.5	1.75	V	$I_F = 20\text{mA}$	1
Input Reverse Breakdown Voltage	BV_R	5			V	$I_R = 10\mu\text{A}$	
Input-Output Insulation Leakage Current	I_{I-O}			1.0	μA	$V_{I-O} = 1500\text{Vdc}$, Relative Humidity = 45% $t_a = 25^\circ\text{C}$, $t = 5\text{s}$	2
Propagation Delay Time To High Output Level	t_{PLH}		45	100	ns	$R_L = 510\Omega$, $C_L = 50\text{pF}$, $I_F = 13\text{mA}$, $t_a = 25^\circ\text{C}$	3,4
Propagation Delay Time To Low Output Level	t_{PHL}		55	100	ns	$R_L = 510\Omega$, $C_L = 50\text{pF}$, $I_F = 13\text{mA}$, $t_a = 25^\circ\text{C}$	3,5

TYPICAL CHARACTERISTICS $T_A = 25^\circ\text{C}$, $V_{CC} = 5\text{V}$ EACH CHANNEL

PARAMETER	SYMBOL	MIN	TYP	MAX	UNITS	TEST CONDITIONS	NOTE
Input Capacitance	C_{IN}		60		pF	$V_F = 0$, $f = \text{MHz}$	1
Input Diode Temperature Coefficient	$\Delta V_F / \Delta T_A$		-1.9		$\text{mV}/^\circ\text{C}$	$I_F = 20\text{mA}$	1
Resistance (Input-Output)	R_{I-O}		10^{12}		Ω	$V_{I-O} = 500\text{V}$	2
Capacitance (Input-Output)	C_{I-O}		5		pF	$f = 1\text{MHz}$	2
Output Rise-Fall Time (10-90%)	t_r , t_f		35		ns	$R_L = 510\Omega$, $C_L = 50\text{pF}$, $I_F = 13\text{mA}$	
Common Mode Transient Immunity at High Output Level	CM_H	1000	10000		$\text{V}/\mu\text{s}$	$V_{CM} = 10\text{V}$ (peak), V_O (min) = 2V, $V_{CC} = 5\text{V}$, $R_L = 510\Omega$, $I_F = 0\text{mA}$	6
Common Mode Transient Immunity at Low Output Level	CM_L	1000	10000		$\text{V}/\mu\text{s}$	$V_{CM} = 10\text{V}$ (peak), V_O (max) = 0.8V, $V_{CC} = 5\text{V}$, $R_L = 510\Omega$, $I_F = 10\text{mA}$	7

NOTES:

- Each channel
- Measured between input pins shorted together and output pins shorted together.
- It is essential that a bypass capacitor (.01 to 0.1 μF ceramic) be connected from pin 5 to pin 8.
- The t_{pLH} propagation delay is measured from the 6.5mA point on the trailing edge of the input pulse to the 1.5V point on the trailing edge of the output pulse.
- The t_{pHL} propagation delay is measured from the 6.5mA point on the leading edge of the input pulse to the 1.5V point on the leading edge of the output pulse.
- CM_H is the max. tolerable common mode transient to assure that the output will remain in a high logic state (i.e. $V_O > 2.0\text{V}$).
- CM_L is the max. tolerable common mode transient to assure that the output will remain in a low logic state (i.e. $V_O < 0.8\text{V}$).

RECOMMENDED OPERATING CONDITIONS:

PARAMETER	SYMBOL	MIN	MAX	UNITS
Input Current, Low Level Each Channel	I_{FL}	0	250	μA
Input Current, High Level Each Channel	I_{FH}	10	20	mA
Supply Voltage	V_C	4.5	5.5	V
Fan Out (TTL Load) Each Channel	N		6	
Operating Temperature	T_A	-55	125	$^\circ\text{C}$

SELECTION GUIDE

PART NUMBER	PART DESCRIPTION
66056-011	Single Channel, Commercial
66056-012	Dual Channel, Commercial
66056-001	Single Channel, military temperature (-55° to +125°C)
66056-002	Dual Channel, military temperature (-55° to +125°C)
66056-101	Single Channel, Screened
66056-102	Dual Channel, Screened
66056-103	DSCC Dwg 8102802PX Dual channel
66056-105	Single channel, 5962-90855 01HPX