

1300nm Fast Ethernet Transceiver in 1 x 9 ST Duplex Package



OPF5112

Technical Data

Features

- 1310nm LED
- Data Rate: 155Mbps, NRZ
- Single +3.3V Power Supply
- PECL Differential Electrical Interface
- Industry Standard 1X 9 Form Factor
- Duplex ST Connector
- Compliance with:
 - 100Base-FX of IEEE802.3u Standard
 - FDDI PMD Standard
- Eye Safety:
 - Designed to meet Laser Class 1 Compliance with EN60825-1

Applications

- Fast Ethernet
- FDDI
- ATM
- SONET
- Multimode fiber links
- Optical-Electrical Interface Conversion

Description

The OPF5112 from Optek is a high performance, cost effective module for serial optical data communications applications specified for 100 Mb/s operation. This transceiver operates with +3.3V power supply and is housed in a plastic package with an industry standard 1 x 9 form factor.

The OPF5112 is a duplex ST transceiver designed for use in Fast Ethernet 100 Base-FX interface. The characterization is performed in accordance FDDI PMD Standard. Likewise, the Fast Ethernet Alliance defines the Physical Layer for 100 Base-FX for Fast Ethernet to be the FDDI PMD Standard.

OPF5112 consists of a transmitter optical sub-assembly, a receiver optical subassembly and an electrical sub-assembly. All are housed in a plastic package and the combination produces a component of high performance and reliability.

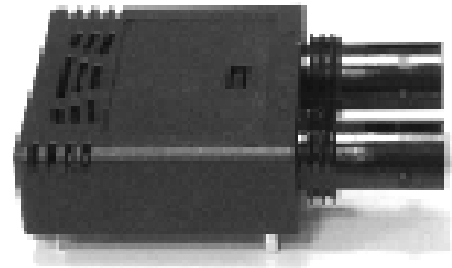

Transmitter

The transmitter section is a 1300nm LED and a driver circuit which converts the differential, PECL digital input signals into an proportional LED drive current. Because the 1300nm wavelength takes advantage of the lower dispersion and attenuation region of glass optical fiber, this transceiver is capable of link distances of 2km at the maximum data rate.

Receiver

The receiver optical sub-assembly consists of a InGaAs PIN photodiode and transimpedance amplifier in an integrated package to optimize performance. The resulting analog output is coupled to a post-amplifier for signal conditioning and conversion to differential, PECL high-speed outputs.

OPF5112 Technical Data



Regulatory Compliance

The OPF5112, and other products from Optek, are designed to comply with regulations governing equipment used in information technology equipment. The goal is for seamless integration of these products into system designs with the confidence that the requirements set forth by the certifying body will be met. For more information, please contact an Optek sales representative or applications engineer.

Electromagnetic Interference (EMI)

EMI compliance is governed by different organizations throughout the world:

- The FCC in the United States
- CENELEC EN55022 in Europe
- VCCI in Japan

The OPF5112 has been design to comply with FCC standards and meet the Class B limits specified therein.

Block Diagram

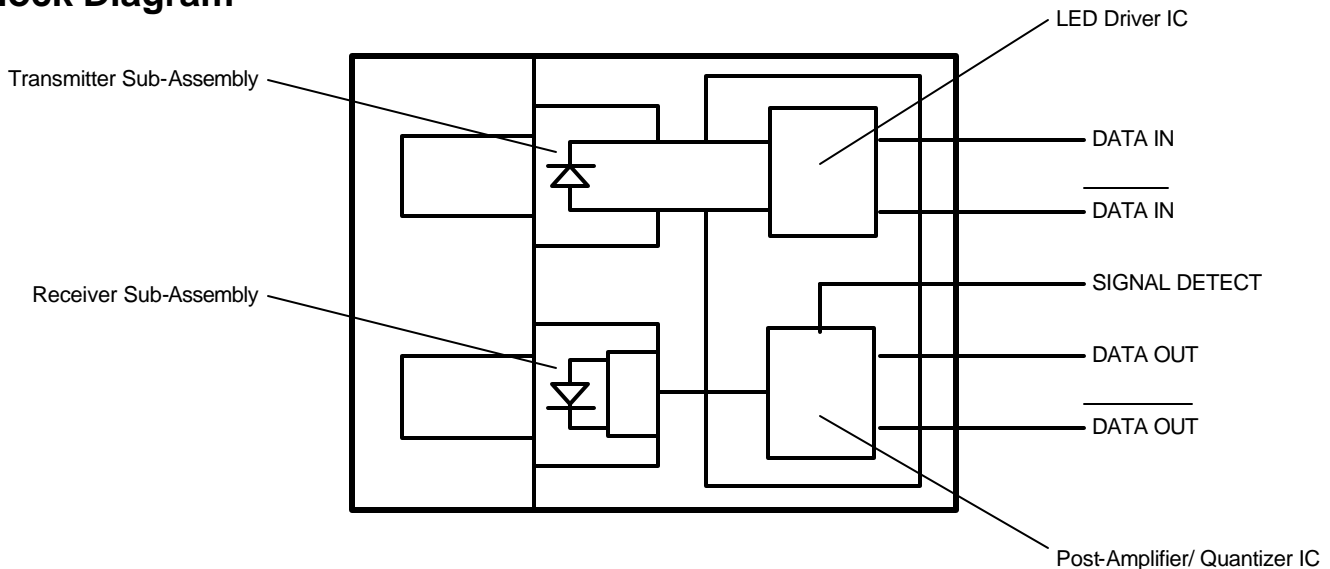

Immunity

Some locations that data communications equipment is located have high levels of radio-frequency electromagnetic fields. The OPF5112 exhibits excellent immunity to these fields.

Eye Safety

All Optek transceivers emit invisible radiation from their optical connector ports. As such, precautions should be taken when using these devices. Optek transceiver products are designed to meet Class 1 eye safety guidelines and comply with EN60825-1.

Electrostatic Discharge

The OPF5112 is subject to damage from ESD. Normal ESD handling practices should be observed when handling this device. Grounded wrist straps, work stations and floor mats are advised.

OPF5112 Technical Data



Transceiver Pin Out Diagram

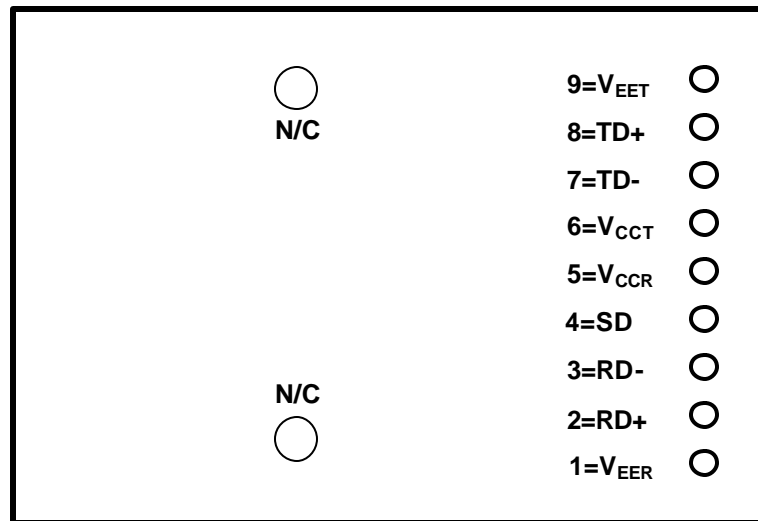

Transceiver Pin Out Table

Pin	Symbol	Functional Description
Mounting Posts		The mounting posts are provided for transceiver mechanical attachment to the circuit board. They should not be connected to the circuit ground but can be connected to the chassis ground.
1	V _{EER}	Receiver Signal Ground
2	RD+	Receiver Data Non-inverted Differential Output
3	RD-	Receiver Data Inverted Differential Output
4	SD	Signal Detect is a PECL output. A high level indicates a received optical signal
5	V _{CCR}	+3.3 V Receiver Power Supply
6	V _{CCT}	+3.3 V Transmitter Power Supply
7	TD-	Transmitter Data Inverted Differential Input
8	TD+	Transmitter Data Non-inverted Differential Input
9	V _{EET}	Transmitter Signal Ground

OPF5112 Technical Data



Absolute Maximum Ratings

Parameter	Symbol	Min	Typ	Max	Units	Test Conditions
Storage Temperature	T_S	-40		85	°C	
Soldering Temperature	T_{SOLD}			260	V	10 Seconds
Supply Voltage	V_{CC}	-0.5		3.6	V	
Input Voltage	V_I	-0.5		V_{CC}	V	

Recommended Operating Conditions

Parameter	Symbol	Min	Typ	Max	Units	Test Conditions
Ambient Operating Temperature	T_A	0		70	°C	
Supply Voltage	V_{CC}	3.135		3.465	V	
High Level Input Voltage	$V_{IH} - V_{CC}$	-1.165		-0.880	V	
Low Level Input Voltage	$V_{IL} - V_{CC}$	-1.810		-1.620	V	

Transmitter Electrical Characteristics

($T_A = 0$ to 70 °C, $V_{CC} = 3.135$ to 3.465 V)

Parameter	Symbol	Min	Typ	Max	Units	Test Conditions
Supply Current	I_{CC}			165	mA	
Power Dissipation	P_D			870	mW	
Data Input Current—High	I_{IH}	-350			μA	Note 1
Data Input Current—Low	I_{IL}			350	μA	Note 1

Receiver Electrical Characteristics

($T_A = 0$ to 70 °C, $V_{CC} = 3.135$ to 3.465 V)

Parameter	Symbol	Min	Typ	Max	Units	Test Conditions
Supply Current	I_{CC}			95	mA	
Power Dissipation	P_D			500	mW	
Receiver Data Output Voltage – Low	$V_{OL} - V_{CC}$	-1.810		-1.620	V	Note 2
Receiver Data Output Voltage – High	$V_{OH} - V_{CC}$	-1.025		-0.880	V	Note 2
Signal Detect Output Voltage - Low	$V_{OL} - V_{CC}$	-1.810		-1.620	V	Note 2
Signal Detect Output Voltage - High	$V_{OH} - V_{CC}$	-1.025		-0.880	V	Note 2

OPF5112 Technical Data



Transmitter Electrical Characteristics

($T_A = 0$ to 70 °C, $V_{CC} = 3.135$ to 3.465 V)

Parameter	Symbol	Min	Typ	Max	Units	Test Conditions
Coupled Optical Power	P_O	-19		-14	dBm	Note 3
Optical Extinction Ratio	ER			10	dB	Note 4,5
Center Wavelength	λ_c	1270		1360	nm	
Spectral Width (FWHM)	??			170	nm	
Optical Rise Time	t_r	0.6		3.0	ns	Note 4
Optical Fall Time	t_f	0.6		3.0	ns	Note 4
Duty Cycle Distortion— Transmitter						
Total Jitter	t_{RJ}			0.69	ns	Note 6

Receiver Electrical Characteristics

($T_A = 0$ to 70 °C, $V_{CC} = 3.135$ to 3.465 V)

Parameter	Symbol	Min	Typ	Max	Units	Test Conditions
Maximum Input Optical Power	P_{MAX}	-14	-11		dBm	Note 6
Receiver Sensitivity	P_{MIN}		-34	-32	dBm	Note 6
Operating Wavelength	?	1100		1600	nm	
Signal Detect—Asserted	P_A			-33	dBm	
Signal Detect—Deasserted	P_D	-45			dBm	Note 7
Signal Detect—Hysteresis	$P_A - P_D$	1.5			dB	Note 8
Random Jitter—Receiver Contribution	RJ			2.14	ns	

Notes:

1. Compatible with 10K , 10KH , 100K ECL and PECL output signals.
2. These outputs are compatible with 10K , 10KH , 100K ECL and PECL inputs.
3. Measured average power coupled into 62.5/125 μ m, 0.275 NA graded index multimode fiber
4. The input data pattern is a 12.5MHz square wave pattern.
5. Extinction Ratio = $10 \cdot \text{LOG}_{10}(\text{PH} / \text{PL})$
6. Measured with $2^{23}-1$ PRBS at $\text{BER} < 1 \times 10^{-10}$
7. Measured on transition – low to high
8. Measured on transition – high to low

OPF5112 Technical Data



Mechanical Dimensions

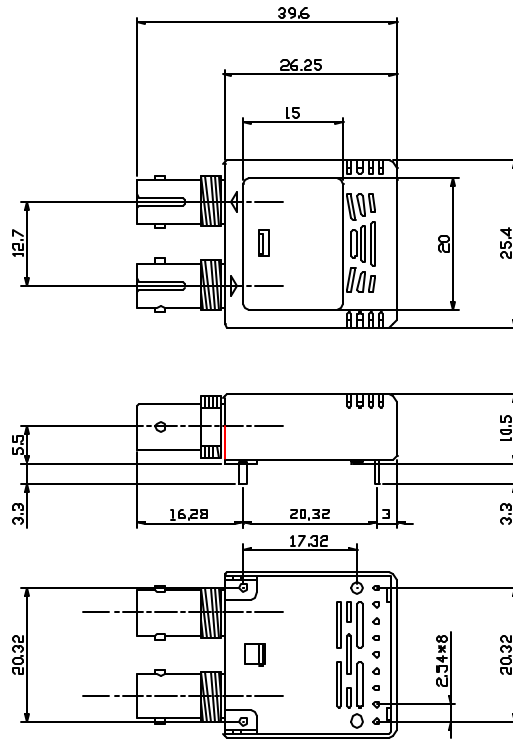

November 2002
OPF5112, Rev. B

Optek reserves the right to make changes at any time in order to improve design and to supply the best product possible.