

XMT5370622

622 Mb/s Logic Interface Laser Transmitter

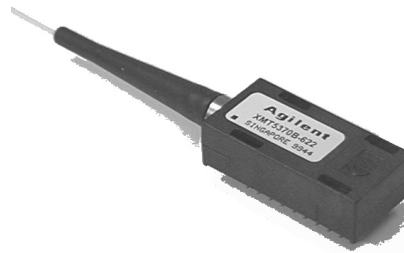

Technical Data



Description

The XMT5370622 is a high performance uncooled optical laser transmitter for CCITT SDH and ANSI SONET applications. It is designed with an ECL/PECL logic interface for 622 Mb/s transmission.

The transmitter incorporates several features which simplify system design. It may be operated with either +5 V or - 5 V power supplies. Standard 10 KH ECL data interface enables direct interface with PECL or ECL logic. The compact transmitter module contains a pigtailed laser, data interface, bias and modulation control circuitry. Thus, no external components or adjustments are necessary. Finally, a laser disable input is provided to shut down the laser for standby or test purposes.

The XMT5370622 provides analog voltage outputs which are proportional to laser bias current and optical power. These may be used with external circuitry to detect end-of-life, or over temperature conditions.

The transmitter is packaged in a 20 pin 0.4" pitch DIP. Contact your local representative for more details.

Features

- SONET/SDH Compliant to STM4 I-4, S-4.1 and OC12 SR, IR.1
- -40°C to +85°C Operation
- Compact 20 Pin Package
- ECL/PECL Logic Interface
- Multisourced Pinout

Applications

- SONET/SDH Systems
- Fiber to the Home
- Data Communications Networks

Connection Diagram

Top View

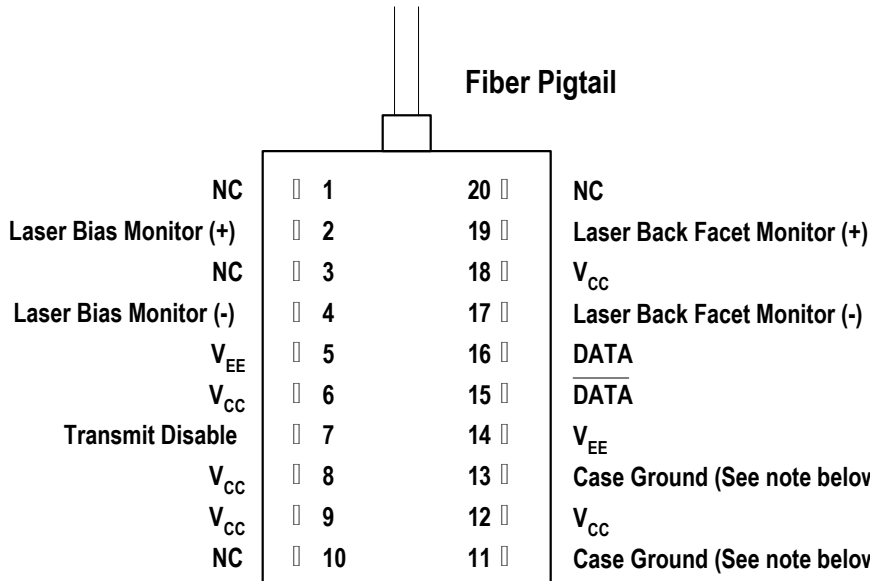

Pin Descriptions

Pins 1, 3, 10, 20, NC:

These pins should not be connected and should be left open circuit on the application PCB.

Pin 2, Laser Bias Monitor (+):

See Figure 1.

Pin 4, Laser Bias Monitor (-):

See Figure 1.

Pins 5, 14, V_{EE}:

These pins are connected to ground in +5 V systems and -5 V in negative supply systems. If connected to -5 V supply, the network shown in Figure 3 should be placed as close as possible to these pins.

Pins 6, 8, 9, 12, 18, V_{CC}:

These pins are connected to +5 V for positive supply systems and ground for -5 V systems. If connected to +5 V supply, the network shown in Figure 3 should be placed as close as possible to these pins.

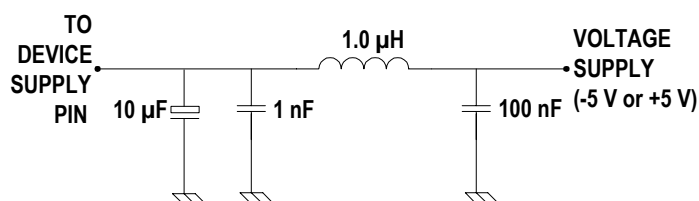

Figure 3. Filter Network

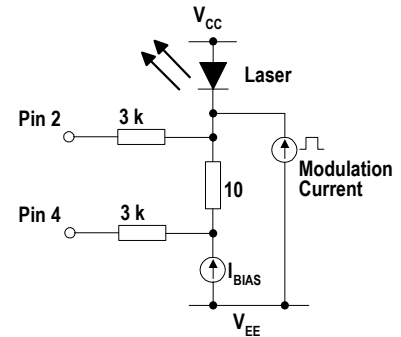

Figure 1. Laser Bias Monitor Circuitry

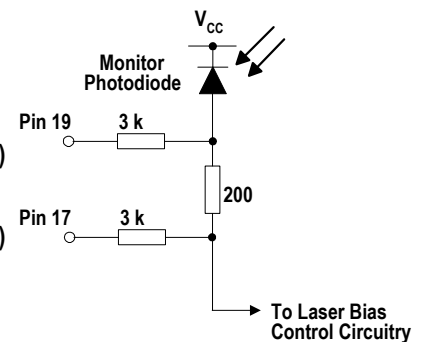

Figure 2. Back Facet Monitor Circuitry

Pin 7, Transmit Disable:

Pin 7 floats to V_{EE} when open circuited, enabling the transmitter. It must be biased within +3 V of V_{CC} to disable.

Pins 11, 13, Ground:

The XMT5370622 case is plastic, therefore these pins are not connected.

Pins 15, 16, DATA, DATA:

These are differential ECL inputs. If open circuited, they will float to V_{BB} ≈ (V_{CC} - 1.3 V).

Pin 17, Laser Back Facet Monitor (-):

See Figure 2.

Pin 19, Laser Back Facet Monitor (+):

See Figure 2.

XMT5370622 Block Diagram

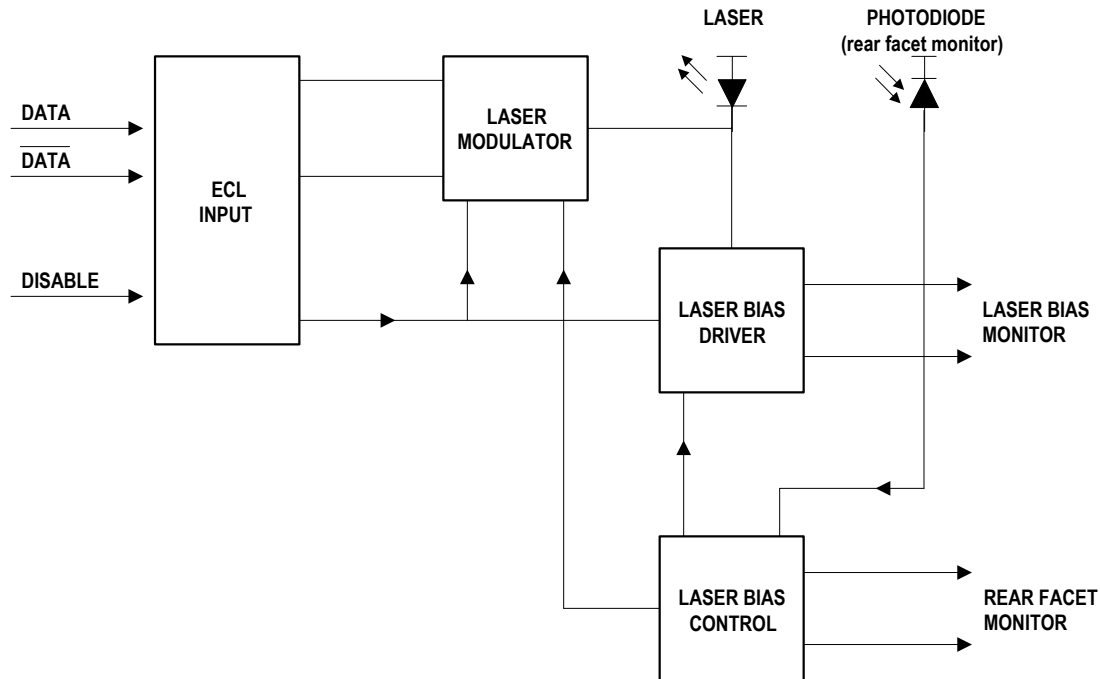

Functional Description

The ECL inputs allow operation from many logic families and both single-ended or differential signals. As both DATA and $\overline{\text{DATA}}$ are internally tied to V_{BB} , for single ended operation the unused input requires no connection or biasing.

The disable function disables the laser bias and modulator. The switching threshold is $V_{CC} - 3.2 \text{ V}$. If this input is not connected the module is enabled. This input may be connected to a CMOS HI or tied to V_{CC} to disable.

The module provides the necessary bias and modulation control to maintain the extinction ratio at better than 8.2 dB and the waveform is compliant with SONET/SDH Eyemask standard G.957.

The laser bias control loop compensates for temperature induced variations in laser performance. The bias current monitor indicates the amount of dc current supplied to the laser. (This is approximately the laser threshold current).

The rear facet monitor is a signal proportional to the laser output power. This can be used as part of a HI/LO light alarm.

In the absence of data the laser will emit a mean optical power within the specified limits. The extinction ratio and duty cycle distortion are specified assuring a 50% duty cycle at the correct data rate.

Performance Specifications

Absolute Maximum Ratings

Stresses in excess of the absolute maximum ratings can cause catastrophic damage to the device. Limits apply to each parameter in isolation, all other parameters having values within the recommended operating conditions. It should not be assumed that limiting values of more than one parameter can be applied to the product at the same time. Exposure to the absolute maximum ratings for extended periods can adversely affect device reliability.

Parameter	Minimum	Nominal	Maximum	Units	Notes
Supply Voltage	-	-	7	V	-
Operating Case Temperature A model	-40	-	+85	°C	-
B model	0	-	+70	°C	-
Storage Temperature	-40	-	+85	°C	-
Fiber Tensile Strength	10	-	-	N/10s	1
Fiber Bend Radius	32	-	-	mm	-
Lead Soldering (Temperature/Time)	-	-	+260/10	°C/Sec	-

Characteristics

Parameter	Minimum	Nominal	Maximum	Units	Notes
Center Wavelength	1270	-	1360	nm	2
Spectral Width (RMS)	-	-	2.5	nm	2
Average Output Power	-15	-10	-8	dBm	3
Extinction Ratio	8.2	-	-	dB	-
Bias Monitor	-	0.1	-	mA/mV	4
Rear Facet Monitor Output	5	-	50	mV	5
Supply Voltage	4.75	5.0	5.5	V	6
Supply Current	-	-	130	mA	7
Tx Disable	$V_{CC} - 3.2$	-	V_{CC}	V	-
Output Waveform	SONET/SDH Eyemask Compliant G.957				

Notes:

1. In a coaxial direction with fiber feed through.
2. Over operating temperature range. A narrower operating temperature range will result in a smaller center wavelength spread. Contact Agilent for details.
3. Other output power options are available. Contact Agilent for details.
4. Common mode signal $V_{EE} + 3.5$ V nominal.
5. Common mode signal $V_{EE} + 1.2$ V nominal.
6. With V_{EE} connected to -5 V, V_{CC} must be at 0 V. With V_{CC} at +5 V, V_{EE} must be at 0 V.
7. End of life at T_{max} .

Drawing Dimensions

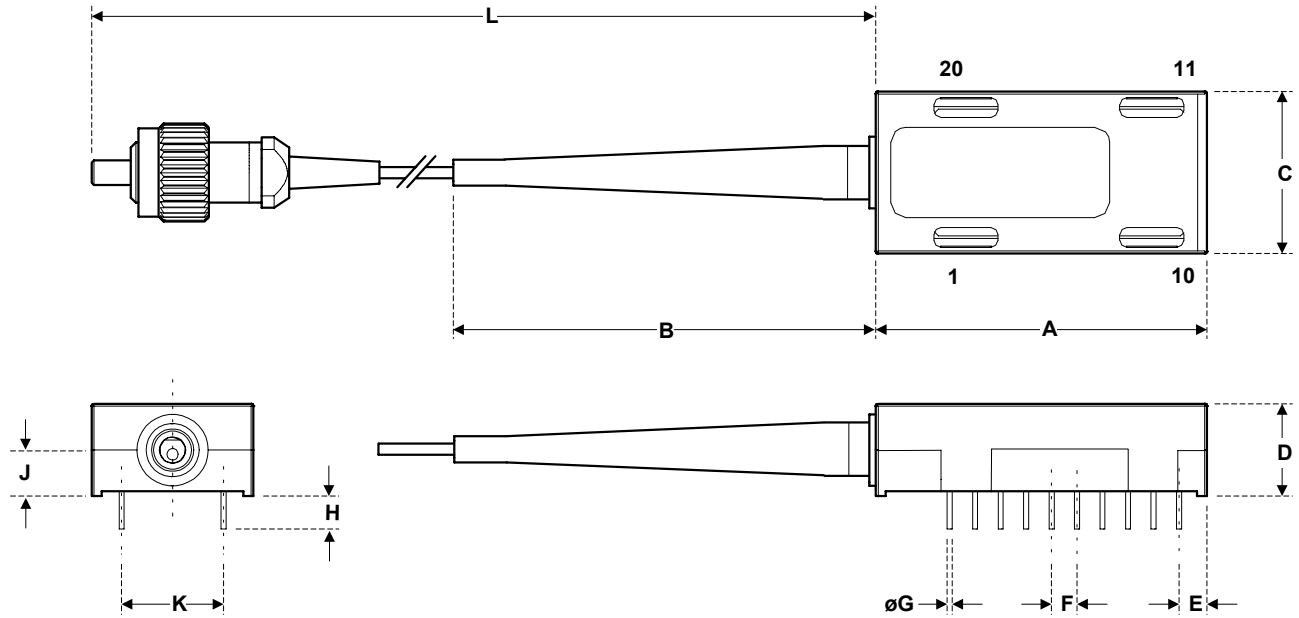

Dimensions	Minimum	Nominal	Maximum
A	32.9	-	33.2
B	39.5	40	40.5
C	16.0	-	16.3
D	-	-	9.27
E	2.6	-	2.95
F	-	2.54	-
ØG	-	0.46	-
H	2.7	-	3.2
J	-	-	4.64
K	-	10.16	-
L	400	-	1220

All dimensions in mm

Ordering Information

XMT5370X622 XX

Connector:
FP = FC/PC Polish
ST = ST[®]
SC = SC

Temperature Option:
A = -40°C to +85°C
B = 0°C to +70°C

Model Name:
XMT5370

Allowable part numbers:

XMT5370A622-FP
XMT5370A622-ST
XMT5370A622-SC
XMT5370B622-FP
XMT5370B622-ST
XMT5370B622-SC

Handling Precautions

1. Normal handling precautions for electrostatic sensitive devices should be taken.
2. Semiconductor lasers can be damaged by overloading or by current surges. Appropriate transient protection should be taken.

ST[®] is a Registered Trademark of AT&T.

Class 1 Laser Product: This product conforms to the applicable requirements of 21 CFR 1040 at the date of manufacture

Date of Manufacture: _____

Avago Technologies Inc., Whitehouse Road, Ipswich,
England

For product information and a complete list of distributors, please go to our web site: www.avagotech.com

Avago, Avago Technologies, and the A logo are trademarks of Avago Technologies, Limited in the United States and other countries. Data subject to change. Copyright © 2007 Avago Technologies Limited. All rights reserved.
5966-0461E - April 5, 2007

AVAGO
TECHNOLOGIES