

# 5 MBd Fiber Optic Receiver Type OPF522

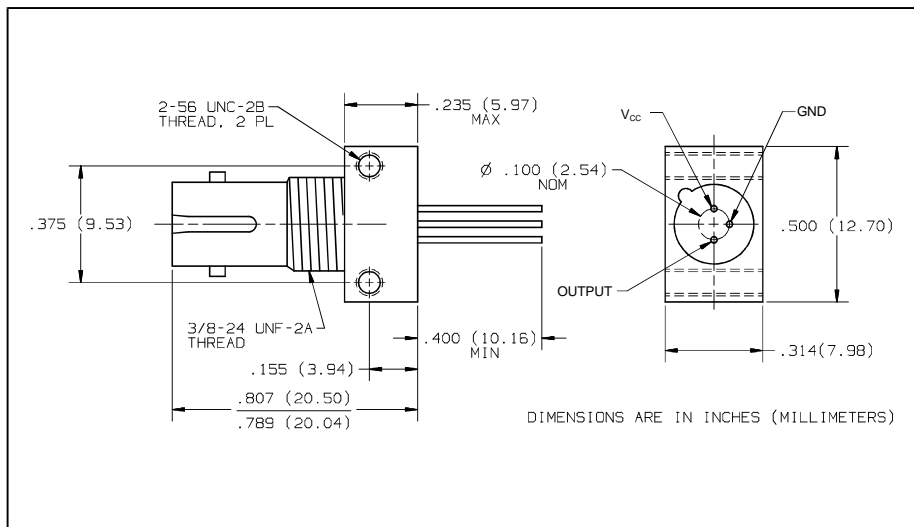
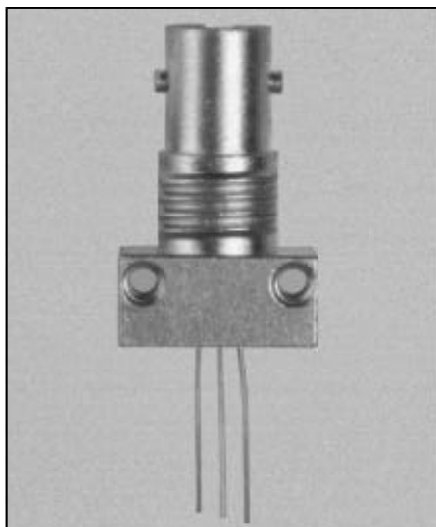

## Features

- Component pre-mounted and ready to use
- Pre-tested with fiber to assure performance
- Popular style receptacle
- Optimized for fiber optic applications using 50 to 200 micron fiber

## Description

The OPF522 contains a monolithic photo-IC comprised of a photodetector and DC amplifier driving an open collector output Schottky transistor. The output makes the OPF522 compatible with TTL and CMOS logic.

The receiver is designed to operate from a single +5V supply. It is essential that a bypass capacitor be connected from V<sub>CC</sub> to Common of the receiver.

## Absolute Maximum Ratings (T<sub>A</sub> = 25° C unless otherwise noted)

Storage Temperature	.....	-55° C to +115° C
Operating Temperature	.....	-40° C to +85° C
Lead Soldering Temperature (for 10 sec.)	.....	260° C
Supply Voltage	.....	-0.5 to 7.0 V
Output Current	.....	25 mA
Output Voltage	.....	-0.5 to 18.0 V
Open Collector Power Dissipation	.....	40 mW
Fan Out (TTL)	.....	5 <sup>(1)</sup>

This component is susceptible to damage from electrostatic discharge (ESD). Normal static precautions should be taken in handling and assembly of this component to prevent ESD damage or degradation.

# Types OPF522

Electrical Characteristics ( $T_A = 25^\circ\text{C}$  unless otherwise noted)

$4.75 \leq V_{CC} \leq 5.25$ , Fiber Sizes  $\leq 100$  Microns, N.A.  $\leq 0.35$ , BER  $\leq 10^{-9}$

Symbol	Parameter	Min	Typ	Max	Units	Test Conditions
$I_{OH}$	High Level Output Current		5	250	$\mu\text{A}$	$V_O = 18\text{ V}$ , $P_R < -40\text{ dBm}$
$V_{OL}$	Low Level Output Voltage		0.4	0.5	V	$I_O = 8\text{ mA}$ , $P_R > -24\text{ dBm}$
$I_{CCH}$	High Level Supply Current		3.5	6.3	mA	$V_{CC} = 5.25\text{ V}$ , $P_R < -40\text{ dBm}$
$I_{CCL}$	Low Level supply Current		6.2	10	mA	$V_{CC} = 5.25\text{ V}$ , $P_R > -24\text{ dBm}$
$P_{RH}$	Peak Input Power Level Logic HIGH			-40	dBm	$\lambda_p = 840\text{ nm}^{(2)}$
				0.1	$\mu\text{W}$	
$P_{RL}$	Peak Input Power Level Logic LOW	-25.4		-9.2	dBm	$\lambda_p = 840\text{ nm}$ , $I_{OL} = 8\text{ mA}^{(2)}$
		2.9		120	$\mu\text{W}$	
		-24		-10	dBm	$-40^\circ\text{C} \leq T_A \leq +85^\circ\text{C}$
		4.0		100	$\mu\text{W}$	
$t_{PLHR}$	Propagation Delay LOW to HIGH		65		ns	$P_R = -21\text{ dBm}$ , Data Rate = 5 MBd
$t_{PHLR}$	Propagation Delay HIGH to LOW		49		ns	

**Notes:**

(1) 8 mA load (5 x 1.6 mA),  $R_L = 560\ \Omega$ .

(2) Measured at the end of 100/140  $\mu\text{m}$  fiber cable with a large area detector.

# Types OPF522