

# 5MBd Fiber Optic Receiver Types OPF2412, OPF2412T

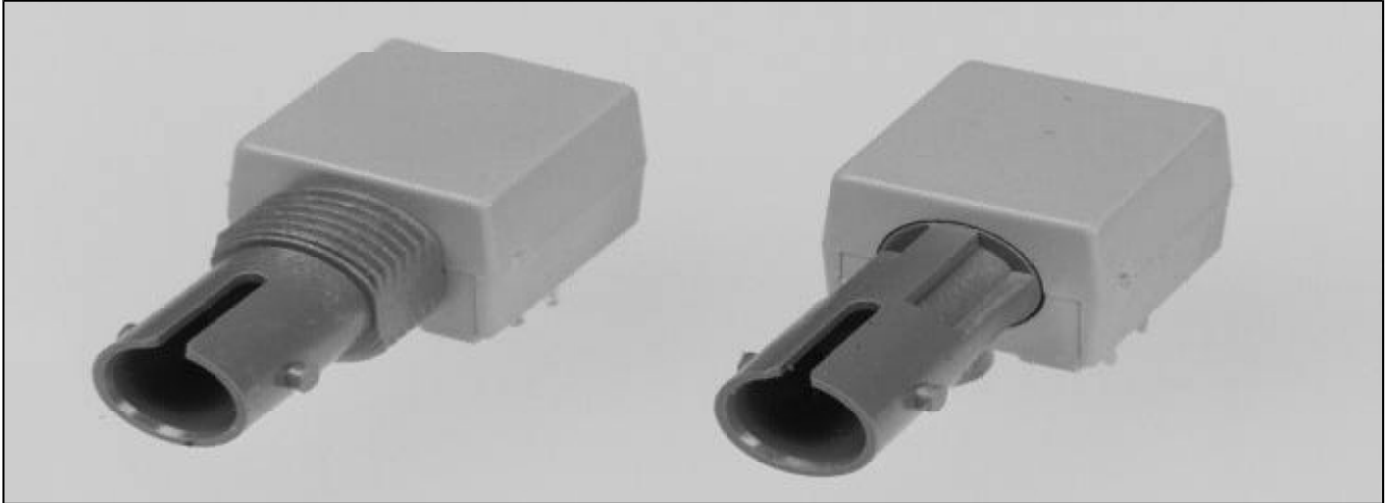

## Features

- Low cost
- CMOS and TTL compatible
- No mounting hardware required
- SMA and ST\* style ports
- Wave Solderable
- Wide temperature range

## Description

The OPF2412 is a low cost digital output fiber optic receiver. The lensed optical system keeps the receiver response consistent for all fiber sizes which makes it ideal for use on fibers as small as 50/125 $\mu$ m.

The OPF2412 contains a monolithic photo-IC comprised of a photodetector and DC amplifier driving an open collector output Schottky transistor. The output makes the OPF2412 compatible with TTL and CMOS logic.

The receiver is designed to operate from a single +5 V supply. A bypass capacitor (0.1  $\mu$ F ceramic) should be connected from Pin 2 (V<sub>CC</sub>) to Pin 3 (Common) of the receiver.

\*ST is a registered trademark of AT&T.

## Absolute Maximum Ratings (T<sub>A</sub> = 25° C unless otherwise noted)

Storage Temperature . . . . .	-55° C to +85° C
Operating Temperature . . . . .	-55° C to +85° C
Lead Soldering Temperature (for 10 sec.) . . . . .	260° C
Supply Voltage . . . . .	-0.5 V to 7.0 V
Output Current . . . . .	25 mA
Output Voltage . . . . .	-0.5 V to 18.0 V
Open Collector Power Dissipation . . . . .	40 mW
Fan Out (TTL) . . . . .	5 <sup>(1)</sup>

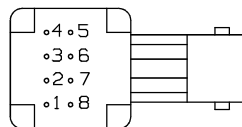
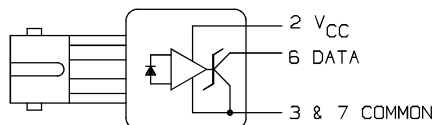

**Bottom View**

PIN	FUNCTION
1**	N.C.
2	V <sub>CC</sub> (5V)
3*	Common
4**	N.C.
5**	N.C.
6	Data
7*	Common
8**	N.C.

\* Pins 3 & 7 are electrically connected to header.  
\*\* Pins 1,4,5 & 8 are electrically connected.

**See Mechanical Dimensions page 8-19 for Mechanical Drawings.**  
**“T” suffix = Threaded ST\* package.**

This component is susceptible to damage from electrostatic discharge (ESD). Normal static precautions should be taken in handling and assembly of this component to prevent ESD damage or degradation.

# Types OPF2412 , OPF2412T

Electrical Characteristics ( $T_A = 25^\circ\text{C}$  unless otherwise noted)

$4.75 \leq V_{CC} \leq 5.25$ , Fiber Sizes  $\leq 100$  Microns, N.A.  $\leq 0.35$ , BER  $\leq 10^{-9}$

Symbol	Parameter	Min	Typ	Max	Units	Test Condition
$I_{OH}$	High Level Output Current		5	250	$\mu\text{A}$	$V_O = 18\text{ V}$ , $P_R < -40\text{ dBm}$
$V_{OL}$	Low Level Output Voltage		0.4	0.5	V	$I_O = 8\text{ mA}$ , $P_R > -24\text{ dBm}$
$I_{CCH}$	High Level Supply Current		3.5	6.3	mA	$V_{CC} = 5.25\text{ V}$ , $P_R < -40\text{ dBm}$
$I_{CCL}$	Low Level supply Current		6.2	10	mA	$V_{CC} = 5.25\text{ V}$ , $P_R > -24\text{ dBm}$
$P_{RH}$	Peak Input Power Level Logic HIGH			-40	dBm	$\lambda_p = 840\text{ nm}^{(2)}$
				0.1	$\mu\text{W}$	
$P_{RL}$	Peak Input Power Level Logic LOW	-25.4		-9.2	dBm	$\lambda_p = 840\text{ nm}$ , $I_{OL} = 8\text{ mA}^{(2)}$
		2.9		120	$\mu\text{W}$	
		-24		-10	dBm	$-40^\circ\text{C} \leq T_A \leq +85^\circ\text{C}$
		4.0		100	$\mu\text{W}$	
$t_{PLHR}$	Propagation Delay LOW to HIGH		65		ns	$P_R = -21\text{ dBm}$ , Data Rate = 5 MBd
$t_{PHLR}$	Propagation Delay HIGH to LOW		49		ns	

**Notes:**

- (1) 8 mA load (5 x 1.6 mA),  $R_L = 560\ \Omega$ .
- (2) Measured at the end of 100/140  $\mu\text{m}$  fiber cable with a large area detector.

## Application Circuit

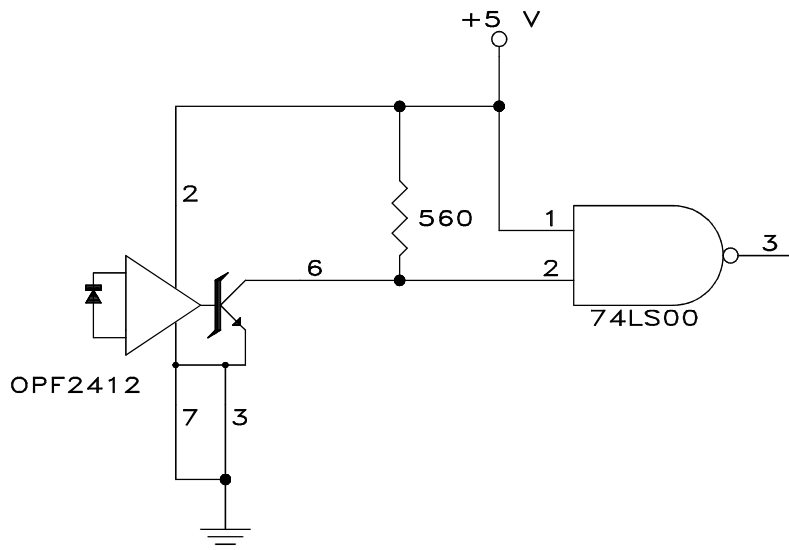

FIBER OPTIC COMPONENTS

# Types OPF2412 , OPF2412T