

# LMH6533

## Four –Channel Laser Diode Driver with Dual Output, LVDS Interface and HFM Oscillator

### General Description

The LMH™ 6533 is a laser diode driver for use in combination DVD/CD recordable and rewritable systems. The part contains two high-current outputs for reading and writing the DVD (650 nm) and CD (780 nm) lasers. Functionality includes read, write and erase through four separate switched current channels. The channel currents are summed together at the selected output to generate multilevel waveforms for reading, writing and erasing of optical discs. The LVDS interface delivers DVD write speeds of 12x and higher while minimizing noise and crosstalk. The LMH6533 is optimized for both speed and power consumption to meet the demands of next generation systems. The part features a 150 mA read channel plus one 300 mA and two 150 mA write channels, which can be summed to allow a total output current of 500 mA or greater. The channel currents are set through four independent current inputs.

The part is manufactured in National Semiconductor's VIP10™ process, which features bonded wafer technology and trench isolation for very high switching speeds at low power levels. An on-board High-Frequency Modulator (HFM) oscillator helps reduce low-frequency noise of the laser and is enabled with the ENOSC pin. The fully differential oscillator circuit minimizes supply line noise, easing FCC approval of the overall system. The SELB pin (active HIGH) selects the output channel and oscillator settings. External resistors determine oscillator frequency and amplitude for each setting. The write and erase channels can be switched on and off through dedicated LVDS interface pins.

### Features

- Fast switching: Rise and fall times <0.8 ns
- Low voltage differential signaling (LVDS) channels enable interface for the fast switching lines
- Low output current noise:  $<0.5nA/\sqrt{Hz}$
- Dual output: Selectable by SELB pin (active HIGH)
- Four independent current channels
  - Gain of 300, 300 mA write channel
  - Gain of 150, 150 mA low-noise read channel
  - Two gain of 150, 150 mA write channels
  - 500 mA minimum combined output current
- Integrated AC Coupled HFM Oscillator
  - Selectable frequency and amplitude setting by external resistors
  - 200 MHz to 600 MHz frequency range
  - Amplitude to 100 mA peak-to-peak modulation
- Complete shutdown by ENABLE pin
- 5V single-supply operation
- Logic inputs TTL and CMOS compatible
- Space saving Leadless Leadframe Package LLP®-28

### Applications

- Combination DVD/CD recordable and rewritable drives
- DVD camcorders
- DVD video recorders

### Block Diagram

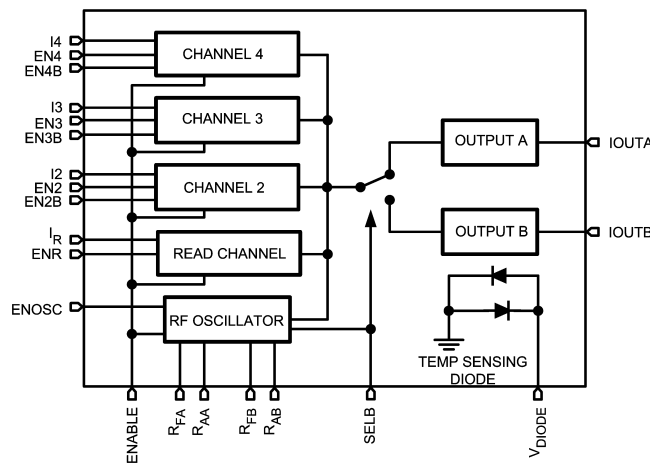

20027701

LMH™ is a trademark of National Semiconductor Corporation.  
 VIP10™ is a trademark of National Semiconductor Corporation.  
 LLP® is a registered trademark of National Semiconductor.

**Absolute Maximum Ratings** (Note 1)

If Military/Aerospace specified devices are required, please contact the National Semiconductor Sales Office/Distributors for availability and specifications.

ESD Tolerance	
Human Body Model	2KV (Note 2)
Machine Model	200V (Note 3)
Supply Voltage ( $V^+ - V^-$ )	5.5V
Differential Input Voltage	$\pm 5.5V$
Output Short Circuit to Ground (Note 4)	Continuous
Input Common Mode Voltage	$V^-$ to $V^+$
Storage Temperature Range	$-65^\circ\text{C}$ to $+150^\circ\text{C}$
Junction Temperature (Note 5)	$+150^\circ\text{C}$

**Operating Ratings** (Note 1)

Supply Voltage ( $V^+ - V^-$ )	$4.5V \leq V_S \leq 5.5V$
Operating Temp. Range ( $T_A$ ) (Note 8)	$-40^\circ\text{C} \leq T_A \leq 85^\circ\text{C}$
Thermal Resistance (Note 5), (Note 8)	LLP Package
$\theta_{JC}$	$3^\circ\text{C/W}$
$\theta_{JA}$ (no heatsink)	$42^\circ\text{C/W}$
$\theta_{JA}$ (with heatsink) see (Note 9)	$30.8^\circ\text{C/W}$
$I_{INR}/3/4$	1.5 mA (max)
$I_{IN2}$	1.0 mA (max)
$R_{FREQ}$	1000 $\Omega$ (min)
$R_{AMP}$	300 $\Omega$
$F_{OSC}$	100-600 MHz
$A_{OSC}$	10-100 mA <sub>PP</sub>

**+5V DC Electrical Characteristics**

Unless otherwise specified, all limits guaranteed for  $T_J = 25^\circ\text{C}$ ,  $R_L = 10\Omega$ . **Boldface** limits apply at the temperature extremes. (Note 8)

Symbol	Parameter	Conditions	Min (Note 7)	Typ (Note 6)	Max (Note 7)	Units
<b>LVDS</b>						
$V_I$	Input Voltage Range	$ V_{GPD}  < 50\text{ mV}$ (Note 7), (Note 9), (Note 11)	825	1550	1575	mV
$V_{IDTH}$	Input Diff. Threshold	$V_{GPD} < 50\text{ mV}$ (Note 7), (Note 9), (Note 11)	-100	0	100	mV
$V_{HYST}$	Input Diff. Hysteresis	$V_{IDTHH} - V_{IDTH1}$ (Note 7), (Note 9), (Note 11)	25	0		mV
$R_{IN}$	Input Diff. Impedance	(Note 7), (Note 9), (Note 11)	80	104	120	$\Omega$
$I_{IN}$	Input Current	Excluding $R_{IN}$ Current $V_{CM} = 1.25V$		5	50	$\mu\text{A}$
<b>Current Channels</b>						
$R_{IN}$	Input Resistance all Channels	$R_{IN}$ to Ground	425	556	675	$\Omega$
$I_{OS}$	Current Offset	All Channels Off (Note 12)	-7.5	4.75	7.5	mA
$A_{IW}$	Current Gain	Channel 2 (Note 13)	270	303	330	A/A
$A_{IR}$	Current Gain	Channels 3,4 and Read (Note 13)	135	152	165	A/A
$I_{LIN-R,3,4}$	Output Current Linearity	$500\ \mu\text{A} < I_{IN} < 1000\ \mu\text{A}$ ; $R_{LOAD} = 10\Omega$ Channels Read, 3 and 4	-3.5	2.5	+3.5	%
$I_{LIN-2}$	Output Current Linearity	$500\ \mu\text{A} < I_{IN} < 1000\ \mu\text{A}$ ; $R_{LOAD} = 10\Omega$ Channels 2	-8	5	+8	%
$I_{OUTW}$	Output Current	Channel 2 (Note 12) @ 1mA Input Current	250	263		mA
$I_{OUTR,3,4}$	Output Current	Channel 3, 4 and Read (Note 12) @ 1 mA Input Current	135	150		mA
$I_{OUTTOTAL}$	Total Output Current	All Channels (Note 14); $R_{LOAD} = 5\Omega$	500			mA
$V_{TLO}$	TTL Low Voltage	ENR, ENOSC Input (H to L)		1.51	0.8	V
$V_{ELO}$	Enable Low Voltage	Enable Input (H to L)		2.41	0.8	V
$V_{THI}$	TTL High Voltage	ENR, ENOSC Inputs (L to H)	2.0	1.54		V
$V_{EHI}$	Enable High Voltage	Enable Input (L to H)	2.8	2.4		V
$I_{SPD}$	Supply Current, Power Down	Enable = Low (Note 12)		0.003	<b>0.5</b>	mA
$I_{Sr1}$	Supply Current, Read Mode, Oscillator Disabled	ENOSC = Low; (Note 12) $I_2 = I_3 = I_4 = I_R = 125\ \mu\text{A}$		98.5	<b>120</b>	mA
$I_{Sr2}$	Supply Current, Read Mode, Oscillator Enabled	ENOSC = High; (Note 12) $I_2 = I_3 = I_4 = I_R = 125\ \mu\text{A}$		98.5	<b>120</b>	mA

**+5V DC Electrical Characteristics** (Continued)

Unless otherwise specified, all limits guaranteed for  $T_J = 25^\circ\text{C}$ ,  $R_L = 10\Omega$ . **Boldface** limits apply at the temperature extremes. (Note 8)

Symbol	Parameter	Conditions	Min (Note 7)	Typ (Note 6)	Max (Note 7)	Units
$I_{\text{SWR}}$	Supply Current, Write Mode	EN2 = EN3 = EN4 = High; (Note 12) $I_2 = I_3 = I_4 = I_R = 125\ \mu\text{A}$		182.5	<b>210</b>	mA
$I_S$	Supply Current	All Channels Disable, No Input Current. SELB = 0; $R_{AA}$ , $R_{AB}$ , $R_{FA}$ , $R_{FB} = \infty$		45		mA

**+5V AC Electrical Characteristics**

Unless otherwise specified, all limits guaranteed for  $T_J = 25^\circ\text{C}$ ,  $R_L = 10\Omega$ . **Boldface** limits apply at the temperature extremes. (Note 8)

Symbol	Parameter	Conditions	Min (Note 7)	Typ (Note 6)	Max (Note 7)	Units
$t_r$	Write Rise Time	$I_{\text{OUT}} = 40\ \text{mA (Read)} + 40\ \text{mA (10% to 90%)}$ $R_{\text{LOAD}} = 5\Omega$		0.50		ns
$t_f$	Write Fall Time	$I_{\text{OUT}} = 40\ \text{mA (Read)} + 40\ \text{mA (90% to 10%)}$ $R_{\text{LOAD}} = 5\Omega$		0.76		ns
$t_r$	Write Rise Time	$I_{\text{OUT}} = 100\ \text{mA (Read)} + 100\ \text{mA (10% to 90%)}$ $R_{\text{LOAD}} = 5\Omega$		0.65		ns
$t_f$	Write Fall Time	$I_{\text{OUT}} = 100\ \text{mA (Read)} + 100\ \text{mA (90% to 10%)}$ $R_{\text{LOAD}} = 5\Omega$		0.75		ns
$t_r$	Write Rise Time	$I_{\text{OUT}} = 150\ \text{mA (Read)} + 150\ \text{mA (10% to 90%)}$ $R_{\text{LOAD}} = 5\Omega$		0.78		ns
$t_f$	Write Fall Time	$I_{\text{OUT}} = 150\ \text{mA (Read)} + 150\ \text{mA (90% to 10%)}$ $R_{\text{LOAD}} = 5\Omega$		0.77		ns
OS	Output Current Overshoot	$I_{\text{OUT}} = 40\ \text{mA (Read)} + 40\ \text{mA}$		16		%
$IN_o$	Output Current Noise	$I_{\text{OUT}} = 40\ \text{mA}$ ; $R_{\text{LOAD}} = 50\Omega$ ; $f = 10\ \text{MHz}$ ; ENOSC = Low		0.47		nA/ $\sqrt{\text{Hz}}$
$t_{\text{ON}}$	$I_{\text{OUT}}$ ON Prop. Delay	Switched on EN2 and EN2B		0.45		ns
$t_{\text{OFF}}$	$I_{\text{OUT}}$ OFF Prop. Delay	Switched on EN2 and EN2B		0.40		ns
$t_{\text{disr}}$	Disable Time, Read Channel	Switch on ENR		1.1		ns
$t_{\text{enr}}$	Enable Time, Read Channel	Switch on ENR		1.1		ns
$t_{\text{dis}}$	Disable Time, (Shutdown)			3		$\mu\text{s}$
$t_{\text{en}}$	Enable Time, (Shutdown)			3		$\mu\text{s}$
$BW_C$	Channel Bandwidth, -3 dB	$I_{\text{OUT}} = 50\ \text{mA}$ , All Channels		2.5		MHz
$f_{\text{OSC}}$	Oscillator Frequency	$R_F = 3\ \text{k}\Omega$ Range 200 MHz to 600 MHz	270	330	390	MHz
$T_{\text{DO}}$	Disable Time Oscillator			5.2		ns
$T_{\text{EO}}$	Enable Time Oscillator			5.4		ns

**Note 1:** "Absolute Maximum Ratings" are those values beyond which the safety of the device cannot be guaranteed. They are not meant to imply that the devices should be operated at these limits. The table of "Electrical Characteristics" specifies conditions of device operation.

**Note 2:** For testing purposes, ESD was applied using 'Human body model'; 1.5 k $\Omega$  in series with 100 pF

**Note 3:** Machine Model, 0 $\Omega$  in series with 200 pF.

**Note 4:** Applies to both single-supply and split-supply operation. Continuous short circuit operation at elevated ambient temperature can result in exceeding the maximum allowed junction temperature of 150 $^\circ\text{C}$

**Note 5:** The maximum power dissipation is a function of  $T_{J(\text{MAX})}$ ,  $\theta_{JA}$ , and  $T_A$ . The maximum allowable power dissipation at any ambient temperature is  $PD = (T_{J(\text{MAX})} - T_A) / \theta_{JA}$ . All numbers apply for packages soldered directly onto a PC board.

**Note 6:** Typical values represent the most likely parametric norm.

**Note 7:** All limits are guaranteed by testing or statistical analysis.

**Note 8:** Electrical Table values apply only for factory testing conditions at the temperature indicated. Factory testing conditions result in very limited self-heating of the device such that  $T_J = T_A$ . There is no guarantee of parametric performance as indicated in the electrical tables under conditions of internal self-heating where  $T_J > T_A$ . See Applications section for information on temperature de-rating of this device.

**Note 9:**  $V_{\text{GPD}}$  = ground potential difference voltage between driver and receiver

**Note 10:** This figure is taken from a thermal modeling result. The test board is a 4 layer FR-4 board measuring 101 mm x 101 mm x 1.6 mm with a 3 x 3 array of thermal vias. The ground plane on the board is 50 mm x 50 mm. Ambient temperature in simulation is 22°C, still air. Power dissipation is 1W.

**Note 11:** Reference IEEE Reduced Range Link (RRL) specifications.

**Note 12:** Positive current corresponds to current flowing into the device.

**Note 13:** Input currents are set to 0.3 mA

**Note 14:** Total input current is 4.4 mA (all 4 channels equal) and output currents are summed together (see typical performance characteristics).

## Connection Diagram

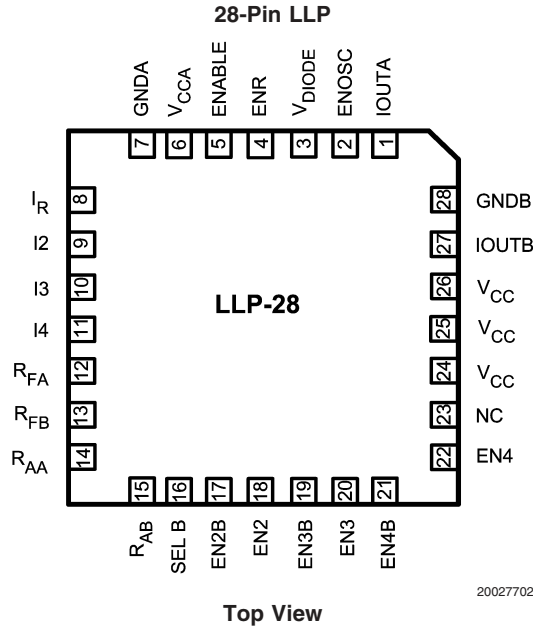

## Ordering Information

Package	Part Number	Package Marking	Transport Media	NSC Drawing
28-Pin LLP	LMH6533SP NOPB	LMH6533SP	1k Units Tape and Reel	SPA28A
	LMH6533SPX NOPB		4.5k Units Tape and Reel	

## Pin Description

Pin #	Description	Remark
1	Laser driver output channel A	
2	Internal Oscillator Enable pin	Oscillator activated if pin is high
3	Temp Sensing Diode	See application note on using this pin
4	Read Channel Enable pin	Read Channel Enabled if pin is high
5	Chip Enable pin	Chip Enabled if pin is high
6	Supply Voltage A	
7	Ground Connection A	
8	Read Channel current setting	
9	Channel 2 current setting	
10	Channel 3 current setting	
11	Channel 4 current setting	
12	Oscillator Frequency setting Channel A	Set by external resistor to ground
13	Oscillator Frequency setting Channel B	Set by external resistor to ground
14	Oscillator Amplitude setting Channel A	Set by external resistor to ground
15	Oscillator Amplitude setting Channel B	Set by external resistor to ground
16	Channel select B	Channel B selected if pin is high
17	LVDS input Channel 2B	Channel 2 active if logical input is low
18	LVDS input Channel 2	Channel 2 active if logical input is high
19	LVDS input Channel 3B	Channel 3 active if logical input is low
20	LVDS input Channel 3	Channel 3 active if logical input is high
21	LVDS input Channel 4B	Channel 4 active if logical input is low
22	LVDS input Channel 4	Channel 4 active if logical input is high
23	NC	
24	Supply Voltage	
25	Supply Voltage	
26	Supply Voltage	
27	Laser driver output channel B	
28	Ground Connection B	

## Truth Tables

### IOUT CONTROL

Enable	ENR	EN2	EN3	EN4	IOUT
0	X	X	X	X	OFF
1	0	0	0	0	OFF
1	1	0	0	0	$A_R * I_{INR}$
1	1	1	0	0	$A_R * I_{INR} + A_2 * I_{IN2}$
1	1	0	1	0	$A_R * I_{INR} + A_3 * I_{IN3}$
1	1	0	0	1	$A_R * I_{INR} + A_4 * I_{IN4}$

### OSCILLATOR CONTROL

Enable	ENOSC	ENR	EN2	EN3	EN4	Oscillator
0	x	x	x	x	x	OFF
1	0	x	x	x	x	OFF
1	1	x	x	x	x	on

# Waveforms

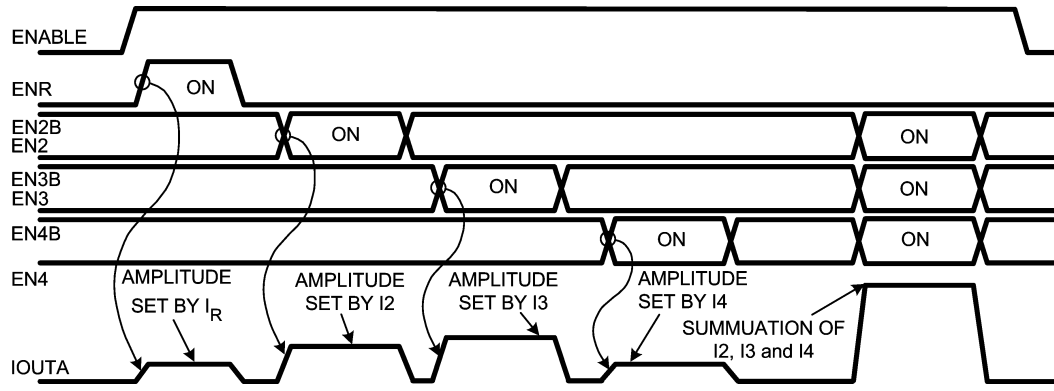

20027703

Functional Timing Diagram

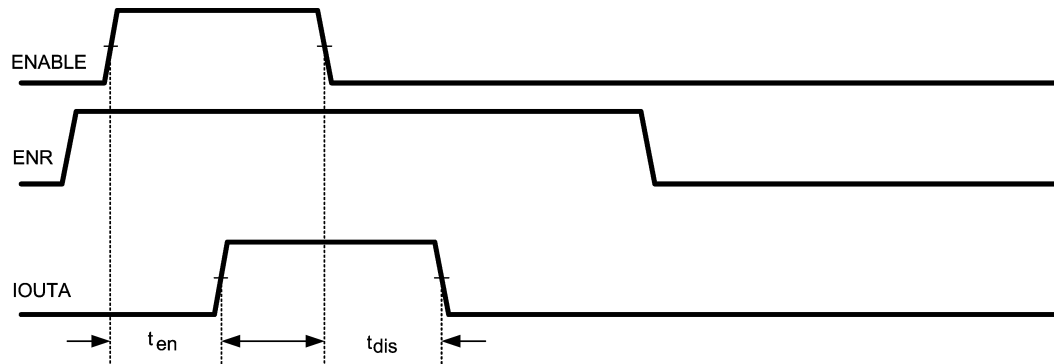

20027704

Enable Timing

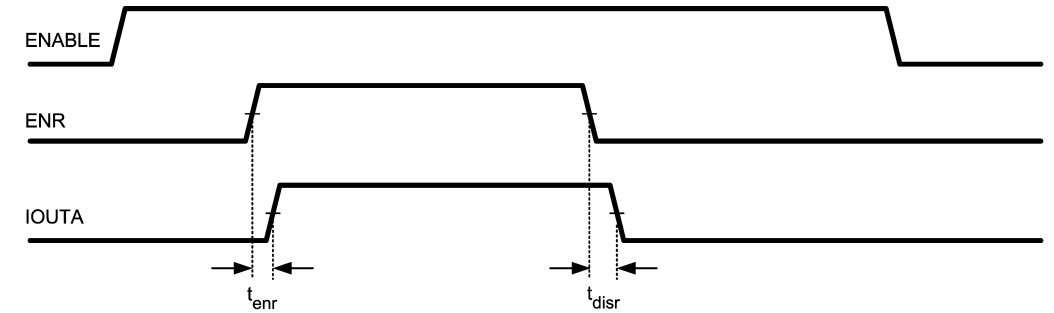

20027705

Read Timing

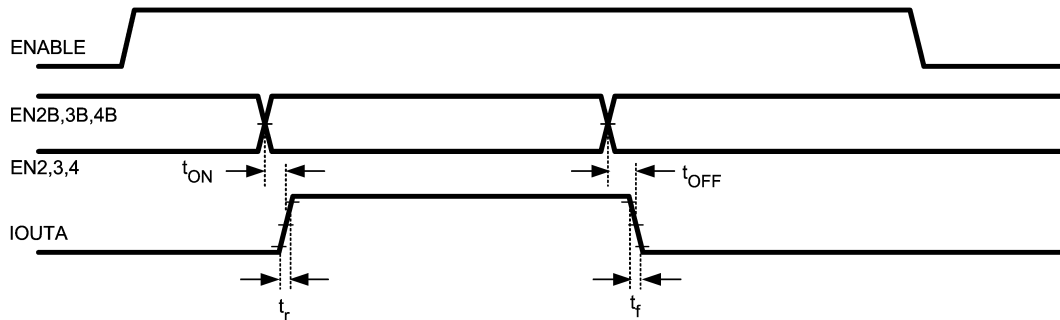

20027706

Write Timing

### Waveforms (Continued)

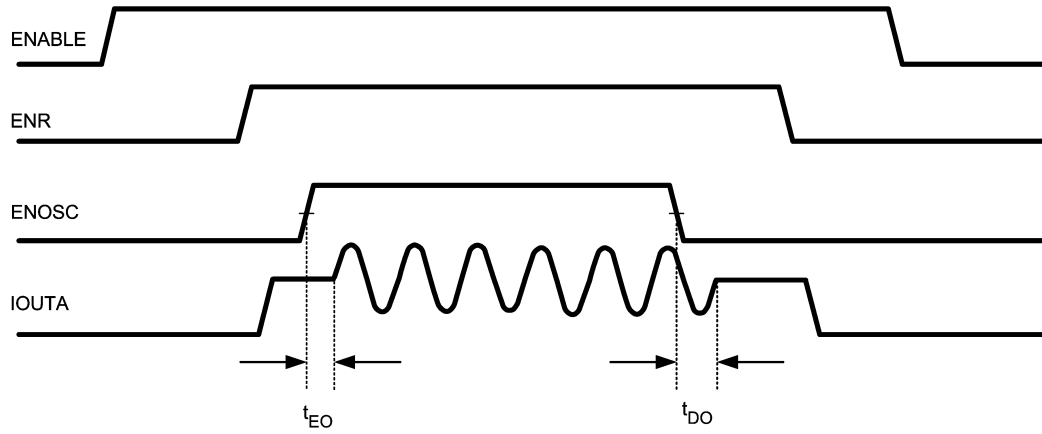

Oscillator Timing

20027707

### Detailed Block Diagram

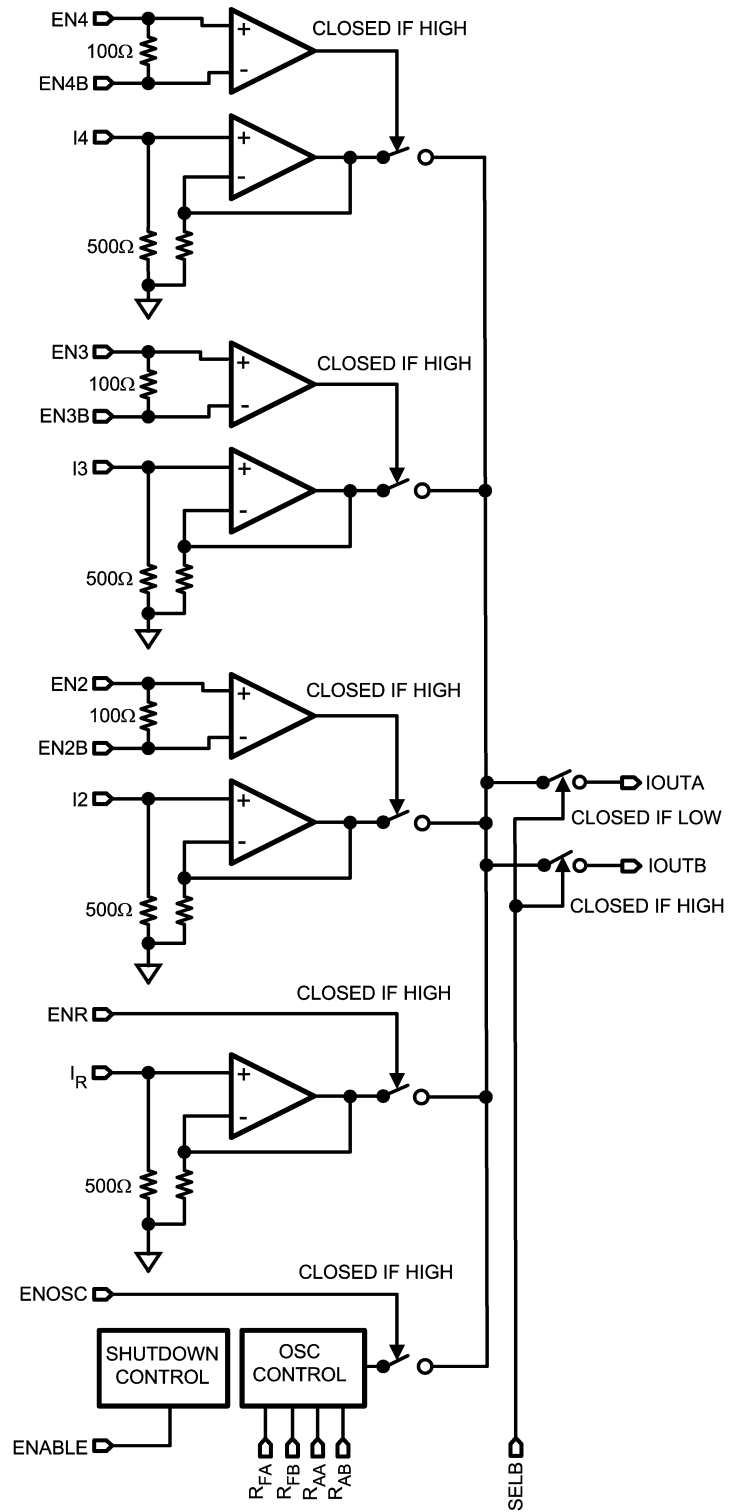

20027708





**Typical Performance Characteristics** At  $T_J = 25^\circ\text{C}$ ;  $V^+ = +5\text{V}$ ;  $V^- = -50\text{V}$ ; Unless otherwise specified.

**Oscillator Amplitude vs.  $R_A$**

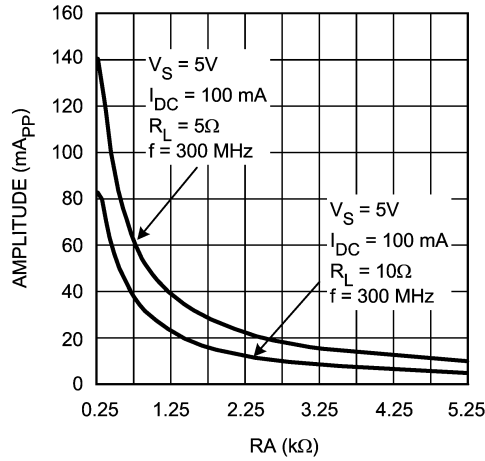

20027710

**Oscillator Frequency vs.  $R_F$**

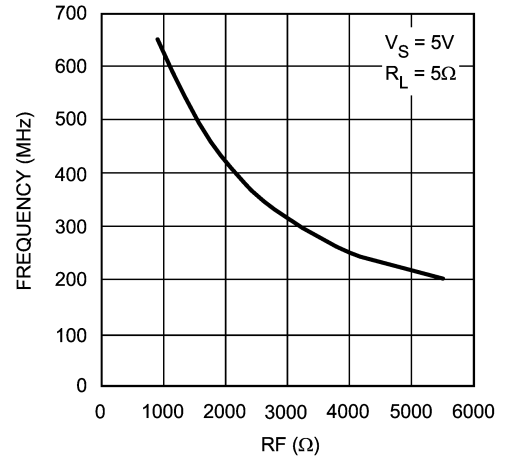

20027711

**Headroom & Output Current vs. Total Input Current**

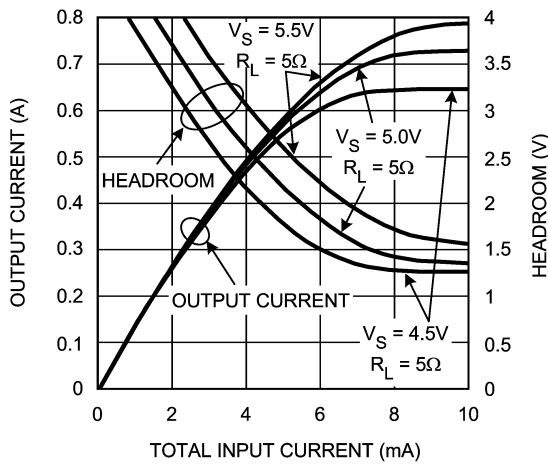

20027719

**Pulse Response**

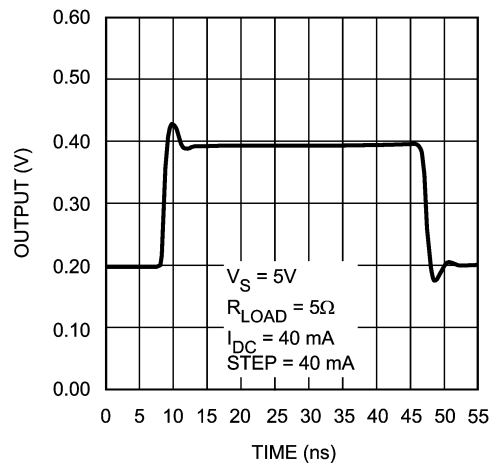

20027720

**Noise vs. Frequency**

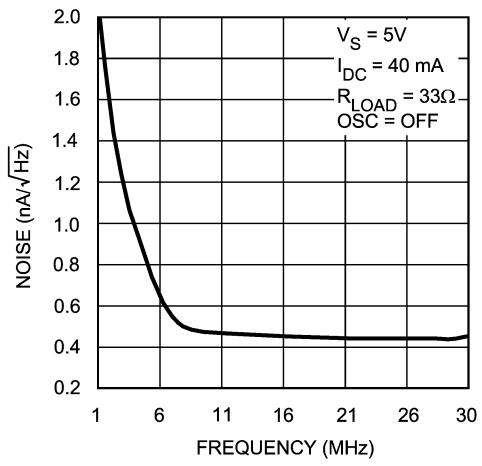

20027721

**Physical Dimensions** inches (millimeters) unless otherwise noted

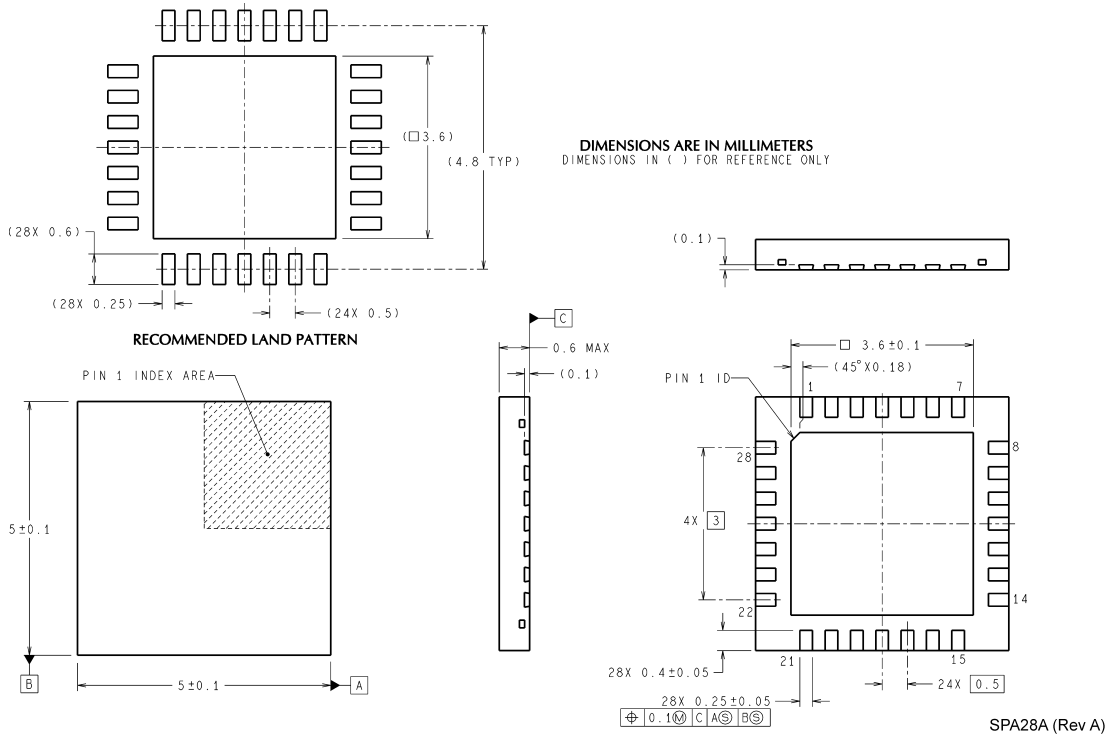

**LIFE SUPPORT POLICY**

NATIONAL'S PRODUCTS ARE NOT AUTHORIZED FOR USE AS CRITICAL COMPONENTS IN LIFE SUPPORT DEVICES OR SYSTEMS WITHOUT THE EXPRESS WRITTEN APPROVAL OF THE PRESIDENT AND GENERAL COUNSEL OF NATIONAL SEMICONDUCTOR CORPORATION. As used herein:

1. Life support devices or systems are devices or systems which, (a) are intended for surgical implant into the body, or (b) support or sustain life, and whose failure to perform when properly used in accordance with instructions for use provided in the labeling, can be reasonably expected to result in a significant injury to the user.
2. A critical component is any component of a life support device or system whose failure to perform can be reasonably expected to cause the failure of the life support device or system, or to affect its safety or effectiveness.

**BANNED SUBSTANCE COMPLIANCE**

National Semiconductor certifies that the products and packing materials meet the provisions of the Customer Products Stewardship Specification (CSP-9-111C2) and the Banned Substances and Materials of Interest Specification (CSP-9-111S2) and contain no "Banned Substances" as defined in CSP-9-111S2.



**National Semiconductor**  
Americas Customer  
Support Center  
Email: new.feedback@nsc.com  
Tel: 1-800-272-9959

**National Semiconductor**  
Europe Customer Support Center  
Fax: +49 (0) 180-530 85 86  
Email: europe.support@nsc.com  
Deutsch Tel: +49 (0) 69 9508 6208  
English Tel: +44 (0) 870 24 0 2171  
Français Tel: +33 (0) 1 41 91 8790

**National Semiconductor**  
Asia Pacific Customer  
Support Center  
Email: ap.support@nsc.com

**National Semiconductor**  
Japan Customer Support Center  
Fax: 81-3-5639-7507  
Email: jpn.feedback@nsc.com  
Tel: 81-3-5639-7560

www.national.com