

## Fast Infrared Transceiver Module (4 Mbit/s), IrDA<sup>®</sup> Serial Interface Compatible, 2.7 V to 5.5 V Supply Voltage Range

### Description

The TFDU6108 is an infrared transceiver module compliant to the latest IrDA standard for fast infrared data communication, supporting IrDA speeds up to 4.0 Mbit/s (FIR), and carrier based remote control modes up to 2 MHz. Integrated within the transceiver module are a PIN photodiode, an infrared emitter (IRED), and a low-power CMOS control IC to provide a total front-end solution in a single package.

These FIR transceivers with an integrated serial interface are compliant with the IrDA "Serial Interface Standard for Transceiver Control". The transceivers are capable of directly interfacing with a wide variety of I/O devices, which perform the modulation/demodulation function. At a minimum, a  $V_{CC}$  bypass capacitor is the only external component required implementing a complete solution. For limiting the transceiver internal power dissipation one additional resistor might be added. The transceiver can be operated with logic I/O voltages as low as 1.5 V.

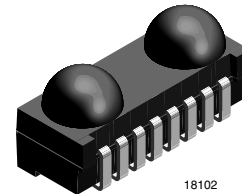

### New Features

- The functionality of the device is similar to the TFDU6102 series. The IrDA compatible serial interface function is replacing the former programming method, guaranteeing a perfect IrDA standardized and compliant programmability. The IRED current is programmable to different levels, no external current limiting resistor is necessary.

### Features

- Compliant to the latest IrDA physical layer specification (Up to 4 Mbit/s) TV Remote Control
- Compliant to the IrDA "Serial Interface Specification for Transceivers"
- For 3.0 V and 5.0 V Applications, fully specified 2.7 V to 5.5 V Operational down to 2.6 V
- Compliant to all logic levels between 1.5 V and 5 V
- Low Power Consumption (typ. 2.0 mA Supply Current)
- Power Shutdown Mode (< 1  $\mu$ A Shutdown Current)
- Surface Mount Package Options
  - Universal (L 9.7 mm  $\times$  W 4.7 mm  $\times$  H 4.0 mm)
  - Side and Top View
- Tri-State-Receiver Output, Weak Pull-up when in Shutdown Mode



- High Efficiency Emitter
- Baby Face (Universal) Package Capable of Surface Mount Soldering to Side and Top View Orientation
- Eye safety class 1 (IEC60825-1, ed. 2001), limited LED on-time, LED current is controlled, no single fault to be considered
- Built - In EMI Protection including GSM bands. EMI Immunity in GSM Bands > 300 V/m verified No External Shielding Necessary
- Few External Components Required
- Pin to Pin Compatible to Legacy Vishay Semiconductor SIR and FIR Infrared Transceivers
- Split power supply, transmitter and receiver can be operated from two power supplies with relaxed requirements saving costs, US Patent No. 6,157,476
- Compliant with IrDA EMI and Background Light Specification
- Lead (Pb)-free device
- Device in accordance to RoHS 2002/95/EC and WEEE 2002/96EC

### Applications

- Notebook Computers, Desktop PCs, Palmtop Computers (Win CE, Palm PC), PDAs
- Printers, Fax Machines, Photocopiers, Screen Projectors
- Telecommunication Products (Cellular Phones, Pagers)
- Internet TV Boxes, Video Conferencing Systems
- External Infrared Adapters (Dongles)
- Medical and Industrial Data Collection Devices

## Parts Table

Part	Description	Qty / Reel
TFDU6108-TR3	Oriented in carrier tape for side view surface mounting	1000 pcs
TFDU6108-TT3	Oriented in carrier tape for top view surface mounting	1000 pcs

## Functional Block Diagram

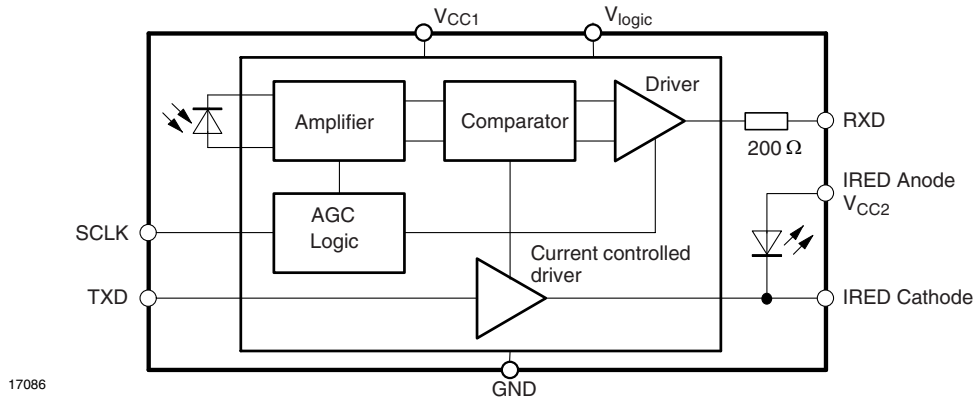

## Pin Description

Pin Number	Function	Description	I/O	Active
1	IRED Anode	Connect IRED anode directly to $V_{CC2}$ . An unregulated separate power supply can be used at this pin. For $V_{CC2} > 4\text{ V}$ use a serial resistor R1 to reduce the. See derating curve.		
2	IRED Cathode	IRED cathode, internally connected to driver transistor		
3	Txd	Transmit Data Input, dynamically loaded for noise suppression.	I	HIGH
4	Rxd	Received Data Output, push-pull CMOS driver output capable of driving a standard CMOS or TTL load. No external pull-up or pull-down resistor is required. When disabled it is connected to $V_{logic}$ by a weak pull-up (500 k $\Omega$ ). Pin is current limited for protection against bus collisions due to programming errors.	O	LOW
5	SCLK	Serial Clock, dynamically loaded for noise suppression.	I	HIGH
6	$V_{CC}$	Supply Voltage		
7	$V_{logic}$	Supply voltage for digital part, 1.5 V to 5.5 V, defines logic swing for Txd, SCLK, and Rxd		
8	GND	Ground		

## Pinout

TFDU6108  
weight 200 mg

### "U" Option BabyFace (Universal)

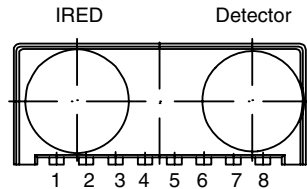

17087

### Definitions:

In the Vishay transceiver data sheets the following nomenclature is used for defining the IrDA operating modes:

SIR: 2.4 kbit/s to 115.2 kbit/s, equivalent to the basic serial infrared standard with the physical layer version IrPhy 1.0

MIR 576 kbit/s to 1152 kbit/s

FIR 4 Mbit/s

VFIR 16 Mbit/s

MIR and FIR were implemented with IrPhy 1.1, followed by IrPhy 1.2, adding the SIR Low Power Standard. IrPhy 1.3 extended the Low Power Option to MIR and FIR and VFIR was added with IrPhy 1.4. A new version of the standard in any obsoletes the former version.

## Absolute Maximum Ratings

Reference point Ground (pin 8) unless otherwise noted.

Typical values are for DESIGN AID ONLY, not guaranteed nor subject to production testing.

Parameter	Test Conditions	Symbol	Min	Typ.	Max	Unit
Supply voltage range, transceiver	$0\text{ V} < V_{CC2} < 6\text{ V}$	$V_{CC1}$	- 0.5		+ 6	V
Supply voltage range, transmitter	$0\text{ V} < V_{CC1} < 6\text{ V}$	$V_{CC2}$	- 0.5		+ 6	V
Supply voltage range, transceiver logic	$0\text{ V} < V_{CC1} < 6\text{ V}$	$V_{logic}$	- 0.5		+ 6	V
Input currents	for all pins, except IRED anode pin				10	mA
Output sinking current					25	mA
Junction temperature		$T_J$			125	°C
Power dissipation	see derating curve, figure 4	$P_D$			350	mW
Ambient temperature range (operating)		$T_{amb}$	- 25		+ 85	°C
Storage temperature range		$T_{stg}$	- 40		+ 100	°C
Soldering temperature	see recommended solder profile (see figure 3)				240	°C
Average output current		$I_{IRED (DC)}$			130	mA
Repetitive pulse output current	$< 90\ \mu\text{s}, t_{on} < 20\ %$	$I_{IRED (RP)}$			600	mA
IRED anode voltage		$V_{IREDA}$	- 0.5		+ 6	V
Transmitter data input voltage		$V_{Txd}$	- 0.5		$V_{logic} + 0.5$	V
Receiver data output voltage		$V_{Rxd}$	- 0.5		$V_{logic} + 0.5$	V
Virtual source size	Method: (1 - 1/e) encircled energy	d	2.5	2.8		mm
Maximum Intensity for Class 1 Operation of IEC825-1 or EN60825-1, edition Jan. 2001*) IrDA specified maximum limit	unidirectional operation, worst case IrDA FIR pulse pattern				Internally limited to class 1 500	mW/sr

\*) Due to the internal measures the device is a "class1" device. It will not exceed the IrDA intensity limit of 500 mW/sr.

## Electrical Characteristics

## Transceiver

$T_{amb} = 25\text{ }^{\circ}\text{C}$ ,  $V_{CC} = 2.7\text{ V}$  to  $5.5\text{ V}$  unless otherwise noted.

Typical values are for DESIGN AID ONLY, not guaranteed nor subject to production testing.

Parameter	Test Conditions	Symbol	Min	Typ.	Max	Unit
Supply voltage		$V_{CC1}$	2.7		5.5	V
		$V_{logic}$	1.5		5.5	V
Dynamic supply current <sup>1)</sup>	$T = -25\text{ }^{\circ}\text{C}$ to $85\text{ }^{\circ}\text{C}$ active, no signal $E_e = 0\text{ klx}$	$I_{CC1}$		2.0	2.35	mA
	$T = 25\text{ }^{\circ}\text{C}$				2.3	mA
	$T = -25\text{ }^{\circ}\text{C}$ to $85\text{ }^{\circ}\text{C}$ idle active, no load $E_e = 0\text{ klx}$	$I_{logic}$			5	$\mu\text{A}$
	$T = -25\text{ }^{\circ}\text{C}$ to $85\text{ }^{\circ}\text{C}$ $E_e = 1\text{ klx}^{2)}$ receive mode, $E_{EO} = 100\text{ mW/m}^2$ (9.6 kbit/s to 4.0 Mbit/s), $RL = 10\text{ k}\Omega$ to $V_{logic} = 5\text{ V}$ , $CL = 15\text{ pF}$	$I_{logic}$		160	1	$\mu\text{A}$
Shutdown supply current	inactive, set to shutdown mode $T = 25\text{ }^{\circ}\text{C}$ , $E_e = 0\text{ klx}$	$I_{SD}$			1	$\mu\text{A}$
	inactive, set to shutdown mode $T = 25\text{ }^{\circ}\text{C}$ , $E_e = 1\text{ klx}^{2)}$	$I_{SD}$			1.5	$\mu\text{A}$
	shutdown mode, $T = 85\text{ }^{\circ}\text{C}$ , not ambient light sensitive	$I_{SD}$			5	$\mu\text{A}$
Operating temperature range		$T_A$	-25		+85	$^{\circ}\text{C}$
Output voltage low	$C_{load} = 15\text{ pF}$ , $V_{logic} = 5\text{ V}$	$V_{OL}$		0.5	0.8	V
Output voltage high	$C_{load} = 15\text{ pF}$ , $V_{logic} = 5\text{ V}$	$V_{OH}$	$V_{logic} - 0.5$			V
Input voltage low (Txd, SCLK)	CMOS level <sup>3)</sup>	$V_{IL}$			$0.15^{2)}$ $V_{logic}$	V
Input voltage high (Txd, SCLK)	CMOS level <sup>3)</sup>	$V_{IH}$	$0.9^{2)}) V_{logic}$			V
Input leakage current (Txd, SCLK)		$I_L$	-10		+10	$\mu\text{A}$
Input capacitance		$C_{IN}$			5	pF

<sup>1)</sup> Receive mode only. In transmit mode, add the averaged programmed current of IRED current as  $I_{CC2}$

<sup>2)</sup> Standard Illuminant A

<sup>3)</sup> The typical threshold level is between  $0.5 \times V_{logic}/2$  ( $V_{logic} = 3\text{ V}$ ) and  $0.4 \times V_{logic}$  ( $V_{logic} = 5.5\text{ V}$ ). With that the device will work with less tight levels than the specified min/ max values. However, it is recommended to use the specified min/max values to avoid increased operating/standby supply currents.

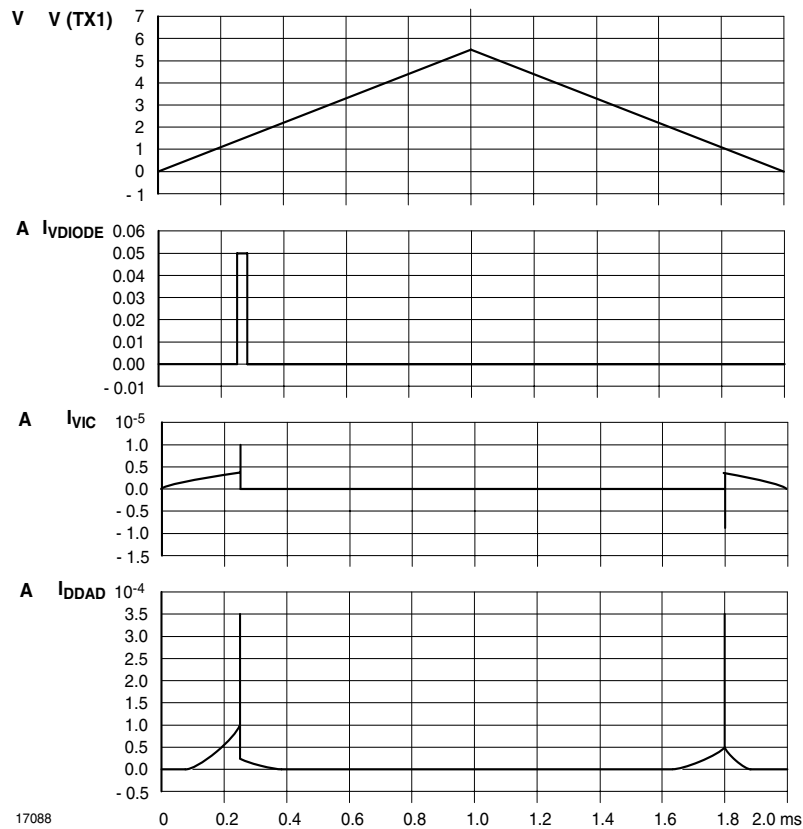

## Input Load

The waveform "I<sub>DDadd</sub>" shows the additional operating current of one input buffer (in this case Txd) vs. the logic input voltage V (TXI) for the digital supply

voltage V<sub>dd</sub> = 3 V under typical working conditions. The current "I<sub>VIC</sub>" is the typical input current vs. the input voltage.

## Optoelectronic Characteristics

### Receiver

T<sub>amb</sub> = 25 °C, V<sub>CC</sub> = 2.7 V to 5.5 V unless otherwise noted.

Typical values are for DESIGN AID ONLY, not guaranteed nor subject to production testing.

Parameter	Test Conditions	Symbol	Min	Typ.	Max	Unit
Minimum detection threshold irradiance, SIR mode	9.6 kbit/s to 115.2 kbit/s λ = 850 nm to 900 nm	E <sub>e</sub>		25	40	mW/m <sup>2</sup>
Minimum detection threshold irradiance, MIR mode	1.152 Mbit/s λ = 850 nm to 900 nm	E <sub>e</sub>		65		mW/m <sup>2</sup>
Minimum detection threshold irradiance, FIR mode	4.0 Mbit/s λ = 850 nm to 900 nm	E <sub>e</sub>		85	90	mW/m <sup>2</sup>
Maximum detection threshold irradiance	λ = 850 nm to 900 nm	E <sub>e</sub>	5	10		kW/m <sup>2</sup>

Parameter	Test Conditions	Symbol	Min	Typ.	Max	Unit
Logic LOW receiver input irradiance	optical ambient noise suppression up to this level for e.g. fluorescent light tolerance equivalent to the IrDA® "Background Light and Electromagnetic Field" specification	$E_e$	4			mW/m <sup>2</sup>
Rise time of output signal	10 % to 90 %, @ 2.2 k $\Omega$ , 15 pF	$t_r$ (Rxd)			40	ns
Fall time of output signal	90 % to 10 %, @ 2.2 k $\Omega$ , 15 pF	$t_f$ (Rxd)			40	ns
Rxd pulse width of output signal, 50 % SIR mode	input pulse length 20 $\mu$ s, 9.6 kbit/s	$t_{PW}$	1.3	2	3	$\mu$ s
	input pulse length 1.41 $\mu$ s, 115.2 Mbit/s	$t_{PW}$	1.2		3	$\mu$ s
Rxd pulse width of output signal, 50 % MIR mode	input pulse length 217 ns, 1.152 Mbit/s	$t_{PW}$	110		260	ns
Jitter, leading edge, MIR mode	input irradiance = 100 mW/m <sup>2</sup> , 1.152 Mbit/s				20	ns
Rxd pulse width of output signal, 50 % FIR mode	input pulse length 125 ns, 4.0 Mbit/s	$t_{PW}$	100		160	ns
Jitter, leading edge, FIR mode	input irradiance = 100 mW/m <sup>2</sup> , 4 Mbit/s				20	ns
Latency		$t_L$			120	$\mu$ s

## Transmitter

$T_{amb} = 25\text{ }^\circ\text{C}$ ,  $V_{CC} = 2.7\text{ V}$  to 5.5 V unless otherwise noted.

Typical values are for DESIGN AID ONLY, not guaranteed nor subject to production testing.

Parameter	Test Conditions	Symbol	Min	Typ.	Max	Unit
IREC operating current internally controlled, programmable using the "serial interface" programming sequence, see Appendix	$V_{CC1} = 3.3\text{ V}$ , the maximum current is limited internally. An external resistor can be used to reduce the power dissipation at higher operating voltages, see derating curve.	$I_D$		8 15 30 60 110 220 500	600	mA
Max. output radiant intensity	$V_{CC1} = 3.3\text{ V}$ , $\alpha = 0^\circ$ , $15^\circ$ , Txd = High, R1 = 0 $\Omega$ programmed to max. power level	$I_e$		0.3		mW/sr/mA
Output radiant intensity	$V_{CC1} = 3.3\text{ V}$ , $\alpha = 0^\circ$ , $15^\circ$ , Txd = Low, R1 = 0 $\Omega$ programmed to shutdown mode	$I_e$			0.04	mW/sr
Output radiant intensity, angle of half intensity		$\alpha$		$\pm 24$		$^\circ$
Peak - emission wavelength		$\lambda_p$	880		900	nm
Spectral bandwidth		$\Delta\lambda$		40		nm
Optical rise time, fall time		$t_{ropt}$ , $t_{fopt}$	10		40	ns
Optical overshoot					10	%

## Recommended Circuit Diagram

Operated with a low impedance power supply the TFDU6108 needs no external components. However, depending on the entire system design and board layout, additional components may be required (see figure 1).

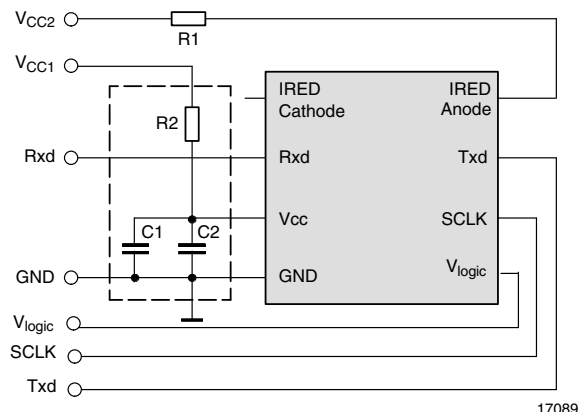

Figure 1. Recommended Application Circuit  
All external components (R, C) are optional

Vishay Semiconductor transceivers integrate a sensitive receiver and a built-in power driver. The combination of both needs a careful circuit board layout. The use of thin, long, resistive and inductive wiring should be avoided. The inputs (Txd, SCLK) and the output Rxd should be directly (DC) coupled to the I/O circuit. R1 is used for controlling the maximum current through the IR emitter. This one is necessary when operating over the full range of operating temperature and  $V_{CC1}$  - voltages above 4 V. For increasing the max. output power of the IRED, the value of the resistor should be reduced. It should be dimensioned to keep the IRED anode voltage below 4 V for using the full temperature range. For device and eye protection the pulse duration and current are internally limited.

R2, C1 and C2 are optional and dependent on the quality of the supply voltage  $V_{CC1}$  and injected noise. An unstable power supply with dropping voltage during transmission may reduce sensitivity (and transmission range) of the transceiver.

The placement of these parts is critical. It is strongly recommended to position C2 close to the transceiver power supply pins. An electrolytic capacitor should be used for C1 while a ceramic capacitor is used for C2.

## Recommended Application Circuit Components

Component	Recommended Value
C1	4.7 $\mu$ F, 16 V
C2	0.1 $\mu$ F, Ceramic, 16V
R1	<b>Recommended for <math>V_{CC1} \geq 4</math> V</b> Depending on current limit
R2	47 $\Omega$ , 0.125 W

## I/O and Software

For operating the device from a Controller I/O a driver software must be implemented.

## Mode Switching

The generic IrDA "Serial Interface programming" needs no special settings for the device. Only the current control table must be taken into account. For the description see the Appendix and the IrDA "Serial Interface specification for transceivers"

## Recommended Solder Profile

Solder Profile for Sn/Pb soldering

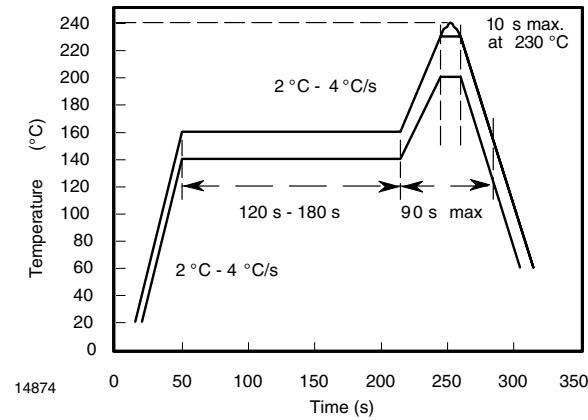

Figure 2. Recommended Solder Profile

## Lead-Free, Recommended Solder Profile

The TFDU6108 is a lead-free transceiver and qualified for lead-free processing. For lead-free solder paste like Sn<sub>(3.0 - 4.0)</sub>Ag<sub>(0.5 - 0.9)</sub>Cu, there are two standard reflow profiles: Ramp-Soak-Spike (RSS) and Ramp-To-Spike (RTS). The Ramp-Soak-Spike profile was developed primarily for reflow ovens heated by infrared radiation. Shown below in figure 3 is Vishay's recommended profile for use with the TFDU6108 transceivers. For more details please refer to Application note: SMD Assembly Instruction.

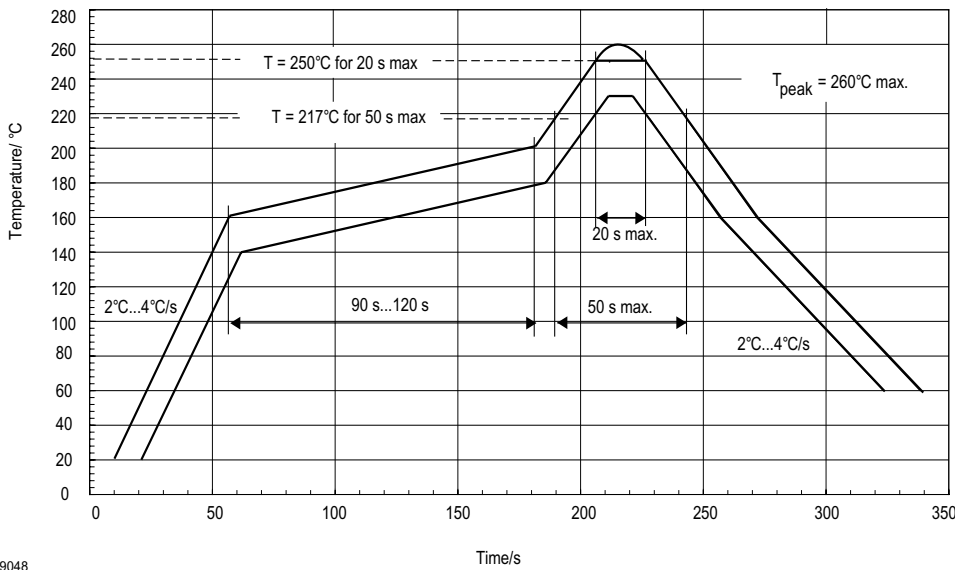

Figure 3. Solder Profile, RSS Recommendation



## Current Derating Diagram

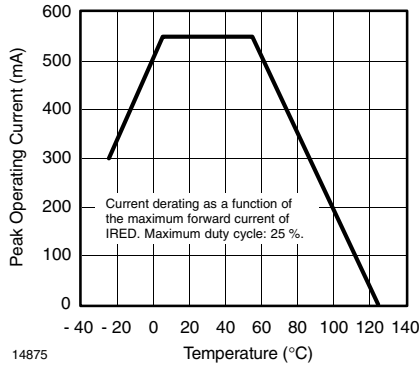
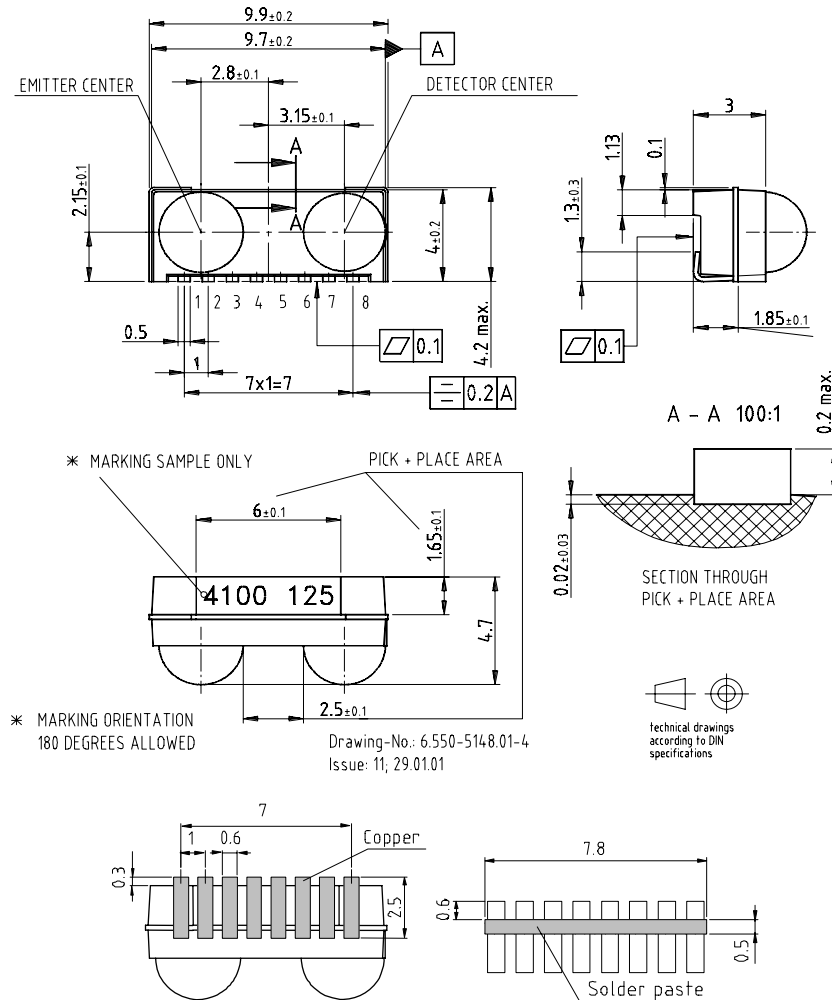

Figure 4. Current Derating Diagram

## Package Dimensions in mm



## Appendix A

When no infrared communication is in progress and the serial bus is idle, the IRTX line is kept low and IRRX is kept high.

### Serial Interface Implementation Basics of the IrDA Definitions

The data lines are multiplexed with the transmitter and receiver signals and separate clocks are used since the transceivers respond to the same address.

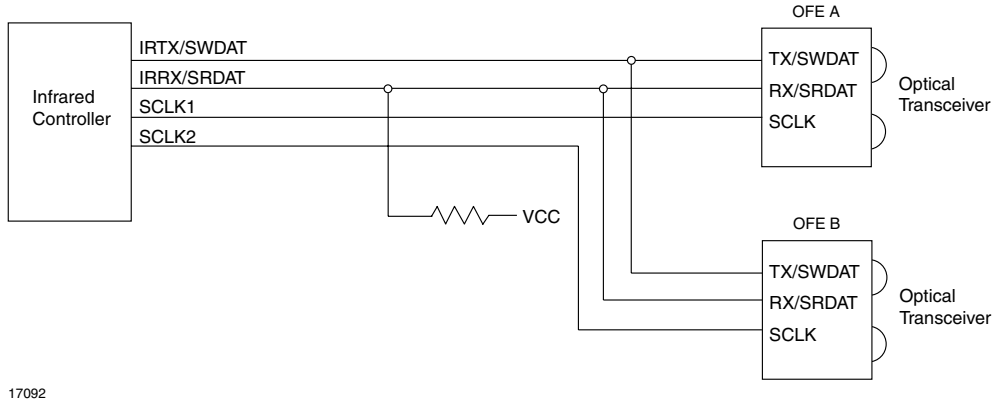

17092

Figure 5. Interface to Two Infrared Transceivers

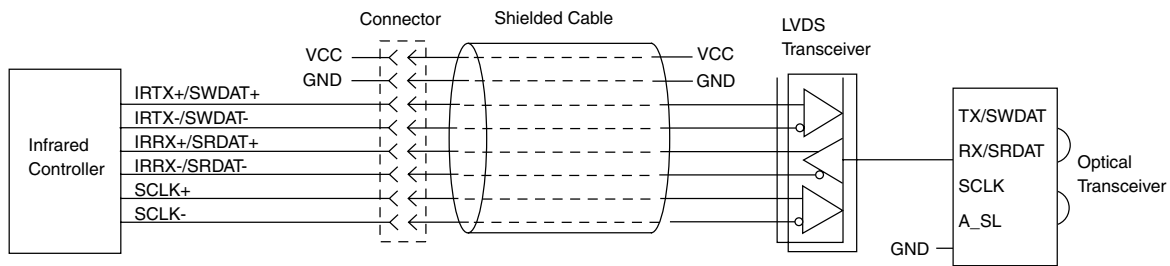

17093

Figure 6. Infrared Dongle with Differential Signaling

## Functional description

The serial interface is designed to interconnect two or more devices. One of the devices is always in control of the serial interface and is responsible for starting every transaction. This device functions as the bus master and is always the infrared controller. The infrared transceivers act as bus slaves and only respond to transactions initiated by the master. A bus transaction is made up of one or two phases. The first phase is the Command Phase and is present in every transaction. The second phase is the Response Phase and is present only in those transactions in which data must be returned from the slave. If the operation involves a data transfer from the slave, there will be a Response Phase following the Command Phase in which the slave will output the data.

The Response Phase, if present, must begin 4 clock cycles after the last bit of the Command Phase, as shown in figures 1 - 7 and 1 - 8, otherwise it is assumed that there will be no response phase and the master can terminate the transaction.

The SCLK line is always driven by the master and is used to clock the data being written to or read from the slave.

This line is driven by a totem-pole output buffer. The SCLK line is always stopped when the serial interface is idle to minimize power consumption and to avoid any interference with the analog circuitry inside the slave. There are no gaps between the bytes in either the Command or Response Phase. Data is always transferred in Little Endian order (least significant bit first). Input data is sampled on the rising edge of SCLK. IRTX/SWDAT output data from the controller is clocked by SCLK falling edge. IRRX/SRDAT output data from the slave is clocked by SCLK rising edge. Each byte of data in both Command and Response Phases is preceded by one start bit. The data to be written to the slave is carried on the IRTX/SWDAT line. When the control interface is idle, this line carries the infrared data signal used to drive the transmitter LED. When the first low-to-high transition on SCLK is detected at the beginning of the command sequence, the slave will disable the transmitter LED. The infrared controller then outputs the command string on the IRTX/SWDAT line. On the last SCLK cycle of the command sequence the slave re-enables the transmitter LED and normal infrared transmission can resume. No transition on SCLK must occur until the next command sequence otherwise the slave will disable the transmitter LED again. Read data is carried on the IRRX/SRDAT line. The slave disables the internal signal from the receiver photo diode during

the response phase of a read transaction. The addressed slave will output the read data on the IRRX/SRDAT line regardless of the setting of the Receiver Output Enable bit in the Mode Selection register 0. Non addressed slaves will tri-state the IRRX/SRDAT line. When the transceiver is powered up, the IRTX/SWDAT line should be kept low and SCLK should be cycled at least 30 times by the infrared controller before the first command is issued on the IRTX/SWDAT line. This guarantees that the transceiver interface circuitry will properly initialize and be ready to receive commands from the controller. In case of a multiple transceiver configuration, only one transceiver should have the receiver output enabled. A series resistor (approx. 200 ohms) should be placed on the receiver output from each transceiver to prevent large currents in case a conflict occurs due to a programming error.

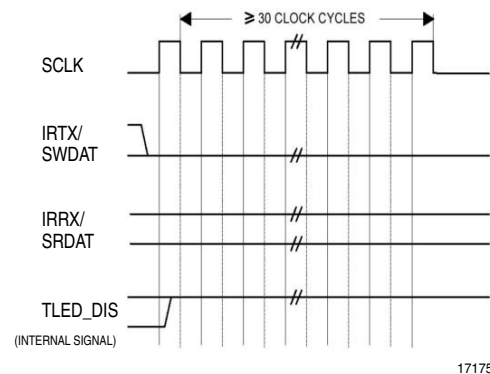

Figure 7. Initial Reset Timing

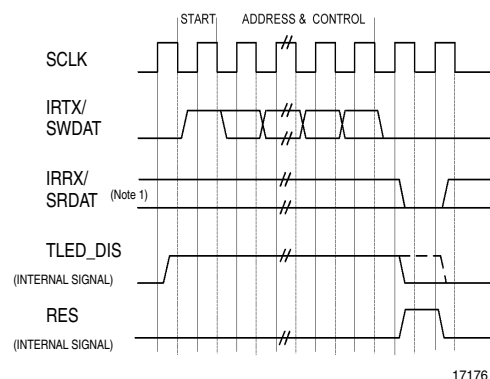

Figure 8. Special Command Waveform

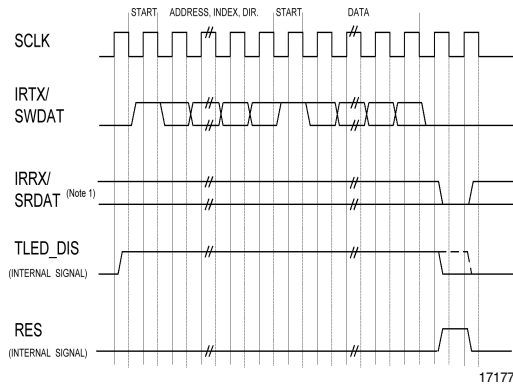

Figure 9. Write Data Waveform

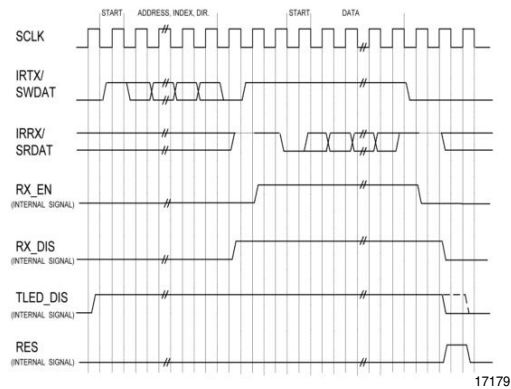

Figure 11. Read Data Waveform

Note 1: If the APEN bit in control register 0 is set to 1, the internal signal from the receiver photo diode is disconnected and the IRRX/SRDAT line is pulsed low for one clock cycle at the end of a write or special command.

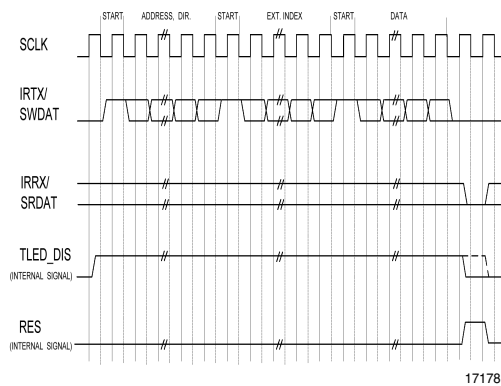

Figure 10. Write Data Waveform with Extended Index

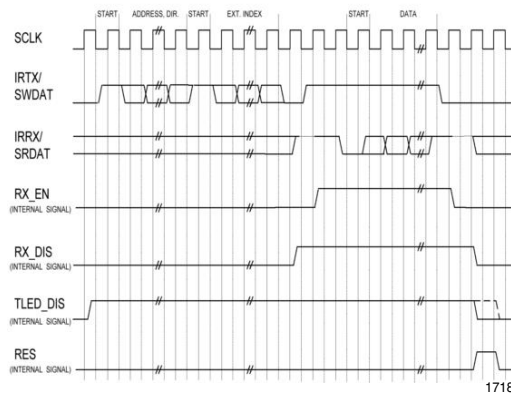

Figure 12. Read Data Waveform with Extended Index

Note 2: During a read transaction the infrared controller sets the IRTX/SWDAT line high after sending the address and index byte (or bytes). It will then set it low two clock cycles before the end of the transaction. It is strongly recommended that optical transceivers monitor this line instead of counting clock cycles in order to detect the end of the read transaction. This will always guarantee correct operation in case two or more transceivers from different manufacturers are sharing the serial interface.

**Switching Characteristics**

 Maximum capacitive load = 20 pF<sup>1)</sup>

Parameters	Test Conditions	Symbol	Min.	Max.	Unit
SCLK Clock Period	R.E., SCLK to next R.E., SCLK	tCKp	250	infinity	ns
SCLK Clock High Time	At 2.0 V for single-ended signals	tCKh	60		ns
SCLK Clock Low Time	At 0.8 V for single-ended signals	tCKl	80		ns
Output Data Valid (from infrared controller)	After F.E., SCLK	tDOtv		40	ns
Output Data Hold (from infrared controller)	After F.E., SCLK	tDOth	0		ns
Output Data Valid (from optical transceiver)	After R.E., SCLK	tDOrv		40	ns
Output Data Hold (from optical transceiver)	After R.E., SCLK	tDOrh		40	ns
Line Float Delay	After R.E., SCLK	tDOrf		60	ns
Input Data Setup	Before R.E., SCLK	tDIs	10		ns
Input Data Hold	After R.E., SCLK	tDIh	5		ns

<sup>1)</sup> Capacitive load is different from "Serial interface - specification". For the bus protocol see "**RECOMMENDED SERIAL INTERFACE FOR TRANSCEIVER CONTROL, Draft Version 1.0a, March 29, 2000, IrDA**".

In Appendix B the transceiver related data are given.



## Appendix B

### Application Guideline

In the following some guideline is given for handling the TFDU6108 in an application ambient, especially for testing. It is also a guideline for interfacing with a controller. We recommend to use for first evaluation the Vishay IRM1802 controller. For more information see the special data sheet. Driver software is available on request. Contact [irdc@vishay.com](mailto:irdc@vishay.com).

### Serial Interface Capability of the Vishay IrDA Transceivers Abstract

A serial interface allows an infrared controller to communicate with one or more infrared transceivers. The basic specification of IrDA<sup>®</sup> specified interface is described in "Serial Interface for Transceiver Control, v 1.0a", IrDA.

This part of the document describes the capabilities of the serial interface implemented in the Vishay IrDA transceivers TFDU8108 and TFDU6108. The VFIR (16 Mbit/s) and FIR (4 Mbit/s) programmable versions are using the same interface specification (with specific identification and programming).

### IrDA Serial Interface Basics

The serial interface for transceiver control (SITC) is a master/slave synchronous serial bus which uses the Txd and Rxd as data lines and the SCLK as clock line with a minimum period of 250 ns. The transceiver works always as slave and jump into SITC mode on the first rising edge of the clock line remaining there until the command phase is finished. After power on it is required an initial phase for  $\geq 30$  clock cycles at Txd is continuous low before the transmitter can be programmed. If Txd assume high during the initial phase then must start the initial phase again.

The data transfer is organized by one byte preceded by one start bit. The SITC allows the communication between infrared controller and transceiver through write and read transaction. The SITC consists of two store blocks with different functions. The store block called Extended Indexed Registers contain the various supported functionality of the device and can be read only. The other Main Control Registers allow write and read transaction and store the executable configuration of the device.

Any configuration is executed after the command phase is completed.

### Power - up defaults

After power on the transceiver has to stay by definition in the following default mode shown in the table. The default mode of the TFDU6108 is different from the originally defined IrDA Serial Interface default mode. The implemented deviation from the standard was a market request because only in this way a requested quick function test is possible with the TFDU6108 without the need to connect to a programming device.

Function	TFDU6108
Power Mode	active (!)
RX	active
TX_LED	active
APEN	enabled
Infrared Mode	SIR
Transmitter Power	defined SIR level

### Addressing

The transceiver is addressable with three address bits. There are individual and common addresses with the following values.

Description	Mask programmable	Address value A [2:0]
Individual address		001
Common (broadcast) address		111

## Data Acknowledgement

Data acknowledgement generated by the slave is available if the APEN bit is set to 1 in the common control register. In IrDA default state this functionality is disabled. In default state of the TFDU6108 it is enabled (see above). It is strongly recommended that this functionality is enabled to be on the safe side for correct data transmission during SITC mode.

## Registers Data Depth

In general the whole data registers consist of a data depth of eight bits. But sometimes it is unnecessary to implement the full depth. In such a case the invisible bits consider like a zero.

## Used Index Commands

The table shows the valid index commands, its allowable modes, and the data depth to them.

Commands INDEX [3:0]	Mode	Action	Register Name	Data Bits	Default Value TFDU6108
0h	W/R	Common control	main-ctrl-0 register	[4:2:0]	14h
1h	W/R	Infrared mode	main-ctrl-1 register	[3:0]	00h
2h	W/R	Txd power level	main-ctrl-2 register	[7:4]	70h
Bh - 3h	X	Not used			
Ch	X	Not used			
Dh	W	Reset transceiver, Only one byte!			
	R	Not used			
Eh	X	Not used			
Fh	W	Not used			
	R	Extended indexing			

## Main-ctrl-0 register values

Value	Function	Default
bit 0	PM SL - Power Mode Select 0 ≥ low power mode (sleep mode) 1 ≥ normal operation power mode	active (!)
bit 1	RX OEN - Receiver Output Enable 0 ≥ IRRX/SRDAT line disable (tri-stated) 1 ≥ IRRX/SRDAT line enabled	active
bit 2	TLED EN - Transmitter LED Enable 0 ≥ disabled 1 ≥ enabled	active
bit 3	not used	not used
bit 4	APEN <sup>1)</sup>	enabled

<sup>1)</sup> APEN - Acknowledge Pulse Enable, (optional)

This bit is used to enable the acknowledge pulse. When it is set to 1 and RX OEN is 1 (receiver output enabled) the IRRX/SRDAT line will be pulsed low for one clock cycle upon successful completion of every write command or special command with individual (non broadcast) transceiver address. The internal signal from the receiver photo diode is disconnected when this bit is set to 1.

## Main-ctrl-1 register values

Value	Function
bit 0	SIR (default)
bit 1	MIR
bit 2	FIR
bit 3	Sharp IR <sup>®</sup> Apple Talk <sup>®</sup> (SIR functionality)

If any other value is tried to be written by the controller into the SIF, the transceiver will load 00h into the main\_ctrl\_1 register and will not give an acknowledgement

## Main-ctrl-2 register values

	bit 7	bit 6	bit 5	bit 4	bit 3	bit 2	bit 1	bit 0	Mode	Txd-IRED (mA)	Remark
8xh-Fxh	1	x	x	x	x	x	x	x	FIR > 1 m, not for SIR!	550 (switch, ext. R1!)	FIR standard, serial resistor is necessary for $V_{CC2} > 4 V$
7xh <sup>1)</sup>	0	1	1	1	x	x	x	x	SIR > 1 m FIR > 0.7 m	250	SIR More Ext. FIR LP
6xh	0	1	1	0					SIR > 0.70 m FIR > 0.45 m	125	Extended FIR Low Power
5xh	0	1	0	1					SIR > 0.50 m FIR > 0.30 m	60	FIR Low Power
4xh	0	1	0	0						(45)	
3xh	0	0	1	1					SIR > 0.35 m FIR > 0.20 m	30	SIR Low Power
2xh	0	0	1	0					SIR > 0.25 m FIR > 0.15 m	15	e.g. Docking station
1xh	0	0	0	1					SIR > 0.15 m FIR > 0.10 m	8	e.g. Docking station
0xh	0	0	0	0	x	x	x	x		0	

<sup>1)</sup> default setting

## Used Extended Indexed Registers

The table shows the valid extended indexed commands its allowable modes and the data depth to them.

Register Address E_INDEX [7:0]	Mode	Action	Data Bits	Fixed Value
00h	R	Manufactured ID	[7:0]	0:4h
01h	R	Device ID	[7:0]	[7:6] ≤ 11
04h	R	Receiver recovery time Power on stabilization	[6:4, 2:0]	24h
05h	R	Receiver stabilization SCKL max. frequency	[6:4, 2:0]	30h
06h	R	Common capabilities	[7:0]	03h
07h	R	Supported Infrared modes	[7:0]	0Fh
08h	R	Supported Infrared modes	0	01h



## Invalid Commands Handling

There are some commands and register addresses, which cannot be decoded by the SITC. The slave ignores such invalid data for the internal logic.

Below the different types and the slave reaction to them are shown.

Description	Master Command	Slave Reaction on IRRX/SRDAT
Invalid command in read mode	Index [3:0] & C = 0	no reaction
Invalid command in write mode	Index [3:0] & C = 1	No acknowledgement generating independent of the value of APEN
Valid command in invalid read mode	Index [3:0] & C = 0	no reaction
Valid command in invalid write mode	Index [3:0] & C = 1	No acknowledgement generating independent of the value of APEN
Valid command in invalid write mode and invalid data	Index [3:0] & C = 1	No acknowledgement generating independent of the value of APEN
Broadcast (common) address in read mode	A [2:0] = 111 & C = 0	no reaction

No reaction means that the slave does not start the respond phase.

## Reset

There is no external reset pin at Vishay IrDA transceivers. In case of transition error there are two ways to set the SITC in a defined state: The first one is power off. The second one is that the transceiver monitors the IRTX/SWDAT line in any state. If this line is assumed low for  $\geq 30$  clock cycles then the transceiver must be set to the command start state and set all registers to default implemented values.



## Appendix C

### Serial Interface (SIF) Programming Guide

The SIF port of this module allow an IR controller to communicate with it, get module ID and capability information, implement receiver bandwidth mode switching, LED power control, shutdown and some other functions.

This interface requires three signals: a clock line (SCLK) that is used for timing, and two unidirectional lines multiplexed with the transmitter (Txd, write) and receiver (Rxd, read) infrared signal lines.

The supported programming sequence formats are listed below:

- one-byte special commands
- two-byte write commands
- two-byte read commands
- three-byte read commands

The one-byte special command sequences are reserved for time-critical actions, while the two-byte write command is predominantly used to set basic transceiver characteristics. More information can be found in the IrDA document "Serial Interface for Transceiver Control, v 1.0a" on IrDA.org web site.

### Serial Interface Timing Specifications

In general, serial interface programming sequences are similar to any clocked-data protocol:

- there is a range of acceptable clock rates, measured from rising edge to rising edge
- there is a minimum data setup time before clock rising edges
- there is a minimum data hold time after clock rising edges

Recommended programming timing:

(4 kHz <) fclk < 8 MHz (4 kHz is a recommended value, according to the Serial Interface Standard quasi-static programming is possible)

TCLK > 125 ns (< 250 μs, see the remark for quasi-static programming above)

Tsetup > 10 ns

Thold > 10 ns

The timing diagrams below show the setup and hold time for Serial Interface programming sequences:

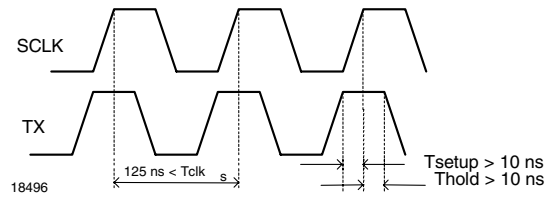

### Protocol Specifications

The serial interface protocol is a command-based communication standard and allows for the communication between controller and transceiver by way of serial programming sequences on the clock (SCLK), transmit (TX), and receive (RX) lines. The SCLK line is used as a clocking signal and the transmit/receive lines are used to write/read data information. The protocol requires all transceivers to implement the write commands, but does not require the read-portion of the protocol to be implemented (though all transceivers must at least follow the various commands, even if they perform no internal action as a result). This serial interface follows but does not support all read/write commands or extended commands, supporting only the special commands and basic write/read commands.

Write commands to the transceiver take place on the SCLK and TX lines and may make use of the RX line for answer back purposes.

A command may be directed to a single transceiver on the SCLK, TX and RX bus by specifying a unique three-bit transceiver address, or a command may be directed to all transceivers on the bus by way of a special three-bit broadcast address code. The Vishay VFIR transceiver TFDU8108 will respond to transceiver address 010 and the broadcast address 111 only, and follows but ignores all other transceiver addresses. The transceiver address of Vishay FIR module TFDU6108 is 001.

All commands have a common "header" or series of leading bits which take the form shown below.

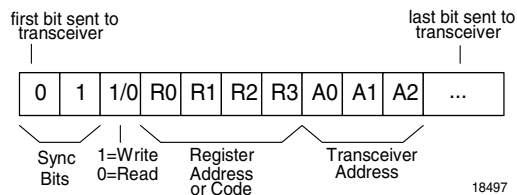

The bits shown are placed on the TX (DATA) line and clocked into the transceiver using the rising edge of the SCLK signal. Only the data bits are shown as it is assumed that a clock is always present, and that the transceiver samples the data on the rising edge of each clock pulse.

**Note:** as illustrated in the diagram above, the protocol uses "Little Endian" ordering of bits, so that the LSB is sent first, and the MSB is sent last for register addresses, transceiver addresses, and read/write data bytes. The notation that follows presents all addresses and data in LSB-to-MSB order (bits 0, 1, 2, 3, ... 7) unless otherwise stated.

### One-byte Special Commands

One-byte special commands are used for time-critical transceiver commands, such as full transceiver reset. A total of six special commands are possible, although only one command is available on the TFDU8108 and TFDU6108.

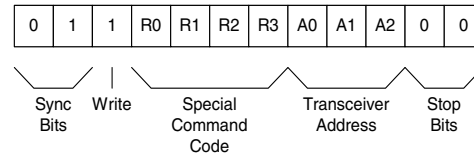

18498

Command	Module Type	Programming Sequence (Binary)	Programming Sequence (Hex)
RESET (Set all registers to default value)	TFDU6108	011 1011 100 00	3B
	TFDU8108	011 1011 010 00	5B

### Two-byte Write Commands

Two-byte write commands are used for setting the contents of transceiver registers which control transceiver such as shutdown/enable, receiver mode, LED power level, etc.

The register space requires four register address bits (R0-3), although three codes are used for controlling transceiver (see above), and the 1111 escape code is for extended commands. The 3-bit transceiver address (A0-3) is for selecting the destination, e.g. 010 to TFDU8108 and 001 to TFDU6108.

The second byte is data field (D0-7) for setting the characteristics of the transceiver module, e.g. SIR mode (00) or VFIR (05) when the register address is 0001.

The basic two-byte write command is illustrated below:

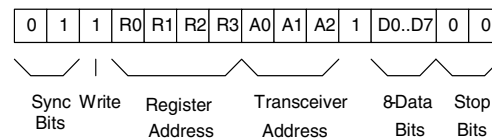

18499

## Vishay Semiconductors

Some important serial interface programming sequences are shown below:

Command		TFDU6108 Programming Sequence (Transceiver address: 001)	TFDU8108 Programming Sequence (Transceiver address: 010)
<b>Common Ctrl (0000)</b>	<b>Value (hex)</b>		
Normal (Enable all)	0F	011 0000 100 1 11110000 00	011 0000 010 1 11110000 00
Shutdown	00	011 0000 100 1 00000000 00	011 0000 010 1 00000000 00
<b>Receiver Mode (0001)</b>	<b>Value (hex)</b>		
SIR	00	011 1000 100 1 00000000 00	011 1000 010 1 00000000 00
MIR	01	011 1000 100 1 10000000 00	011 1000 010 1 10000000 00
FIR	02	011 1000 100 1 01000000 00	011 1000 010 1 01000000 00
Apple Talk	03	011 1000 100 1 11000000 00	011 1000 010 1 11000000 00
VFIR	05	011 1000 100 1 10100000 00	011 1000 010 1 10100000 00
Sharp-IR	08	011 1000 100 1 00010000 00	011 1000 010 1 00010000 00
<b>LED Power (0010)</b>	<b>Value (hex)</b>		
8 mA	1X	011 0100 100 1 00001000 00	011 0100 010 1 00001000 00
15 mA	2X	011 0100 100 1 00000100 00	011 0100 010 1 00000100 00
30 mA	3X	011 0100 100 1 00001100 00	011 0100 010 1 00001100 00
60 mA	5X	011 0100 100 1 00001010 00	011 0100 010 1 00001010 00
125 mA	6X	011 0100 100 1 00000110 00	011 0100 010 1 00000110 00
250 mA	7X	011 0100 100 1 00001110 00	011 0100 010 1 00001110 00
500 mA	FX	011 0100 100 1 00001111 00	011 0100 010 1 00001111 00

## Reel Dimensions

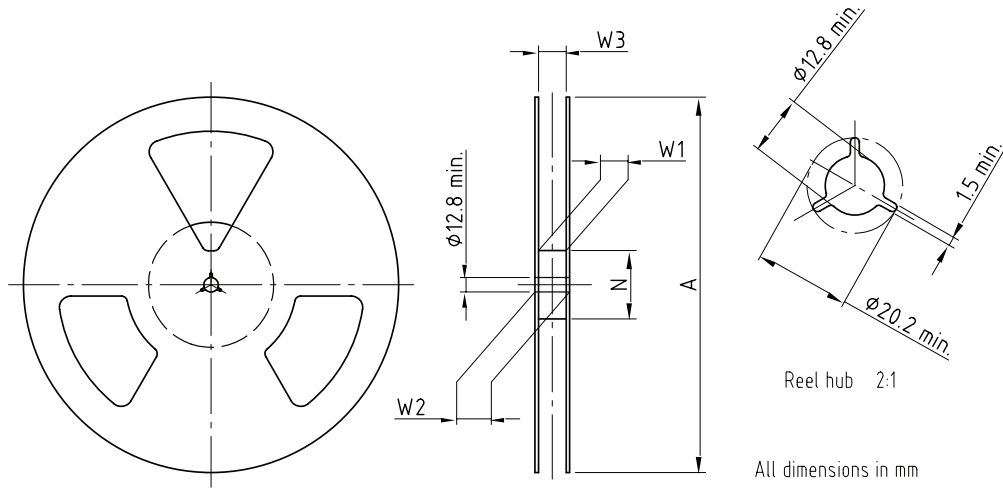

Drawing-No.: 9.800-5090.01-4  
 Issue: 1; 29.11.05  
 14017

Form of the leave open  
 of the wheel is supplier specific.

Dimension acc. to IEC EN 60 286-3

Technical drawings  
 according to DIN  
 specifications

Tape Width	A max.	N	W <sub>1</sub> min.	W <sub>2</sub> max.	W <sub>3</sub> min.	W <sub>3</sub> max.
mm	mm	mm	mm	mm	mm	mm
24	330	60	24.4	30.4	23.9	27.4

# TFDU6108

Vishay Semiconductors



## Tape Dimensions in mm

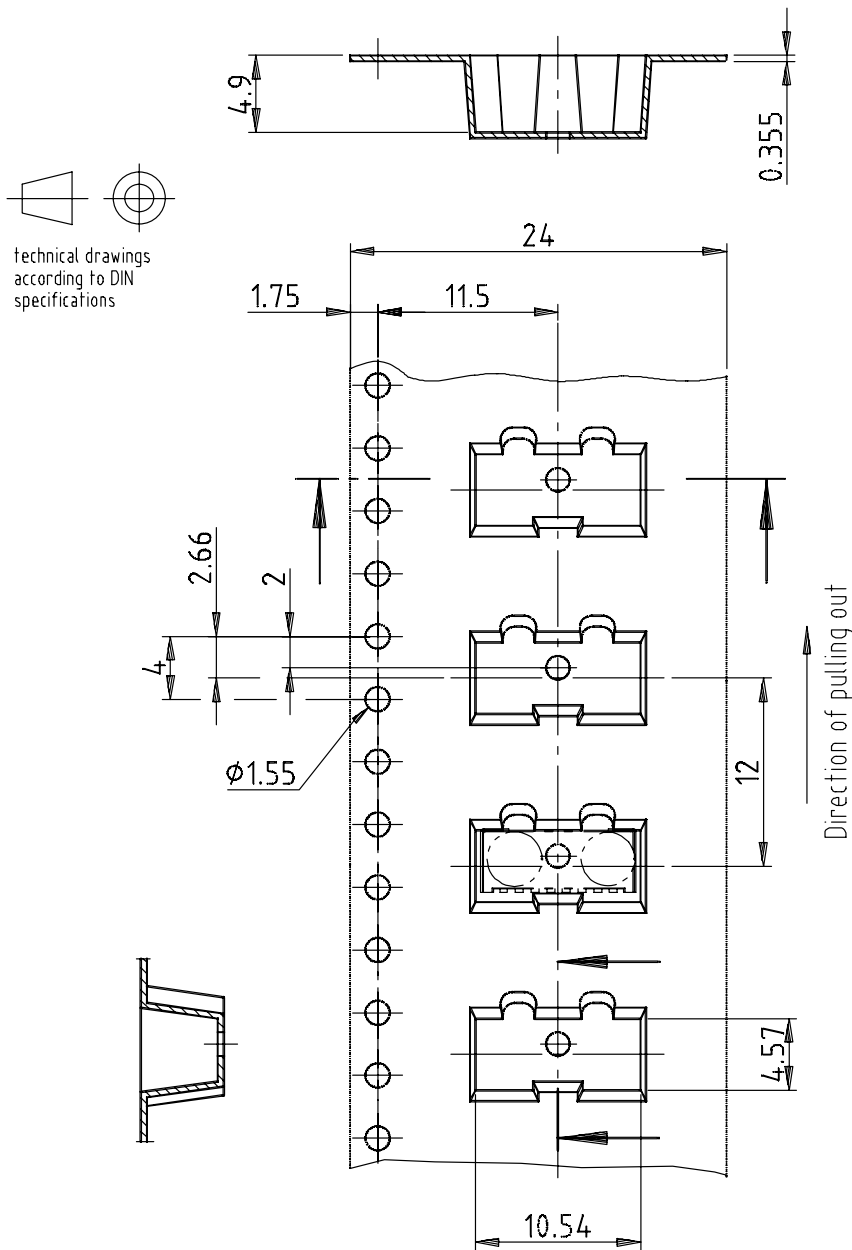

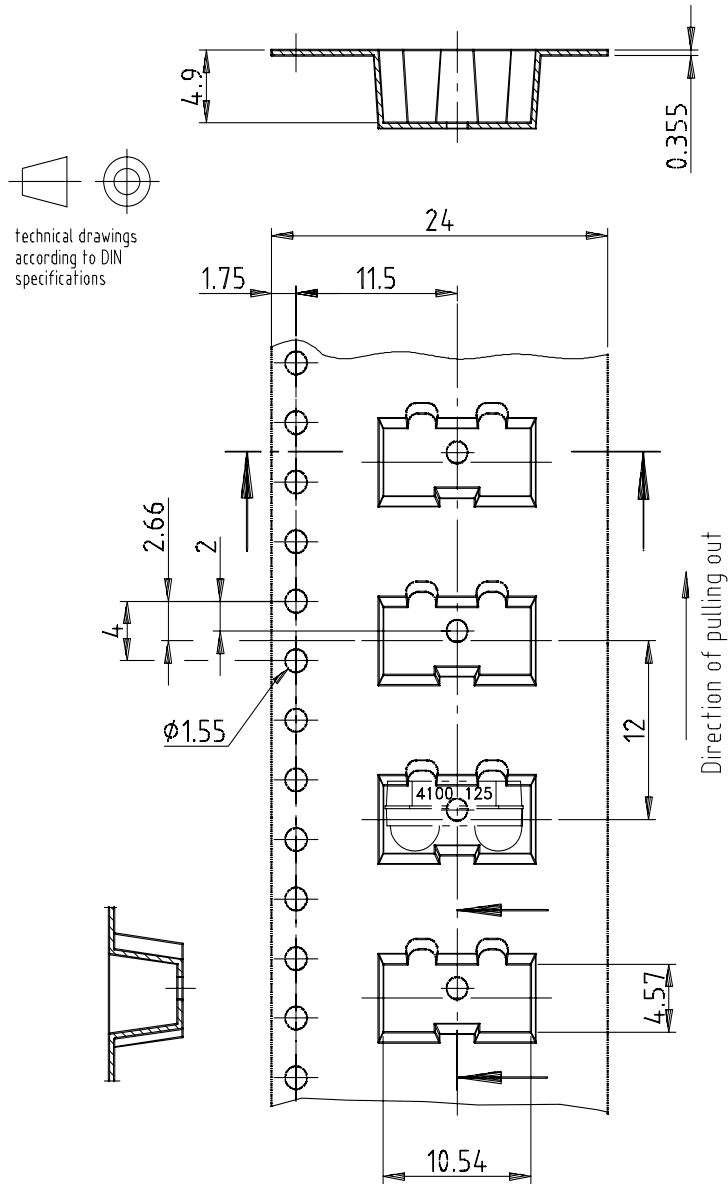

Drawing-No.: 9.700-5251.01-4  
Issue: 2; 07.05.01

18283



### Ozone Depleting Substances Policy Statement

It is the policy of Vishay Semiconductor GmbH to

1. Meet all present and future national and international statutory requirements.
2. Regularly and continuously improve the performance of our products, processes, distribution and operating systems with respect to their impact on the health and safety of our employees and the public, as well as their impact on the environment.

It is particular concern to control or eliminate releases of those substances into the atmosphere which are known as ozone depleting substances (ODSs).

The Montreal Protocol (1987) and its London Amendments (1990) intend to severely restrict the use of ODSs and forbid their use within the next ten years. Various national and international initiatives are pressing for an earlier ban on these substances.

Vishay Semiconductor GmbH has been able to use its policy of continuous improvements to eliminate the use of ODSs listed in the following documents.

1. Annex A, B and list of transitional substances of the Montreal Protocol and the London Amendments respectively
2. Class I and II ozone depleting substances in the Clean Air Act Amendments of 1990 by the Environmental Protection Agency (EPA) in the USA
3. Council Decision 88/540/EEC and 91/690/EEC Annex A, B and C (transitional substances) respectively.

Vishay Semiconductor GmbH can certify that our semiconductors are not manufactured with ozone depleting substances and do not contain such substances.

We reserve the right to make changes to improve technical design and may do so without further notice.

Parameters can vary in different applications. All operating parameters must be validated for each customer application by the customer. Should the buyer use Vishay Semiconductors products for any unintended or unauthorized application, the buyer shall indemnify Vishay Semiconductors against all claims, costs, damages, and expenses, arising out of, directly or indirectly, any claim of personal damage, injury or death associated with such unintended or unauthorized use.

Vishay Semiconductor GmbH, P.O.B. 3535, D-74025 Heilbronn, Germany





## Disclaimer

All product specifications and data are subject to change without notice.

Vishay Intertechnology, Inc., its affiliates, agents, and employees, and all persons acting on its or their behalf (collectively, "Vishay"), disclaim any and all liability for any errors, inaccuracies or incompleteness contained herein or in any other disclosure relating to any product.

Vishay disclaims any and all liability arising out of the use or application of any product described herein or of any information provided herein to the maximum extent permitted by law. The product specifications do not expand or otherwise modify Vishay's terms and conditions of purchase, including but not limited to the warranty expressed therein, which apply to these products.

No license, express or implied, by estoppel or otherwise, to any intellectual property rights is granted by this document or by any conduct of Vishay.

The products shown herein are not designed for use in medical, life-saving, or life-sustaining applications unless otherwise expressly indicated. Customers using or selling Vishay products not expressly indicated for use in such applications do so entirely at their own risk and agree to fully indemnify Vishay for any damages arising or resulting from such use or sale. Please contact authorized Vishay personnel to obtain written terms and conditions regarding products designed for such applications.

Product names and markings noted herein may be trademarks of their respective owners.