

DESCRIPTION

The LX1689 is the latest generation Direct Drive CCFL (Cold Cathode Fluorescent Lamp) Controller. It uses new circuit design techniques (patents pending) and combines digital and linear circuits with an advanced BiCMOS process to create a more complete controller in a small package.

When compared to the original LX1686 design, identical module applications use from 12 to 30 less components. New functions and enhancements have been added to make the LX1689 even easier to use.

The on-chip PLL circuit used to synchronize the digital dimming burst frequency to the video frame rate, as used in the LX1686, is replaced with a programmable counter. This counter can divide the video controller horizontal sync pulse, other external clock source or the internal chip clock source to generate the burst frequency.

The brightness control input allows the use of either a DC voltage or a PWM input to simplify design. Programmable polarity brightness control is retained, except in the case of externally clocked digital dimming. Two onboard LDO regulators extend the input voltage range of the IC up to 28 Volts without using external circuitry as was required with our previous controllers. The LX1689 includes a new lamp strike detection scheme that saves a package pin and three external components. Internal circuits monitor lamp current pulses at the I_{SNS} input to determine if the lamp strikes and if it stays ignited once operational.

Integrating full wave rectifiers for each of three lamp inputs has significantly reduced the lamp feedback component count. In addition the controller features include auto shutdown for open or broken lamps, and a lamp fault detection with a status reporting output.

IMPORTANT: For the most current data, consult MICROSEMI's website: <http://www.microsemi.com>
Protected By U.S. Patents: 5,615,093; 5,923,129; 5,930,121; 6,198,234; Patents Pending

KEY FEATURES

- 3 to 28 Volt Single Fixed ($\pm 20\%$) Supply Operating Range
- Selectable Analog/Digital Dimming Modes
- Digital Dimming Can Synch to External Or Internal Clocks
- User Programmable Digital Dimming Burst Frequency
- 252 mS Power On Delay
- Flexible Lamp Current Compensation Input
- Open Lamp Shutdown and Fault Output Indicator
- "On Chip" Full Wave Lamp Current & Voltage Rectifiers
- 20 Pin TSSOP Package

BENEFITS

- Low Component Count / Module Cost / Size
- High "Nits/Watt" Efficiency
- Operates Directly From 1 to 6 Li-Ion Cells
- Lamp Current Compensation Input Makes Indoor/Outdoor And Wide Temperature Range Applications Easy to Design

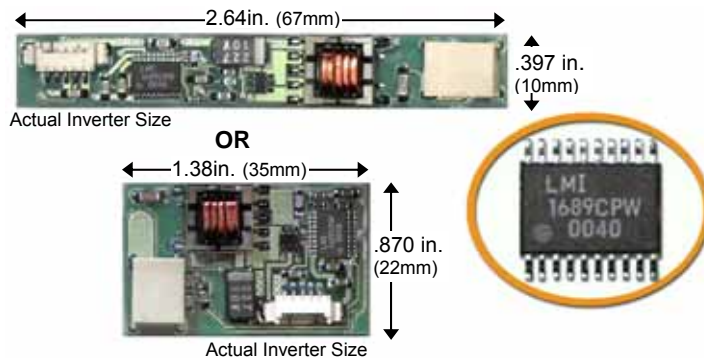
PRODUCT HIGHLIGHT
LX1689 CCFL Inverter Layouts Examples*

Bill of Materials

1	LX1689CPW
1	Transformer
1	Dual FET
2	Connectors
7	Resistors
9	Capacitors
21	Total Count

*As Shown in Figure 1 (Typical Application)

PACKAGE ORDER INFO

T _J (°C)	MIN V _{DD}	MAX V _{DD}	PW Plastic TSSOP 20-PIN
0 to 70	3V	28V	LX1689CPW
-40 to 85	3V	28V	LX1689IPW

Note: Available in Tape & Reel. Append the letters "TR" to the part number. (i.e. LX1689CPW-TR)

ABSOLUTE MAXIMUM RATINGS

Supply Voltage (V_{BATT}).....	30V
Digital Input (ENABLE).....	-0.3V to 7V
Analog Inputs Transient Peak (I_{SNS} , OC_{SNS} , OV_{SNS}).....	-25V to +25V
Analog Inputs (BRITE_IN, EA_IN).....	-0.3V to 5.5V
Digital Inputs (DIM_CLK, DIM_MODE, DIV_248)	-0.3V to 5.5V
Digital Output (A_{OUT} , B_{OUT})	-0.3V to $V_{DD_P} + 0.5V$
Analog Outputs (BRITE_C, I_R, BRITE_OUT, BRITE_R, EA_OUT) ...	-0.3V to $V_{DD_A} + 0.5V$
Storage Temperature Range	-65°C to 150°C
Maximum Operating Junction Temperature.....	150°C
RoHS / Pb-free Peak Package Solder Reflow Temperature (40 second maximum exposure).....	260°C (+0,-5)

Note: Exceeding these ratings could cause damage to the device. All voltages are with respect to Ground. Currents are positive into, negative out of specified terminal.

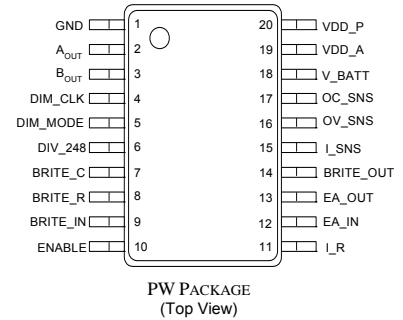
PACKAGE PIN OUT

RoHS / Pb-free 100% Matte Tin Lead Finish

THERMAL DATA
PW Plastic TSSOP 20-Pin

THERMAL RESISTANCE-JUNCTION TO AMBIENT, θ_{JA} | **144°C/W**

Junction Temperature Calculation: $T_J = T_A + (P_D \times \theta_{JA})$.

The θ_{JA} numbers are guidelines for the thermal performance of the device/pc-board system. All of the above assume no ambient airflow.

FUNCTIONAL PIN DESCRIPTION

PIN NAME	DESCRIPTION
GND	Ground
V_{DD_P}	Power V_{DD_P} Supply Output. This output pin is used to connect an external capacitor to stabilize and filter the on chip V_{DD_P} LDO regulator. The input of the LDO is the switched V_{BATT} supply. LDO output is normally 5.3V and is used only to drive the output buffers at A_{OUT} and B_{OUT} . The external capacitor will be a 100 to 1000nF ceramic dielectric. Up to 5mA DC additional load may be imposed by external circuitry. External load must be reduced if the combination of output current and input voltage exceeds power dissipation capability of the die.
A_{OUT}	A buffer N-FET driver output. The pin includes a internal 10K pull down resistor.
V_{DD_A}	Analog V_{DD_A} Supply Output. This output pin is used to connect an external capacitor to stabilize and filter the on chip V_{DD_A} LDO regulator. The input of the LDO is the switched V_{BATT} supply. LDO output is normally 2.95V and is used to drive all circuitry except the output buffers at A_{OUT} and B_{OUT} . Average internal load is 6mA. Up to 5mA DC additional load may be imposed by external circuitry. External load must be reduced if the combination of output current and input voltage exceeds power dissipation capability of the die. The external capacitor will be a 100 to 1000nF ceramic dielectric type.
B_{OUT}	B buffer N-FET driver output. The pin includes a internal 10K pull down resistor.
V_{BATT}	Voltage Input, 3 to 28V input range. V_{BATT} is switched (see ENABLE) to remove power from chip. Two LDO regulators follow the switch, one generates V_{DD_P} (see V_{DD_P}) and the other V_{DD_A} (see V_{DD_A}). Care must be taken in power distribution design to minimize transients and noise coupling from the V_{DD_P} output to the V_{DD_A} output. The external capacitor will be a 100 to 1000nF ceramic dielectric type.

FUNCTIONAL PIN DESCRIPTION (CONTINUED)

PIN NAME	DESCRIPTION
DIM_CLK	Digital Dimming Clock / Dimming Polarity. An input pin that may be selected to control burst frequency for external Digital Dimming. This input can be any clock signal up to 200KHz. This pin is also used to control the dimming polarity when operating in the analog or internal digital mode. If DIM_MODE is in the open condition (Analog Dimming Mode) the DIM_CLK input should be connected to VDD_A for conventional dimming polarity or set to Ground for reverse polarity. Conventional polarity means that lamp brightness increases with increasing voltage on the BRITE_IN pin. Reverse polarity means that brightness decreases with increasing voltage.
OC_SNS	Over Current Sense Input. A full wave AC voltage input centered on ground that is proportional to total high voltage transformer secondary winding current. The OC_SNS input is full wave rectified, then applied to a digital comparator with a 2V reference to cause peak voltages greater than 2V to digitally reset the PWM logic on a pulse by pulse basis. Frequency range of the input signal is 10kHz to 500KHz. Normal operating voltage levels should be under max $\pm 1.8\text{V}_{\text{PK}}$, and abnormal voltage can operate continuously as high as $\pm 10\text{V}$ peak under load fault conditions. Transients under fault conditions can reach $\pm 25\text{V}_{\text{PK}}$.
DIM_MODE	Dimming Mode Input. This three state input pin places the IC in Analog Dimming Mode, internal Digital Dimming Mode, or external Digital Dimming Mode. If the input is left open or forced to VDD_A / 2 Analog mode is selected. If connected to VDD_A, Digital Dimming with a external clock source applied to the DIM_CLK input is selected to the burst timing generator. If connected to Ground, Digital Dimming with a internal clock is selected. The internal clock is equivalent to the frequency at AOUT divided by two, both the internal or external clock frequency can be divided down by setting the DIV_248 pin. (see DIV_248)
OV_SNS	Over Voltage Sense Input. A full wave AC voltage input centered around ground that is proportional to lamp voltage. The OV_SNS input will be full wave rectified, then applied to a digital comparator with a 2V reference to cause peak voltage greater than 2V to digitally reset the PWM logic on a pulse by pulse basis. Frequency range of the input signal is 10KHz to 500KHz. Normal operating voltage levels should be under $\pm 1.8\text{V}_{\text{PK}}$, and abnormal voltage can operate continuously as high as $\pm 10\text{V}$ peak under load fault conditions. Transients under fault conditions can reach $\pm 25\text{V}_{\text{PK}}$. The input has a 10K pull down resistor that serves as a DC restorer to the external capacitor that divides down lamp voltage.
DIV_248	Divide Digital Dimming clock by 2, 4, or 8. This three state input pin causes the internal or external digital dimming clock source to be divided by one of the three values, 2, 4, or 8. Its purpose is to allow a selection of three possible burst rates for any given external or internal clock source. A high (VDD_A) selects divide by 2, open selects divide by 4, and ground selects divided by 8. We advise keeping burst above 95Hz and below about 400HZ. This will minimize visible flicker and possible audible noise from the power supply components.
I_SNS	Current Sense Input. A full wave AC voltage input centered around ground that is proportional to lamp current. The I_SNS input is full wave rectified and amplified, then presented to the inverting input of the current error amplifier through a 100K resistor. Frequency range of the input signal is 10KHz to 500KHz. Normal operating voltage levels will be in the range of ± 0.5 to 2.5V_{PK} , and abnormal voltage can operate continuously as high as $\pm 10\text{V}$ peak under load fault conditions. Transient under fault conditions can reach $\pm 25\text{V}_{\text{PK}}$. We strongly recommend a 10K resistor be placed in series with the pin to limit current from voltage spikes that can occur by intermittent lamp connectors, or arcing from a faulty high voltage transformer. This resistor will eliminate the possibility of IC damage under these fault conditions. The open lamp fault logic monitors the I_SNS pin voltage and number of lamp current cycles. If the number of lamp current cycles with amplitude below fault threshold are less than 8 in a given fault checking period then the strike latch will not be reset and a fault is declared, which shuts down the A/B outputs. In the strike mode, if no lamp current is detected after 15 attempts a fault is likewise declared. (See further LX1689 operation section)

FUNCTIONAL PIN DESCRIPTION (CONTINUED)

PIN NAME	DESCRIPTION
BRITE_C	BRITE Filter Capacitor and FAULT Output. Used to convert higher frequency digital PWM inputs to proportional DC currents at the BRITE_OUT pin. The capacitor forms a low pass filter with an internal 200K resistor. This pin will be driven to VDD_A if a lamp fault is detected by the LX1689. If no fault is present the voltage at this pin will vary from 50mV to 1.05V as BRITE_IN varies from 0 to 2V. A CMOS gate may be connected to this pin to sense the fault condition. TTL gates or other low impedance (less than 20 megohm) must not be connected to this node as their DC resistance will load the internal 200K resistor and create error in the BRITE_OUT current level.
EA_IN	Error Amp Inverting Input. Frequency Compensation input for the Error Amplifier. See EA_OUT below. A 100K, negative TC on chip resistor connected between the inverting input of the error amplifier and the output of the I_SNS full wave rectifier is the resistor in an R/C loop compensation network.
BRITE_R	Dedicated Bias resistor for BRITE_OUT current source.
EA_OUT	Error Amp Output. Error amplifier is a GM type and does not require a external capacitor for stability. An external capacitor is connected from this pin to EA_IN to adjust the loop response of the inverter module. This capacitor value can vary from 100pF to 5000pF in various applications. This capacitor may also be connected from the EA_OUT to ground.
BRITE_IN	Brightness Control Input. The input signal can be a DC voltage, a low frequency pulse width modulated digital signal, or a high frequency pulse width modulated digital signal. Active DC voltage range is 0.5 to 2.0V. Signals above 2V are clipped and signals below 0.5V make output current from the BRITE_OUT pin near zero. Low frequency digital PWM signals up to 500Hz can be applied to affect Digital Dimming. Higher frequency PWM signals, up to 100KHz are filtered to an equivalent DC current at the BRITE_OUT pin by adding a capacitor at the BRITE_C pin. On chip signal conditioning amplifiers clip inputs above 2V so that lamp current amplitude is not sensitive to the voltage level variations of a digital PWM input signal.
BRITE_OUT	Brightness Reference Current Output. This variable current source is the mirror of BRITE_R current multiplied by the voltage at BRITE_C (0 to 1.0V) when analog dimming is selected, or by 1.0V when digital dimming is selected. It becomes the reference voltage to the lamp current error amplifier when applied to an external precision resistor connected from the BRITE_OUT pin to ground. BRITE_OUT current: $I_{BRITE_OUT} = I_{BRITE_R} \times 1.0 \text{ (Digital Dimming Mode)}$ $I_{BRITE_OUT} = I_{BRITE_R} \times V_{BRITE_C} \text{ (Analog Dimming Mode)}$ $V_{BRITE_OUT} = I_{BRITE_R} \times R_{BRITE_OUT}$ $I_{BRITE_R} = \frac{1.00V}{R_{BRITE_R}}$
ENABLE	Chip Enable Input. If logic high, all functions are enabled. If logic low, internal power is disconnected from the V_BATT pin, disabling all functions. Logic threshold is about 1.2V. Maximum current into V_BATT when ENABLE < 0.3V, V_BATT < 28V, is 28 μA. ENABLE may be connected to V_BATT through a series resistor if the disable function is not used. Resistor tolerance is ± 10%; and R value is: $R = \frac{[V_{BATT_MIN} - 1.5V]}{30 \times 10^{-6} \text{ Amp}}$ <p>The Enable pin can be connected directly to 3.3/5V logic.</p>
I_R	Current Reference Resistor Input. Connects to an external resistor that determines the magnitude of internal bias currents. The nominal lamp frequency can be adjusted by varying this resistor value in the range of 10K to 150K Ohms. $I_{I_R} = \frac{1.00V}{R_{I_R}}$

RECOMMENDED OPERATING CONDITIONS

Parameter	LX1689			Units
	Min	Typ	Max	
Supply Voltage (V_{BATT})	3		28	V
Digital Input (ENABLE)	0		6.5	V
Analog Inputs (I_SNS, OC_SNS, OV_SNS)	-3		3	V_{PK}
BRITE_IN Linear DC Voltage Range	0.5		2	V
BRITE_IN PWM Logic Signal Voltage Range	0		5	V
Digital Inputs (DIM_MODE, DIV_248, DIM_CLK)	0		5.5	V
Maximum Output Gate Charge (A_{OUT} , B_{OUT})		10	20	nC

ELECTRICAL CHARACTERISTICS

Unless otherwise specified, the following specifications apply over the operating ambient temperature: LX1689CPW: $0^{\circ}\text{C} \leq T_A \leq 70^{\circ}\text{C}$, LX1689IPW: $-40^{\circ}\text{C} \leq T_A \leq 85^{\circ}\text{C}$, except where otherwise noted.

Test conditions: $V_{BATT} = 3.3$ to $28 V_{DC}$, $I_R = 80.6\text{K}\Omega$, $\text{BRITE}_R = \text{BRITE}_{OUT} = 10\text{K}\Omega$, $\text{BRITE}_C = \text{open}$, $I_{COMP} = 100\text{pf}$

Parameter	Symbol	Test Conditions	LX1689			Units
			Min	Typ	Max	
POWER						
Regulator Output Voltage	V_{DD_P}	$V_{BATT} = 6$ to 28V , I Load = $0 - 5\text{mADC}$	5.05	5.3	5.55	V
V_{DD_P} Drop Out Voltage	ΔV_{DD_P}	$\Delta V_{DD_P} = -1\%$, I Load = 5mADC ; $T_A = 25^{\circ}\text{C}$		50		mV
Regulator Output Voltage	V_{DD_A}	$V_{BATT} = 3.5$ to 28V , I Load = $0 - 5\text{mADC}$	2.75	2.95	3.15	V
V_{DD_A} Dropout Voltage	ΔV_{DD_A}	$\Delta V_{DD_A} = -1\%$, I Load = 5mADC ; $T_A = 25^{\circ}\text{C}$		100		mV
V_{BATT} Static Current	I_{BATT}			5.5	9	mA
V_{BATT} Dynamic Current	I_{BATT}	$C_{AOUT} = C_{BOUT} = 1000\text{pF}$		10	17	mA
Sleep Mode Current	I_{BATT_SLEEP}	$V_{ENABLE} \leq 0.4\text{V}$; $V_{BATT} = 5\text{V}$		2.8	5	μA
Sleep Mode Current	I_{BATT_SLEEP}	$V_{ENABLE} \leq 0.4\text{V}$; $V_{BATT} = 28\text{V}$		22	35	μA
ENABLE INPUT						
Run Threshold	V_{TH_ENRUN}			1.1	1.4	V
Shutdown Threshold	V_{TL_ENSHDN}		0.4	1.1		V
Input High Current	I_{IH_ENABLE}	ENABLE = 2V		2	12	μA
Input High Current	I_{IH_ENABLE}	ENABLE = 5V		35	80	μA
Input Low Current	I_{IL_ENABLE}	ENABLE = 0V	-1	0	1	μA
UNDER VOLTAGE LOCKOUT						
Startup Threshold	V_{T_UVLO}	Run Mode		2.55	2.8	V
UVLO Threshold		Shutdown Mode	2.1	2.35		V
UVLO Hysteresis	V_{H_UVLO}			200		mV

ELECTRICAL CHARACTERISTICS (CONTINUED)

Parameter	Symbol	Test Conditions	LX1689			Units
			Min	Typ	Max	
RAMP GENERATOR						
Max Strike / Run Frequency Ratio	F_{RAMP_STK}	Ratio to run frequency, $I_{SNS} = OV_{SNS} = 0V$	4	5	6	
Maximum Lamp Run Frequency	F_{RAMP_RUNMAX}	Lamp is ignited; $I_R = 10K$	250	450		KHz
Lamp Run Frequency	F_{LAMP_RUN}	Lamp is ignited ; $T_A = 25^\circ C$	63	65	67	KHz
Lamp Run Frequency	F_{LAMP_RUN}	Lamp is ignited	61	65	69	KHz
Lamp Run Frequency Regulation over V_{BATT}	F_{LAMP_REG}	$3.3 \leq V_{BATT} \leq 28V$		0.1		%
Internal Digital Dimming Burst Frequency	F_{BURST}	$DIV_{248} = VDD_A, DIM_MODE = 0V$		254		Hz
		$DIV_{248} = \text{Floating}, DIM_MODE = 0V$		127		Hz
		$DIV_{248} = \text{Gnd}, DIM_MODE = 0V$		63.5		Hz
BIAS BLOCK						
Voltage at Pin I_{IR}	V_{IR}	$V_{BATT} = 2.8V \text{ to } 28V, I_{OUT} = 0 \text{ to } 100\mu A, T_A = 25^\circ C$	0.95	1.0	1.05	V
Pin I_{IR} Max Source Current	I_{MAX_IR}	$I_{IR} = 0V$	100	700		μA
Voltage Reference Voltage (Internal node)	V_{ZPO}	$T_A = 25^\circ C$, reference use only	1.99	2	2.01	V
PWM BLOCK						
Error Amp Transconductance	G_{M_EAMP}		90	180		μmho
Error Amp Output Source Current	I_{S_EAMP}		5	12		μA
Error Amp Output Sink Current	I_{SK_EAMP}		5	12		μA
Error Amp Output High Voltage	V_{H_EAMP}	$BRITE_OUT - EA_IN = 50mV$	2.5	2.9		V
Error Amp Output Low Voltage	V_{L_EAMP}	$EA_IN - BRITE_OUT = 50mV$		0.015	0.5	V
Error Amp Input Offset Voltage	V_{OS_EAMP}				70	mV
Max Duty Cycle	DC_{MAX}			44		%
Ramp Valley Voltage	R_{VV}			200		mV
Ramp Peak Voltage	R_{PV}			1.95		V
OUTPUT BUFFER BLOCK						
Output Sink Current	I_{SK_OUTBUF}	$V_{AOUT}, V_{BOUT} = V_{DD_P}$		100		mA
Output Source Current	I_{S_OUTBUF}	$V_{AOUT}, V_{BOUT} = 0V$		100		mA
Output Rise Time	T_R	$C_{OUT} = 1000pF$		25	200	nS
Output Fall Time	T_F	$C_{OUT} = 1000pF$		25	200	nS
DIM_CLK INPUT						
Pull-up Resistance		To V_{DDA}		50		K Ω
Input High Threshold	$V_{TH_DIM_CLK}$	Conventional Dimming		0.9	1.4	V
Input Low Threshold	$V_{TL_DIM_CLK}$	Reverse Dimming	0.4	0.9		V
Input High Current	$I_{IH_DIM_CLK}$	$DIM_CLK = 5V$		45	70	μA
Input Low Current	$I_{IL_DIM_CLK}$	$DIM_CLK = 0V$		-65	-100	μA
TRI-STATE LOGIC INPUTS (DIM_MODE, DIV_248)						
Low State	V_{TL_TRI}		0.4	0.6		V
Floating State	V_{TF_TRI}		1.2	1.35	1.8	V
High State	V_{TH_TRI}			2.1	2.8	V
Input High Current	I_{IH_TRI}	$DIM_MODE = DIV_{248} = 5V$		70	120	μA
Input Low Current	I_{IL_TRI}	$DIM_MODE = DIV_{248} = 0V$		-25	-50	μA

ELECTRICAL CHARACTERISTICS (CONTINUED)

Parameter	Symbol	Test Conditions	LX1689			Units
			Min	Typ	Max	
ANALOG DIMMER BLOCK						
BRITE_IN Input Current	BRITE_IN _{II}	BRITE_IN = 0 to 5V	-1		1	μA
Conventional Dimming BRITE_OUT		BRITE_IN ≤ 0.45V	20	52	100	mV
		BRITE_IN ≥ 2.05V; T _A = 25°C	0.96	1.04	1.12	V
Reverse Dimming BRITE_OUT		BRITE_IN ≥ 2.05V	0.94	1.04	1.14	V
		BRITE_IN ≤ 0.45V; T _A = 25°C	0.98	1.06	1.14	V
		BRITE_IN ≤ 0.45V	0.96	1.06	1.16	V
		BRITE_IN ≥ 2.05V	10	62	120	mV
DIGITAL DIMMER BLOCK						
Conventional Dimming Duty Cycle		Minimum Duty Cycle; BRITE_IN ≤ 0.55V	2	10	15	%
		Maximum Duty Cycle; BRITE_IN = 1.90V	85	92	100	%
		Maximum Duty Cycle; BRITE_IN ≥ 1.95V	100			%
Reverse Dimming Duty Cycle		Maximum Duty Cycle; BRITE_IN ≤ 0.55V	100			%
		Maximum Duty Cycle; BRITE_IN = 0.6V	85	92	100	%
		Minimum Duty Cycle; BRITE_IN ≥ 1.95V	2	10	15	%
TIMING GENERATOR BLOCK						
Number of Lamp Return Current Cycles before Run Mode	N _{IGNITE}	To switch to Run Mode		8		Cycles
I_SNS Run Mode Checking Interval		Lamp return current cycles, 8192 x 1 / f _o		126		mS
Fault Comparator Threshold Voltage		I_SNS Open Lamp Fault Detect, T _A = 25°C	250	305	350	mV _{PK}
Number of Strike sweep Attempts Before Fault Shutdown	N _{STRK_FAULT}	FLAMP Sweep Cycles, I_SNS = 0V, V_SNS = 0V		15		
Power On Delay Before Strike	T _{D_PWRON}	16384 X Lamp Run Period		252		ms
Number of Sweeping Strike Frequency Steps per Attempt				1024		Steps
Number of Output Pulses per Striking Step				16		Cycles
LAMP FEEDBACK CONDITIONING BLOCK						
I_SNS Input Current	I_SNS _{IIN}	I_SNS = 10V		80	150	μA
		I_SNS = -10V		-200	-350	μA
OV_SNS Input High Threshold	V _{TH_OV_SNS}	Active Over Voltage Protection		± 2	± 2.2	V _{PK}
OV_SNS Input Low Threshold	V _{TL_OV_SNS}	Inactive Over Voltage Protection	± 1.8	± 2		V _{PK}
OV_SNS Input Current	OV_SNS _{IIN}	OV_SNS = 10V		260	400	μA
		OV_SNS = -10V		-320	-450	μA
OC_SNS Input High Threshold	V _{TH_OC_SNS}	Active Over Current Protection		± 2	± 2.2	V _{PK}
OC_SNS Input Low Threshold	V _{TL_OC_SNS}	Inactive Over Voltage Protection	± 1.8	± 2		V _{PK}
OC_SNS Input Current	OC_SNS _{IIN}	OC_SNS = 10V		45	80	μA
		OC_SNS = -10V		-110	-180	μA
Full Wave Rectifiers RMS Transfer	I_SNS _{RMS}	I_SNS = 0.3VDC, T _A = 25°C	0.27	0.31	0.35	V
		I_SNS = 2.0VDC, T _A = 25°C	1.95	2	2.05	V
		I_SNS = -0.3VDC, T _A = 25°C	0.24	0.3	0.36	V
		I_SNS = -2.0VDC, T _A = 25°C	1.75	1.9	2.05	V

BLOCK DIAGRAM

FIGURE 1 – Simplified Block Diagram

APPLICATION

FIGURE 3 – Typical Dual 4 Watt Application

DESCRIPTION**FEATURE REVIEW****On-Chip LDO Regulators**

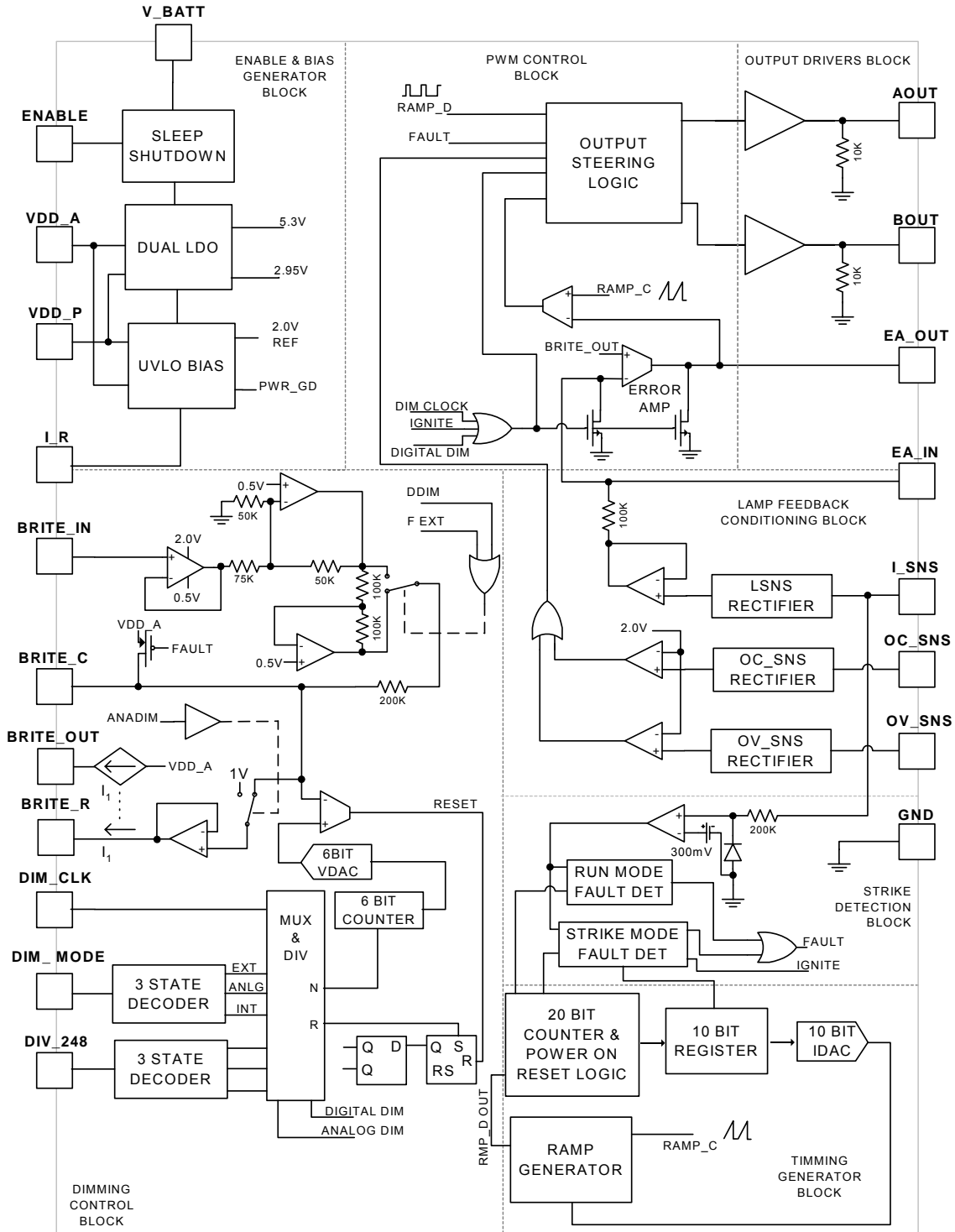
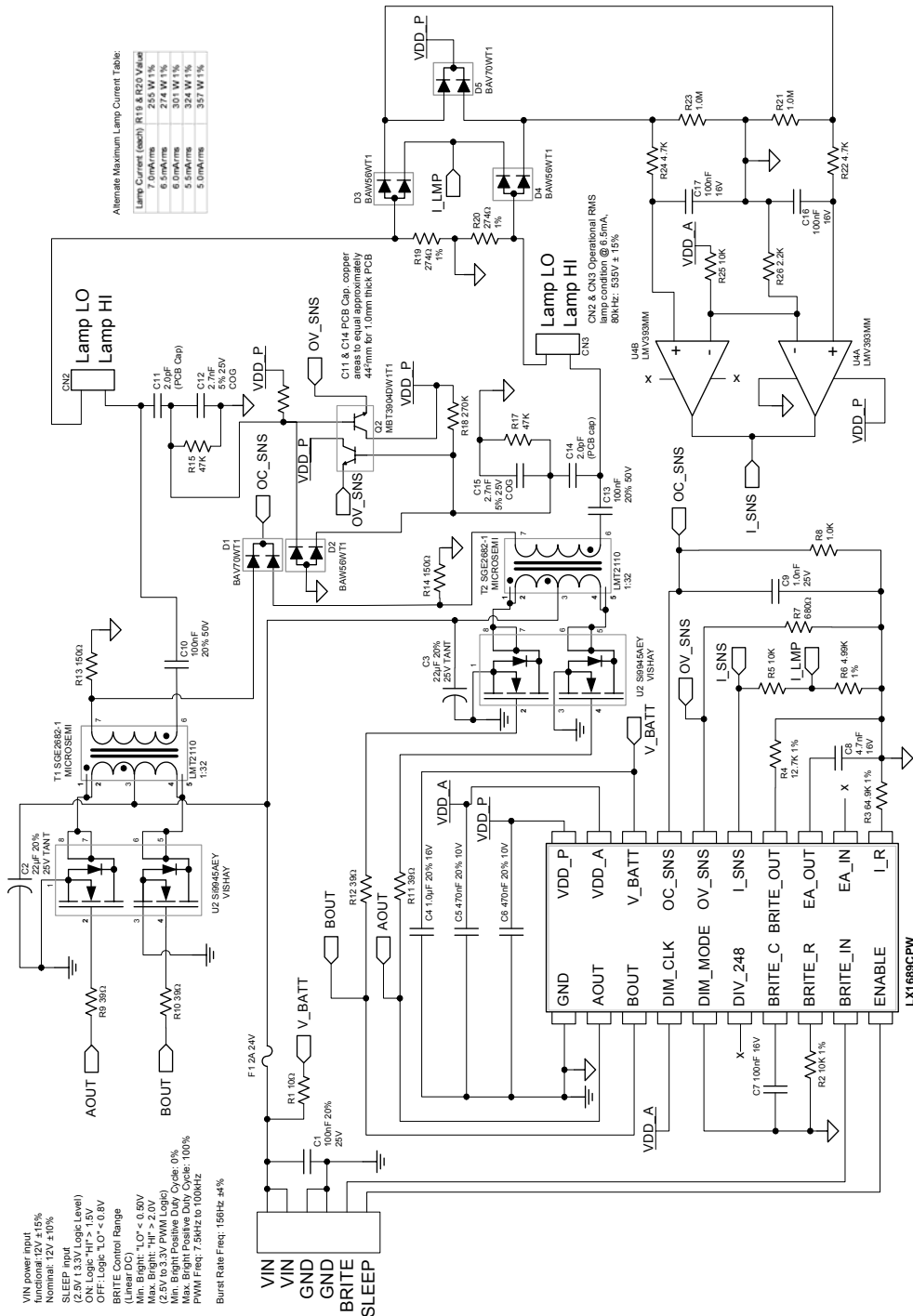
Two LDO regulators extend the input voltage range of the IC up to 28 Volts without using external circuitry as was required with our previous controllers.

Under Voltage Lockout

If the battery input voltage is too low for the controller to function properly, it will turn itself off, preventing spurious operation. If the battery voltage falls to less than 1V where UVLO is no longer guaranteed, 10K pull down resistors on the A_{OUT} and B_{OUT} pins insure the external power FETs cannot be biased on.

Power On Delay

A power up reset delays A_{OUT} and B_{OUT} turn on for approximately $16384 \times 1/f_o$ milliseconds after power is applied. This gives extra time for the BRITE_IN source voltage to stabilize so the lamp is not inadvertently powered up at high brightness and then suddenly lowered, creating an undesirable light flash.

Enhanced BRITE Conditioning Circuitry

The BRITE_IN input is now enhanced to accept either DC voltage or logic PWM signals. When PWM signals are input, their levels are clipped at 2V and 0.5V so lamp current will not be affected by variations in logic signal level. In addition, the BRITE_C pin permits filtering DC inputs and converting high frequency PWM inputs to DC voltages with the addition of only a single external capacitor. A low frequency (less than 500Hz) PWM signal can be used to directly modulate the duty cycle of the lamp current. In this case the capacitor at BRITE_C is not installed.

Digital or Analog Dimming Modes

A DIM_MODE input pin selects either Analog or Digital mode. In Analog mode DC voltage at BRITE_IN controls lamp current amplitude. In Digital mode it controls digital dimming duty cycle with amplitude fixed at a value set by the external current scaling resistor (BRITE_R). When in Digital mode, the dimming burst frequency can be synchronous to lamp current by selecting internal clocking, or to an external clock that may be a multiple of the video vertical frame rate. With an external clock source, three burst rate selections are available by programming the DIV_248 input to divide the source clock by 2,4, or 8. This clock source is further divided by 64 generating the internal burst ramp waveform. Using the internal clock as source the DIV_248 input changes to divide by 4, 8, or 16. This feature allows the designer to set a burst frequency in the range of 100 to 500Hz. The external clock source must not be interrupted unless the BRITE_IN is set $\geq 2V$ or the lamp will extinguish.

Brightness Polarity Control

In Analog dimming mode or internal Digital Dimming, the IC can be programmed to either increase or decrease lamp current amplitude as a function of increasing signal at the BRITE_IN pin by simply connecting the DIM_CLK input to ground or VDD_A or open(see Dimming Table). If External Digital dimming mode is used, lamp current amplitude is constant and its duty cycle is always directly proportional to DC input voltage and / or PWM duty cycle at the BRITE_IN pin.

Lamp Current Compensation

The BRITE_OUT pin outputs a precision current that is proportional to the BRITE_IN signal. This current can be applied to a precision resistor to develop the brightness control voltage at the error amplifiers non-inverting input. Since the output is constant current, designers can easily compensate lamp current with respect to temperature, input voltage, ambient or lamp light output, and combinations of these conditions by using various temperature or light sensitive components in combination with resistors. This capability is very useful in automotive and outdoor applications where operating temperatures and ambient light vary over wide ranges. See functional pin description for details.

Strike Voltage Generation

Improved strike voltage generation circuits ramp strike voltage to $5X f_o$ and repeats it's cycle unless excessive high voltage is sensed at OV_SNS. If OV_SNS is detected during strike, strike voltage will not ramp and will hold the current voltage until total strikes lamp cycles numbers reach 245,760. Strike potential is removed immediately when the lamp strikes or if the time limit is reached.

Strike Detection

The LX1689 includes a new lamp strike detection scheme that saves a package pin and three external components. Internal circuits monitor lamp current pulses at the I_SNS input to determine if the lamp strikes and if it stays ignited once operational.

Fault Time Out

If the lamp fails to ignite with in approximately 1.6 seconds (depending on Run Frequency) at maximum strike potential, or if it extinguishes while enabled, or the external clock frequency at the DIM_CLK pin terminates, the output drive is shut down and the BRITE_C pin is driven high. This pin can be monitored with a CMOS gate to obtain a logical indication that a lamp fault has occurred. It is especially useful in multiple lamp applications or for system diagnostic input.

The voltage on pin BRITE_C will vary directly with BRITE input voltage, but does not exceed 1.2V unless a fault condition occurs.

On Chip Rectifier

Integrating full wave rectifiers for each of three lamp inputs has significantly reduced lamp feedback component count. Current Sense (I_SNS), Over Current Sense (OC_SNS) and Over Voltage Sense (OV_SNS) signals are now detected using only one external scaling resistor or capacitor each. Rectification accuracy is improved with high performance on chip rectifiers to provide better lamp current and voltage regulation.

Complete Fault Protection

In addition to the faulty lamp time out, lamp open, lamp shorted, and either lamp terminal shorted to ground are detected. Open circuit voltage can never go higher than the preset maximum strike potential and total current from the circuit is safely limited with a scaling resistor. UL safety specifications can now be easily met in any application.

DESCRIPTION (CONTINUED)**LX1689 OPERATION**

Four operating modes: Power On Delay, Strike, Run, and Fault modes are employed by the LX1689. Upon power up or ENABLE going true, Power On Delay is automatically invoked. Immediately after termination of Power On Delay, or ENABLE going true, strike mode is entered. After a successful strike, e.g. lamp is ignited, run mode is entered. If ignition is unsuccessful, or if the lamp extinguishes while running, Fault mode is entered. Lamp ignition is determined by monitoring the lamp current feedback voltage at pin I_SNS. Lamp current cycles are counted from the beginning of Strike mode. If 8 or more complete cycles occur the lamp is declared ignited. If less than 8, the lamp is considered not ignited and Strike mode continues until ignition is detected or strike time out is reached.

After run mode is entered lamp current cycles are sampled every $8192 \times 1/f_o$ to determine that the lamp has not inadvertently extinguished. If at least 8 lamp current pulses are counted in each sample, Run mode is maintained. Otherwise, Fault mode is entered. Strike mode can be entered only once for each on/off cycle of either V_BATT or ENABLE. This insures that even intermittent lamp failures cannot cause the module to continuously output maximum strike voltage.

Power ON Delay Mode

All functions are activated except that AOUT and BOUT are inhibited. Delay is $16384 \times 1/f_o$ determined by counting Ramp clocks. The first of 16 sweeps is decoded as the power on delay period. The subsequent 15 sweeps are used for controlling the Ramp generator during Strike Mode. Power on delay is activated at every V_BATT power up sequence and ENABLE sequence.

Strike Mode

Entered from Power On Delay, or upon an ENABLE sequence. Control of the Ramp Generator frequency is switched to a DAC output. Frequency is increased in a saw tooth fashion from normal run value to as high as five times that value, for up to 15 sweeps. If while strike frequency is ramping up, the over voltage set point at OV_SNS is detected, strike frequency will freeze at that value until either the lamp strikes or the timeout is reached. Strike Mode is terminated by reaching 15 sweep counts or by detecting lamp ignition. If strike is successful, Run Mode is entered. If unsuccessful, Fault mode is entered, a fault is declared and the A & B outputs are shut off.

The purpose of sweeping lamp frequency up during strike is to operate at the unloaded resonant frequency of the transformer and lamp load. This generates the high lamp striking voltage required, since at resonance, output voltage from the transformer will increase to any value needed to cause ignition. A capacitive voltage divider provides output voltage feedback to the OV_SNS pin, which freezes Strike Frequency to limit maximum output voltage to a safe value.

Since strike frequency is held constant once the LX1689 senses maximum safe output voltage, maximum strike potential is continuously impressed across the lamp for the entire strike period.

Because strike frequency is ramped up rather than simply stepped, the entire range of possible self-resonant frequencies is covered. Transformer manufacturing is simplified and parasitic panel capacitance values are no longer critical. The 5:1 strike frequency range easily covers the self-resonant frequency of all practical lamp assembly and transformer combinations.

The only way to re-initiate the strike process is to either cycle V_BATT or ENABLE off and on.

If ignition is successful, ramp frequency immediately returns to its normal run value.

Run Mode

Entered only by detection of a successful Strike. Ramp generator frequency control is immediately switched from DAC output to a fixed reference that sets the normal run frequency. During Run mode, the Fault Detect Counter is reset approximately every $8192 \times 1/f_o$. The lamp current cycle counter is monitored to insure at least 8 current cycles received during each period. If less than 8, the lamp is considered extinguished and the Fault Mode is entered.

Fault Mode

Fault Mode may be entered from either Strike or Run Mode as described above. In Fault Mode, the A & B output drivers are forced low and the BRITE_C pin is driven to VDD_A to indicate the fault condition. Fault mode may be cleared by cycling ENABLE off then on, or by removing and applying V_BATT. External load on the BRITE_C pin is limited to a filter capacitor and single CMOS gate input.

DESIGN PROCEDURE**Selecting the I_R resistor value**

This resistor determines the frequency of the on chip oscillator. The output of the oscillator, RAMP_C, controls all timing functions. It must be chosen first, and will be in the range of 10K to 150K ohms. The output frequency approximated by the following formula: $R_{I_R} = 5.24E^9 / FLAMP_{OUT(Hz)}$

RAMP_C frequency is twice lamp output current frequency.

Driving the BRITE_IN Input

BRITE_IN can be a DC voltage, a low frequency PWM signal that produces direct digital dimming, or a higher frequency PWM signal that is converted to a proportional DC level by adding a filter capacitor at the BRITE_C pin. 100% duty cycle corresponds to 1.1 volt, and 0% duty cycle corresponds to zero volts at the BRITE_C pin. Maximum BRITE_IN input frequency for PWM inputs is 100 KHz, but when converting frequencies above 25 KHz to DC, some accuracy is lost. The BRITE_IN input circuitry includes on-chip active voltage clamps that ignore input voltage greater than 2.0V and less than 0.5V. This allows the use of digital PWM input signals where brightness is dependent only on duty cycle, with no contribution

DESCRIPTION (CONTINUED)

due to varying input signal amplitude. Input impedance is very high so BRITE_IN can also be driven from a 100K potentiometer with no offset error.

BRITE_R and BRITE_OUT Resistor values.

The BRITE_OUT pin is the output from the BRITE_IN signal processor. It is a linear current source that varies from 0 to the current value established at pin BRITE_R multiplied by the DC voltage at pin BRITE_C. The optimum value for BRITE_R is usually 10K ohms. The BRITE_OUT voltage range can be scaled from 300mV to 2.0V. However, it is recommended that the scaling of BRITE_OUT (including Analog mode BRITE_IN range) be within 400mV to 1.2V. Maximum voltage correlates to full brightness settings. It is the ratio of the two resistors multiplied by the voltage at BRITE_C:

$$V_{\text{BRITE_OUT}} = V_{\text{BRITE_C}} (R_{\text{BRITE_OUT}} / R_{\text{BRITE_R}})$$

In some applications, a precision 10K resistor is connected from BRITE_OUT and BRITE_R to ground to develop 1.0V to represent maximum lamp brightness. In Analog mode the BRITE_OUT voltage potential is proportional to BRITE_IN. The minimum brightness setting at BRITE_IN corresponds to the minimum voltage at BRITE_OUT. In digital mode, BRITE_IN has no effect on BRITE_OUT.

Because the BRITE_OUT output is a linear current source, you can place other components, such as a thermistor or photo resistor, at this pin to generate complex functions for controlling brightness. For example; use a PWM input at the BRITE_IN pin to control dimming, and boost analog lamp current amplitude at cold lamp temperature with a thermistor at the BRITE_OUT pin. This will help warm the lamp faster at start up so final brightness is reached sooner.

SETTING THE OUTPUT CURRENT.

Referring to the application examples figures 2 and 3. The current setting resistor(s) are R7, and R19 and R20 respectively. The value these resistor(s) are in the range of 200 to 400ohms. The following formula can be used to determine the current setting resistor value. Use 1180 for Digital mode and 1260 for analog dim.

$$R_{\text{SNS}} = 1180 \text{ or } 1260 \times R_{\text{BRITE_OUT}} / I_{\text{OUT}}(\text{mA}_{\text{RMS}}) \times R_{\text{BRITE_R}}$$

In the 1W burst dimming application example shown in figure 2 the output current is set for nominally 3.5mA. RSNS is calculated using the formula above as follows:

$$R_{\text{SNS}} = 1180 \times 4990 / 3.5 \times 6550 = 256.8 \text{ ohms}$$

A standard value of 255 ohms was chosen. It is recommended to keep the value of the sense resistor in the range of 200 to 400 ohms as stated above. If calculated value exceeds 400 ohms its best to increase the value of the R_{BRITE_R} resistor.

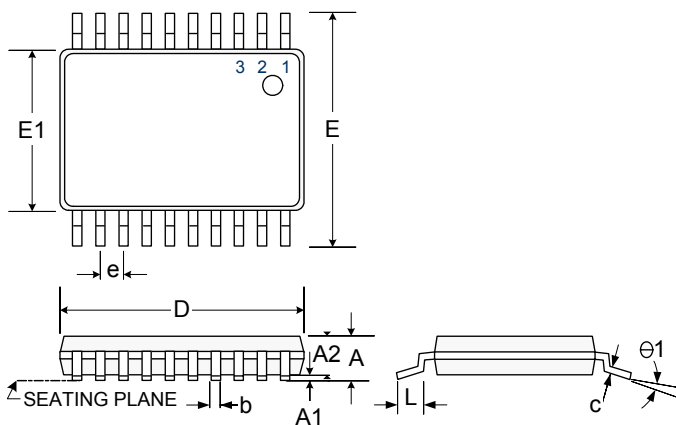
MECHANICAL DRAWING
PW 20-Pin Thin Small Shrink Outline (TSSOP)

Dim	MILLIMETERS		INCHES	
	MIN	MAX	MIN	MAX
A	-	1.10	-	0.043
A1	0.05	0.15	0.002	0.006
A2	0.80	1.05	0.031	0.041
b	0.19	0.30	0.007	0.012
c	0.09	0.20	0.004	0.008
D	6.40	6.60	0.252	0.260
E	6.25	6.55	0.246	0.258
E1	4.30	4.50	0.169	0.177
e	0.65 BSC		0.026 BSC	
L	0.45	0.75	0.018	0.030
theta1	0°	8°	0°	8°
*LC	-	0.10	-	0.004

* Lead Coplanarity

Note:

1. Dimensions do not include mold flash or protrusions; these shall not exceed 0.155mm(.006") on any side. Lead dimension shall not include solder coverage.



LX1689

Third Generation CCFL Controller

PRODUCTION DATA SHEET

NOTES

PRODUCTION DATA – Information contained in this document is proprietary to Microsemi and is current as of publication date. This document may not be modified in any way without the express written consent of Microsemi. Product processing does not necessarily include testing of all parameters. Microsemi reserves the right to change the configuration and performance of the product and to discontinue product at any time.