

ADVANCED



ISD18B12

**SINGLE-CHIP, SINGLE-MESSAGE
VOICE RECORD/PLAYBACK DEVICE
6- TO 12-SECONDS DURATION**

Advanced



TABLE OF CONTENTS

1. GENERAL DESCRIPTION.....	3
2. FEATURES.....	3
3. BLOCK DIAGRAM.....	4
4. PAD DESCRIPTION.....	5
5. FUNCTIONAL DESCRIPTION.....	6
6. ABSOLUTE MAXIMUM RATINGS	11
6.1 Operating Conditions.....	11
7. ELECTRICAL CHARACTERISTICS.....	12
7.1. DC Parameters	12
7.2. AC Parameters	13
8. TYPICAL APPLICATION CIRCUIT	14
9. DIE INFORMATION.....	16
10. ORDERING INFORMATION.....	17
11. VERSION HISTORY.....	18

Advanced



1. GENERAL DESCRIPTION

Winbond's ISD18B12 ChipCorder[®] is a new single-chip single-message record/playback device with a special TryMe feature. The user-selectable duration is from 6 to 12 seconds, with wide operating voltage ranging from 2.4V to 5.5V. Its sampling frequency, ranging from 4kHz to 8kHz, is externally controlled via resistor at Rosc pin. This device also includes microphone amplifier, anti-aliasing filter, multilevel storage array, smoothing filter and speaker amplifier. Two external resistors are used to adjust the microphone amplifier gain for the incoming signal. Thus, a minimum record/playback subsystem can be configured with a microphone, a speaker, several passive components, two push buttons, and a power source.

Recordings are stored into on-chip non-volatile memory, providing zero-power message storage. This unique, single-chip solution is made possible through Winbond's patented Multi-Level Storage technology. Voice and audio signals are stored directly into memory in their natural form, providing high-quality, solid-state voice reproduction. The device is automatically power down after each operation cycle with typical standby current, 1 μ A. With the embedded Flash memory employed, data retention up to 100 years and typical 100,000 erase/record cycles can be reached.

2. FEATURES

- Supply voltage: 2.4V to 5.5V
- User-selected variable sampling frequency and duration via external resistor

Sampling Frequency	8 kHz	6.4 kHz	5.3 kHz	4 kHz
Rosc	80 K Ω	100 K Ω	120 K Ω	160 K Ω
Duration	6 secs	7.5 secs	9 secs	12 secs

- $\overline{\text{RECL}}$: Level recording
- $\overline{\text{RECE}}$: Edge-trigger, toggle on-off
- $\overline{\text{PLAYE}}$: Edge-trigger, toggle on-off
- $\overline{\text{PLAYL}}$: Level playback or looping playback
- $\overline{\text{LEDR}}$: LED output for recording
- $\overline{\text{LEDP}}$: LED output for playback
- $\overline{\text{FT}}$: Feed-through microphone input to speaker outputs
- Microphone amplifier gain: user control via two external resistors
- With feed-through enabled, record microphone signal into memory while feed-through path remains active
- Playback takes precedence over the Recording operation
- **TryMe** : TryMe special mode
- Package option: die only
- Temperature options: 0°C to +50°C



3. BLOCK DIAGRAM

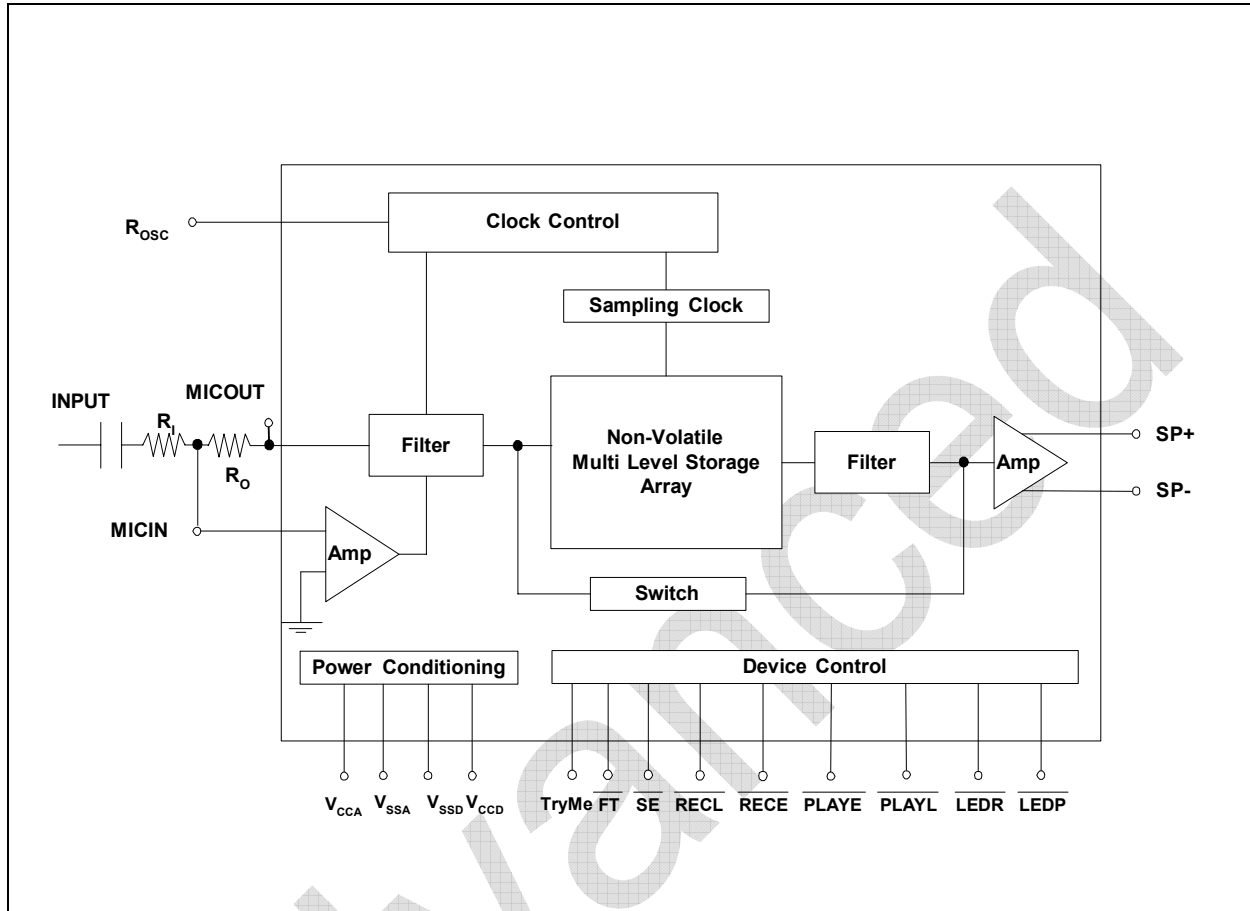



4. PAD DESCRIPTION

PAD NAME	I / O	FUNCTION
V _{SSD}	I	Digital Ground: Ground path for digital circuits.
$\overline{\text{RECL}}$	I	Level-Triggered Record: Low active input, Level-hold.
$\overline{\text{PLAYE}}$	I	Edge-Triggered Playback: Low active input, Edge-trigger, toggle on-off.
$\overline{\text{PLAYL}}$	I	Level-Triggered Playback: Low active input, Level-hold.
$\overline{\text{RECE}}$	I	Edge-Triggered Record: Low active input, Edge-trigger, toggle on-off.
NC	--	NC: No Connect
NC	--	NC: No Connect
NC	--	NC: No Connect
NC	--	NC: No Connect
MICIN	I	Microphone Input: The MICIN transfers input signal to the on-chip microphone amplifier.
NC	--	NC: No Connect
MICOUT	O	Microphone Output: Output of the microphone amplifier.
NC	--	NC: No Connect
NC	--	NC: No Connect
SP-	O	SP-: The negative signal of the differential speaker outputs.
V _{SSA}	I	Analog Ground: Ground path for analog circuits.
SP+	O	SP+: The positive signal of the differential speaker outputs.
V _{CCA}	I	Power Supply: Power supply for analog circuits.
Rosc	I	Oscillator Resistor: Connect an external resistor from this pin to V _{SSA} to select the sampling frequency
$\overline{\text{FT}}$	I	Feed-Through (FT): Low active input, Level-hold, Feed-through microphone input to speaker outputs while in active state.
NC	--	NC: No Connect
NC	--	NC: No Connect
TryMe	I	TryMe Mode : High active input, Level-hold. A special operating mode.
$\overline{\text{LEDP}}$	O	LED output for Playback: During playback, this output is Low.
NC	--	NC: No Connect
$\overline{\text{SE}}$	I	Sound Effect: Low active input, Level-hold, optional beeping sound effect.
V _{CCD}	I	Power Supply: Power supply for digital circuits.
$\overline{\text{LEDR}}$	O	LED output for Recording: During recording, this output is Low.



5. FUNCTIONAL DESCRIPTION

For the following related operations, if SE is not enabled, then no beep sound is heard. Also, the timing diagrams may not be in direct proportional scale.

5.1. Level-triggered Record ($\overline{\text{RECL}}$) Operation :

- Recording starts from beginning of the memory and $\overline{\text{LEDR}}$ is on.
- Recording ceases whenever $\overline{\text{RECL}}$ returns to High or when end of memory is reached and $\overline{\text{LEDR}}$ is off.
- Then device will automatically power down.

Fig. 1: Record-Level ($\overline{\text{RECL}}$) function till memory full

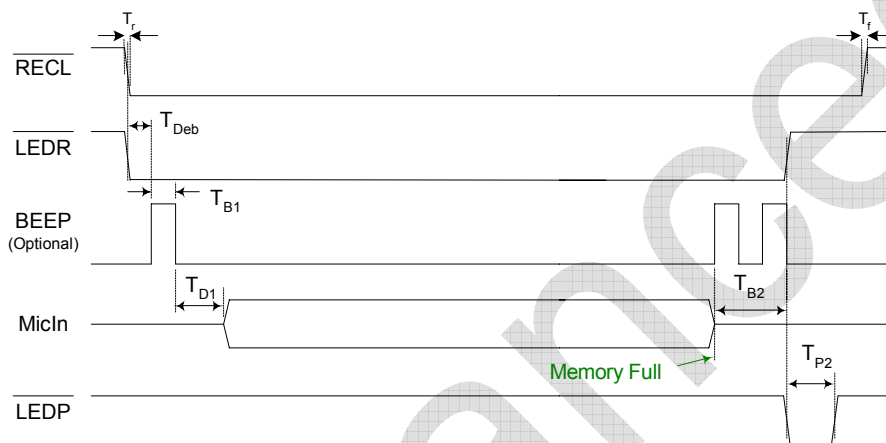

5.2. Edge-triggered Record ($\overline{\text{RECE}}$) Operation :

- Recording starts from beginning of the memory and $\overline{\text{LEDR}}$ is on.
- Recording ceases whenever a subsequent trigger occurs at $\overline{\text{RECE}}$ or when end of memory is reached and $\overline{\text{LEDR}}$ is off.
- Then device will automatically power down.

Fig. 2: Record-Edge ($\overline{\text{RECE}}$) function with on-off

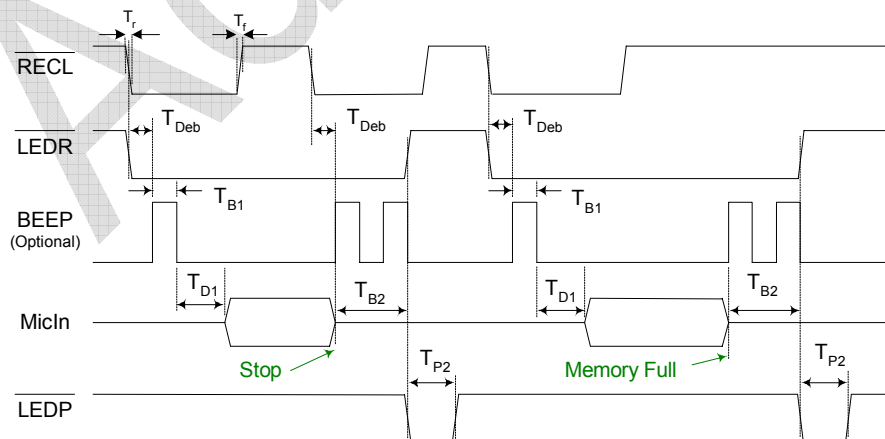



5.3. Edge-triggered playback ($\overline{\text{PLAYE}}$) Operation :

- Playback starts from beginning of the memory and $\overline{\text{LEDP}}$ is on.
- Playback stops whenever end of message or a subsequent trigger occurs and $\overline{\text{LEDP}}$ is off.
- Then device will automatically power down.

Fig. 3 : Playback–Edge ($\overline{\text{PLAYE}}$) function

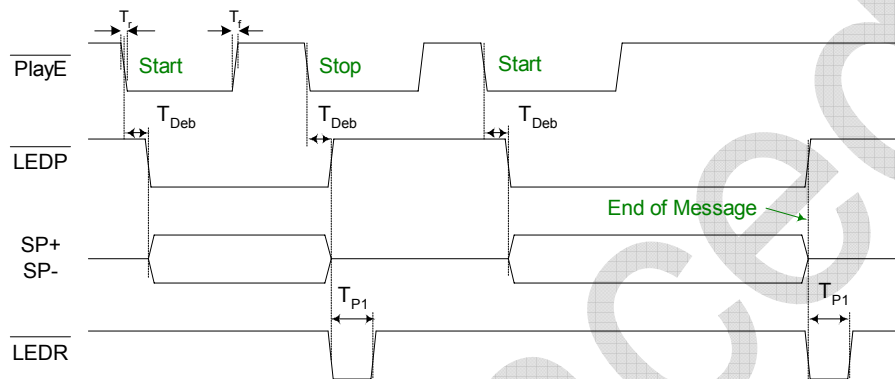

5.4. Level- triggered playback ($\overline{\text{PLAYL}}$) Operation :

- Playback starts from beginning of the memory and $\overline{\text{LEDP}}$ is on.
- Playback stops whenever an EOM marker is reached or $\overline{\text{PLAYL}}$ returns to High and $\overline{\text{LEDP}}$ is off.
- Then device will automatically power down.

Fig. 4: Playback–Level ($\overline{\text{PLAYL}}$) function

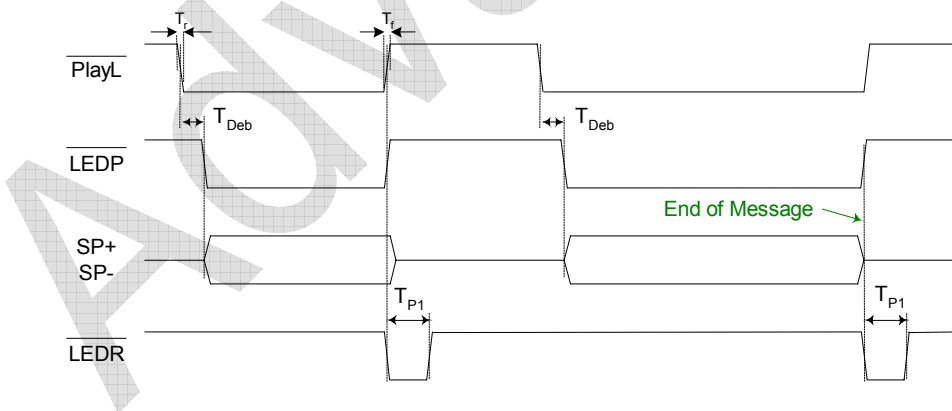

- Holding $\overline{\text{PLAYL}}$ Low constantly will perform looping playback function.

Fig. 5: Looping playback function via $\overline{\text{PLAYL}}$

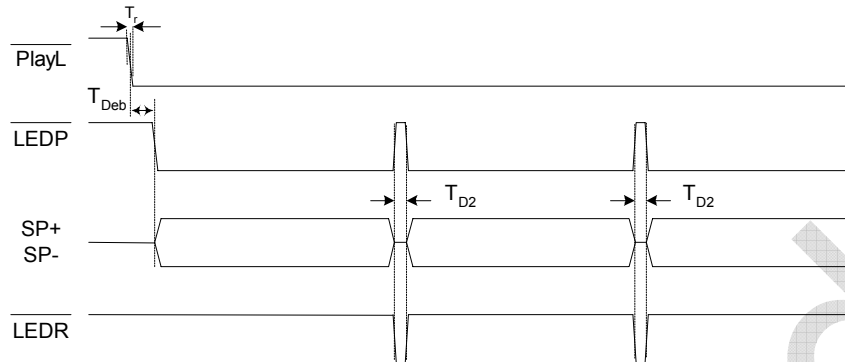

5.5. Sound Effect (\overline{SE}) Operation :

- Beeping feature for recording. Once active, one-beep indicates the start of recording and two-beep represents the end of recording.

5.6. Microphone amplifier gain

- Two external resistors, R_I and R_O , are used to adjust the microphone amplifier gain with respect to the incoming signal.

5.7. Playback (supersedes Record) Operation :

- Playback takes precedence over the Recording operation.
- If either \overline{PLAYE} or \overline{PLAYL} is activated during a recording cycle, the recording immediately ceases and playback of the just-recorded message performs accordingly.

5.8. Feed-Through mode Operation :

- As \overline{FT} is held Low, the input signal from MICIN will directly transmit to the speaker outputs.
- If either \overline{RECE} is triggered or \overline{RECL} is held Low simultaneously after \overline{FT} is enabled, then input signal will be recorded into memory while the Feed-Through mode is still on.
- After \overline{FT} is enabled, activating either \overline{PLAYE} or \overline{PLAYL} will first disable the feed-through path and play the recorded message. Once playback is completed, the feed-through feature resumes.

5.9. \overline{LEDR} Operation :

- \overline{LEDR} stays on during recording.
- Also, \overline{LEDR} pulses Low momentarily at the end of playback operation.

5.10. \overline{LEDP} Operation :

- \overline{LEDP} stays on during playback.
- Also, \overline{LEDP} pulses Low momentarily at the end of recording.

5.11. Rosc Operation :

- When the R_{OSC} varies from 80 K Ω to 160 K Ω , the duration changes from 6 to 12 seconds accordingly.
- When R_{OSC} resistor value is changed during playback, the tone of a recorded message will alter either faster or slower.

5.12. Speaker Outputs

- Both $SP+$ and $SP-$ outputs can be used to drive an 8 Ω speaker differentially. They are tri-state while device is in power down status.



5.13. TryMe Special Operation :

This is a special feature. When **TryMe** is High, TryMe is active. When **TryMe** is Low, TryMe is disabled. The enabling and disabling of this feature is merely permitted while the device is in power down status. Once **TryMe** is set, trigger on either $\overline{\text{RECL}}$ or $\overline{\text{RECE}}$ will initiate the TryMe operation sequence. While active, the device performs a combination of the following 3 operations sequentially: Record a new message and automatic playback the just-recorded message once, then delete the recorded message. Internal pull-up exists.

The details of each operation are described as follows:

- a) Recording:
 - The recording behavior follows the characteristics of the selected record pin, $\overline{\text{RECL}}$ or $\overline{\text{RECE}}$.
 - While recording, the $\overline{\text{LEDR}}$ is on if an LED is connected appropriately.
- b) Playback:
 - Upon completion of recording, the device automatic plays the just-recorded message once and stops. During this operation, change of state on any control pins is prohibited.
 - While playback, the $\overline{\text{LEDP}}$ is on if an LED is connected appropriately.
- c) Erasure:
 - Upon completion of playback, the device will involuntary delete the recorded message. During this operation, change of state on any control pins is banned.

After completion of this TryMe operation, the device returns to standby state automatically. Once playback operation starts, any input on other controls is illegal.

As a summary, the TryMe mode starts in the following conditions:

Pin	TryMe	$\overline{\text{RECL}}$	$\overline{\text{RECE}}$
Logic Level	1	0	1
	1	1	0

Under no circumstances, while this special operation is in progress, neither the power is disturbed nor any change of state on other control pins are permitted. Otherwise, it may cause the device becoming malfunction.

Fig 6: TryMe function via (TryMe + $\overline{\text{RECL}}$)

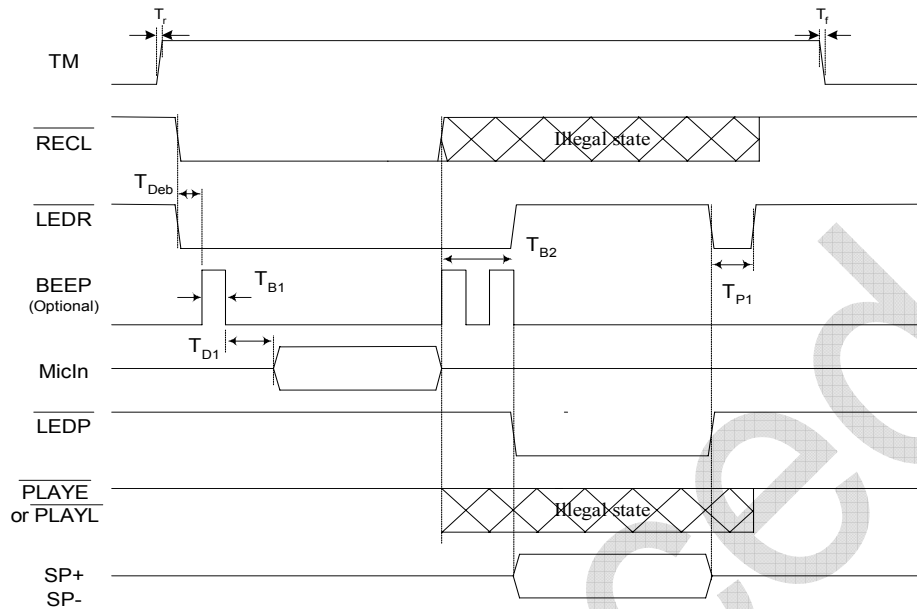

5.14. Power interruption

- Any power interruption during an operation is **strongly** not recommended. If happened, it may result the device becoming malfunction.

5.15. Power-On to Playback Operation :

- If $\overline{\text{PLAYE}}$ or $\overline{\text{PLAYL}}$ is held at Low during power turns on, the device plays message accordingly with respect to which play control being employed.

5.16. Power-On to Loop Playback Operation :

- If $\overline{\text{PLAYL}}$ is hardwired to ground permanently, once power is on, the device performs looping playback non-stop. This status will sustain unless power is turned off.

5.17. Automatic Playback after Record Operation :

- If $\overline{\text{LEDP}}$ is connected to $\overline{\text{PLAYE}}$, after a record operation, then the device will automatic play message once, then powers down.



6. ABSOLUTE MAXIMUM RATINGS

ABSOLUTE MAXIMUM RATINGS ^[1]

CONDITION	VALUE
Junction temperature	150°C
Storage temperature range	-65°C to +150°C
Voltage applied to any pins	(V _{SS} - 0.3V) to (V _{CC} + 0.3V)
Voltage applied to Input pins (current limited to +/-20 mA)	(V _{SS} - 1.0V) to (V _{CC} + 1.0V)
Voltage applied to output pins (current limited to +/-20 mA)	(V _{SS} - 1.0V) to (V _{CC} + 1.0V)
V _{CC} - V _{SS}	-0.3V to +7.0V

^[1] Stresses above those listed may cause permanent damage to the device. Exposure to the absolute maximum ratings may affect device reliability and performance. Functional operation is not implied at these conditions.

6.1 OPERATING CONDITIONS

OPERATING CONDITIONS

CONDITION	VALUE
Operating temperature range	0°C to +50°C
Operating voltage (V _{CC}) ^[1]	+2.4V to +5.5V
Ground voltage (V _{SS}) ^[2]	0V

^[1] V_{CC} = V_{CCA} = V_{CCD}

^[2] V_{SS} = V_{SSA} = V_{SSD}



7. ELECTRICAL CHARACTERISTICS

7.1. DC PARAMETERS

PARAMETER	SYMBOL	MIN ^[2]	TYP ^[1]	MAX ^[2]	UNITS	CONDITIONS
Input Low Voltage	V _{IL}			0.3xV _{CC}	V	
Input High Voltage	V _{IH}	0.7xV _{CC}			V	
Output Low Voltage	V _{OL}			0.3xV _{CC}	V	I _{OL} = 4.0 mA ^[3]
Output High Voltage	V _{OH}	0.7xV _{CC}			V	I _{OH} = -1.6 mA ^[3]
Standby Current	I _{STBY}		1	10	μA	^[4] ^[5]
Record Current	I _{REC}			15	mA	V _{CC} = 5.5V
Playback Current	I _{PLAY}			15	mA	V _{CC} = 5.5V, no speaker load
Pull-up device for $\overline{\text{RECL}}$, $\overline{\text{RECE}}$, $\overline{\text{PLAYE}}$, $\overline{\text{PLAYL}}$, $\overline{\text{FT}}$ & TryMe pins	R _{PU1}		40		kΩ	
Pull-up device for $\overline{\text{SE}}$	R _{PU2}		80		kΩ	
Output Load Impedance	R _{EXT}	8			Ω	Speaker load
MIC Input Voltage	V _{IN}	4		400	mV	Peak-to-peak
MIC Amplifier Gain	A _{MicAmp}	0		+34	dB	Depend on RO/RI
Gain from MIC to SP+/SP-	A _{MSP}	+12		+46	dB	Depend on RO/RI

Notes:

- ^[1] Typical values @ T_A = 25°, V_{CC} = 5.5V and sampling frequency (Fs) at 8 kHz, unless stated.
- ^[2] All Min/Max limits are guaranteed by design, electrical testing and/or characterization. Not all specifications are 100 percent tested.
- ^[3] LED output during recording.
- ^[4] V_{CCA} and V_{CCD} are connected together. Also, V_{SSA} and V_{SSD} are connected together.
- ^[5] $\overline{\text{RECL}}$, $\overline{\text{RECE}}$, $\overline{\text{PLAYE}}$, $\overline{\text{PLAYL}}$, $\overline{\text{SE}}$, $\overline{\text{FT}}$ and **TryMe** must be at V_{CCD}. External components are biased under a separated power supply.



7.2. AC PARAMETERS

CHARACTERISTIC	SYMBOL	MIN ^[2]	TYP ^[1]	MAX ^[2]	UNITS	CONDITIONS
Sampling Frequency	F _S	4		8	kHz	[3]
Record Duration	T _{REC}	6		12	sec	Depend on F _S [3]
Playback Duration	T _{PLAY}	6		12	sec	Depend on F _S [3]
Rising Time	T _r		100		nsec	[3]
Falling Time	T _f		100		nsec	[3]
Debounce Time	T _{Deb}	536k/FS			msec	[3] [4]
Beep Duration	T _{B1}		512k/FS		msec	[3] [4]
Beep-Beep Duration	T _{B2}		1536k/FS		msec	[3] [4]
Delay to start recording	T _{D1}		1552k/FS		msec	[3] [4]
Delay during looping	T _{D2}		1k/FS		msec	[3] [4]
LEDR Pulse Low Time	T _{P1}		1024k/FS		msec	[3] [4]
LEDP Pulse Low Time	T _{P2}		1280k/FS		msec	[3] [4]

Notes:

- [1] Conditions are V_{CC} = 5.5V and T_A = 25°C, unless specified.
- [2] All Min/Max limits are guaranteed by design, electrical testing and/or characterization. Not all specifications are 100 percent tested.
- [3] The value changes accordingly to the F_S applied. Also, the internal oscillator may vary as much as ±10% over the operating temperature and voltage ranges.
- [4] k=1000



8. TYPICAL APPLICATION CIRCUIT

The following typical application examples on ISD18B12 series are for references only. They make no representation or warranty that such applications shall be suitable for the use specified. Each design has to be optimized in its own system for the best performance on voice quality, current consumption, functionalities and etc. It's customer's obligation to confirm the design on all the functionalities of their end-products.

In addition, the below notes apply to the following application examples:

- * The suggested values are for references only. Depending on system requirements, they must be fine tuned for best performance.

It is important to have a separate path for each ground and power back to the related terminals to minimize the noise. Besides, the power supplies should be decoupled as close to the device as possible.

Also, it is crucial to follow good audio design practices in layout and power supply decoupling. See recommendations in Application Notes from our websites.

Example #1: Typical Recording and Playback operations

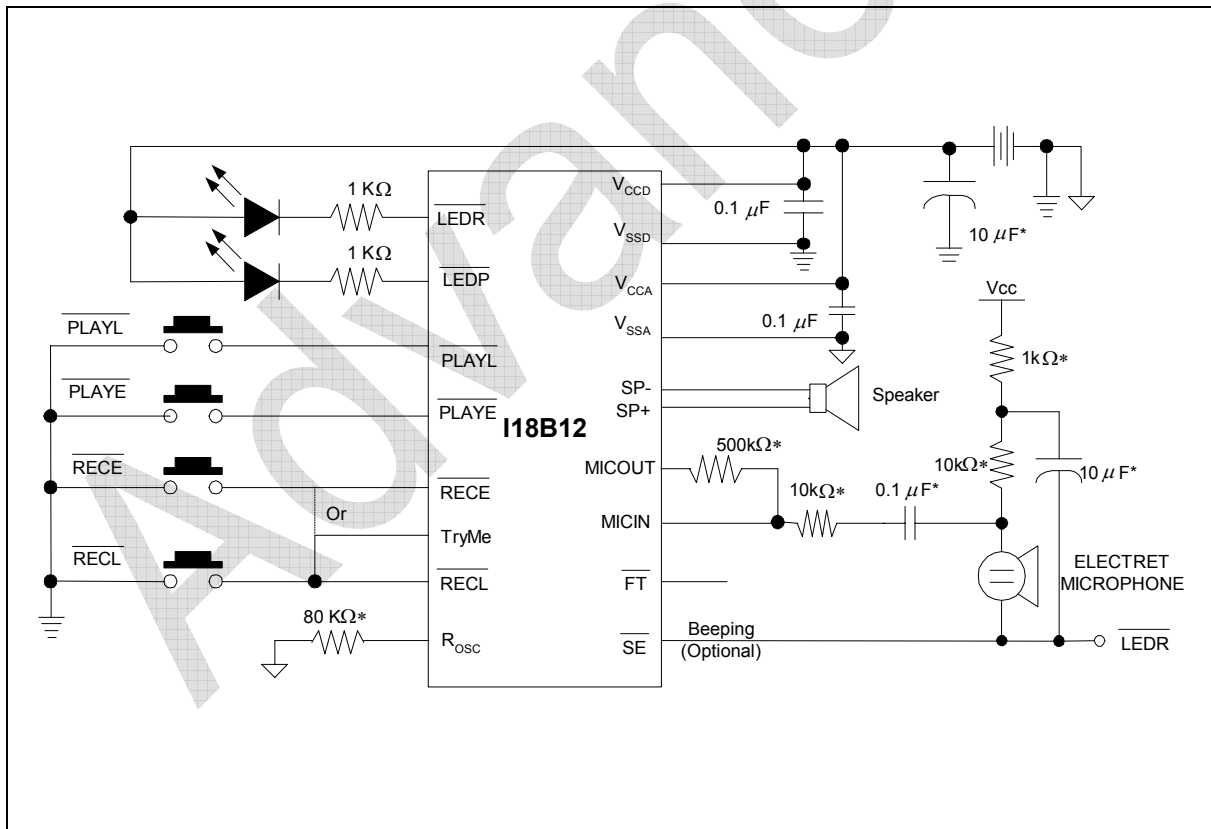

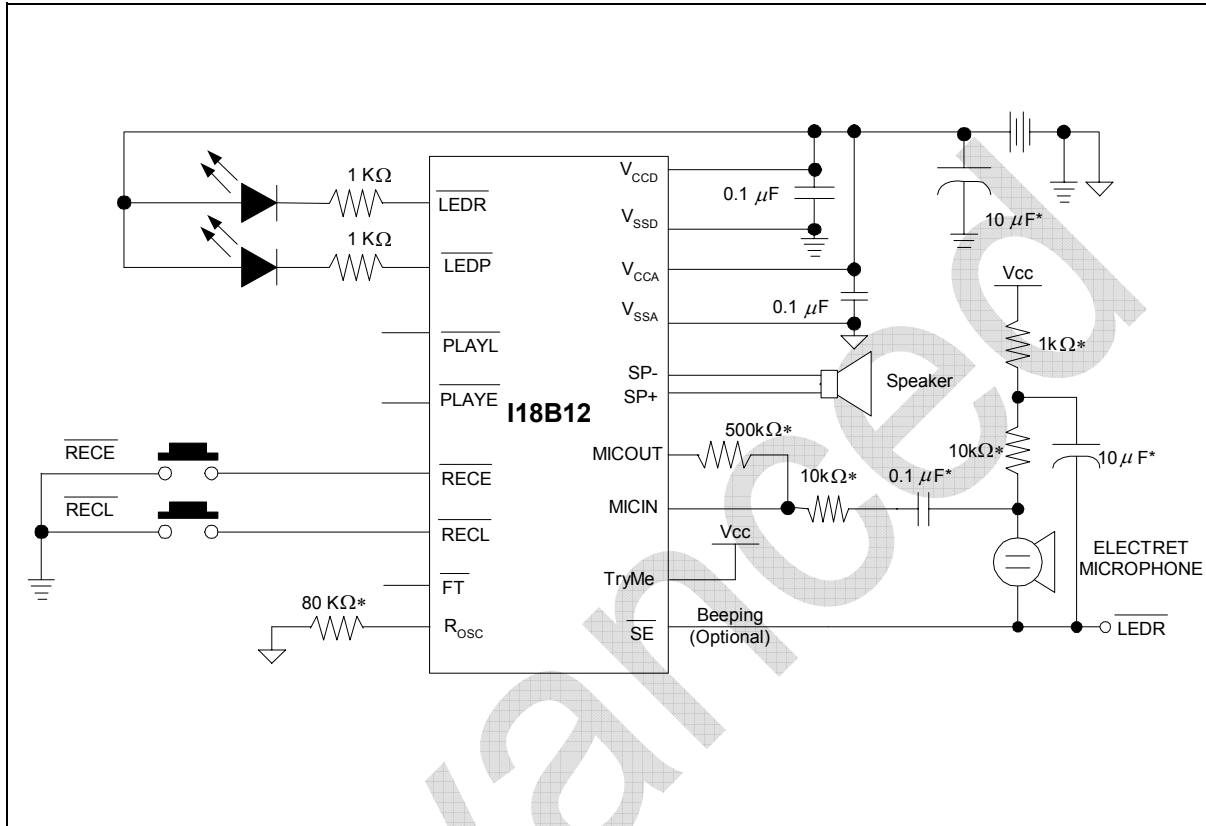

Example #2: TryMe feature

**Good Audio Design Practices**

Winbond's ChipCorder are very high-quality single-chip voice recording and playback devices. To ensure the highest quality voice reproduction, it is important that good audio design practices on layout and power supply decoupling are followed. See Application Information links below for details.

Good Audio Design Practices

http://www.winbond-usa.com/products/isd_products/chipcorder/applicationinfo/apin11.pdf

Single-Chip Board Layout Diagrams

http://www.winbond-usa.com/products/isd_products/chipcorder/applicationinfo/apin12.pdf

It is strongly recommended that before any design or layout project starts, the designer should contact Winbond Sales Rep for the most update technical information.



9. DIE INFORMATION

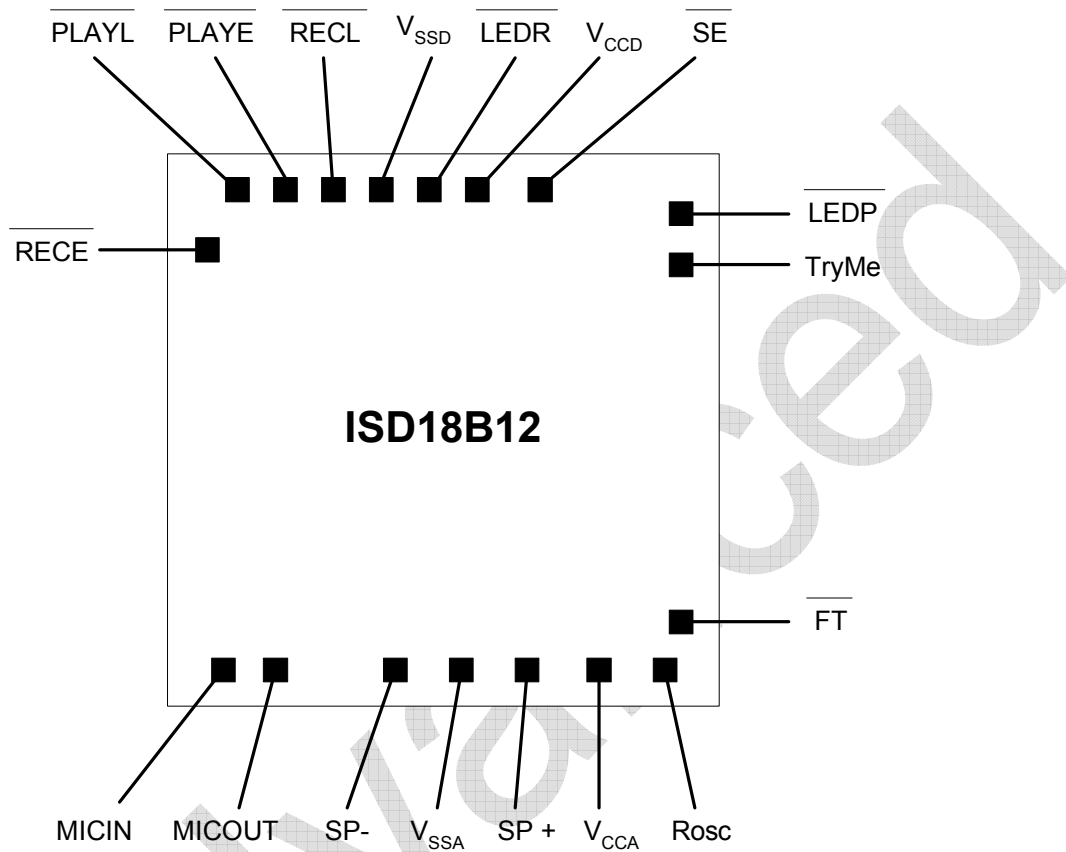

Contact Winbond Sales Representatives for information.



10. ORDERING INFORMATION

Product Number Descriptor Key

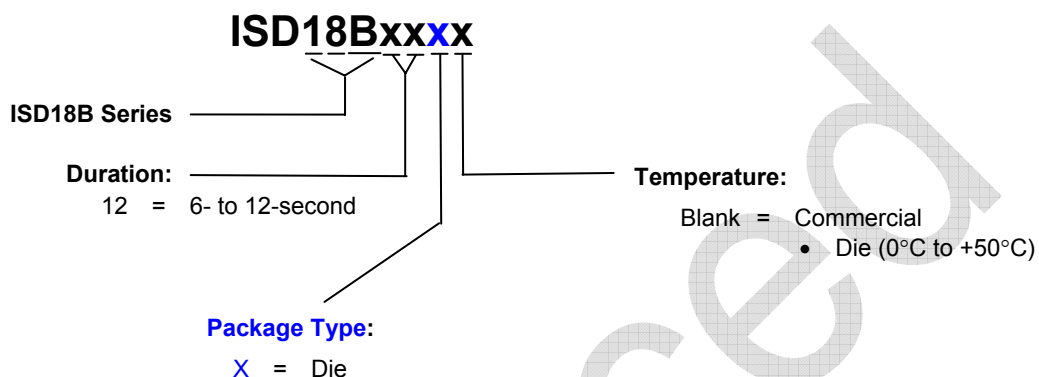

When ordering, please refer to the following part numbers that are supported in volume for this product series. Consult the local Winbond Sales Representative or Distributor for availability information.

Package	Part Number	Ordering Number	Comments
Die	ISD18B12X	I18B12X	

For the latest product information, access Winbond's worldwide website at <http://www.winbond-usa.com>

**11. VERSION HISTORY**

VERSION	DATE	DESCRIPTION
A0	May 2007	Pre-released version
A1	August 2007	Initial revision

Advanced



Winbond products are not designed, intended, authorized or warranted for use as components in systems or equipment intended for surgical implantation, atomic energy control instruments, airplane or spaceship instruments, transportation instruments, traffic signal instruments, combustion control instruments, or for other applications intended to support or sustain life. Furthermore, Winbond products are not intended for applications wherein failure of Winbond products could result or lead to a situation wherein personal injury, death or severe property or environmental damage could occur.

Winbond customers using or selling these products for use in such applications do so at their own risk and agree to fully indemnify Winbond for any damages resulting from such improper use or sales.

The contents of this document are provided only as a guide for the applications of Winbond products. Winbond makes no representation or warranties with respect to the accuracy or completeness of the contents of this publication and reserves the right to discontinue or make changes to specifications and product descriptions at any time without notice. No license, whether express or implied, to any intellectual property or other right of Winbond or others is granted by this publication. Except as set forth in Winbond's Standard Terms and Conditions of Sale, Winbond assumes no liability whatsoever and disclaims any express or implied warranty of merchantability, fitness for a particular purpose or infringement of any Intellectual property.

The contents of this document are provided "AS IS", and Winbond assumes no liability whatsoever and disclaims any express or implied warranty of merchantability, fitness for a particular purpose or infringement of any Intellectual property. In no event, shall Winbond be liable for any damages whatsoever (including, without limitation, damages for loss of profits, business interruption, loss of information) arising out of the use of or inability to use the contents of this documents, even if Winbond has been advised of the possibility of such damages.

Application examples and alternative uses of any integrated circuit contained in this publication are for illustration only and Winbond makes no representation or warranty that such applications shall be suitable for the use specified.

The 100-year retention and 100K record cycle projections are based upon accelerated reliability tests, as published in the Winbond Reliability Report, and are neither warranted nor guaranteed by Winbond. This product incorporates SuperFlash®.

Information contained in this ISD® ChipCorder® datasheet supersedes all data for the ISD ChipCorder products published by ISD® prior to August, 1998.

This datasheet and any future addendum to this datasheet is(are) the complete and controlling ISD® ChipCorder® product specifications. In the event any inconsistencies exist between the information in this and other product documentation, or in the event that other product documentation contains information in addition to the information in this, the information contained herein supersedes and governs such other information in its entirety. This datasheet is subject to change without notice.

Copyright® 2005, Winbond Electronics Corporation. All rights reserved. ChipCorder® and ISD® are trademarks of Winbond Electronics Corporation. SuperFlash® is the trademark of Silicon Storage Technology, Inc. All other trademarks are properties of their respective owners.