

Ultra Low Power 10.3 Gbps 2-Channel Repeaters with Input Equalization and Output De-Emphasis

General Description

The DS100BR210 and DS100BR111 are extremely low power, high performance dual-channel repeaters for serial links with data rates up to 10.3 Gbps. The DS100BR210 features two unidirectional channels, while the DS100BR111 features one bidirectional lane (one transmit, one receive channel).

Both devices feature a powerful 4-stage continuous time linear equalizer (CTLE) to open an input eye that is completely closed due to inter-symbol interference (ISI) induced by the interconnect mediums. The transmitter features a programmable output de-emphasis driver and allows amplitude voltage levels to be selected from 700 mVp-p to 1200 mVp-p to suit multiple application scenarios.

DS100BR210/111 consume 65 mW/channel (typ), and allow the option to turn-off unused channels. This ultra low power consumption eliminates the need for external heat sinks and simplifies thermal management in active cable applications.

The programmable settings can be applied via pin settings, SMBus (I2C) protocol. Offered in a small 4mm x 4mm LLP package with flow through pinout, the DS100BR210/111 are easy to design.

Notice: This document is not a full datasheet. For more information regarding this product or to order samples please contact your local National Semiconductor sales office or visit <http://www.national.com/support/dir.html>

Features

- Two channel repeater for up to 10.3 Gbps
 - DS100BR210 : 2x unidirectional channels
 - DS100BR111 : 1x bidirectional lane
- Low 65mW/channel (typ) power consumption, with option to power down unused channels
- Advanced signal conditioning features
 - Advanced 4-Stage Equalization
 - Transmit de-emphasis
 - Transmit VOD control: 700 to 1200 mVp-p
 - < 0.3 UI of residual DJ at 10 Gbps with 50" FR-4, or 15 meters of 28-AWG cables
- Programmable via pin selection or SMBus interface
- Selectable single supply operation
- Flow-thru pinout in 4mmx4mm 24-pin leadless LLP package
- >6kV HBM ESD rating
- Industrial -40 to 85°C operating temperature range

Applications

- High-speed active copper cable modules and FR-4 backplane in communication systems
- 10GE, FC, SAS, SATA 3/6 Gbps (with OOB detection), InfiniBand, CPRI, RXAUI, Many others

Typical Application

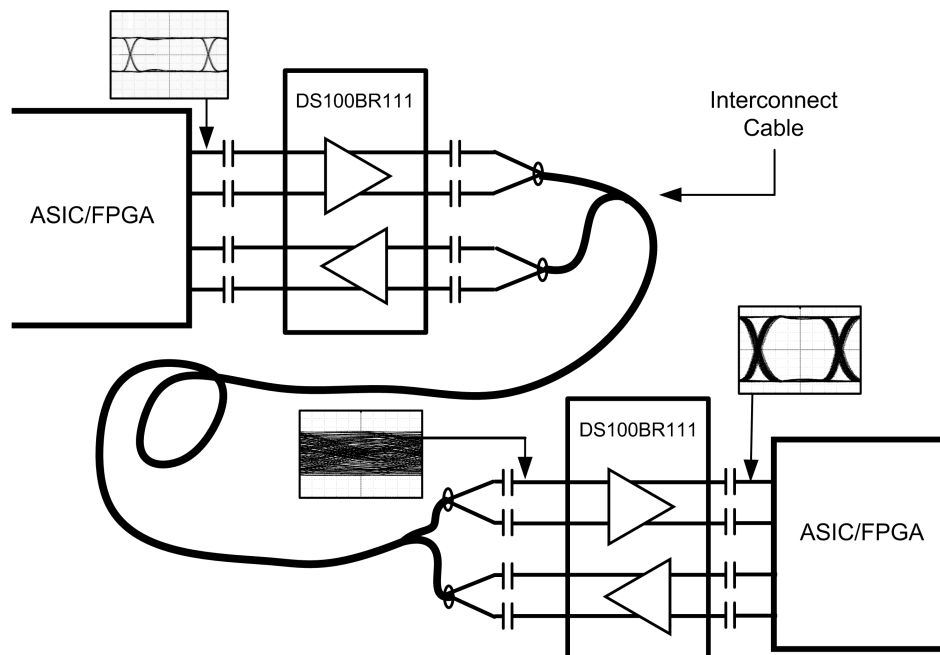

30138880

Physical Dimensions inches (millimeters) unless otherwise noted

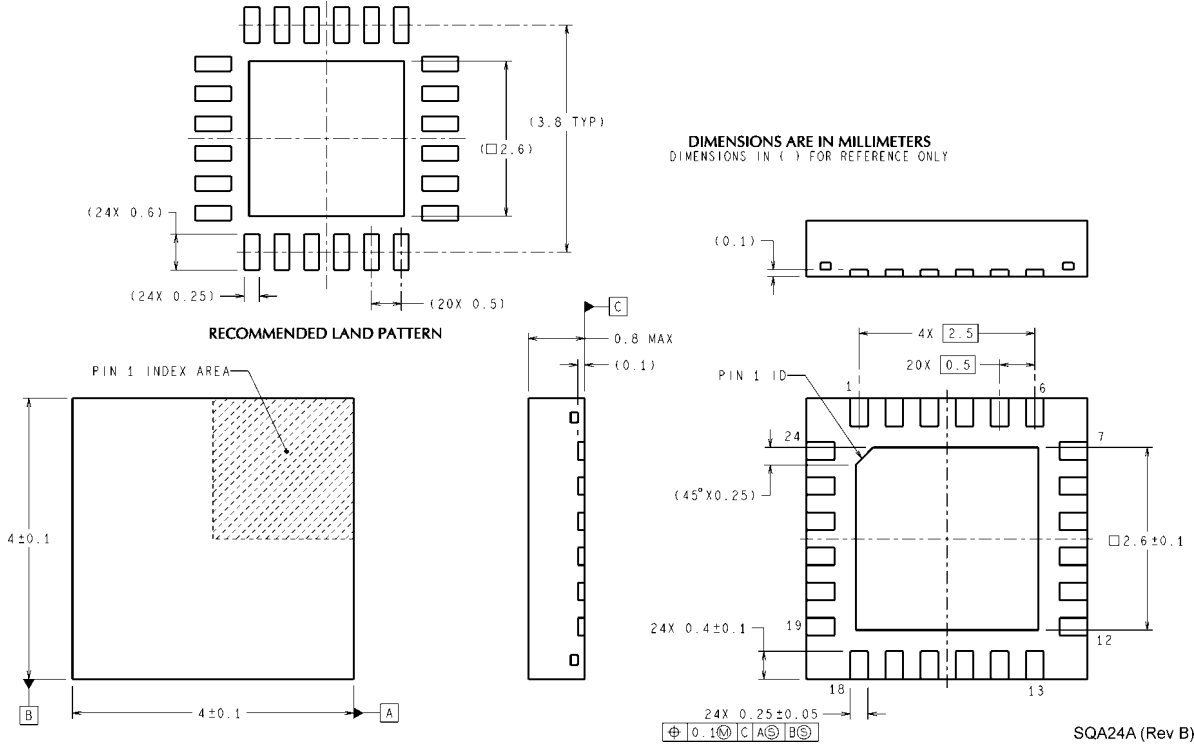

- Order Number DS100BR210SQ (Tape and Reel 2000 units)
- Order Number DS100BR210SQE (Tape and Reel 250 units)
- Order Number DS100BR111SQ (Tape and Reel 2000 units)
- Order Number DS100BR111SQE (Tape and Reel 250 units)
- NS Package Number SQA24A
- (See AN-1187 for PCB Design and Assembly Recommendations)

Notes

Notes

For more National Semiconductor product information and proven design tools, visit the following Web sites at:
www.national.com

Products		Design Support	
Amplifiers	www.national.com/amplifiers	WEBENCH® Tools	www.national.com/webench
Audio	www.national.com/audio	App Notes	www.national.com/appnotes
Clock and Timing	www.national.com/timing	Reference Designs	www.national.com/refdesigns
Data Converters	www.national.com/adc	Samples	www.national.com/samples
Interface	www.national.com/interface	Eval Boards	www.national.com/evalboards
LVDS	www.national.com/lvds	Packaging	www.national.com/packaging
Power Management	www.national.com/power	Green Compliance	www.national.com/quality/green
Switching Regulators	www.national.com/switchers	Distributors	www.national.com/contacts
LDOs	www.national.com/ldo	Quality and Reliability	www.national.com/quality
LED Lighting	www.national.com/led	Feedback/Support	www.national.com/feedback
Voltage References	www.national.com/vref	Design Made Easy	www.national.com/easy
PowerWise® Solutions	www.national.com/powerwise	Applications & Markets	www.national.com/solutions
Serial Digital Interface (SDI)	www.national.com/sdi	Mil/Aero	www.national.com/milaero
Temperature Sensors	www.national.com/tempensors	SolarMagic™	www.national.com/solarmagic
PLL/VCO	www.national.com/wireless	PowerWise® Design University	www.national.com/training

THE CONTENTS OF THIS DOCUMENT ARE PROVIDED IN CONNECTION WITH NATIONAL SEMICONDUCTOR CORPORATION ("NATIONAL") PRODUCTS. NATIONAL MAKES NO REPRESENTATIONS OR WARRANTIES WITH RESPECT TO THE ACCURACY OR COMPLETENESS OF THE CONTENTS OF THIS PUBLICATION AND RESERVES THE RIGHT TO MAKE CHANGES TO SPECIFICATIONS AND PRODUCT DESCRIPTIONS AT ANY TIME WITHOUT NOTICE. NO LICENSE, WHETHER EXPRESS, IMPLIED, ARISING BY ESTOPPEL OR OTHERWISE, TO ANY INTELLECTUAL PROPERTY RIGHTS IS GRANTED BY THIS DOCUMENT.

TESTING AND OTHER QUALITY CONTROLS ARE USED TO THE EXTENT NATIONAL DEEMS NECESSARY TO SUPPORT NATIONAL'S PRODUCT WARRANTY. EXCEPT WHERE MANDATED BY GOVERNMENT REQUIREMENTS, TESTING OF ALL PARAMETERS OF EACH PRODUCT IS NOT NECESSARILY PERFORMED. NATIONAL ASSUMES NO LIABILITY FOR APPLICATIONS ASSISTANCE OR BUYER PRODUCT DESIGN. BUYERS ARE RESPONSIBLE FOR THEIR PRODUCTS AND APPLICATIONS USING NATIONAL COMPONENTS. PRIOR TO USING OR DISTRIBUTING ANY PRODUCTS THAT INCLUDE NATIONAL COMPONENTS, BUYERS SHOULD PROVIDE ADEQUATE DESIGN, TESTING AND OPERATING SAFEGUARDS.

EXCEPT AS PROVIDED IN NATIONAL'S TERMS AND CONDITIONS OF SALE FOR SUCH PRODUCTS, NATIONAL ASSUMES NO LIABILITY WHATSOEVER, AND NATIONAL DISCLAIMS ANY EXPRESS OR IMPLIED WARRANTY RELATING TO THE SALE AND/OR USE OF NATIONAL PRODUCTS INCLUDING LIABILITY OR WARRANTIES RELATING TO FITNESS FOR A PARTICULAR PURPOSE, MERCHANTABILITY, OR INFRINGEMENT OF ANY PATENT, COPYRIGHT OR OTHER INTELLECTUAL PROPERTY RIGHT.

LIFE SUPPORT POLICY

NATIONAL'S PRODUCTS ARE NOT AUTHORIZED FOR USE AS CRITICAL COMPONENTS IN LIFE SUPPORT DEVICES OR SYSTEMS WITHOUT THE EXPRESS PRIOR WRITTEN APPROVAL OF THE CHIEF EXECUTIVE OFFICER AND GENERAL COUNSEL OF NATIONAL SEMICONDUCTOR CORPORATION. As used herein:

Life support devices or systems are devices which (a) are intended for surgical implant into the body, or (b) support or sustain life and whose failure to perform when properly used in accordance with instructions for use provided in the labeling can be reasonably expected to result in a significant injury to the user. A critical component is any component in a life support device or system whose failure to perform can be reasonably expected to cause the failure of the life support device or system or to affect its safety or effectiveness.

National Semiconductor and the National Semiconductor logo are registered trademarks of National Semiconductor Corporation. All other brand or product names may be trademarks or registered trademarks of their respective holders.

Copyright© 2011 National Semiconductor Corporation

For the most current product information visit us at www.national.com



**National Semiconductor
Americas Technical
Support Center**
Email: support@nsc.com
Tel: 1-800-272-9959

**National Semiconductor Europe
Technical Support Center**
Email: europe.support@nsc.com

**National Semiconductor Asia
Pacific Technical Support Center**
Email: ap.support@nsc.com

**National Semiconductor Japan
Technical Support Center**
Email: jpn.feedback@nsc.com