

SYNCHRONOUS DRAM MODULE

**MT18LSDT1672G – 128MB,
MT18LSDT3272G – 256MB,
MT18LSDT6472G – 512MB**

For the latest data sheet, please refer to the Micron® Web site: www.micron.com/modules

Features

- JEDEC-standard 168-pin, dual in-line memory module (DIMM)
- PC133- and PC100-compliant
- Registered inputs with one-clock delay
- Phase-lock loop (PLL) clock driver to reduce loading
- Utilizes 100 MHz and 133 MHz SDRAM components
- ECC-optimized pinout
- Single +3.3V power supply
- Fully synchronous; all signals registered on positive edge of PLL clock
- Internal pipelined operation; column address can be changed every clock cycle
- Internal SDRAM banks for hiding row access/precharge
- Programmable burst lengths: 1, 2, 4, 8, or full page
- Auto Precharge and Auto Refresh Modes
- Self Refresh Mode
- 128MB and 256MB: 64ms, 4,096-cycle refresh; 512MB: 64ms, 8,192-cycle refresh
- LVTTTL-compatible inputs and outputs
- Serial Presence-Detect (SPD)

OPTIONS

- Package
168-pin DIMM (gold)
- Frequency/CAS Latency
133 MHz/CL = 2
133 MHz/CL = 3
100 MHz/CL = 2

MARKING

G
-13E
-133
-10E

NOTE: Registered mode adds one clock cycle to CL.

Table 1: Address Table

PARAMETER	128MB	256MB	512MB
Refresh Count	4K	4K	8K
Device Config.	16 Meg x 4	32 Meg x 4	64 Meg x 4
Device Banks	4 (BA0, BA1)	4 (BA0, BA1)	4 (BA0, BA1)
Row Addressing	4K (A0–A11)	4K (A0–A11)	8K (A0–A12)
Column Addr.	1K (A0–A9)	2K (A0–A9,A11)	2K (A0–A9,A11)
Module Ranks	1 (S0,S2)	1 (S0,S2)	1 (S0,S2)

Figure 1: 168-Pin DIMM (MO-168)

Standard PCB

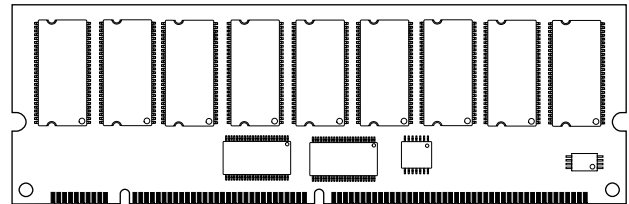

Low Profile PCB

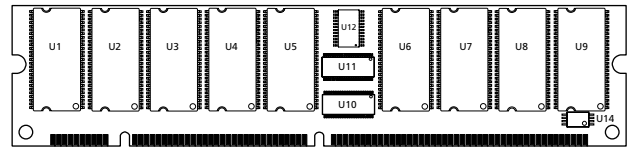

Table 2: Timing Parameters

MODULE MARKING	CLOCK FREQUENCY	ACCESS TIME		SETUP TIME	HOLD TIME
		CL = 2	CL = 3		
-13E	133 MHz	5.4ns	–	1.5	0.8
-133	133 MHz	–	5.4ns	1.5	0.8
-10E	100 MHz	9ns	7.5ns	2ns	1ns

Table 3: Part Numbers

PART NUMBER	CONFIG	SYSTEM BUS SPEED
MT18LSDT1672G-13E__	16 Meg x 72	133 MHz
MT18LSDT1672G-133__	16 Meg x 72	133 MHz
MT18LSDT1672G-10E__	16 Meg x 72	100 MHz
MT18LSDT3272G-133__	32 Meg x 72	133 MHz
MT18LSDT3272G-13E__	32 Meg x 72	133 MHz
MT18LSDT3272G-10E__	32 Meg x 72	100 MHz
MT18LSDT6472G-133__	64 Meg x 72	133 MHz
MT18LSDT6472G-13E__	64 Meg x 72	133 MHz
MT18LSDT6472G-10E__	64 Meg x 72	100 MHz

NOTE:

1. The designators for component and PCB revision are the last two characters of each part number. Consult factory for current revision codes. Example: MT18LSDT1672G-133B1

Table 4: Pin Assignment (168-Pin DIMM Front)

PIN	SYMBOL	PIN	SYMBOL	PIN	SYMBOL	PIN	SYMBOL
1	Vss	22	CB1	43	Vss	64	Vss
2	DQ0	23	Vss	44	NC	65	DQ21
3	DQ1	24	NC	45	S2#	66	DQ22
4	DQ2	25	NC	46	DQMB2	67	DQ23
5	DQ3	26	VDD	47	DQMB3	68	Vss
6	VDD	27	WE#	48	NC	69	DQ24
7	DQ4	28	DQMB0	49	VDD	70	DQ25
8	DQ5	29	DQMB1	50	NC	71	DQ26
9	DQ6	30	S0#	51	NC	72	DQ27
10	DQ7	31	NC	52	CB2	73	VDD
11	DQ8	32	Vss	53	CB3	74	DQ28
12	Vss	33	A0	54	Vss	75	DQ29
13	DQ9	34	A2	55	DQ16	76	DQ30
14	DQ10	35	A4	56	DQ17	77	DQ31
15	DQ11	36	A6	57	DQ18	78	Vss
16	DQ12	37	A8	58	DQ19	79	DNU
17	DQ13	38	A10	59	VDD	80	NC
18	VDD	39	BA1	60	DQ20	81	NC
19	DQ14	40	VDD	61	NC	82	SDA
20	DQ15	41	VDD	62	NC	83	SCL
21	CB0	42	CKO	63	CKE1	84	VDD

Table 5: Pin Assignment (168-Pin DIMM Back)

PIN	SYMBOL	PIN	SYMBOL	PIN	SYMBOL	PIN	SYMBOL
85	Vss	106	CB5	127	Vss	148	Vss
86	DQ32	107	Vss	128	CKE0	149	DQ53
87	DQ33	108	NC	129	S3#	150	DQ54
88	DQ34	109	NC	130	DQMB6	151	DQ55
89	DQ35	110	VDD	131	DQMB7	152	Vss
90	VDD	111	CAS#	132	NC	153	DQ56
91	DQ36	112	DQMB4	133	VDD	154	DQ57
92	DQ37	113	DQMB5	134	NC	155	DQ58
93	DQ38	114	S1#	135	NC	156	DQ59
94	DQ39	115	RAS#	136	CB6	157	VDD
95	DQ40	116	Vss	137	CB7	158	DQ60
96	Vss	117	A1	138	Vss	159	DQ61
97	DQ41	118	A3	139	DQ48	160	DQ62
98	DQ42	119	A5	140	DQ49	161	DQ63
99	DQ43	120	A7	141	DQ50	162	Vss
100	DQ44	121	A9	142	DQ51	163	DNU
101	DQ45	122	BA0	143	VDD	164	NC
102	VDD	123	A11	144	DQ52	165	SA0
103	DQ46	124	VDD	145	NC	166	SA1
104	DQ47	125	DNU	146	NC	167	SA2
105	CB4	126	NC/A12	147	REGE	168	VDD

NOTE:

Pin 126 is NC for 128MB and 256MB modules, A12 for 512MB module.

Figure 2: Pin Locations (168-Pin DIMM)

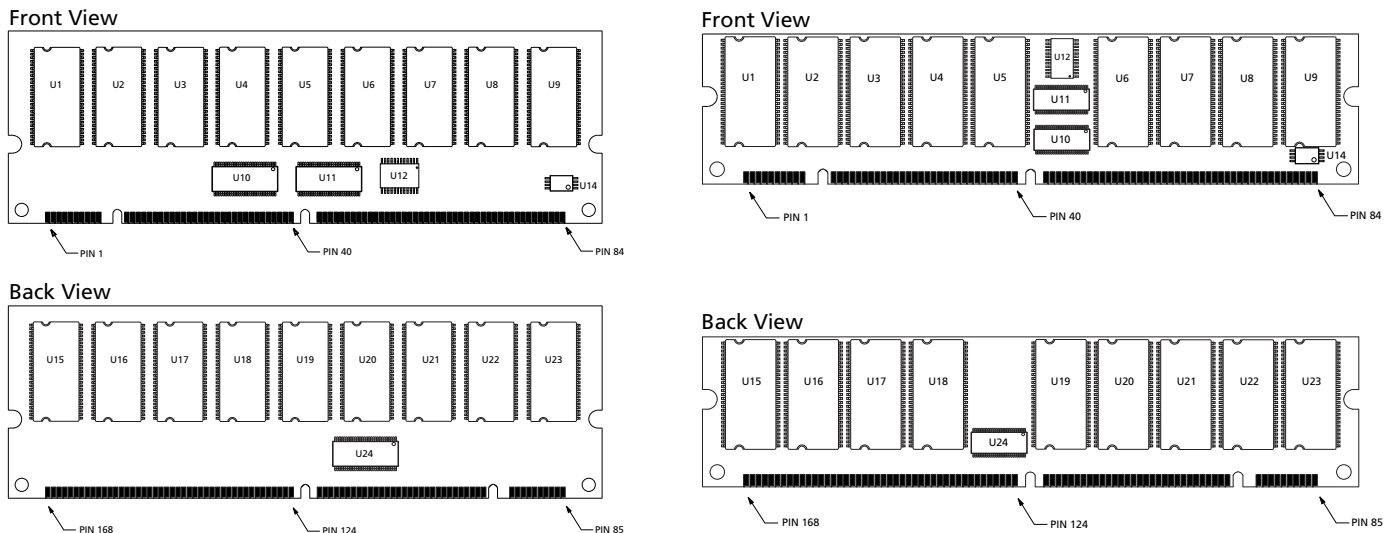

Table 6: Pin Descriptions

Pin numbers are listed in module pinout order; see pin assignment tables on page 2 for more information

PIN NUMBERS	SYMBOL	TYPE	DESCRIPTION
27, 111, 115	WE#, CAS#, RAS#	Input	Command Inputs: WE#, CAS#, and RAS# (along with S0#, S2#) define the command being entered.
42, 79, 125, 163	CK0-CK3	Input	Clock: CK0 is distributed through an on-board PLL to all devices. CK1-CK3 are terminated.
128	CKE0	Input	Clock Enable: CKE0 activates (HIGH) and deactivates (LOW) the CK0 signal. Deactivating the clock provides POWER-DOWN and SELF REFRESH operation (all device banks idle) or CLOCK SUSPEND operation (burst access in progress). CKE0 is synchronous except after the device enters power-down and self refresh modes, where CKE0 becomes asynchronous until after exiting the same mode. The input buffers, including CK0, are disabled during power-down and self refresh modes, providing low standby power.
30, 45	S0#, S2#	Input	Chip Select: S0#, S2# enable (registered LOW) and disable (registered HIGH) the command decoder. All commands are masked when S0#, S2# are registered HIGH. S0#, S2# are considered part of the command code.
28-29, 46-47, 112-113, 130-131	DQMB0- DQMB7	Input	Input/Output Mask: DQMB is an input mask signal for write accesses and an output enable signal for read accesses. Input data is masked when DQMB is sampled HIGH during a WRITE cycle. The output buffers are placed in a High-Z state (two-clock latency) when DQMB is sampled HIGH during a READ cycle.
39, 122	BA0, BA1	Input	Bank Address: BA0 and BA1 define to which device bank the ACTIVE, READ, WRITE or PRECHARGE command is being applied.
33-38, 117-121, 123, 126 (512MB)	A0-A11 (128MB/ 256MB) A0-A12 (512MB)	Input	Address Inputs: A0-A11 (128MB/256MB) or A0-A12 (512MB) are sampled during the ACTIVE command (device row-address A0-A11/12) and READ/WRITE command (device column-address A0-A9 (128MB) or A0- A9/A11 (256MB/ 512MB), with A10 defining auto precharge) to select one location out of the memory array in the respective device bank. A10 is sampled during a PRECHARGE command to determine if both device banks are to be precharged (A10 HIGH). The address inputs also provide the op-code during a LOAD MODE REGISTER command.
81	WP	Input	Write Protect: Serial presence-detect hardware write protect.
83	SCL	Input	Serial Clock for Presence-Detect: SCL is used to synchronize the presence-detect data transfer to and from the module.
165-167	SA0-SA2	Input	Presence-Detect Address Inputs: These pins are used to configure the presence-detect device.
147	REGE	Input	Register Enable.
2-5, 7-11, 13-17, 19-20, 55-58, 60, 65-67, 69-72, 74-77, 86-89, 91-95, 97-101, 103-104, 139-142, 144, 149-151, 153-156, 158-161	DQ0-DQ63	Input/Output	Data I/Os: Data bus.
21-22, 52-53, 105-106, 136-137	CB0-CB7	Input/Output	Check Bits.

Table 6: Pin Descriptions (Continued)

Pin numbers are listed in module pinout order; see pin assignment tables on page 2 for more information

PIN NUMBERS	SYMBOL	TYPE	DESCRIPTION
82	SDA	Input/ Output	Serial Presence-Detect Data: SDA is a bidirectional pin used to transfer addresses and data into and data out of the presence-detect portion of the module.
6, 18, 26, 40-41, 49, 59, 73, 84, 90, 102, 110, 124, 133, 143, 157, 168	VDD	Supply	Power Supply: +3.3V \pm 0.3V.
1, 12, 23, 32, 43, 54, 64, 68, 78, 85, 96, 107, 116, 127, 138, 148, 152, 162	Vss	Supply	Ground.
24, 25, 26, 31, 44, 48, 50, 51, 61, 62, 63, 80, 108, 109, 114, 126 (128/256MB), 129, 132, 134, 135, 145, 146, 164	NC	–	Not Connected: These pins are not connected on these modules.

Figure 3: Functional Block Diagram

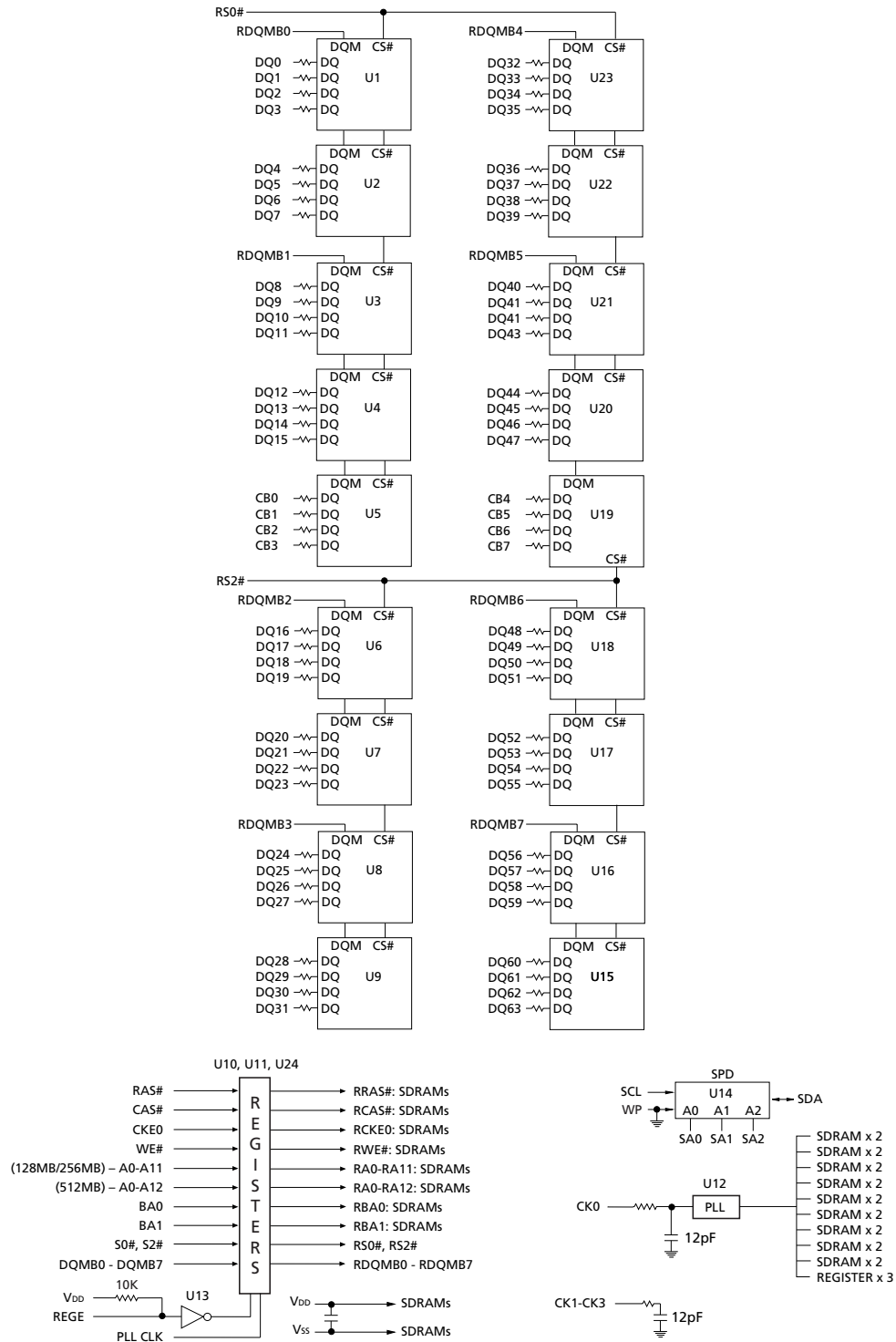

NOTE:

1. All resistor values are 10 ohms unless otherwise specified.
2. Per industry standard, Micron uses various component speed grades as referenced in the Module Part Numbering Guide at www.micron.com/numberguide.

SDRAMs = MT48LC16M4A2TG for 128MB
 SDRAMs = MT48LC32M4A2TG for 256MB
 SDRAMs = MT48LC64M4A2TG for 512MB

General Description

The MT18LSDT1672G, MT18LSDT3272G, and MT18LSDT6472G are high-speed CMOS, dynamic random-access, 128MB, 256MB, and 512MB memory modules organized in a x72 (ECC) configuration. These modules use internally configured quad-bank SDRAM devices, with a synchronous interface (all signals are registered on the positive edge of clock signal CK0).

Read and write accesses to the SDRAM modules are burst oriented; accesses start at a selected location and continue for a programmed number of locations in a programmed sequence. Accesses begin with the registration of an ACTIVE command, which is then followed by a READ or WRITE command. The address bits registered coincident with the ACTIVE command are used to select the device bank and row to be accessed (BA0, BA1 select the device bank, A0-A11 select the device row for the 128MB and 256MB modules; A0-A12 select the device row for the 512MB module). The address bits registered coincident with the READ or WRITE command are used to select the starting device column location for the burst access.

These modules provide for programmable read or write burst lengths of 1, 2, 4, or 8 locations, or full page, with a burst terminate option. An auto precharge function may be enabled to provide a self-timed device row precharge that is initiated at the end of the burst sequence.

These modules use an internal pipelined architecture. Precharging one device bank while accessing one of the other three device banks will hide the PRECHARGE cycles and provide seamless, high-speed, random-access operation.

These modules are designed to operate in 3.3V, low-power memory systems. An auto refresh mode is provided, along with a power-saving, power-down mode. All inputs and outputs are LVTTTL-compatible.

SDRAM modules offer substantial advances in DRAM operating performance, including the ability to synchronously burst data at a high data rate with automatic device column-address generation, the ability to interleave between device banks in order to hide precharge time, and the capability to randomly change device column addresses on each clock cycle during a burst access. For more information regarding SDRAM operation, refer to the 64Mb, 128Mb, and 256Mb SDRAM data sheets.

PLL and Register Operation

These modules can be operated in either registered mode (REGE pin HIGH), where the control/address input signals are latched in the register on one rising

clock edge and sent to the SDRAM devices on the following rising clock edge (data access is delayed by one clock), or in buffered mode (REGE pin LOW) where the input signals pass through the register/buffer to the SDRAM devices on the same clock. A phase-lock loop (PLL) on the modules is used to redrive the clock signals to the SDRAM devices to minimize system clock loading (CK0 is connected to the PLL, and CK1, CK2, and CK3 are terminated).

Serial Presence-Detect Operation

These modules incorporate serial presence-detect (SPD). The SPD function is implemented using a 2,048-bit EEPROM. This nonvolatile storage device contains 256 bytes. The first 128 bytes can be programmed by Micron to identify the module type and various SDRAM organizations and timing parameters. The remaining 128 bytes of storage are available for use by the customer. System READ/WRITE operations between the master (system logic) and the slave EEPROM device (DIMM) occur via a standard I²C bus using the DIMM's SCL (clock) and SDA (data) signals, together with SA (2:0), which provide eight unique DIMM/EEPROM addresses. Write protect (WP) is tied to ground on the module, permanently disabling hardware write protect.

SDRAM Component Description

In general, the 64Mb, 128Mb, and 256Mb SDRAM memory devices used for these modules are quad-bank DRAMs, that operate at 3.3V and include a synchronous interface (all signals are registered on the positive edge of the clock signal, CK). The four banks of a x4, 64Mb device are each configured as 4,096 bit-rows, by 1,024 bit-columns, by 4 input/output bits. The four banks of a x4, 128Mb device are each configured as 4,096 bit-rows, by 2,048 bit-columns, by 4 input/output bits. The four banks of a x4, 256MB device are configured as 8,192 bit-rows, by 2,048 bit columns, by 4 input/output bits.

Module Functional Description

Read and write accesses to the SDRAM are burst oriented; accesses start at a selected location and continue for a programmed number of locations in a programmed sequence. Accesses begin with the registration of an ACTIVE command, which is then followed by a READ or WRITE command. The address bits registered coincident with the ACTIVE command are used to select the device bank and row to be accessed BA0 and BA1 select the device bank, A0-A11 (for 128MB and 256MB module), or A0-A12 (for 512MB

module), select the device row. The address bits A0-A9 (for 64MB) or A0-A9, A11 (for the 256MB and 512MB module), registered coincident with the READ or WRITE command are used to select the starting device column location for the burst access.

Prior to normal operation, the SDRAM must be initialized. The following sections provide detailed information covering device initialization, register definition, command descriptions and device operation.

Initialization

SDRAMs must be powered up and initialized in a predefined manner. Operational procedures other than those specified may result in undefined operation. Once power is applied to Vdd and VddQ (simultaneously) and the clock is stable (stable clock is defined as a signal cycling within timing constraints specified for the clock pin), the SDRAM requires a 100µs delay prior to issuing any command other than a COMMAND INHIBIT or NOP. Starting at some point during this 100µs period and continuing at least through the end of this period, Command Inhibit or NOP commands should be applied.

Once the 100µs delay has been satisfied with at least one Command Inhibit or NOP command having been applied, a PRECHARGE command should be applied. All device banks must then be precharged, thereby placing the device in the all device banks idle state.

Once in the idle state, two AUTO refresh cycles must be performed. After the AUTO refresh cycles are complete, the SDRAM is ready for mode register programming. Because the mode register will power up in an unknown state, it should be loaded prior to applying any operational command.

Mode Register Definition

The mode register is used to define the specific mode of operation of the SDRAM. This definition includes the selection of a burst length, a burst type, a CAS latency, an operating mode and a write burst mode, as shown in Mode Register Definition Diagram. The mode register is programmed via the LOAD MODE REGISTER command and will retain the stored information until it is programmed again or the device loses power.

Mode register bits M0-M2 specify the burst length, M3 specifies the type of burst (sequential or interleaved), M4-M6 specify the CAS latency, M7 and M8 specify the operating mode, M9 specifies the write

burst mode, and M10 and M11 are reserved for future use. For the 512MB module, address A12 (M12) is undefined but should be driven LOW during loading of the mode register.

The mode register must be loaded when all device banks are idle, and the controller must wait the specified time before initiating the subsequent operation. Violating either of these requirements will result in unspecified operation.

Figure 4: Mode Register Definition Diagram

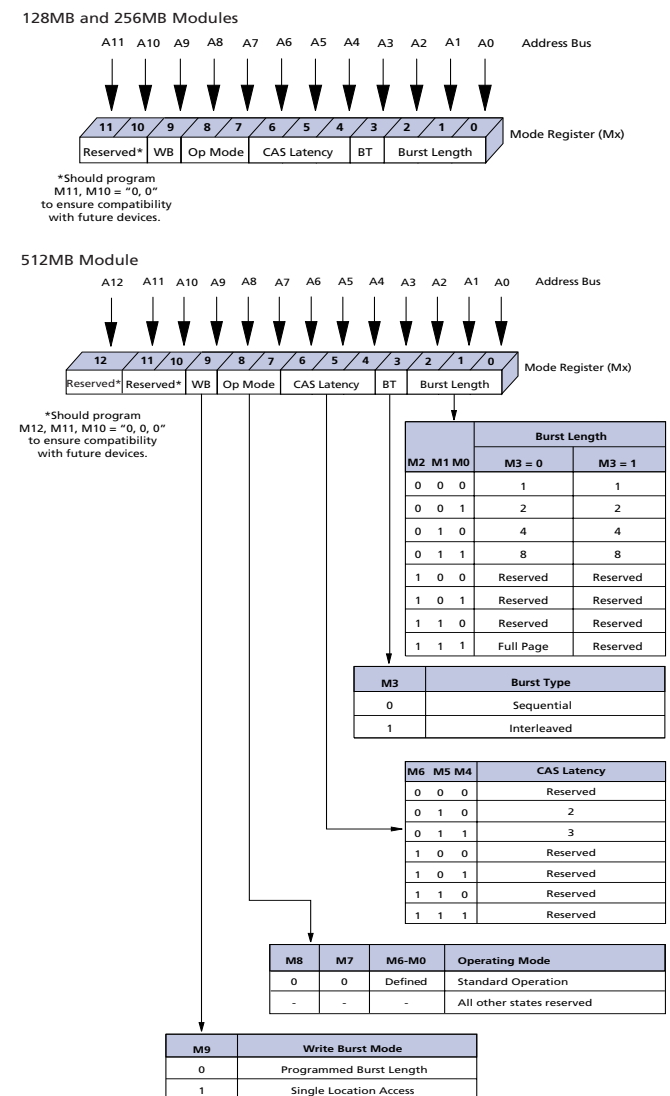

Burst Length

Read and write accesses to the SDRAM are burst oriented, with the burst length being programmable, as shown in Mode Register Definition Diagram. The burst length determines the maximum number of column locations that can be accessed for a given READ or WRITE command. Burst lengths of 1, 2, 4, or 8 locations are available for both the sequential and the interleaved burst types, and a full-page burst is available for the sequential type. The full-page burst is used in conjunction with the BURST TERMINATE command to generate arbitrary burst lengths.

Reserved states should not be used, as unknown operation or incompatibility with future versions may result.

When a READ or WRITE command is issued, a block of columns equal to the burst length is effectively selected. All accesses for that burst take place within this block, meaning that the burst will wrap within the block if a boundary is reached, as shown in the Burst Definition Table. The block is uniquely selected by A1-A9 (64MB) or A1-A9, A11 (128MB/256MB) when the burst length is set to two; A2-A9 or A2-A9, A11 when the burst length is set to four; and by A3-A9 or A3-A9, A11 when the burst length is set to eight. The remaining (least significant) address bit(s) is (are) used to select the starting location within the block. Full-page bursts wrap within the page if the boundary is reached, as shown in the Burst Definition Table.

Burst Type

Accesses within a given burst may be programmed to be either sequential or interleaved; this is referred to as the burst type and is selected via bit M3.

The ordering of accesses within a burst is determined by the burst length, the burst type and the starting column address, as shown in the Burst Definition Table.

CAS Latency

The CAS latency is the delay, in clock cycles, between the registration of a READ command and the availability of the first piece of output data. The latency can be set to two or three clocks.

Table 7: Burst Definition Table

BURST LENGTH	STARTING COLUMN ADDRESS		ORDER OF ACCESSES WITHIN A BURST		
			TYPE = SEQUENTIAL	TYPE = INTERLEAVED	
2	A0				
	0		0-1	0-1	
	1		1-0	1-0	
4	A1 A0				
	0	0	0-1-2-3	0-1-2-3	
	0	1	1-2-3-0	1-0-3-2	
	1	0	2-3-0-1	2-3-0-1	
	1	1	3-0-1-2	3-2-1-0	
8	A2 A1 A0				
	0	0	0	0-1-2-3-4-5-6-7	0-1-2-3-4-5-6-7
	0	0	1	1-2-3-4-5-6-7-0	1-0-3-2-5-4-7-6
	0	1	0	2-3-4-5-6-7-0-1	2-3-0-1-6-7-4-5
	0	1	1	3-4-5-6-7-0-1-2	3-2-1-0-7-6-5-4
	1	0	0	4-5-6-7-0-1-2-3	4-5-6-7-0-1-2-3
	1	0	1	5-6-7-0-1-2-3-4	5-4-7-6-1-0-3-2
	1	1	0	6-7-0-1-2-3-4-5	6-7-4-5-2-3-0-1
1	1	1	7-0-1-2-3-4-5-6	7-6-5-4-3-2-1-0	
Full Page (y)	n = A0-A9, or n = A0-A9/A11 (location 0-y)		Cn, Cn+1, Cn+2, Cn+3, Cn+4..., ...Cn-1, Cn...	Not supported	

NOTE:

- For full-page accesses: $y = 1,024$ (128MB); $y = 2,048$ (256MB and 512MB).
- For a burst length of two, A1-A9 (128MB) or A1-A9/A11 (256MB and 512MB) select the block of two burst; A0 selects the starting column within the block.
- For a burst length of four, A2-A9 or A2-A9/A11 select the block of four burst; A0-A1 select the starting column within the block.
- For a burst length of eight, A3-A9 or A3-A9/A11 select the block of eight burst; A0-A2 select the starting column within the block.
- For a full-page burst, the full row is selected and A0-A9 or A0-A9/A11 select the starting column.
- Whenever a boundary of the block is reached within a given sequence above, the following access wraps within the block.
- For a burst length of one, A0-A9 or A0-A9/A11 select the unique column to be accessed, and Mode Register bit M3 is ignored.

If a READ command is registered at clock edge n , and the latency is m clocks, the data will be available by clock edge $n + m$. The DQs will start driving as a result of the clock edge one cycle earlier ($n + m - 1$), and provided that the relevant access times are met, the data will be valid by clock edge $n + m$. For example, assuming that the clock cycle time is such that all relevant access times are met, if a read command is registered at T_0 and the latency is programmed to two clocks, the DQs will start driving after T_1 and the data will be valid by T_2 , as shown in the CAS Latency Diagram. The CAS Latency Table indicate the operating frequencies at which each CAS latency setting can be used.

Reserved states should not be used as unknown operation or incompatibility with future versions may result.

Operating Mode

The normal operating mode is selected by setting M7 and M8 to zero; the other combinations of values for M7 and M8 are reserved for future use and/or test modes. The programmed burst length applies to both read and write bursts.

Test modes and reserved states should not be used because unknown operation or incompatibility with future versions may result.

Write Burst Mode

When M9 = 0, the burst length programmed via M0-M2 applies to both read and write bursts; when M9 = 1, the programmed burst length applies to read bursts, but write accesses are single-location (nonburst) accesses.

Figure 5: CAS Latency Diagram

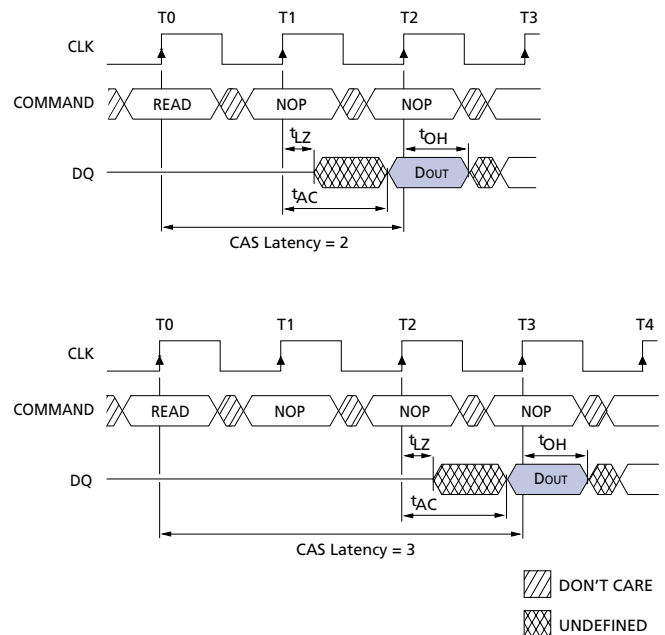

Table 8: CAS Latency Table

Registered mode will add one clock cycle to CAS Latency (CL) listed

SPEED	ALLOWABLE OPERATING FREQUENCY (MHZ)	
	CL = 2	CL = 3
-13E	≤ 133	≤ 143
-133	≤ 100	≤ 133
-10E	≤ 100	NA

Commands

The Truth Table provides a quick reference of available commands. This is followed by a written description of each command. For a more detailed

description of commands and operations refer to the 64Mb, 128Mb, or 256Mb SDRAM component datasheets.

Table 9: Truth Table – SDRAM Commands and DQMB Operation

Note: 1; notes appear below table)

NAME (FUNCTION)	CS#	RAS#	CAS#	WE#	DQMB	ADDR	DQS	NOTES
COMMAND INHIBIT (NOP)	H	X	X	X	X	X	X	
NO OPERATION (NOP)	L	H	H	H	X	X	X	
ACTIVE (Select bank and activate row)	L	L	H	H	X	Bank/Row	X	3
READ (Select bank and column, and start READ burst)	L	H	L	H	L/H ⁸	Bank/Col	X	4
WRITE (Select bank and column, and start WRITE burst)	L	H	L	L	L/H ⁸	Bank/Col	Valid	4
BURST TERMINATE	L	H	H	L	X	X	Active	
PRECHARGE (Deactivate row in bank or banks)	L	L	H	L	X	Code	X	5
AUTO REFRESH or SELF REFRESH (Enter self refresh mode)	L	L	L	H	X	X	X	6, 7
LOAD MODE REGISTER	L	L	L	L	X	Op-Code	X	2
Write Enable/Output Enable	–	–	–	–	L	–	Active	8
Write Inhibit/Output High-Z	–	–	–	–	H	–	High-Z	8

NOTE:

1. CKE is HIGH for all commands shown except Self Refresh.
2. A0–A11 (128MB and 256MB), A0–A12 (512MB) define the op-code written to the Mode Register, and should be driven low.
3. A0–A11 (128MB and 256MB), A0–A12 (512MB) provide device row address. BA0, BA1 determine which device bank is made active.
4. A0–A9 provide device column address for 128MB module; A0–A9/A11 for 256MB and 512MB modules; A10 HIGH enables the auto precharge feature (nonpersistent), while A10 LOW disables the auto precharge feature; BA0, BA1 determine which device bank is being read from or written to.
5. A10 LOW: BA0, BA1 determine which device bank is being precharged. A10 HIGH: both device banks are precharged and BA0, BA1 are “Don’t Care.”
6. This command is Auto Refresh if CKE is HIGH, Self Refresh if CKE is LOW.
7. Internal refresh counter controls row addressing; all inputs and I/Os are “Don’t Care” except for CKE.
8. Activates or deactivates the DQs during WRITES (zero-clock delay) and READs (two-clock delay).

Absolute Maximum Ratings

Stresses greater than those listed may cause permanent damage to the device. This is a stress rating only, and functional operation of the device at these or any other conditions above those indicated in the opera-

tional sections of this specification is not implied. Exposure to absolute maximum rating conditions for extended periods may affect reliability.

Voltage on VDD Supply
Relative to VSS -1V to +4.6V
Voltage on Inputs, NC or I/O Pins
Relative to VSS -1V to +4.6V
Operating Temperature
T_A (ambient) 0°C to +70°C

Storage Temperature (plastic) -55°C to +150°C
Power Dissipation 18W

Table 10: DC Electrical Characteristics and Operating Conditions

Notes: 1, 5, 6; notes appear on page 15; 0°C ≤ T_A ≤ +70°C

PARAMETER/CONDITION	SYMBOL	MIN	MAX	UNITS	NOTES
SUPPLY VOLTAGE	VDD, VDDQ	3	3.6	V	
INPUT HIGH VOLTAGE: Logic 1; All inputs	V _{IH}	2	V _{DD} + 0.3	V	22
INPUT LOW VOLTAGE: Logic 0; All inputs	V _{IL}	-0.3	0.8	V	22
INPUT LEAKAGE CURRENT: Any input 0V ≤ V _{IN} ≤ V _{DD} (All other pins not under test = 0V) For inputs: A0-A12, BA0, BA1, RAS#, CAS#, WE#, CKE0	I _{IA}	-10	10	μA	33
INPUT LEAKAGE CURRENT: Any input 0V ≤ V _{IN} ≤ V _{DD} (All other pins not under test = 0V) For inputs: S#, DQMB	I _{IB}	-5	5	μA	33
OUTPUT LEAKAGE CURRENT: DQs are disabled; 0V ≤ V _{OUT} ≤ V _{DDQ}	I _{OZ}	-10	10	μA	33
OUTPUT LEVELS: Output High Voltage (I _{OUT} = -4mA)	V _{OH}	2.4	-	V	
Output Low Voltage (I _{OUT} = 4mA)	V _{OL}	-	0.4	V	

Table 11: IDD Specifications and Conditions (128MB)

SDRAM components only

Notes: 1, 6, 11, 13; notes appear on page 15; 0°C ≤ T_A ≤ +70°C; V_{DD} = V_{DDQ} - +3.3V ±0.3V

PARAMETER/CONDITION	SYMBOL	MAX			UNITS	NOTES
		-13E	-133	-10E		
OPERATING CURRENT: Active Mode; Burst = 2; READ or WRITE; t _{RC} = t _{RC} (MIN)	IDD1	1,250	2,070	1,710	mA	3, 18, 19, 30
STANDBY CURRENT: Power-Down Mode; All device banks idle; CKE = LOW	IDD2	36	36	36	mA	30
STANDBY CURRENT: Active Mode; CKE = HIGH; CS# = HIGH; All device banks active after t _{RCD} met; No accesses in progress	IDD3	810	810	630	mA	3, 12, 19, 30
OPERATING CURRENT: Burst Mode; Continuous burst; READ or WRITE; All device banks active	IDD4	2,700	2,520	2,160	mA	3, 18, 19, 30
AUTO REFRESH CURRENT CS# = HIGH; CKE = HIGH	t _{RFC} = t _{RFC} (MIN)	4,140	3,780	3,420	mA	3, 12, 18, 19, 30, 31
	t _{RFC} = 15.6 μs	54	54	54	mA	
SELF REFRESH CURRENT: CKE ≤ 0.2V	IDD7	18	18	18	mA	4

Table 12: IDD Specifications and Conditions (256MB)

SDRAM components only

 Notes: 1, 6, 11, 13; notes appear on page 15; $0^{\circ}\text{C} \leq T_A \leq +70^{\circ}\text{C}$; $V_{DD} = V_{DDQ} - +3.3\text{V} \pm 0.3\text{V}$

PARAMETER/CONDITION	SYMBOL	MAX			UNITS	NOTES
		-13E	-133	-10E		
OPERATING CURRENT: Active Mode; Burst = 2; READ or WRITE; $t_{RC} = t_{RC}(\text{MIN})$	IDD1	2,880	2,700	2,520	mA	3, 18, 19, 30
STANDBY CURRENT: Power-Down Mode; All device banks idle; CKE = LOW	IDD2	36	36	36	mA	30
STANDBY CURRENT: Active Mode; CKE = HIGH; CS# = HIGH; All device banks active after t_{RCD} met; No accesses in progress	IDD3	900	900	720	mA	3, 12, 19, 30
OPERATING CURRENT: Burst Mode; Continuous burst; READ or WRITE; All device banks active	IDD4	2,970	2,700	2,520	mA	3, 18, 19, 30
AUTO REFRESH CURRENT CS# = HIGH; CKE = HIGH	$t_{RFC} = t_{RFC}(\text{MIN})$	5,940	5,580	4,860	mA	3, 12, 18, 19, 30, 31
	$t_{RFC} = 15.6 \mu\text{s}$	54	54	54	mA	
SELF REFRESH CURRENT: CKE $\leq 0.2\text{V}$	IDD7	36	36	36	mA	4

Table 13: IDD Specifications and Conditions (512MB)

SDRAM components only

 Notes: 1, 6, 11, 13; notes appear on page 15; $0^{\circ}\text{C} \leq T_A \leq +70^{\circ}\text{C}$; $V_{DD} = V_{DDQ} - +3.3\text{V} \pm 0.3\text{V}$

PARAMETER/CONDITION	SYMBOL	MAX			UNITS	NOTES
		-13E	-133	-10E		
OPERATING CURRENT: Active Mode; Burst = 2; READ or WRITE; $t_{RC} = t_{RC}(\text{MIN})$	IDD1	2,430	2,250	2,250	mA	3, 18, 19, 30
STANDBY CURRENT: Power-Down Mode; All device banks idle; CKE = LOW	IDD2	36	36	36	mA	30
STANDBY CURRENT: Active Mode; CKE = HIGH; CS# = HIGH; All device banks active after t_{RCD} met; No accesses in progress	IDD3	720	720	720	mA	3, 12, 19, 30
OPERATING CURRENT: Burst Mode; Continuous burst; READ or WRITE; All device banks active	IDD4	2,430	2,430	2,430	mA	3, 18, 19, 30
AUTO REFRESH CURRENT CS# = HIGH; CKE = HIGH	$t_{RFC} = t_{RFC}(\text{MIN})$	5,130	4,860	4,860	mA	3, 12, 18, 19, 30, 31
	$t_{RFC} = 15.6 \mu\text{s}$	63	63	63	mA	
SELF REFRESH CURRENT: CKE $\leq 0.2\text{V}$	IDD7	45	45	45	mA	4

Table 14: CAPACITANCE (128MB, 256MB, and 512MB)

Note: 2; notes appear on page 15

PARAMETER	SYMBOL	MIN	TYP	MAX	UNITS
Input Capacitance: A0-A12, BA0, BA1, RAS#, CAS#, WE#, CKE0	CI1	–	8	–	pF
Input Capacitance: S0#, S2#, DQMB0-DQMB7	CI2	–	4	–	pF
Input Capacitance: CK0	CI3	–	16	–	pF
Input Capacitance: SCL, SA0-SA2, SDA	CI4	–	–	10	pF
Input Capacitance: CK1-CK3	CI5	–	12	–	pF
Input Capacitance: REGE	CI6	1.5	–	12	pF
Input/Output Capacitance: DQ0-DQ63, CB0-CB3, CB4-CB7	CI0	8	–	12	pF

Table 15: SDRAM Component Electrical Characteristics and Recommended AC Operating Conditions

Notes: 5, 6, 8, 9, 11; notes appear on page 15

AC CHARACTERISTICS		-13E		-133		-10E		UNITS	NOTES	
PARAMETER	SYMBOL	MIN	MAX	MIN	MAX	MIN	MAX			
Access time from CLK(pos.edge)	CL=3	$t_{AC(3)}$		5.4		5.4		6	ns	27
	CL=2	$t_{AC(2)}$		5.4		6		6	ns	
Address hold time		t_{AH}	0.8		0.8		1		ns	
Address setup time		t_{AS}	1.5		1.5		2		ns	
CLK high-level width		t_{CH}	2.5		2.5		3		ns	
CLK low-level width		t_{CL}	2.5		2.5		3		ns	
Clock cycle time	CL=3	$t_{CK(3)}$	7		7.5		8		ns	23
	CL = 2	$t_{CK(2)}$	7.5		10		10		ns	23
CKE hold time		t_{CKH}	0.8		0.8		1		ns	
CKE setup time		t_{CKS}	1.5		1.5		2		ns	
CS#, RAS#, CAS#, WE#, DQM hold time		t_{CMH}	0.8		0.8		1		ns	
CS#, RAS#, CAS#, WE#, DQM setup time		t_{CMS}	1.5		1.5		2		ns	
Data-in hold time		t_{DH}	0.8		0.8		1		ns	
Data-in setup time		t_{DS}	1.5		1.5		2		ns	
Data-out high-impedance time	CL = 3	$t_{HZ(3)}$		5.4		5.4		6	ns	10
	CL = 2	$t_{HZ(2)}$		5.4		6		6	ns	10
Data-out low-impedance time		t_{LZ}	1		1		1		ns	
Data-out hold time (load)		t_{OH}	3		3		3		ns	
Data-out hold time (no load)		t_{OH_N}	1.8		1.8		1.8		ns	28
ACTIVE to PRE CHARGE command		t_{RAS}	37	120,000	44	120,000	50	120,000	ns	29
ACTIVE to ACTIVE command period		t_{RC}	60		66		70		ns	
ACTIVE to READ or WRITE delay		t_{RCD}	15		20		20		ns	
Refresh period (8,192 rows)		t_{REF}		64		64		64	ms	
AUTO REFRESH period		t_{RFC}	66		66		70		ns	
PRE CHARGE command period		t_{RP}	15		20		20		ns	

Table 15: SDRAM Component Electrical Characteristics and Recommended AC Operating Conditions (Continued)

Notes: 5, 6, 8, 9, 11; notes appear on page 15

AC CHARACTERISTICS		-13E		-133		-10E		UNITS	NOTES
PARAMETER	SYMBOL	MIN	MAX	MIN	MAX	MIN	MAX		
ACTIV bank <i>a</i> to ACTIVE bank <i>b</i> command	t_{RRD}	14		15		20		ns	
Transition time	t_T	0.3	1.2	0.3	1.2	0.3	1.2	ns	7
WRITE recovery time	t_{WR}	1 CLK + 7ns		1 CLK + 7.5ns		1 CLK + 7ns		ns	24
			14		15		15		ns
Exit SELF REFRESH to ACTIVE command	t_{XSR}	67		75		80		ns	20

Table 16: AC Functional Characteristics

Notes: 5, 6, 7, 8, 9, 11; notes appear on page 15

PARAMETER		SYMBOL	-13E	-133	-10E	UNITS	NOTES
READ/WRITE command to READ/WRITE command		t_{CCD}	1	1	1	t_{CK}	17
CKE to clock disable or power-down entry mode		t_{CKED}	1	1	1	t_{CK}	14, 32
CKE to clock enable or power-down exit setup mode		t_{PED}	1	1	1	t_{CK}	14, 32
DQM to input data delay		t_{DQD}	0	0	0	t_{CK}	17, 32
DQM to data mask during WRITES		t_{DQM}	0	0	0	t_{CK}	17, 32
DQM to data high-impedance during READS		t_{DQZ}	2	2	2	t_{CK}	17, 32
WRITE command to input data delay		t_{DWD}	0	0	0	t_{CK}	17, 32
Data-in to ACTIVE command		t_{DAL}	4	5	4	t_{CK}	15, 21, 32
Data-in to PRE CHARGE command		t_{DPL}	2	2	2	t_{CK}	16, 21, 32
Last data-in to burst STOP command		t_{BDL}	1	1	1	t_{CK}	17, 32
Last data-in to new READ/WRITE command		t_{CDL}	1	1	1	t_{CK}	17, 32
Last data-in to PRECHARGE command		t_{RDL}	2	2	2	t_{CK}	16, 21, 32
LOAD MODE REGISTER command to ACTIVE or REFRESH command		t_{MRD}	2	2	2	t_{CK}	26
Data-out to high-impedance from PRECHARGE command	CL=3	$t_{ROH(3)}$	3	3	3	t_{CK}	17, 32
	CL = 2	$t_{ROH(2)}$	2	2	2	t_{CK}	17, 32

Notes

1. All voltages referenced to VSS.
2. This parameter is sampled. V_{DD} , $V_{VDDQ} = +3.3V$; $f = 1\text{ MHz}$, $T_A = 25^\circ\text{C}$; pin under test biased at 1.4V.
3. I_{DD} is dependent on output loading and cycle rates. Specified values are obtained with minimum cycle time and the outputs open.
4. Enables on-chip refresh and address counters.
5. The minimum specifications are used only to indicate cycle time at which proper operation over the full temperature range is ensured; ($0^\circ\text{C} \leq T_A \leq +70^\circ\text{C}$).
6. An initial pause of 100 μs is required after power-up, followed by two AUTO Refresh commands, before proper device operation is ensured. (V_{DD} and V_{DDQ} must be powered up simultaneously. V_{SS} and V_{SSQ} must be at same potential.) The two AUTO Refresh command wake-ups should be repeated any time the tREF refresh requirement is exceeded.
7. AC characteristics assume $t_T = 1\text{ ns}$.
8. In addition to meeting the transition rate specification, the clock and CKE must transit between V_{IH} and V_{IL} (or between V_{IL} and V_{IH}) in a monotonic manner.
9. Outputs measured at 1.5V with equivalent load:

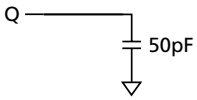
10. t_{HZ} defines the time at which the output achieves the open circuit condition; it is not a reference to V_{OH} or V_{OL} . The last valid data element will meet t_{OH} before going High-Z.
11. AC timing and I_{DD} tests have $V_{IL} = 0V$ and $V_{IH} = 3V$, with timing referenced to 1.5V crossover point. If the input transition time is longer than 1 ns, then the timing is referenced at $V_{IL}(\text{MAX})$ and $V_{IH}(\text{MIN})$ and no longer at the 1.5V crossover point.
12. Other input signals are allowed to transition no more than once every two clocks and are otherwise at valid V_{IH} or V_{IL} levels.
13. I_{DD} specifications are tested after the device is properly initialized.
14. Timing actually specified by t_{CKS} ; clock(s) specified as a reference only at minimum cycle rate.
15. Timing actually specified by t_{WR} plus t_{RP} ; clock(s) specified as a reference only at minimum cycle rate.
16. Timing actually specified by t_{WR} .
17. Required clocks are specified by JEDEC functionality and are not dependent on any timing parameter.
18. The I_{DD} current will increase or decrease proportionally according to the amount of frequency alteration for the test condition.
19. Address transitions average one transition every two clocks.
20. CLK must be toggled a minimum of two times during this period.
21. Based on $t_{CK} = 10\text{ ns}$ for -10E, and $t_{CK} = 7.5\text{ ns}$ for -133 and -13E.
22. V_{IH} overshoot: $V_{IH}(\text{MAX}) = V_{DDQ} + 2V$ for a pulse width $\leq 3\text{ ns}$, and the pulse width cannot be greater than one third of the cycle rate. V_{IL} undershoot: $V_{IL}(\text{MIN}) = -2V$ for a pulse width $\leq 3\text{ ns}$.
23. The clock frequency must remain constant (stable clock is defined as a signal cycling within timing constraints specified for the clock pin) during access or precharge states (READ, WRITE, including t_{WR} , and PRECHARGE commands). CKE may be used to reduce the data rate.
24. Auto precharge mode only. The precharge timing budget (t_{RP}) begins 7ns for -13E; 7.5ns for -133 and 7ns for -10E after the first clock delay, after the last WRITE is executed. May not exceed limit set for precharge mode.
25. Precharge mode only.
26. JEDEC and PC100 specify three clocks.
27. t_{AC} for -133/-13E at $CL = 3$ with no load is 4.6ns and is guaranteed by design.
28. Parameter guaranteed by design.
29. The value of t_{RAS} . use in -13E speed grade module SPDs is calculated from $t_{RC} - t_{RP} = 45\text{ ns}$.
30. For -10E, $CL = 2$ and $t_{CK} = 10\text{ ns}$; for -133, $CL = 3$ and $t_{CK} = 7.5\text{ ns}$; for -13E, $CL = 2$ and $t_{CK} = 7.5\text{ ns}$.
31. CKE is HIGH during refresh command period $t_{RFC}(\text{MIN})$ else CKE is LOW. The I_{DD6} limit is actually a nominal value and does not result in a fail value.
32. This AC timing function will show an extra clock cycle when in registered mode.
33. Leakage number reflects the worst case leakage possible through the module pin, not what each memory device contributes.

SPD Clock and Data Conventions

Data states on the SDA line can change only during SCL LOW. SDA state changes during SCL HIGH are reserved for indicating start and stop conditions (as shown in Figure 6, Data Validity, and Figure 7, Definition of Start and Stop).

SPD Start Condition

All commands are preceded by the start condition, which is a HIGH-to-LOW transition of SDA when SCL is HIGH. The SPD device continuously monitors the SDA and SCL lines for the start condition and will not respond to any command until this condition has been met.

SPD Stop Condition

All communications are terminated by a stop condition, which is a LOW-to-HIGH transition of SDA when SCL is HIGH. The stop condition is also used to place the SPD device into standby power mode.

SPD Acknowledge

Acknowledge is a software convention used to indicate successful data transfers. The transmitting device, either master or slave, will release the bus after transmitting eight bits. During the ninth clock cycle, the receiver will pull the SDA line LOW to acknowledge that it received the eight bits of data (as shown in Figure 8, Acknowledge Response from Receiver).

The SPD device will always respond with an acknowledge after recognition of a start condition and its slave address. If both the device and a write operation have been selected, the SPD device will respond with an acknowledge after the receipt of each subsequent eight-bit word. In the read mode the SPD device will transmit eight bits of data, release the SDA line and monitor the line for an acknowledge. If an acknowledge is detected and no stop condition is generated by the master, the slave will continue to transmit data. If an acknowledge is not detected, the slave will terminate further data transmissions and await the stop condition to return to standby power mode.

Figure 6: Data Validity

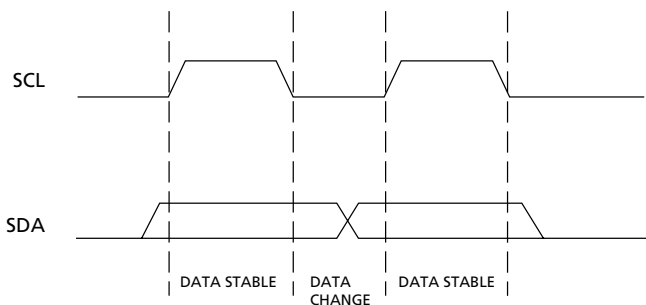

Figure 7: Definition of Start and Stop

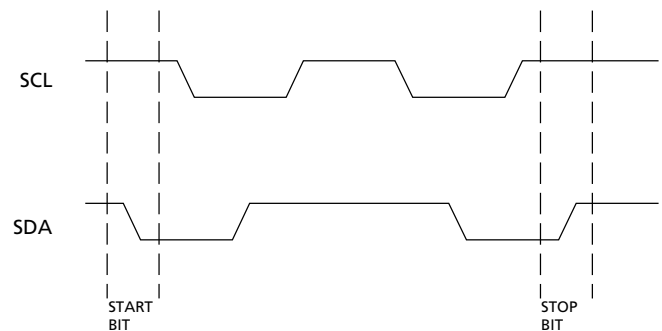

Figure 8: Acknowledge Response from Receiver

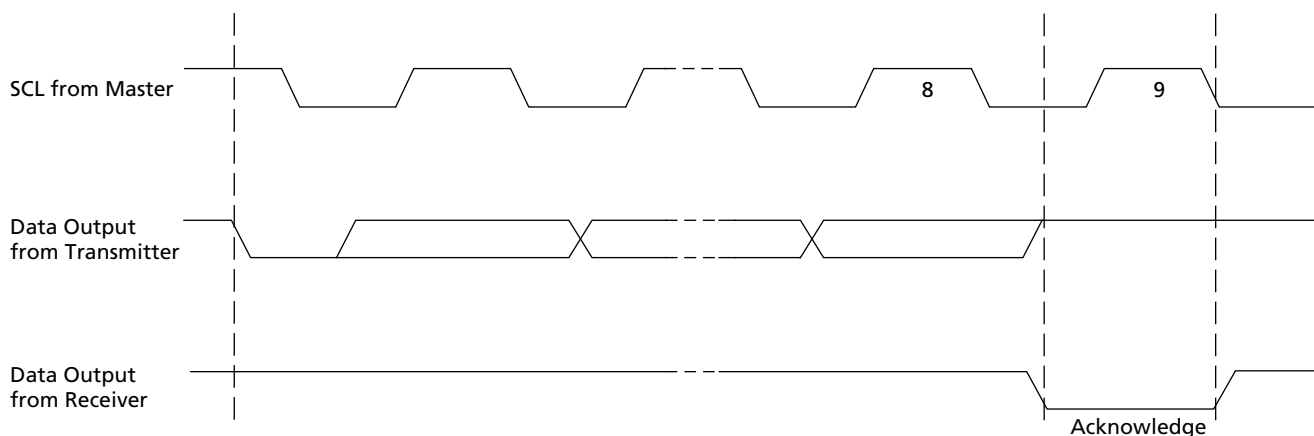

Table 17: EEPROM Device Select Code

Most significant bit (b7) is sent first

SELECT CODE	DEVICE TYPE IDENTIFIER					CHIP ENABLE		\overline{RW}
	b7	b6	b5	b4	b3	b2	b1	b0
Memory Area Select Code (Two Arrays)	1	0	1	0	SA2	SA1	SA0	\overline{RW}
Protection Register Select Code	0	1	1	0	SA2	SA1	SA0	\overline{RW}

Table 18: EEPROM Operating Modes

MODE	RW BIT	\overline{WC}	BYTES	INITIAL SEQUENCE
Current Address Read	1	V _{IH} or V _{IL}	1	Start, Device Select, $\overline{RW} = 1$
Random Address Read	0	V _{IH} or V _{IL}	1	Start, Device Select, $\overline{RW} = 0$, Address
	1	V _{IH} or V _{IL}		Restart, Device Select, $\overline{RW} = 1$
Sequential Read	1	V _{IH} or V _{IL}	≥ 1	Similar to Current or Random Address Read
Byte Write	0	V _{IL}	1	Start, Device Select, $\overline{RW} = 0$
Page Write	0	V _{IL}	≤ 16	Start, Device Select, $\overline{RW} = 0$

Figure 9: SPD EEPROM Timing Diagram

Table 19: Serial Presence-Detect EEPROM DC Operating Conditions

 All voltages referenced to V_{SS}; V_{DD} = +3.3V ±0.3V

PARAMETER/CONDITION	SYMBOL	MIN	MAX	UNITS
SUPPLY VOLTAGE	V _{DD}	3	3.6	V
INPUT HIGH VOLTAGE: Logic 1; All inputs	V _{IH}	V _{DD} x 0.7	V _{DD} + 0.5	V
INPUT LOW VOLTAGE: Logic 0; All inputs	V _{IL}	-1	V _{DD} x 0.3	V
OUTPUT LOW VOLTAGE: I _{OUT} = 3mA	V _{OL}	-	0.4	V
INPUT LEAKAGE CURRENT: V _{IN} = GND to V _{DD}	I _{LI}	-	10	μA
OUTPUT LEAKAGE CURRENT: V _{OUT} = GND to V _{DD}	I _{LO}	-	10	μA
STANDBY CURRENT: SCL = SDA = V _{DD} - 0.3V; All other inputs = V _{SS} or V _{DD}	I _{SB}	-	30	μA
POWER SUPPLY CURRENT: SCL clock frequency = 100 KHz	I _{DD}	-	2	mA

Table 20: Serial Presence-Detect EEPROM AC Operating Conditions

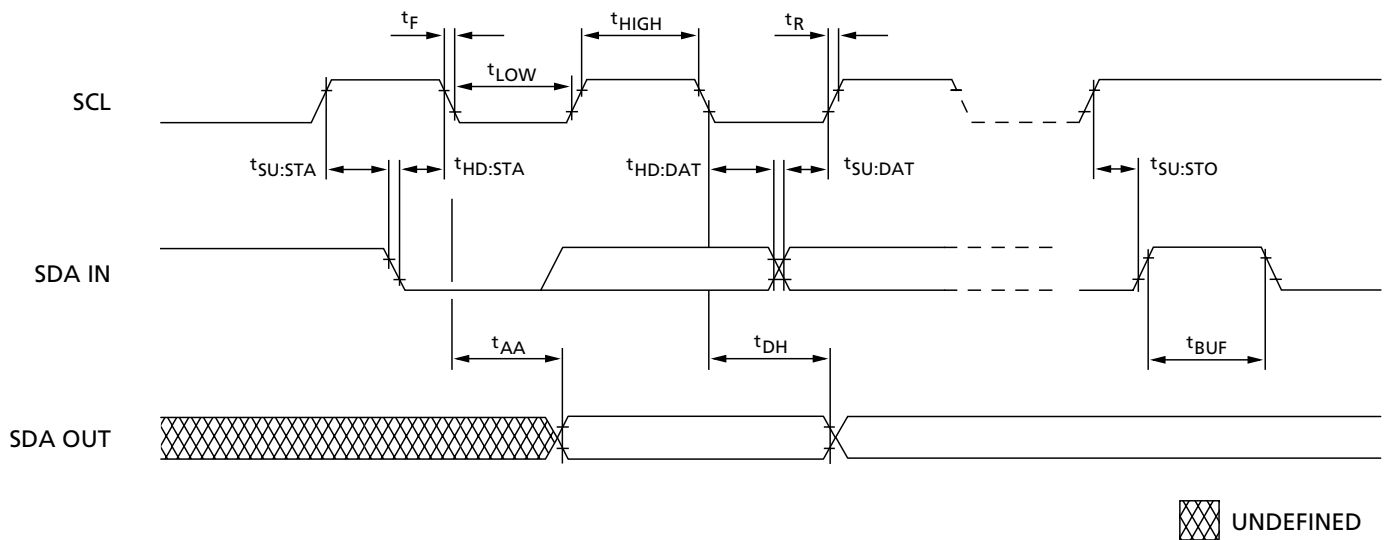
 All voltages referenced to V_{SS}; V_{DD} = +3.3V ±0.3V

PARAMETER/CONDITION	SYMBOL	MIN	MAX	UNITS	NOTES
SCL LOW to SDA data-out valid	t _{AA}	0.3	3.5	μs	
Time the bus must be free before a new transition can start	t _{BUF}	4.7		μs	
Data-out hold time	t _{DH}	300		ns	
SDA and SCL fall time	t _F		300	ns	
Data-in hold time	t _{HD:DAT}	0		μs	
Start condition hold time	t _{HD:STA}	4		μs	
Clock HIGH period	t _{HIGH}	4		μs	
Noise suppression time constant at SCL, SDA inputs	t _I		100	ns	
Clock LOW period	t _{LOW}	4.7		μs	
SDA and SCL rise time	t _R		1	μs	
SCL clock frequency	t _{SCL}		100	KHz	
Data-in setup time	t _{SU:DAT}	250		ns	
Start condition setup time	t _{SU:STA}	4.7		μs	
Stop condition setup time	t _{SU:STO}	4.7		μs	
WRITE cycle time	t _{WRC}		10	ms	1

NOTE:

1. The SPD EEPROM WRITE cycle time (t_{WRC}) is the time from a valid stop condition of a write sequence to the end of the EEPROM internal erase/program cycle. During the WRITE cycle, the EEPROM bus interface circuit is disabled, SDA remains HIGH due to pull-up resistor, and the EEPROM does not respond to its slave address.

Table 21: Serial Presence- Detect Matrix

"1"/"0": Serial Data, "driven to HIGH"/"driven to LOW"

BYTE	DESCRIPTION	ENTRY (VERSION)	MT18LSDT1672G	MT18LSDT3272G	MT18LSDT6472G
0	Number of Bytes Used By Micron	128	80	80	80
1	Total Number of SPD Memory Bytes	256	08	08	08
2	Memory Type	SDRAM	04	04	04
3	Number of Row Addresses	12or13	0C	0C	0D
4	Number of Column Addresses	10or11	0A	0B	0B
5	Number of Module Ranks	1	01	01	01
6	Module Data Width	72	48	48	48
7	Module Data Width (Continued)	0	00	00	00
8	Module Voltage Interface Levels	LVTTL	01	01	01
9	SDRAM Cycle Time, ^t CK (CAS Latency = 3)	7 (-13E) 7.5 (-133) 8 (-10E)	70 75 80	70 75 80	70 75 80
10	SDRAM Access From Clock, ^t AC (CAS Latency = 3)	5.4 (-13E/-133) 6 (-10E)	54 60	54 60	54 60
11	Module Configuration Type	ECC	02	02	02
12	Refresh Rate/type	7.8/15.6μs/SELF	80	80	82
13	SDRAM Width (Primary SDRAM)	4	04	04	04
14	Error-Checking SDRAM Data Width	4	04	04	04
15	Minimum Clock Delay, ^t CCD	1	01	01	01
16	Burst Lengths Supported	1, 2, 4, 8, PAGE	8F	8F	8F
17	Number of Banks on SDRAM Device	4	04	04	04
18	CAS Latencies Supported	2, 3	06	06	06
19	CS Latency	0	01	01	01
20	WE Latency	0	01	01	01
21	SDRAM Module Attributes	-133	1F	1F	1F
22	SDRAM Device Attributes: General	0E	0E	0E	0E
23	SDRAM Cycle Time, ^t CK (CAS Latency = 2)	7.5 (-13E) 10 (-133/-10E)	75 A0	75 A0	75 A0
24	SDRAM Access From Clock, ^t AC, (CAS Latency = 2)	5.4 (-13E) 6 (-133/-10E)	54 60	54 60	54 60
25	SDRAM Cycle Time, ^t CK (CAS Latency = 1)	–	00	00	00
26	SDRAM Access From Clock, ^t AC, (CAS Latency = 1)	–	00	00	00
27	Minimum Row Precharge Time, ^t RP	15 (-13E) 20 (-133/-10E)	0F 14	0F 14	0F 14
28	Minimum Row Active to Row Active, ^t R RD	14(-13E) 15 (-133) 20 (-10E)	0E 0F 14	0E 0F 14	0E 0F 14
29	Minimum RAS# to CAS# Delay, ^t R CD	15 (-13E) 20 (-133/-10E)	0F 14	0F 14	0F 14
30	Minimum RAS# Pulse Width, ^t R AS (See note 1)	45 (-13E) 44 (-133) 50 (-10E)	2D 2C 32	2D 2C 32	2D 2C 32
31	Module Rank Density	128MB/ 256MB/512MB	20	40	80

Table 21: Serial Presence- Detect Matrix (Continued)

"1"/"0": Serial Data, "driven to HIGH"/"driven to LOW"

BYTE	DESCRIPTION	ENTRY (VERSION)	MT18LSDT1672G	MT18LSDT3272G	MT18LSDT6472G
32	Command Address Setup, ^t AS	1.5 (-13E/-133) 2 (-10E)	15 20	15 20	15 20
33	Command Address Hold, ^t AH	0.8 (--13E/133) 1 (-10E)	08 10	08 10	08 10
34	Data Signal Input Setup, ^t DS	1.5 (-13E/-133) 2 (-10E)	15 20	15 20	15 20
35	Data Signal Input Hold, ^t DH	0.8 (-13E/-133) 1 (-10E)	08 10	08 10	08 10
36-61	Reserved Bytes		00	00	00
62	SPD Revision	REV. 1.2	12	12	12
63	Checksum For Bytes 0-62	-13E -133 -10E	91 D7 1F	B2 F8 40	F5 3B 83
64	Manufacturer's JEDEC ID Code	MICRON	2C	2C	2C
65-71	Manufacturer's JEDEC Code (Cont.)		FF	FF	FF
72	Manufacturing Location		01-11	01-0B	01-0B
73-90	Module Part Number (ASCII)		Variable Data	Variable Data	Variable Data
91	PCB Identification Code	1-9	01-09	01-09	01-09
92	Identification Code (Continued)	0	00	00	00
93	Year of Manufacture in BCD		Variable Data	Variable Data	Variable Data
94	Week of Manufacture in BCD		Variable Data	Variable Data	Variable Data
95-98	Module Serial Number		Variable Data	Variable Data	Variable Data
99-125	Manufacturer-Specific Data (Rsvd)		-	-	-
126	Identification Code (Continued)	100/133 MHz	64	64	64
127	Year of Manufacture in BCD		8F	8F	8F

NOTE:

- The value of ^tRAS used for the -13E module is calculated from ^tRC - ^tRP. Actual device spec. value is 37 ns.

Figure 10: 168-Pin DIMM Dimensions (Standard PCB)

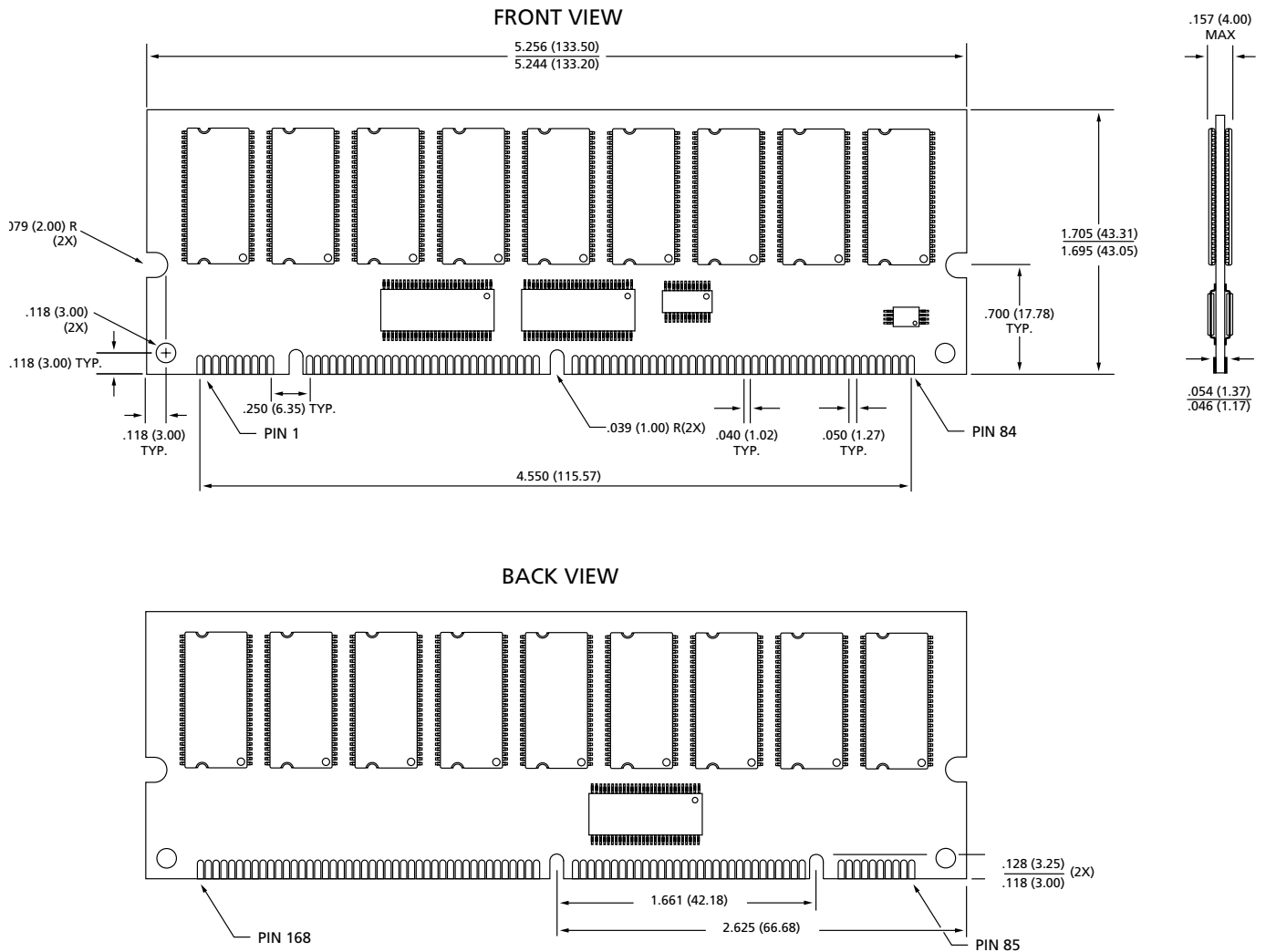

NOTE:

All dimensions in inches (millimeters) $\frac{MAX}{MIN}$ or typical where noted.

Figure 11: 168-Pin DIMM Dimensions (Low-Profile PCB)

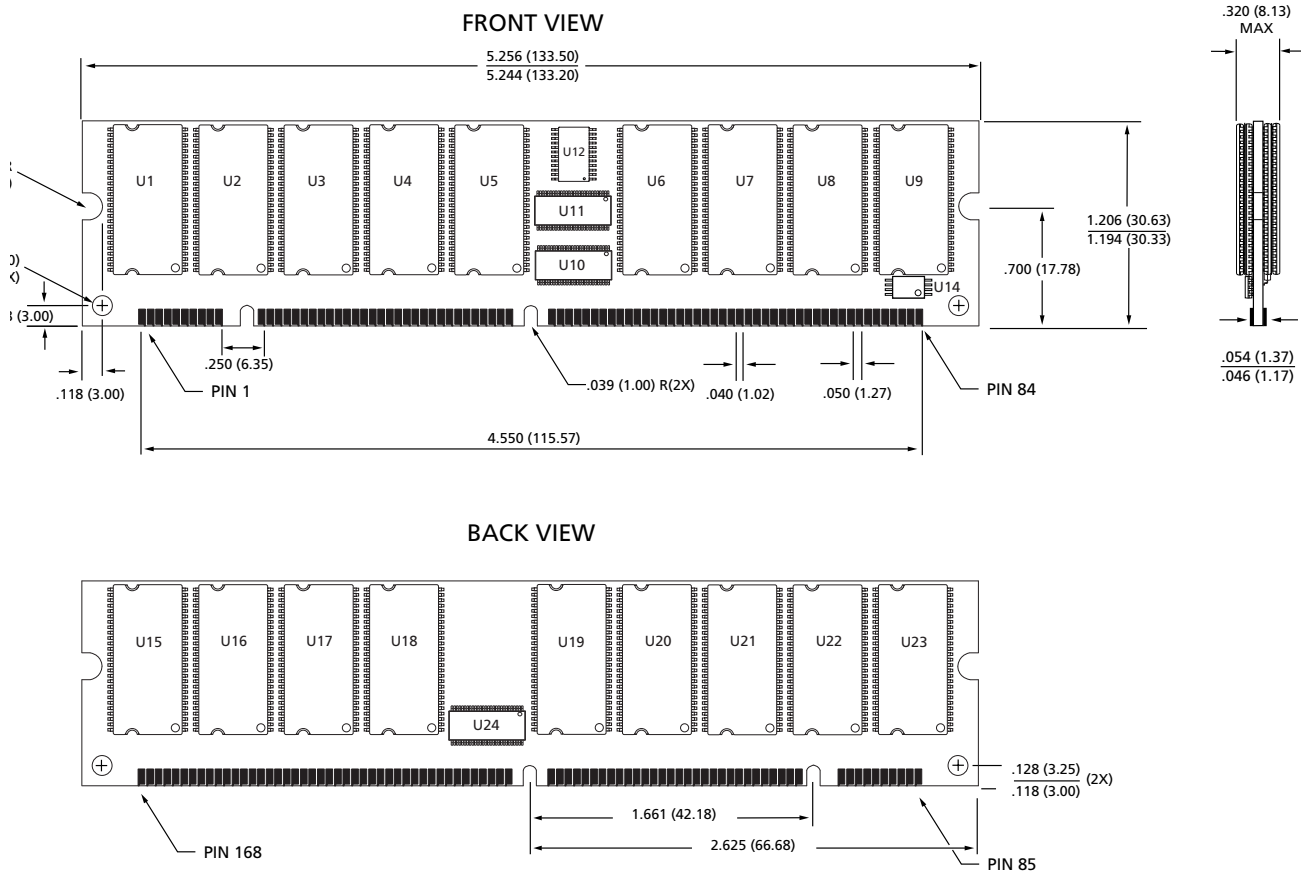

NOTE:

All dimensions in inches (millimeters) $\frac{MAX}{MIN}$ or typical where noted.

Data Sheet Designation

Released (No Mark): This data sheet contains minimum and maximum limits specified over the complete power supply and temperature range for production

devices. Although considered final, these specifications are subject to change, as further product development and data characterization sometimes occur.



**128MB, 256MB, 512MB (x72, ECC)
168-PIN REGISTERED SDRAM DIMM**



8000 S. Federal Way, P.O. Box 6, Boise, ID 83707-0006, Tel: 208-368-3900

E-mail: prodmtg@micron.com, Internet: <http://www.micron.com>, Customer Comment Line: 800-932-4992

Micron, the M logo, and the Micron logo are trademarks and/or service marks of Micron Technology, Inc.