

SanDisk uSSD™ 5000 Solid State Drive

Product Manual

Revision 0.3

April 2007



SanDisk Corporation

Corporate Headquarters • 601 McCarthy Blvd. • Milpitas, CA 95035

Phone (408) 801-1000 • Fax (408) 801-8657

www.sandisk.com

Table of Contents

1. Introduction	3
1.1 General Description.....	3
1.1.1 Applications	3
1.1.2 Rugged and Reliable.....	3
1.1.3 High Performance	3
1.1.4 Cost Effective	3
1.2 Features.....	4
1.3 Scope	5
1.3.1 Technology Independence.....	5
1.3.2 Defect and Error Management	5
1.3.3 Wear-leveling	5
1.3.4 Bad Block Management.....	5
2. Product Specifications	6
2.1 Formatted Capacities.....	6
2.2 System Environmental Specifications	6
2.3 System Power Requirements	7
2.4 System Performance	7
2.5 System Reliability	7
2.5.1 MTTF	8
2.6 Endurance	9
2.7 Electrical Interface.....	9
2.7.1 uSSD Connector	9
2.7.2 Electrical Specifications.....	10
2.8 Physical Specifications	11
2.8.1 uSSD-to-USB Adapter.....	12
2.9 Product Markings and Traceability	12
2.10 OS Support	13
2.11 Regulatory Compliance	13
Appendix A. Ordering Information	14
Appendix B. Limited Warranty	15
Appendix C. Disclaimer of Liability	17

List of Tables

Table 1: Formatted Capacities	6
Table 2: Environmental Specifications	6
Table 3: Power Requirements.....	7
Table 4: Performance.....	7
Table 5: Reliability.....	8
Table 6: uSSD MTTF	8
Table 7: Endurance.....	9
Table 8: Host Interface 2x5 On-Board Header	9
Table 9: Absolute Maximum Ratings.....	10
Table 10: DC Characteristics for Full-Speed Operation (TA = 25°C)	10
Table 11: DC Characteristics for High-Speed Operation (TA = 25°C)	10
Table 12: Physical Dimensions	11
Table 13: OS Support	13
Table 14: Ordering Information	14

1. Introduction

1.1 General Description

The SanDisk uSSD™ 5000 Solid State Drive (uSSD) takes the benefits of flash storage to new markets with low-capacity storage requirements, most notably the low-cost PC (LCPC). Rugged and reliable, it is a fraction of the size and cost of a hard disk drive (HDD) in the 1 to 8 GB range. SanDisk adds high performance to the uSSD offering, with an advanced controller that exemplifies the company's years of USB expertise.

1.1.1 Applications

The SanDisk uSSD offers a no-compromise flash-based storage solution for:

- LCPCs that need rugged reliability and require up to 4 GB storage. The uSSD can meet these requirements more cost-effectively than an HDD.
- Desktops that support Microsoft® Vista and can benefit from enabling ReadyBoost®.
- Point of sale (POS) stations, where the uSSD replaces the HDD.
- Blade servers, where the uSSD is ideal to store critical backup files and provide boot functionality.

1.1.2 Rugged and Reliable

Unlike the HDD, the SanDisk uSSD has no moving parts. It keeps working in challenging environments such as classrooms, kiosks and in space-restricted server racks. The patented flash management technology brings top data integrity to the uSSD, even during power losses. Dynamic bad block management, dynamic and static wear-leveling, and robust error detection and correction code (EDC/ECC) ensure data reliability.

1.1.3 High Performance

The uSSD achieves a sustained read speed as high as 31.6 MB/sec and a sustained write speed of up to 24.8 MB/sec with single-level cell (SLC) technology.

1.1.4 Cost Effective

There is no need to pay for more capacity than you require. The uSSD lets you purchase just the right amount of storage, packed inside a memory device that's 4 times smaller than a 1.8" HDD. It offers you the choice of single-level cell (SLC) flash technology or the more cost-effective multi-level cell (MLC) technology.

1.2 Features

The SanDisk uSSD 5000 provides the following system features:

- Non-volatile storage (no battery required)
- USB 2.0 interface, certified by the USB organization
- Complies with Microsoft Vista ReadyBoost® requirements
- Up to 8 GB of mass storage based on SanDisk's reliable flash technology
- SLC flash and MLC flash-based configurations
- Fixed configuration (not removable)
- Low power consumption
- High performance:
 - Sustained Read and write speed of up to 31.6 MB/sec for reading, 24.8 MB/sec for writing (SLC configuration)
- Rugged
- Lightweight
- Silent
- Standard and low profile
- Advanced error detection and error correction algorithms
- Advanced wear-leveling algorithms
- Guaranteed data integrity even after power loss
- MTTF* > 4,000,000 hours
- Multiple OS support
- Warranty: 3 years

* Based on internal testing. The MTTF calculation does not take into account the disk endurance limitation. For the disk endurance, please refer to the endurance section on page 9.

1.3 Scope

This document describes the key features and specifications of the uSSD 5000, as well as the information required to interface this product to a host system.

1.3.1 Technology Independence

To write or read a sector (or multiple sectors), the host computer software simply issues a Read or Write command to the module.

This command contains the address and the number of sectors to write/read. The host software then waits for the command to be completed.

The host software does not participate in the details of how the flash memory is erased, programmed or read. This is extremely important as flash devices are expected to increase in complexity in the future. Because the uSSD 5000 uses an intelligent on-board controller, the host system software will not need to be changed as new flash memory evolves. As such, systems that support uSSD 5000 now will be able to access future SanDisk Modules built with new flash technology without any need to update or change the host software.

1.3.2 Defect and Error Management

The uSSD 5000 contains a sophisticated defect and error management system.

If necessary, the Module will rewrite data from a defective sector to a good sector. This is completely transparent to the host and does not consume any user data space.

The uSSD 5000 soft error rate specification is much better than the magnetic disk drive specification.

In the extremely rare case that a read error does occur, the uSSD 5000 has innovative algorithms to recover the data by using hardware on-the-fly Error Detection Code/Error Correction Code (EDC/ECC), based on a BCH algorithm.

These defect and error management systems, coupled with solid state construction, give the SanDisk uSSD 5000 unparalleled reliability.

1.3.3 Wear-leveling

Wear-leveling is an inherent part of the erase-pooling functionality of the SanDisk uSSD 5000, using NAND memory.

Advanced features of dynamic and static wear-leveling and automatic block management are used to ensure high data reliability and maximize flash life expectancy.

1.3.4 Bad Block Management

Bad blocks are occasionally created during the lifecycle of a flash component, in a phenomenon called dynamic bad block accumulation. These bad blocks must be dynamically marked and replaced to prevent read/write failures.

When a bad block is detected, the embedded bad block mapping algorithm maps out the block, which is then no longer used for storage.

2. Product Specifications

For all the following specifications, unless otherwise stated, values are defined at ambient temperature and nominal supply voltage.

2.1 Formatted Capacities

Table 1 shows the formatted capacities for the uSSD 5000:

Table 1: Formatted Capacities

Capacity [GB]	Capacity (formatted in bytes)	Sectors/Module (Max. LBA+1)	No. of Heads	No. of Sectors/Track	No. of Cylinders
SLC Configurations					
1	1024967168	2001889			
2	2048901632	4001761			
4	4110189056	8027713			
8	TBD	TBD			
MLC Configurations					
2	2048901632	4001761			
4	4110189056	8027713			
8	TBD	TBD			

2.2 System Environmental Specifications

Table 2 lists the environmental specifications, including temperature, noise level, vibration, shock and altitude.

Table 2: Environmental Specifications

Specification	Parameters
Temperature	Operating (Commercial): 0° C to 70° C Storage temp without user data retention: -40° C to 85° C Storage temp with user data retention: 0° C to 70° C
Noise Level	0 dB
Vibration	Operating: 2.17gRMS (20Hz to 2000Hz, 3 vibration axes, 60 min) Non operating: 3.08 gRMS (20 Hz to 2000 Hz)
Shock	Operating: 50 g, 11 msec duration, half sine Non operating: 1,500 g, 0.5 msec duration, half sine
Altitude (relative to sea level)	80,000 ft. maximum
ESD	Contact discharge: Up to 4 KV (enclosed in a host) Air discharge: Up to 8 KV (enclosed in a host)
Flammability ratings for major components	PCB: 888-1 94V0 HK ASIC Packaging materials: TBD Flash packaging materials: TBD Labels: CM-100-SM, CM-200-WS

2.3 System Power Requirements

All values quoted in Table 3 are typical at 25° C and nominal supply voltage unless otherwise stated.

are typical at 25° C and nominal supply voltage unless otherwise stated.

Table 3: Power Requirements

Power Mode	5V +/- 10% IDD
Standby	2.5 mA
Operating HS Read	150 mA
Operating HS Write	150 mA
Idle HS	100 mA

2.4 System Performance

Table 4 lists the performance parameters of the SLC and MLC flash-based configurations:

Table 4: Performance

Specification	Parameters
Maximum performance for capacity of 1 GB (SLC flash configuration)	
Sequential Read	31.6 MB/sec
Sequential Write	24.8 MB/sec
Random Read	TBD
Random Write	TBD
Maximum performance for 2 GB, 4 GB and 8 GB (SLC flash configurations)	
Sequential Read	31.6 MB/sec
Sequential Write	24.8 MB/sec
Random Read @ 4KB access	5.7 MB/sec
Random Write @ 4KB access	1.2 MB/sec
Maximum performance 2 GB, 4 GB and 8 GB (MLC configuration)	
Sequential Read	29.9 MB/sec
Sequential Write	12.8 - 9.0 MB/sec (based on capacity)
Random Read	TBD
Random Write	TBD
Host compatibility	
USB 2.0	Up to 60 MB/sec

Note: Benchmark performed using HD Bench on Windows 2000 and Winsat on Microsoft Windows Vista

2.5 System Reliability

Table 5: Reliability

Specification	Parameters
Data Reliability	Error detection / error correction based on BCH algorithm
Data integrity after power loss	Data is guaranteed after power loss
Bad blocks	Transparent bad block management
Wear-leveling	Dynamic and Static Wear-leveling

2.5.1 MTTF

The reliability figure of merit most often used for electronic equipment is Mean Time To Failure (MTTF). SanDisk estimates MTTF using a prediction methodology based on reliability data for the individual components in SanDisk products.

Component data comes from several sources: device life tests, failure analysis of earlier equipment, device physics, and field returns.

SanDisk uses following methods to predict reliability:

- Telcordia Special Report SR-332, Reliability Prediction Procedure for Electronic Equipment (RPP).
- British Telecom Industry HRD5, Handbook of Reliability Data for Electronic Components used in Telecommunication System.

Table 6 summarizes the MTTF prediction results for various uSSD configurations. The analysis was performed using a RAM Commander™ failure rate prediction.

- **Failure Rate:** The total number of failures within an item population, divided by the total number of life units expended by that population, during a particular measurement interval under stated condition.
- **Mean Time To Failures (MTTF):** A basic measure of reliability for repairable items: The mean number of life units during which all parts of the item perform within their specified limits, during a particular measurement interval under stated conditions.

Table 6: uSSD MTTF

Product	Condition	MTTF (Hours)
1GB, 2GB, 4GB	Telcordia SR-332, GB, 25°C	4M
8GB	Telcordia SR-332, GB, 25°C	3M

2.6 Endurance

Table 7 lists the maximum number of GBs that can be written to the uSSD 5000 per day per the SLC and MLC flash-based configurations.

The numbers are derived from the flash capabilities and the 3 year warranty, which are provided for the product.

- **SLC flash based uSSD** - User can update the entire device 6 times a day during 3 years
- **MLC flash based uSSD** - User can update 25% of the device capacity every day during 3 years

Table 7: Endurance

Specification	SLC Flash-based uSSD	MLC Flash-based uSSD
1 GB	< 6 GB	-
2 GB	< 12 GB	< 512 MB
4 GB	< 24 GB	< 1 GB
8 GB	< 48 GB	< 2 GB

2.7 Electrical Interface

Table 8 lists the host interface on-board header pins and signals.

Table 8: Host Interface 2x5 On-Board Header

Pin	Signal	Pin	Signal
1	+5VDC	2	+5VDC
3	USB1 Data(-)	4	USB2 Data(-)
5	USB1 Data(+)	6	USB2 Data(+)
7	GND	8	GND
9	Key (no pin)	10	NC

2.7.1 uSSD Connector

Figure 1 illustrates the uSSD 2x5 device interface connector:

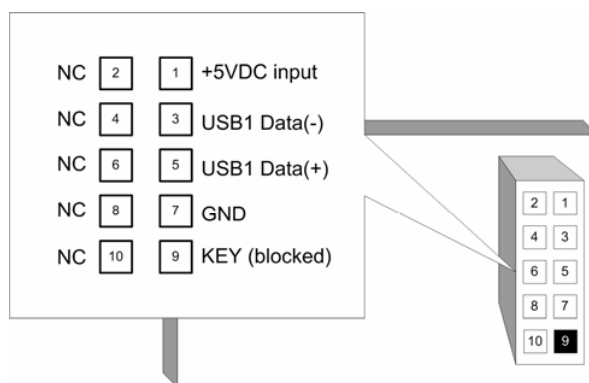

Figure 1: uSSD 2x5 Connector Pinout

2.7.2 Electrical Specifications

2.7.2.1 Absolute Maximum Ratings

Table 9: Absolute Maximum Ratings

Parameter	Symbol	Min	Max	Unit
Ambient Operating Temperature Range (Commercial)	T_A	0	70	°C
Power Supply Voltage Relative to Ground	V_{bus}	0	5.5	V
Voltage level on D+ / D- Relative to Ground 3	V_{data}	TBD	TBD	V

2.7.2.2 DC Characteristics

Table 10: DC Characteristics for Full-Speed Operation ($T_A = 25^\circ\text{C}$)

Parameter - USB Signals	Symbol	Min	Typ	Max	Unit
Supply Voltage:	V_{BUS}	4.5	5.0	5.5	V
Supply Current (RMS):					
Operating	I_{cc}	-	120	150	mA
Suspend	I_{ccs}	-	1.2	2.5	μA
Max Current Consumption (Peak Value)		-	-	150	mA
Input Levels USB Signals (D+, D-):					
Low	V_{IL}	-	-	0.8	V
High	V_{IH}	2.0	-	-	V
Output Voltage USB Signals (D+, D-):					
Low	V_{OL}	0.0	-	0.3	V
High	V_{OH}	2.8	-	3.6	V
Output Signal Crossover Voltage USB Signals (D+, D-)	V_{CRS}	1.3	-	2.0	V

Table 11: DC Characteristics for High-Speed Operation ($T_A = 25^\circ\text{C}$)

Parameter - USB Signals	Symbol	Min	Typ	Max	Unit
Supply Voltage:	V_{BUS}	4.5	5.0	5.5	V
Supply Current (RMS)					
Operating	I_{cc}	-	100	100	mA
Suspend	I_{ccs}	-	1.2	2.5	μA
Max Current Consumption (Peak Value)		-	-	100	mA
Input Levels USB Signals (D+, D-):					
Low	V_{IL}				V
High	V_{IH}				V
Output Voltage USB Signals (D+, D-):					
Low	V_{OL}	-10		10	V
High	V_{OH}	360		440	V
Output Signal Crossover Voltage USB Signals (D+, D-):	V_{CRS}	TBD	TBD	TBD	V

2.8 Physical Specifications

SanDisk offers the uSSD 5000 in 2 form factors:

- Standard profile
- Low profile

Table 12 and Figure 2, Figure 3 and Figure 4 list the physical specifications and dimensions of the uSSD 5000.

Table 12: Physical Dimensions

Dimension	Parameters
Weight	4.9g
Length	Standard and Low Profile: 37.80 ± 0.25 mm
Width	Standard and Low Profile: 26.65 ± 0.25 mm
Thickness	Standard profile: 10.60 ± 0.25 mm Low Profile: 6.58 ± 0.25 mm

2.8.1 Standard Configuration

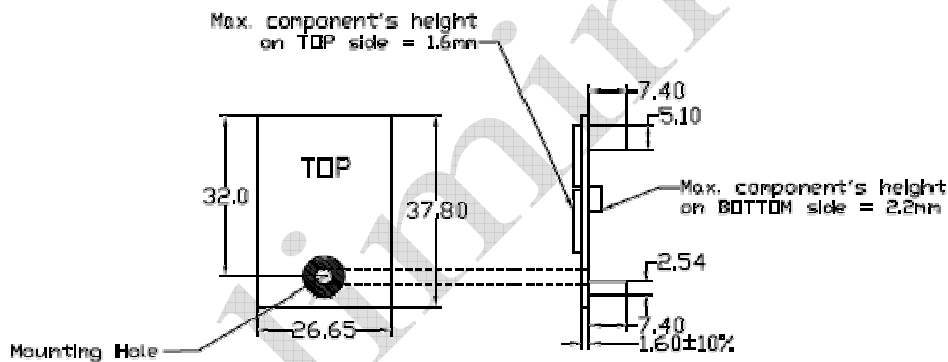

Figure 2: uSSD Standard Version, Top View

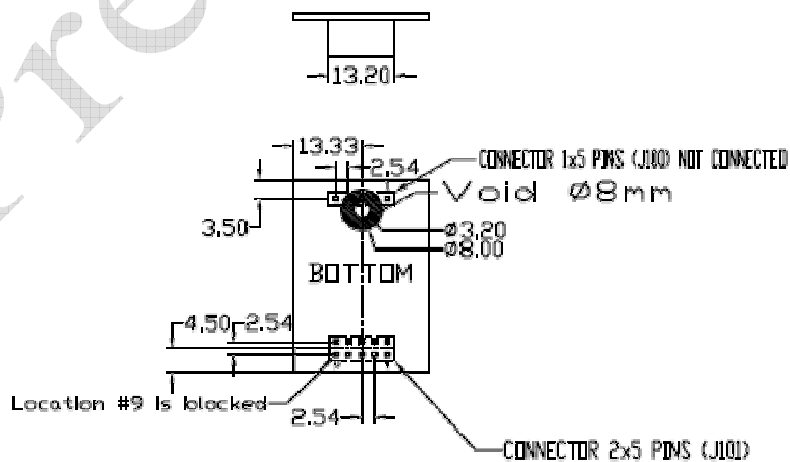

Figure 3: uSSD Standard Version, Bottom View

2.8.2 Low Profile Configuration

SIDE VIEW

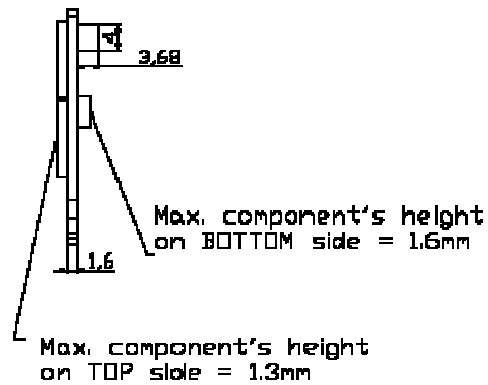

Figure 4: uSSD 2x5 Low Profile Version

2.8.3 uSSD-to-USB Adapter

An adapter is available to assist customers in evaluating the uSSD 5000. The adapter enables inserting the uSSD 5000 in an external desktop or laptop USB port.



Figure 5: uSSD External USB Adapter

2.9 Product Markings and Traceability

To be added

2.10 OS Support

The uSSD 5000 is supported under the operating systems listed in Table 13. In the standard boot and storage modes, the uSSD 5000 is recognized as a fixed disk in the system. The system can also boot from the uSSD 5000, eliminating the need for additional components.

Software packages for the supported operating systems can be downloaded from the SanDisk website, along with the relevant documentation.

Table 13: OS Support

Operating System	Version	Support
Windows XP Pro	Service Pack 2	SanDisk driver
Windows XP Embedded	FP 2008	Native in the OS
Windows Vista (Storage and ReadyBoost support)		Native in the OS
Windows Embedded for Point of Service (WEPOS)	N/A	SanDisk driver
Windows Server 2003		SanDisk driver
Windows CE	5.0 and 6.0	Native in the OS
Linux	All versions	Native in the OS
DOS		Native in the OS

2.11 Regulatory Compliance

The uSSD 5000 complies with the following:

- USB Organization certification
- RoHS (6 Materials)
- Chinese RoHS
- FCC Class B for Information Technology
- CE EN 55022/55024
- Flammability ratings for major components can be found under System Environmental Specifications on page 6.
- WHQL
- Windows Vista ReadyBoost® compliance

Appendix A. Ordering Information

Table 14: Ordering Information

SKU	Capacity	Horizontal	Low Profile	Internal Led	External Led	MLC	Binary
SDUS5AB-001G	1GB	X		X			X
SDUS5EB-001G	1GB		X	X			X
SDUS5FB-001G-1036	1GB		X		X		X
SDUS5AB-002G	2GB	X		X			X
SDUS5AJ-002G	2GB	X		X		X	
SDUS5EB-002G	2GB		X	X			X
SDUS5EJ-002G	2GB		X	X		X	
SDUS5FB-002G-1036	2GB		X		X		X
SDUS5FJ-002G-1036	2GB		X		X	X	
SDUS5AB-004G	4GB	X		X			X
SDUS5AB-004G-1035	4GB	X		X			X
SDUS5AJ-004G	4GB	X		X		X	
SDUS5EB-004G	4GB		X	X			X
SDUS5EJ-004G	4GB		X	X		X	
SDUS5AB-008G	8GB	X		X			X
SDUS5AB-008G-1035	8GB	X		X			X
SDUS5AJ-008G	8GB	X		X		X	
SDUS5EB-008G	8GB		X	X			X
SDUS5EJ-008G	8GB		X	X		X	
SDUS5A-0000	Mechanical	X					
SDUS5E-0000	Mechanical		X				

1 megabyte (MB) = 1 million bytes; 1 gigabyte (GB) = 1 billion bytes. Some of the listed capacity is used for formatting and other functions, and thus is not available for data storage.

Appendix B. Limited Warranty

I. Warranty Statement

SanDisk warrants its products to be free of any defects in materials or workmanship that would prevent them from functioning properly for one year from the date of purchase. This express warranty is extended by SanDisk Corporation.

II. General Provisions

This warranty sets forth the full extent of SanDisk's responsibilities regarding the SanDisk Module. In satisfaction of its obligations hereunder, SanDisk, at its sole option, will repair, replace or refund the purchase price of the product.

NOTWITHSTANDING ANYTHING ELSE IN THIS LIMITED WARRANTY OR OTHERWISE, THE EXPRESS WARRANTIES AND OBLIGATIONS OF SELLER AS SET FORTH IN THIS LIMITED WARRANTY, ARE IN LIEU OF, AND BUYER EXPRESSLY WAIVES ALL OTHER OBLIGATIONS, GUARANTIES AND WARRANTIES OF ANY KIND, WHETHER EXPRESS OR IMPLIED, INCLUDING WITHOUT LIMITATION, ANY IMPLIED WARRANTY OF MERCHANTABILITY OR FITNESS FOR A PARTICULAR PURPOSE OR INFRINGEMENT, TOGETHER WITH ANY LIABILITY OF SELLER UNDER ANY CONTRACT, NEGLIGENCE, STRICT LIABILITY OR OTHER LEGAL OR EQUITABLE THEORY FOR LOSS OF USE, REVENUE, OR PROFIT OR OTHER INCIDENTAL OR CONSEQUENTIAL DAMAGES, INCLUDING WITHOUT LIMITATION PHYSICAL INJURY OR DEATH, PROPERTY DAMAGE, LOST DATA, OR COSTS OF PROCUREMENT OF SUBSTITUTE GOODS, TECHNOLOGY OR SERVICES.

IN NO EVENT SHALL THE SELLER BE LIABLE FOR DAMAGES IN EXCESS OF THE PURCHASE PRICE OF THE PRODUCT, ARISING OUT OF THE USE OR INABILITY TO USE SUCH PRODUCT, TO THE FULL EXTENT SUCH MAY BE DISCLAIMED BY LAW.

SanDisk's products are not warranted to operate without failure. Accordingly, in any use of products in life support systems or other applications where failure could cause injury or loss of life, the products should only be incorporated in systems designed with appropriate redundancy, fault tolerant or back-up features.

III. What this Warranty Covers

For products found to be defective within five years of purchase, SanDisk will have the option of repairing or replacing the defective product, if the following conditions are met:

- A. A warranty registration Module for each defective product was submitted and is on file at SanDisk. If not, a warranty registration Module must accompany each returned defective product.

This Module is included in each product's original retail package.

- B. The defective product is returned to SanDisk for failure analysis as soon as possible after the failure occurs.
- C. An incident Module filled out by the user, explaining the conditions of usage and the nature of the failure, accompanies each returned defective product.
- D. No evidence is found of abuse or operation of products not in accordance with the published specifications, or of exceeding storage or maximum ratings or operating conditions.

All failing products returned to SanDisk under the provisions of this limited warranty shall be tested to the product's functional and performance specifications.

Upon confirmation of failure, each product will be analyzed, by whatever means necessary, to determine the root cause of failure. If the root cause of failure is found to be not covered by the above provisions, then the product will be returned to the customer with a report indicating why the failure was not covered under the warranty.

This warranty does not cover defects, malfunctions, performance failures or damages to the unit resulting from use in other than its normal and customary manner, misuse, accident or neglect; or improper alterations or repairs.

SanDisk reserves the right to repair or replace, at its discretion, any product returned by its customers, even if such product is not covered under warranty, but is under no obligation to do so.

SanDisk may, at its discretion, ship repaired or rebuilt products identified in the same way as new products, provided such Modules meet or exceed the same published specifications as new products. Concurrently, SanDisk also reserves the right to market any products, whether new, repaired, or rebuilt, under different specifications and product designations if such products do not meet the original product's specifications.

IV. Receiving Warranty Service

According to SanDisk's warranty procedure, defective product should be returned only with prior authorization from SanDisk Corporation. Please contact SanDisk's OEM Support Department at 866-436-6073 with the following information: product model number and description, serial numbers, nature of defect, conditions of use, proof of purchase and purchase date. If approved, SanDisk will issue a Return Material Authorization or Product Repair Authorization number and provide a shipping address where the defective product can be returned.

V. State Law Rights

SOME STATES DO NOT ALLOW THE EXCLUSION OR LIMITATION OF INCIDENTAL OR CONSEQUENTIAL DAMAGES, OR LIMITATION ON HOW LONG AN IMPLIED WARRANTY LASTS, SO THE ABOVE LIMITATIONS OR EXCLUSIONS MAY NOT APPLY TO YOU.

This warranty gives you specific rights and you may also have other rights that vary from state to state.

Appendix C. Disclaimer of Liability

SanDisk Corporation Policy

SanDisk Corporation general policy does not recommend the use of its products in life support applications wherein a failure or malfunction of the product may directly threaten life or injury.

Accordingly, in any use of products in life support systems or other applications where failure could cause damage, injury or loss of life, the products should only be incorporated in systems designed with appropriate redundancy, fault tolerant or back-up features.

SanDisk shall not be liable for any loss, injury or damage caused by use of the Products in any of the following applications:

- Special applications such as military related equipment, nuclear reactor control, and aerospace
- Control devices for automotive vehicles, train, ship and traffic equipment
- Safety system for disaster prevention and crime prevention
- Medical-related equipment including medical measurement device