



128MB to 16GB
CompactFlash Card

www.stec-inc.com

SLCFxxx(G)M2PU(I)

Solid-State Memory Card
(No Moving Parts)

Capacity: 128MB - 16GB

CFA 4.1 and ATA-7 Compatible

ATA Transfer modes:

- UDMA 0-4, MWDMA 0-4,
PIO 0-6 (SLC Flash Type)

Supports TrueIDE and PC Card
Memory and I/O Modes

Form Factors:

- CompactFlash Type I
- CompactFlash Adapter

Guaranteed 2M Program/Erase
Cycles

Card Information Structure (CIS)
Programmed into Internal Memory

PC Card and Socket Services
Release 2.1 or later compatible

5V or 3.3V Power Supply

Commercial and Industrial
Operating Temperature Ranges
Available

Full Data-Path Protection with
built-in ECC Engine

10 Year Data Retention

RoHS-6 Compliant

General Description

STEC's MACH2 CompactFlash (CF) card is an extremely high-performance, multi-channel solution available in capacities from 128MB to 16GB using SLC NAND flash. The standard CompactFlash interface provides designers with a true plug-n-play storage device, allowing for short design cycles and fast time to market, while the extreme performance enables hard disk drive performance in a much smaller and more reliable design.

CompactFlash cards have quickly become the product of choice for applications requiring high reliability and high tolerance to shock, vibration, humidity, altitude, and temperature. Because the MACH2 CompactFlash uses NAND flash technology (e.g. no moving parts), it is more reliable and has much lower latency compared to a traditional hard disk drive and consumes far less power (approximately 1 watt compared to 12 watts for a standard 7200rpm ATA disk drive). With its small footprint, high capacity, and rugged design, the MACH2 CompactFlash is an ideal hard disk drive replacement or alternate storage solution in space-constrained applications or those requiring less capacity than available hard disk drives offer including blade servers and embedded PCs.

STEC's MACH2 CF Card is available in a CompactFlash Type I package and adheres to the latest industry compliance and regulatory standards including UL, FCC, RoHS, and the Compact Flash Association (CFA). Because the MACH2 CF incorporates a proprietary state-of-the-art flash memory controller, it that provides the greatest flexibility to customer-specific applications while supporting key flash management features resulting in the industry's highest reliability and endurance. Key features include:

- Full datapath protection with built-in 8-bit BCH ECC engine to detect and correct up to 8-bit errors per 512 Bytes of data
- Sophisticated bad block management and wear leveling algorithms dramatically enhance flash memory endurance
- Power-down data protection ensures data integrity in case of power loss
- Lifecycle management feature allows users to monitor the card's lifetime by monitoring the card's remaining spare blocks

STEC's MACH2 CF card offers the highest reliability and tolerance to shock, vibration, humidity, altitude, ESD, and temperature. The rugged industrial design combined with temperature testing and adherence to rigid JEDEC JESD22 standards ensures flawless execution in the harshest environments. In addition to custom hardware and firmware designs, STEC also offers value-added services including:

- Custom labeling and packaging
- Custom software imaging and ID strings
- Full BOM control and product change notification
- Total supply-chain management to ensure continuity of supply
- In-field application engineering to help customers through product design-ins

Table of Contents

1.0 Ordering Information..... 3

2.0 Product Specifications..... 4

2.1 Labeling 4

2.2 Package Dimensions and Pin Locations 5

2.3 Pin Assignments..... 6

2.4 Signal Description..... 7

2.5 Performance..... 12

2.6 LBA and CHS Parameters..... 12

2.7 Standards Compliance 13

2.7.1 CE and FCC Class B & D 13

2.7.2 RoHS..... 13

3.0 Environmental Specifications..... 14

3.1 Recommended Operating Conditions 14

3.2 Reliability 14

3.3 Shock, Vibration, and Humidity 14

4.0 Electrical Specifications 15

4.1 Absolute Maximum Ratings..... 15

4.2 DC Characteristics..... 15

4.3 AC Characteristics..... 16

4.3.1 PC Card Memory Mode Attribute Memory Read 16

4.3.2 PC Card Memory Mode Attribute Memory Write 17

4.3.3 PC Card Memory Mode Common Memory Read 18

4.3.4 PC Card Memory Mode Common Memory Write 19

4.3.5 PC Card I/O Mode Read AC Characteristics 20

4.3.6 PC Card I/O Mode Write AC Characteristics 21

4.3.7 True IDE Mode Register Access..... 22

4.3.8 True IDE Mode PIO Access 23

4.3.9 True IDE Mode Multiword DMA 25

4.3.10 Ultra DMA AC Characteristics..... 26

5.0 Host Access Specification 35

5.1 Task File Register and Byte/Word/Odd-Byte Mode Mappings..... 35

5.2 Host Access Interface Modes..... 35

5.3 Card Information Structure (CIS)..... 36

5.4 Identify Drive Parameter..... 40

6.0 Registers 45

6.1 Configuration Registers 45

6.2 Task File Registers..... 46

7.0 Supported ATA Commands 47

8.0 SMART Feature Set..... 50

8.1 SMART Support and Identify Command 50

8.2 SMART Commands 50

8.3 SMART Attributes..... 51

9.0 Appendix: CompactFlash Adapter 52

9.1 CF Adapter Ordering Information 52

9.2 CF Adapter Specifications 52

9.3 CF Adapter Package Dimensions and Pin Locations..... 53

9.4 CF Adapter Pin Assignment 54

10.0 Revision History 55



1.0 Ordering Information

Table 1 lists the ordering part number for standard STEC MACH2 CompactFlash cards.

Note: Cards are shipped unformatted.

Table 1: Ordering Information

Part Number	CF Form Factor	Capacity
SLCF128M2PU(I)	Type I	128 MBytes
SLCF256M2PU(I)	Type I	256 MBytes
SLCF512M2PU(I)	Type I	512 MBytes
SLCF1GM2PU(I)	Type I	1 GBytes
SLCF2GM2PU(I)	Type I	2 GBytes
SLCF4GM2PU(I)	Type I	4 GBytes
SLCF8GM2PU(I)	Type I	8 GBytes
SLCF16GM2PU(I)	Type I	16 GBytes

Legend:

- **SLCF** = STEC standard CompactFlash card part number prefix.
- **G** = proceeding capacity (xxx) is in Gigabytes. Otherwise, capacity is in Megabytes.
- **M2P** = MACH2 controller.
- **U** = RoHS-6 compliant lead-free.
- **Part numbers without "I"** = Commercial temperature range (0°C to 70°C).
Example: SLCFxxx(G)M2PU
- **I** = Industrial temperature range (-40°C to +85 °C).
Example: SLCFxxx(G)M2PUI

2.0 Product Specifications

2.1 Labeling

STEC CF Cards can be manufactured with standard or custom (customer specified) front labeling.

The standard back label is available in "Standard" or "RoHS" pre-printed versions. Standard front and back labeling is shown in Figure 1.

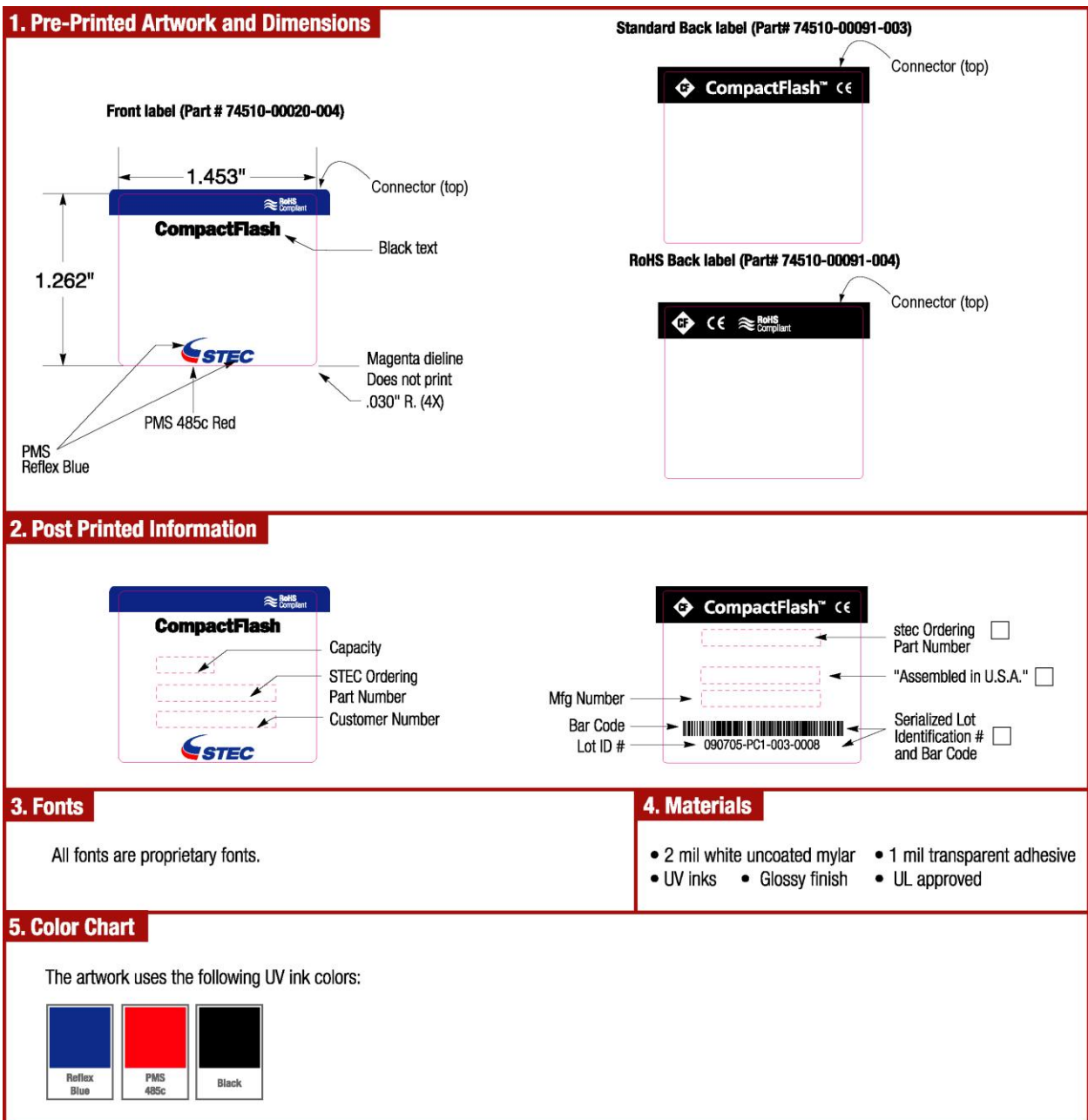

Figure 1: Standard Labeling

2.2 Package Dimensions and Pin Locations

Table 2 and Figure 2 show the mechanical dimensions of the CF Card Type I.

Table 2: Mechanical dimensions CF Card Type I

Parameter	Value
Length	36.40 ± 0.15 mm (1.433 ± 0.006 in)
Width	42.80 ± 0.10 mm (1.685 ± 0.004 in)
Height (including label area)	3.30 ± 0.10 mm (0.130 ± 0.004 in)

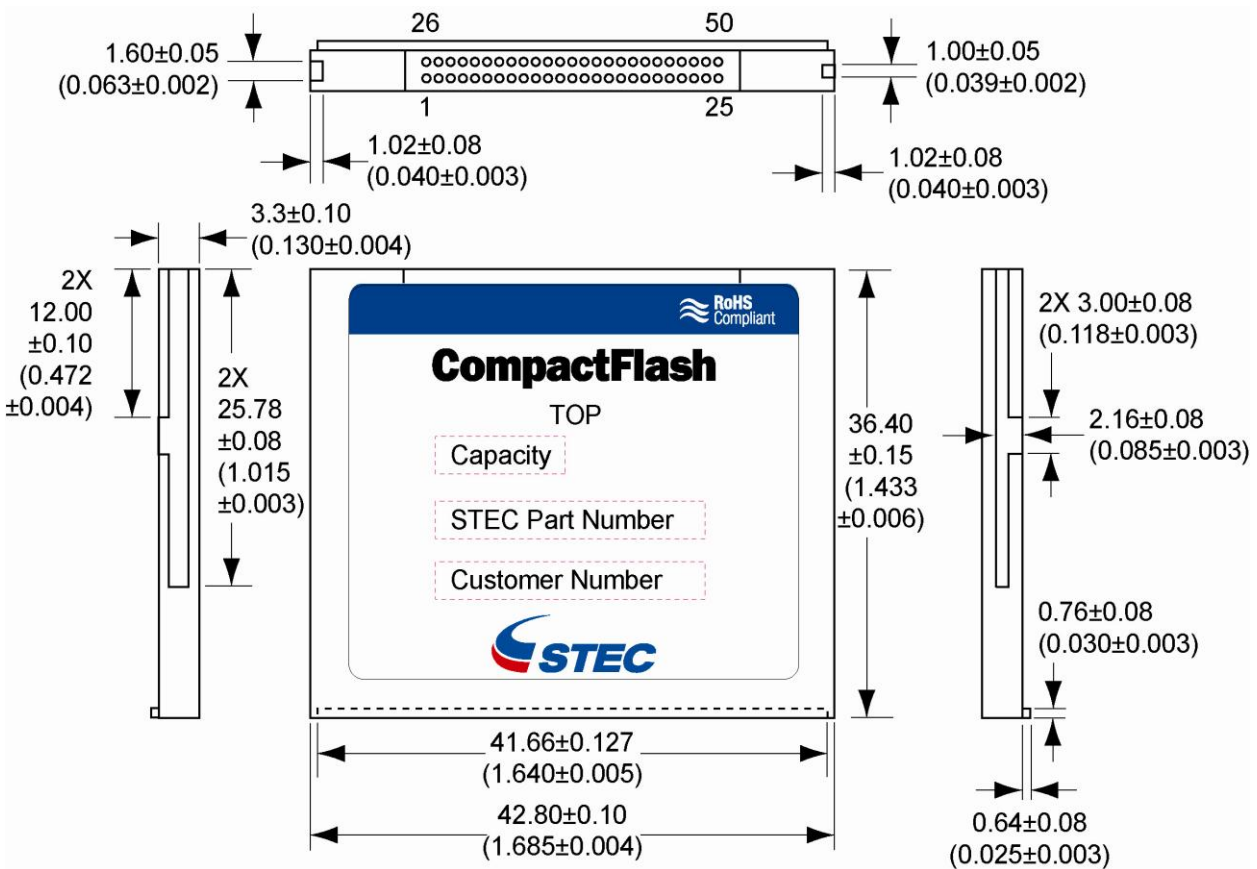

Figure 2: Mechanical dimensions CF Card Type I

2.3 Pin Assignments

Table 3: CF Card Pin Assignment

Pin Number	Signal Name	Pin Type	Pin Number	Signal Name	Pin Type
1	GND	Ground	26	-CD1	O
2	D03	I/O	27	D11	I/O
3	D04	I/O	28	D12	I/O
4	D05	I/O	29	D13	I/O
5	D06	I/O	30	D14	I/O
6	D07	I/O	31	D15	I/O
7	-CE1 -CS0	I	32	-CE2 -CS1	I
8	A10	I	33	-VS1	O
9	-OE -ATASEL	I	34	-IORD HSTROBE (-)HDMARDY	I
10	A09	I	35	-IOWR STOP	I
11	A08	I	36	-WE	I
12	A07	I	37	RDY/-BSY -IREQ INTRQ	O
13	VCC	Power	38	VCC	Power
14	A06	I	39	-CSEL	I
15	A05	I	40	-VS2	O
16	A04	I	41	(-)RESET	I
17	A03	I	42	-WAIT IORDY -DDMARDY DSTROBE	O
18	A02	I	43	-INPACK (-)DMARQ	O
19	A01	I	44	-REG (-)DMACK	I
20	A00	I	45	BVD2 -SPKR -DASP	I/O
21	D00	I/O	46	BVD1 -STSCHG -PDIAG	I/O
22	D01	I/O	47	D08	I/O
23	D02	I/O	48	D09	I/O
24	WP -IOIS16 -IOCS16	O	49	D10	I/O
25	-CD2	O	50	GND	Ground

Legend: "-" = Low active

2.4 Signal Description

Table 4: CF Card Signal Description

Signal Name	Type	Pin Number	Description
BVD2 (PC Card Memory Mode)	I/O	45	This output line is always driven to a high state in Memory Mode since a battery is not required for this product.
-SPKR (PC Card I/O Mode)			This output line is always driven to a high state in I/O Mode since this product produces no audio.
-DASP (True IDE Mode)			In the True IDE Mode, this input/output is the Disk Active/Slave Present signal in the Master/Slave handshake protocol.
-CD1, -CD2 (PC Card Memory Mode)	I/O	26, 25	These Card Detect pins are connected to ground on the card. They are used by the host to determine that the card is fully inserted into the socket.
-CD1, -CD2 (PC Card I/O Mode)			This signal is the same as Memory Mode.
-CD1, -CD2 (True IDE Mode)			These signals are not used in IDE Mode.
D15-D00 (PC Card Memory Mode)	I/O	31, 30, 29, 28, 27, 49, 48, 47, 6, 5, 4, 3, 2, 23, 22, 21	These lines carry the Data, Commands and Status information between the host and the controller. D00 is the LSB of the Even Byte of the Word. D08 is the LSB of the Odd Byte of the Word.
D15-D00 PC Card I/O Mode			This signal is the same as the PC Card Memory Mode signal.
D15-D00 (True IDE Mode)			In True IDE Mode, all Task File operations occur in byte mode on the low order bus D00-D07 while all data transfers are 16 bit using D00-D15.
-IOWR (PC Card Memory Mode except UDMA protocol active) STOP (All Modes: UDMA protocol active)	I	35	This signal is not used in this mode. In all modes, while UDMA mode protocol is active, the assertion of this signal causes the termination of the UDMA data burst.
-IOWR (PC Card I/O Mode except UDMA protocol active) STOP (All Modes: UDMA protocol active)			The I/O Write strobe pulse is used to clock I/O data onto the data bus and into the controller registers. The clocking occurs on the negative to positive edge of the signal (trailing edge). Same as STOP above.
-IOWR (True IDE Mode except UDMA protocol active) STOP (All Modes: UDMA protocol active)			In True IDE Mode, this signal has the same function as in PC Card I/O Mode. Same as STOP above.
-IORD (PC Card Memory Mode except UDMA protocol active)	I	34	This signal is not used in this mode.

-HDMARDY (All Modes: UDMA protocol DMA Read)			In all modes when UDMA mode DMA Read is active, this signal is asserted by the host to indicate that the host is ready to receive UDMA data-in bursts. The host may negate -HDMARDY to pause an UDMA transfer
HSTROBE (All Modes: UDMA protocol DMA Write)			In all modes when UDMA mode DMA Write is active, this signal is the data out strobe generated by the host. Both the rising and falling edge of HSTROBE cause data to be latched by the device. The host may stop generating HSTROBE edges to pause an UDMA data-out burst.
-IORD (PC Card I/O Mode except UDMA protocol active)			This is an I/O Read strobe generated by the host. This signal gates I/O data onto the bus from the CF Card.
-HDMARDY (All Modes: UDMA protocol DMA Read)			Same as -HDMARDY above.
HSTROBE (All Modes: UDMA protocol DMA Write)			Same as HSTROBE above.
-IORD (True IDE Mode except UDMA protocol active)			In True IDE Mode, this signal has the same function as in PC Card I/O Mode.
-HDMARDY (All Modes: UDMA protocol DMA Read)			Same as -HDMARDY above.
HSTROBE (All Modes: UDMA protocol DMA Write)			Same as HSTROBE above.
-WE (PC Card Memory Mode)	I	36	This is a signal driven by the host and used for strobing memory write data into the registers. It is also used for writing the configuration registers.
-WE (PC Card I/O Mode)			In PC Card I/O Mode, this signal is used for writing the configuration registers.
-WE (True IDE Mode)			In True IDE Mode, this input signal is not used and should be connected to VCC.
-OE (PC Card Memory Mode)	I	9	This is an Output Enable strobe generated by the host interface. It is used to read data from the CF Card in PC Card Memory Mode and to read the CIS and configuration registers.
-OE (PC Card I/O Mode)			In PC Card I/O Mode, this signal is used to read the CIS and configuration registers.
-ATASEL (True IDE Mode)			To enable True IDE Mode, this input should be grounded by the host.
RDY/-BSY (PC Card Memory Mode)	O	37	In Memory Mode, this signal is set high when the CF Card is ready to accept a new data transfer operation and held low when the CF Card is busy. The host must provide a pull-up resistor. At power up and at reset, the RDY/-BSY signal is held low (busy) until the CF Card completes its power up or reset function. No access of any type should be made to the CF Card during this time. The RDY/-BSY signal is held high (disabled from being busy) when the CF Card is powered up with RESET continuously disconnected or asserted high.
-IREQ (PC Card I/O Mode)			After card has been configured for I/O operation, signal is used as active low interrupt request. Strobe low to generate pulse mode interrupt or hold low for level mode interrupt.
INTRQ (True IDE Mode)			In True IDE Mode, this signal is the active high interrupt request to the host.

A10-A0 (PC Card Memory Mode)	I	8, 10, 11, 12, 14, 15, 16, 17, 18, 19, 20	These address lines along with the -REG signal are used to select the following: the I/O port address registers within the CF Card, the memory mapped port address registers within the CF Card, a byte in the CIS and the Configuration Control and Status Registers.
A10-A0 (PC Card I/O Mode)			This signal is the same as the PC Card Memory Mode signal.
A2-A0 (True IDE Mode)		18, 19, 20	In True IDE Mode only, A2:A0 are used to select the one of eight registers in the Task File. The remaining address lines should be grounded.
-CE1, -CE2 (PC Card Memory Mode) Card Enable	I	7, 32	These input signals are used both to select the CF Card and to indicate to the CF Card whether a byte or a word operation is being performed. -CE2 always accesses the odd byte of the word. -CE1 accesses the even byte or the odd byte of the word depending on A0 and -CE2. A multiplexing scheme based on A0, -CE1, -CE2 allows 8-bit hosts to access all data on D0-D7.
-CE1, -CE2 (PC Card I/O Mode) Card Enable			This signal is the same as the PC Card Memory Mode signal.
-CS0, -CS1 (True IDE Mode)			In the True IDE Mode, -CS0 is the chip enable for the task file registers while -CS1 is used to select the Alternate Status Register and the CF Card Control Register.
-CSEL (PC Card Memory Mode)	I	39	This signal is not used for this mode.
-CSEL (PC Card I/O Mode)			This signal is not used for this mode.
-CSEL (True IDE Mode)			This internally pulled up signal is used to configure the card as a Master or Slave. When the pin is grounded, the card is configured as a Master. When the pin is open, the card is configured as a Slave.
-REG (PC Card Memory Mode except UDMA protocol active) Attribute Memory Select -DMACK (PC Card Memory Mode when UDMA protocol is active)	I	44	<p>This signal distinguishes between accesses to Common Memory (high) and Register Attribute Memory (low). In PC Card Memory Mode, when UDMA protocol is supported by host and host has enable UDMA on the card, the host shall keep the -REG signal negated during the execution of any DMA Command by the device.</p> <p>This is a DMA Acknowledge signal that is asserted by the host in response to (-)DMARQ to initiate DMA transfers. In True IDE Mode, while DMA operations are not active, the card shall ignore the (-)DMARQ signal, including a floating condition. If DMA operation is not supported by a True IDE Mode only host, this signal should be driven high or connected to VCC by the host. A host that does not support DMA and implements both PC Card and True IDE modes of operation need not alter the PC Card mode connections while in True IDE mode as long as this does not prevent proper operation all modes</p>
-REG (PC Card I/O Mode except UDMA protocol active) DMACK (PC Card I/O Mode when UDMA protocol is active)			<p>The signal must also be active (low) during I/O Cycles when the I/O address is on the bus. In PC Card I/O Mode, when UDMA protocol is support by host and host has enable UDMA on card, the host shall keep the -REG signal asserted during the execution of any DMA Command by the device.</p> <p>Same as (-)DMACK above.</p>
-DMACK (True IDE Mode)			Same as (-)DMACK above.

WP (PC Card Memory Mode) Write Protect	O	24	The CF Card does not have a write protect switch; therefore, this signal is held low after the completion of the reset initialization sequence.
-IOIS16 (PC Card I/O Mode)			A low signal indicates that a 16 bit or odd byte only operation can be performed at the addressed port.
-IOCS16 (True IDE Mode)			In True IDE Mode this output signal is asserted low when this device is expecting a word data transfer cycle.
-INPACK (PC Card Memory Mode except UDMA protocol active) -DMARQ (PC Card Memory Mode: UDMA protocol active)	O	43	<p>This signal is not used in this mode.</p> <p>This signal is a DMA Request that is used for DMA data transfers between host and device. It shall be asserted by the device when it is ready to transfer data to or from the host. For Multiword DMA transfers, the direction of data transfer is controlled by -IORD and -LOWR. This signal is used in a handshake manner with (-)DMACK, i.e., the device shall wait until the host asserts (-)DMACK before negating (-)DMARQ, and re-asserting (-)DMARQ if there is more data to transfer.</p> <p>In PCMCIA I/O Mode, the -DMARQ shall be ignored by the host while the host is performing an I/O Read cycle to the device. The host shall not initiate an I/O Read cycle while -DMARQ is asserted by the device.</p> <p>In True IDE Mode, DMARQ shall not be driven when the device is not selected in the Drive-Head register.</p> <p>While a DMA operation is in progress, -CS0 (-CE1) and -CS1 (-CE2) shall be held negated and the width of the transfers shall be 16 bits.</p> <p>If there is no hardware support for True IDE DMA mode in the host, this output signal is not used and should not be connected at the host. In this case, the BIOS must report that DMA mode is not supported by the host so that device drivers will not attempt DMA mode operation.</p> <p>A host that does not support DMA mode and implements both PC Card and True IDE modes of operation need not alter the PC Card mode connections while in True IDE mode as long as this does not prevent proper operation in any mode.</p>
-INPACK (PC Card I/O Mode except UDMA protocol active) Input Acknowledge -DMARQ (PC Card I/O Mode: UDMA protocol active)			<p>The Input Acknowledge signal is asserted by the CF Card when it is selected and responding to an I/O read cycle at the address that is on the bus. The host uses this signal to control the enable of any input data buffers between the CF Card and the host's CPU.</p> <p>Same as (-)DMARQ above.</p>
DMARQ (True IDE Mode)			Same as (-)DMARQ above.
BVD1 (PC Card Memory Mode)	I/O	46	This signal is asserted high as since a battery is not used with this product.
-STSCHG (PC Card I/O Mode) Status Changed			Asserted low to alert host to changes in RDY/-BSY, Write Protect states. Use is controlled by Configuration and Status Register.
-PDIAG (True IDE Mode)			In True IDE Mode, this input/output signal is the Pass Diagnostic signal in the Master/Slave handshake protocol.

-WAIT (PC Card Memory Mode except UDMA protocol active) -DDMARDY (All Modes: UDMA Write protocol active) DSTROBE (All Modes: UDMA Read protocol active)	O	42	This signal is not used by the CF Card, and is pulled up to VCC through a 4.7K ohm resistor. In all modes, when Ultra DMA mode DMA Write is active, this signal is asserted by the device during a data burst to indicate that the device is ready to receive Ultra DMA data out bursts. The device may negate -DDMARDY to pause an Ultra DMA transfer. In all modes, when Ultra DMA mode DMA Read is active, this signal is the data in strobe generated by the device. Both the rising and falling edge of DSTROBE cause data to be latched by the host. The device may stop generating DSTROBE edges to pause an Ultra DMA data in burst
-WAIT (PC Card I/O Mode except UDMA protocol active) -DDMARDY (All Modes: UDMA Write protocol active) DSTROBE (All Modes: UDMA Read protocol active)			This signal is not used by the CF Card, and is pulled up to VCC through a 4.7K ohm resistor. Same as –DDMARDY above. Same as DSTROBE above.
IORDY (True IDE Mode except UDMA protocol active) -DDMARDY (All Modes: UDMA Write protocol active) DSTROBE (All Modes: UDMA Read protocol active)			This signal is not used by the CF Card, and is pulled up to VCC through a 4.7K ohm resistor. Same as –DDMARDY above. Same as DSTROBE above.
GND (PC Card Memory Mode)	GND	1, 50	Ground
GND (PC Card I/O Mode)			Ground
GND (True IDE Mode)			Ground
VCC (PC Card Memory Mode)	VCC	13, 38	+5 V or 3.3V power
VCC (PC Card I/O Mode)			+5 V or 3.3V power
VCC (True IDE Mode)			+5 V or 3.3V power
RESET (PC Card Memory Mode)	I	41	When RESET is high, this signal resets the CF Card. The CF Card is reset only at power up if this signal is left high or open from power-up. The CF Card can also be reset when the soft reset bit in the Configuration Option Register is set.
RESET (PC Card I/O Mode)			This signal is the same as the PC Card Memory Mode signal.
-RESET (True IDE Mode)			In the True IDE Mode this input pin is the active low hardware reset from the host.
-VS1 -VS2 (PC Card Memory Mode)	O	33, 40	-VS1 is grounded, so that the card CIS can be read 3.3 volts. -VS2 is reserved for a secondary voltage and is not connected.

-VS1 -VS2 (PC Card I/O Mode)			This signal is the same for all modes.
-VS1 -VS2 (True IDE Mode)			This signal is not used in IDE Mode.

2.5 Performance

Table 5: CF Card Read/Write Performance

Parameter	Flash Type	128MB-1GB	2GB-16GB
Data transfer rate to/from host	SLC	133 MBytes/s (burst)	133 MBytes/s (burst)
Sustained read	SLC	up to 20 MBytes/s	up to 40 MBytes/s
Sustained write	SLC	up to 12 MBytes/s	up to 29 MBytes/s

Note: Performance may vary under extreme temperatures.

2.6 LBA and CHS Parameters

Table 6: LBA and CHS Parameters per capacity

Capacity	Flash Type	Logical Block Addresses (LBA)	Cylinders (C) (standard)	Heads (H)	Sectors/Track (S)
128MB	SLC	250,880	980	8	32
256MB	SLC	501,760	980	16	32
512MB	SLC	1,000,944	993	16	63
1GB	SLC	2,001,888	1,986	16	63
2GB	SLC	3,844,512	3,814	16	63
4GB	SLC	7,709,184	7,648	16	63
8GB	SLC	15,435,504	15,313	16	63
16GB	SLC	30,926,448	30,681	16	63

Note: The unformatted capacity of the card may be less than the perceived or stated capacity on the label. Please use the LBA count in this table for reference.

2.7 Standards Compliance

STEC products specified in this document are certified for compliance with the following industry standards:

- CFA v4.1, PCMCIA v7.0
- UL 950
- CE, and FCC Class B & D
- RoHS

2.7.1 CE and FCC Class B & D

The STEC products specified in this document meet the following requirements and limits of the European Standards:

- **Class B** requirements of the following European Standard:
EN 55022: 1998 – “Information technology equipment – Radio disturbance characteristics – Limits and methods of measurement”
- **Class D** limits of the following European Standards:
EN 61000-3-2 “Electromagnetic compatibility (EMC) Part 3-2: Limits – Limits for harmonic current emissions (equipment input current up to and including 16 A per phase)”
EN 61000-3-3: 1995 – “Part 3: Limits – Section 3: Limitation of voltage fluctuations and flicker in low-voltage supply systems for equipment with rated current $\leq 16A$ ”
EN 55024 – “Information technology equipment – Immunity characteristics – Limits and methods of measurement”

2.7.2 RoHS

STEC certifies that its products do not contain any of the restricted substances as stated below and are in compliance with RoHS EU directive 2002/95/EC, specifically:

- Mercury (Hg)
- Cadmium Cd)
- Chromium VI (Cr +6)
- Polybrominated biphenyl (PBB)
- Polybrominated biphenyl ether (PBDE)
- Lead (Pb)

Materials used in the STEC’s products are limited to the following:

- Steel, Nylon 6/6, PCB laminate
- Copper, Gold, Nickel
- Silicon on ICs and Components
- Polyester on Labels

3.0 Environmental Specifications

3.1 Recommended Operating Conditions

Table 7: CF Card Recommended Operating Conditions

Parameter	Symbol	Min	Typ	Max	Unit
Commercial Operating Temperature	Ta1	0	25	70	°C
Industrial Operating Temperature	Ta2	-40	-	+85	°C
VCC voltage (5V)	VCC5.0	4.5	5.0	5.5	V
VCC voltage (3.3V)	VCC3.3	2.97	3.3	3.63	V

3.2 Reliability

Table 8: CF Card Reliability

Parameter	Value
MTBF	>4,000,000 power on hours, (per MIL-HDBK-217F, rated at 40°C, ground benign environment)
Endurance	2M program/erase cycles
Data reliability	Bit Error rate 10E-14 (NAND flash)
Data retention	10 years

3.3 Shock, Vibration, and Humidity

Table 9: CF Card Shock, Vibration & Humidity

Parameter	Value
Shock	1.5K G peak, 0.5ms pulse duration, five (5) pulses per each of six (6) directions (per JEDEC JESD22 standard, method B110)
Vibration	20 G peak, 20Hz-2000Hz, 4 cycles per direction (per JEDEC JESD22 standard, method B103)
Humidity	85°C 85% RH, 500 hrs

4.0 Electrical Specifications

4.1 Absolute Maximum Ratings

Table 10: CF Card Absolute Maximum Ratings

Parameter	Symbol	Value	Unit
Voltage	Vin, Vout	-0.5 to VCC +0.5	V
Storage temperature range	Tstg	-40 to +95	°C

4.2 DC Characteristics

Measurements at Recommended Operating Conditions unless otherwise specified.

Table 11: CF Card DC Characteristics

Symbol	Parameter	Min	Max	Unit	Notes
VIL (5V)	Input LOW Voltage	-0.3	+0.8	V	VCC= 5.0V
VIL (3.3V)	Input LOW Voltage	-0.3	+0.6	V	VCC= 3.3V
VIH (5V)	Input HIGH Voltage	4.0	VCC +0.3	V	VCC= 5.0V
VIH (3.3V)	Input HIGH Voltage	2.4	VCC +0.3	V	VCC= 3.3V
VOL	Output LOW Voltage		0.8		VCC=5.0V or 3.3V
VOH	Output HIGH Voltage	VCC-0.8		V	VCC=5.0V or 3.3V
ICCSB	Standby Mode	0.50	2	mA	ICC at VCC=5.0V or 3.3V
ICC	Operating Current	10	90	mA	ICC at VCC=5.0V or 3.3V
RPU	Pull-Up Resistance	100		K ohms	
RPD	Pull-Down Resistance	100		K ohms	

4.3 AC Characteristics

Measurements at Recommended Operating Conditions, unless otherwise specified.

4.3.1 PC Card Memory Mode Attribute Memory Read

Table 12: PC Card Memory Mode Attribute Memory Read AC Characteristics

Parameter	Symbol	IEEE Symbol	Min (ns)	Max (ns)
Read Cycle Time	tc(R)	tAVAV	300	
Address Access Time	ta(A)	tAVQV		300
Card Enable Access Time	ta(CE)	tELQV		300
Output Enable Access Time	ta(OE)	tGLQV		150
Output Disable Time from -CE	tdis(CE)	tEHQZ		100
Output Disable Time from -OE	tdis(OE)	tGHQZ		100
Address Setup Time	tsu(A)	tAVGL	30	
Output Enable Time from -CE	ten(CE)	tELQNZ	5	
Output Enable Time from -OE	ten(OE)	tGLQNZ	5	
Data Valid from Address Change	tv(A)	tAXQX	0	
Address Hold Time	th(A)	—	20	
-CE Setup Time	tsu(CE)	—	0	
-CE Hold Time	th(CE)	—	20	

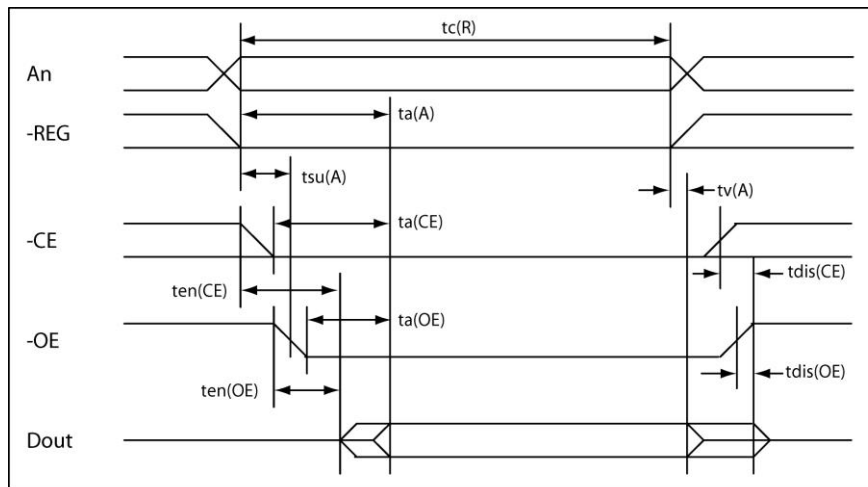

Figure 3: PC Card Memory Mode Attribute Memory Read Timing Diagram

4.3.2 PC Card Memory Mode Attribute Memory Write

Table 13: PC Card Memory Mode Attribute Memory Write AC Characteristics

Parameter	Symbol	IEEE Symbol	Min (ns)	Max (ns)
Write Cycle Time	$t_{c(W)}$	t_{AVAV}	250	
Write Pulse Width	$t_{w(WE)}$	t_{WLWH}	150	
Address Setup Time	$t_{su(A)}$	t_{AVWL}	30	
Address Setup Time (-WE)	$t_{su(A-WEH)}$	—	180	
-CE Setup Time (-WE)	$t_{su(CE-WEH)}$	—	180	
Data Setup Time (-WE)	$t_{su(D-WEH)}$	t_{DVWH}	80	
Data Hold Time	$t_{h(D)}$	t_{WMDX}	30	
Write Recovery Time	$t_{rec(WE)}$	t_{WMAX}	30	
Output Disable Time (-WE)	$t_{dis(WE)}$	—		100
Output Disable Time (-OE)	$t_{dis(OE)}$	—		100
Output Enable Time (-WE)	$t_{en(WE)}$	—		125
Output Enable Time (-OE)	$t_{en(OE)}$	—		125
Output Enable Setup Time (-WE)	$t_{su(OE-WE)}$	—	5	
Output Enable Hold Time (-WE)	$t_{h(OE-WE)}$	—	10	
-CE Setup Time	$t_{su(CE)}$	—	5	
-CE Hold Time	$t_{h(CE)}$	—	20	

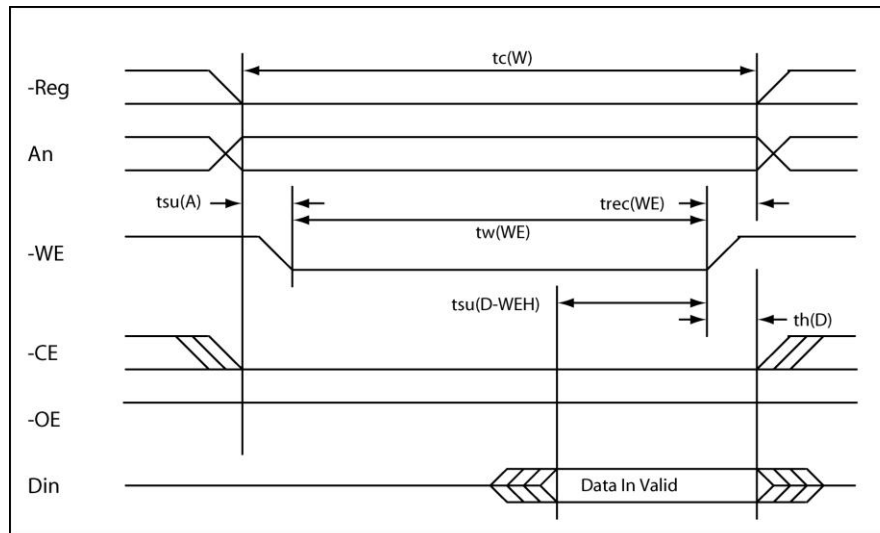

Figure 4: PC Card Memory Mode Attribute Memory Write Timing Diagram

4.3.3 PC Card Memory Mode Common Memory Read

Table 14: PC Card Memory Mode Common Memory Read AC Characteristics

Parameter	Symbol	IEEE Symbol	250 ns Cycle Time Mode	120 ns Cycle Time Mode	100 ns Cycle Time Mode	80 ns Cycle Time Mode
Output Enable Access Time (max)	ta(OE)	tGLQV	125	60	50	45
Output Disable Time from OE (max)	tdis(OE)	tGHQZ	100	60	50	45
Address Setup Time (min)	tsu(A)	tAVGL	30	15	10	10
Address Hold Time (min)	th(A)	tGHAX	20	15	15	10
CE Setup before OE (min)	tsu(CE)	tELGL	0	0	0	0
CE Hold following OE (min)	th(CE)	tGHEH	20	15	15	10
Wait Delay Falling from OE (max)	tv(WT-OE)	tGLWTV	35	35	35	N/A
Data Setup for Wait Release (max)	tv(WT)	tQVWTH	0	0	0	N/A
Wait Width Time (max)	tw(WT)	tWTLWTH	350	350	350	N/A

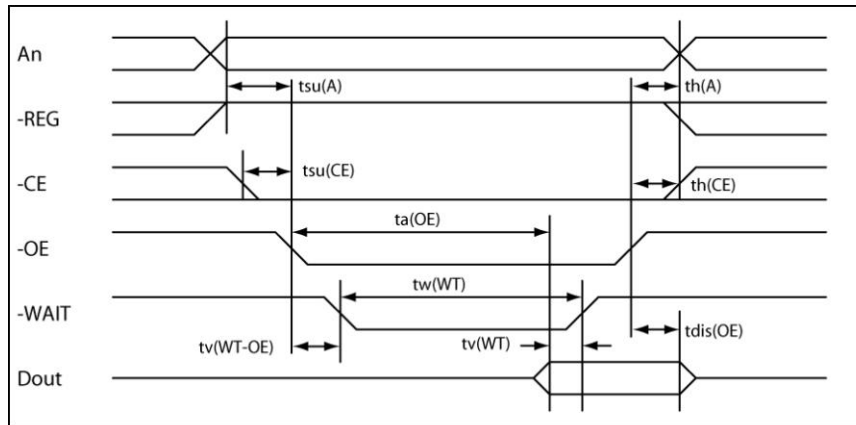

Figure 5: PC Card Memory Mode Common Memory Read Timing Diagram

4.3.4 PC Card Memory Mode Common Memory Write

Table 15: PC Card Memory Mode Common Memory Write AC Characteristics

Parameter	Symbol	IEEE Symbol	250 ns Cycle Time Mode	120 ns Cycle Time Mode	100 ns Cycle Time Mode	80 ns Cycle Time Mode
Data Setup before WE(min)	tsu(D-WEH)	tDVWH	80	50	40	30
Data Hold following WE (min)	th(D)	tWMDX	30	15	10	10
WE Pulse Width (min)	tw(WE)	tWLWH	150	70	60	55
Address Setup Time (min)	tsu(A)	tAVWL	30	15	10	10
CE Setup before WE (min)	tsu(CE)	tELWL	0	0	0	0
Write Recovery Time (min)	trec(WE)	tWMAX	30	15	15	15
Address Hold Time (min)	th(A)	tGHAX	20	15	15	15
CE Hold following WE (min)	th(CE)	tGHEH	20	15	15	10
Wait Delay Falling from WE (max)	tv(WT-WE)	tWLWTV	35	35	35	N/A
WE High from Wait Release (min)	tv(WT)	tWTHWH	0	0	0	N/A
Wait Width Time (max)	tw(WT)	tWTLWTH	350	350	350	N/A

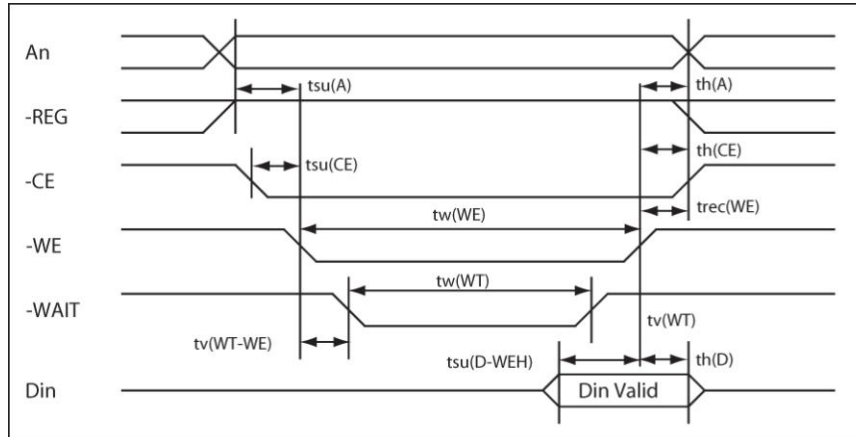

Figure 6: PC Card Memory Mode Common Memory Write Timing Diagram

4.3.5 PC Card I/O Mode Read AC Characteristics

Table 16: PC Card I/O Mode Read AC Characteristics

Parameter	Symbol	IEEE Symbol	250 ns Cycle Time Mode	120 ns Cycle Time Mode	100 ns Cycle Time Mode	80 ns Cycle Time Mode
Data Delay after -IORD (max)	td(IORD)	tIGLQV	100	50	50	45
Data Hold following -IORD (min)	th(IORD)	tIGHQX	0	5	5	5
-IORD Width Time (min)	tw(IORD)	tIGLIGH	165	70	65	55
Address Setup before -IORD (min)	tsuA(IORD)	tAVIGL	70	25	25	15
Address Hold following -IORD (min)	thA(IORD)	tIGHAX	20	10	10	10
-CE Setup before -IORD (min)	tsuCE(IORD)	tELIGL	5	5	5	5
-CE Hold following -IORD (min)	thCE(IORD)	tIGHEH	20	10	10	10
-REG Setup before -IORD (min)	tsuREG(IORD)	tRGLIGL	5	5	5	5
-REG Hold following -IORD (min)	thREG(IORD)	tIGHRGH	0	0	0	0

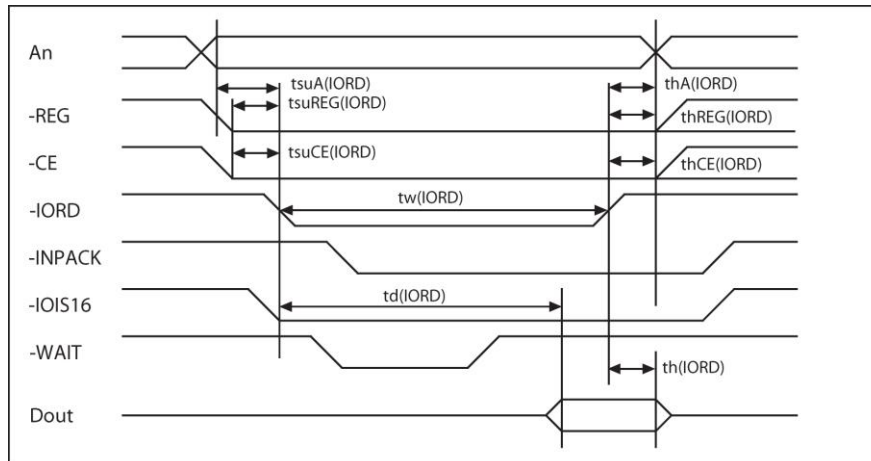

Figure 7: PC Card I/O Mode Read Timing Diagram

4.3.6 PC Card I/O Mode Write AC Characteristics

Table 17: PC Card I/O Mode Write AC Characteristics

Parameter	Symbol	IEEE Symbol	250 ns Cycle Time Mode	120 ns Cycle Time Mode	100 ns Cycle Time Mode	80 ns Cycle Time Mode
Data Setup before -IOWR (min)	tsu(IOWR)	tDVIWH	60	20	20	15
Data Hold following -IOWR (min)	th(IOWR)	tIWHDX	30	10	5	5
-IOWR Width Time (min)	tw(IOWR)	tIWLIIWH	165	70	65	55
Address Setup before -IOWR (min)	tsuA(IOWR)	tAVIWL	70	25	25	15
Address Hold following -IOWR (min)	thA(IOWR)	tIWHAX	20	20	10	10
-CE Setup before -IOWR (min)	tsuCE(IOWR)	tELIWL	5	5	5	5
-CE Hold following -IOWR (min)	thCE(IOWR)	tIWHEH	20	20	10	10
-REG Setup before -IOWR (min)	tsuREG(IOWR)	tRGLIWL	5	5	5	5
-REG Hold following -IOWR (min)	thREG(IOWR)	tIWHRGH	0	0	0	0

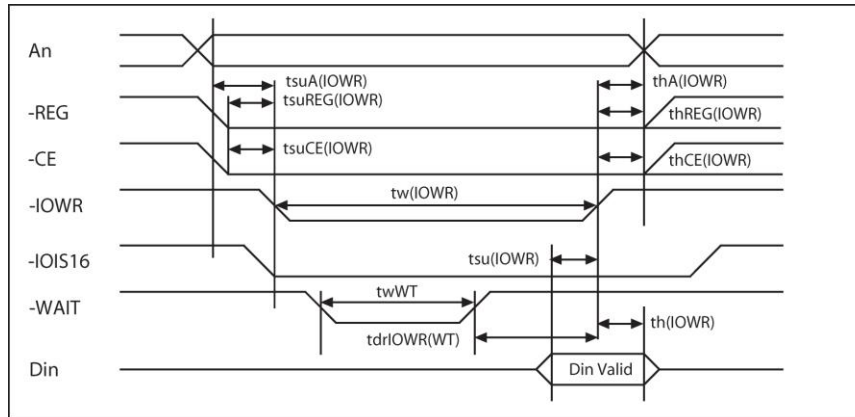

Figure 8: PC Card I/O Mode Read Timing Diagram

4.3.7 True IDE Mode Register Access

Table 18: True IDE Mode Register Access AC Characteristics

Parameter	Symbol	Mode0	Mode1	Mode2	Mode3	Mode4	Mode5	Mode6	Unit
Cycle time (min)	t0	600	383	330	180	120	100	80	ns
Address valid to -IORD/-IOWR (min) setup	t1	70	50	30	30	25	15	10	ns
-IORD/-IOWR pulse width 8bit (min)	t2	290	290	290	80	70	65	55	ns
-IORD/-IOWR recovery time (min)	t2i	—	—	—	70	25	25	20	ns
-IOWR data setup (min)	t3	60	45	30	30	20	20	15	ns
-IOWR data hold (min)	t4	30	20	15	10	10	5	5	ns
-IORD data setup (min)	t5	50	35	20	20	20	15	10	ns
-IORD data hold (min)	t6	5	5	5	5	5	5	5	ns
-IORD data tristate (max)	t6z	30	30	30	30	30	20	20	ns
Addresses valid to -IOCS16 assert. (max)	t7	90	50	40	N/A	N/A	N/A	N/A	ns
Address valid to -IOCS16 release (max)	t8	60	45	30	N/A	N/A	N/A	N/A	ns
-IORD/-IOWR to address valid hold	t9	20	15	10	10	10	10	10	ns

4.3.8 True IDE Mode PIO Access

Table 19: True IDE Mode PIO Access AC Characteristics

Parameter	Symbol	Mode0	Mode1	Mode2	Mode3	Mode4	Mode5	Mode6	Unit
Cycle time (min)	t0	600	383	330	180	120	100	80	ns
Address valid to -IORD/-IOWR (min) setup	t1	70	50	30	30	25	15	10	ns
-IORD/-IOWR pulse width 8bit (min)	t2	290	290	290	80	70	65	55	ns
-IORD/-IOWR recovery time (min)	t2i	—	—	—	70	25	25	20	ns
-IOWR data setup (min)	t3	60	45	30	30	20	20	15	ns
-IOWR data hold (min)	t4	30	20	15	10	10	5	5	ns
-IORD data setup (min)	t5	50	35	20	20	20	15	10	ns
-IORD data hold (min)	t6	5	5	5	5	5	5	5	ns
-IORD data tristate (max)	t6z	30	30	30	30	30	20	20	ns
Addresses valid to -IOCS16 assert. (max)	t7	90	50	40	N/A	N/A	N/A	N/A	ns
Address valid to -IOCS16 release	t8	60	45	30	N/A	N/A	N/A	N/A	ns
-IORD/-IOWR to address valid hold	t9	20	15	10	10	10	10	10	ns

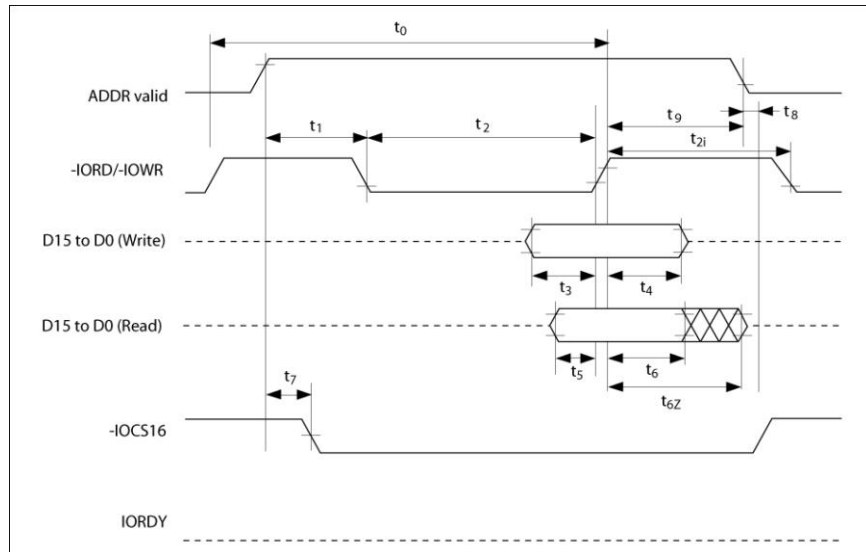

Figure 9: True IDE Mode PIO Access Timing Diagram

4.3.9 True IDE Mode Multiword DMA

Table 20: True IDE Mode Multiword DMA AC Characteristics

Parameter	Symbol	Mode 0	Mode 1	Mode 2	Mode 3	Mode 4	Unit
Cycle time (min)	t_0	480	150	120	100	80	ns
-IORD/-IOWR Asserted Pulse (min)	t_D	215	80	70	65	55	ns
-IORD data access (max)	t_E	150	60	50	50	45	ns
-IORD data hold (min)	t_F	5	5	5	5	5	ns
-IORD/-IOWR data setup (min)	t_G	100	30	20	15	10	ns
-IOWR data hold (min)	t_H	20	15	10	5	5	ns
DMACK to -IORD/-IOWR setup (min)	t_I	0	0	0	0	0	ns
-IORD/-IOWR to DMACK hold (min)	t_J	20	5	5	5	5	ns
-IORD negated pulse width (max)	t_{KR}	50	50	25	25	20	ns
-IOWR negated pulse width (min)	t_{KW}	215	50	25	25	20	ns
-IORD to DMARQ delay (max)	t_{LR}	120	40	35	35	35	ns
-IOWR to DMARQ delay (max)	t_{LW}	40	40	35	35	35	ns

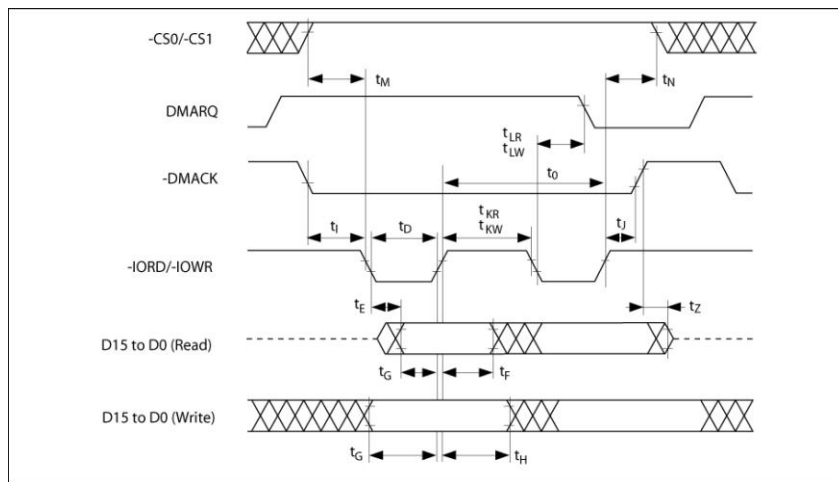

Figure 10: True IDE Mode Multiword DMA Timing Diagram

4.3.10 Ultra DMA AC Characteristics

Table 21: UDMA Burst Timing Requirements

Symbol	UDMA0 (ns)	UDMA1 (ns)	UDMA2 (ns)	UDMA3 (ns)	UDMA4 (ns)	Measure location (see Note2)
t2CYCTYP (min)	240	160	120	90	60	Sender
tCYC (min)	112	73	54	39	25	Note3
t2CYC (min)	230	153	115	86	57	Sender
tDS (min)	15.0	10.0	7.0	7.0	5.0	Recip'nt
tDH (min)	5.0	5.0	5.0	5.0	5.0	Recip'nt
tDVS (min)	70.0	48.0	31.0	20.0	6.7	Sender
tDVH (min)	6.2	6.2	6.2	6.2	6.2	Sender
tCS (min)	15.0	10.0	7.0	7.0	5.0	Device
tCH (min)	5.0	5.0	5.0	5.0	5.0	Device
tCVS (min)	70.0	48.0	31.0	20.0	6.7	Host
tCVH (min)	6.2	6.2	6.2	6.2	6.2	Host
tZFS (min)	0	0	0	0	0	Device
tDZFS (min)	70.0	48.0	31.0	20.0	6.7	Sender
tFS (max)	230	200	170	130	120	Device
tLI (min)	0	0	0	0	0	Note4
tLI (max)	150	150	150	100	100	Note4
tMLI (min)	20	20	20	20	20	Host
tUI (min)	0	0	0	0	0	Host
tAZ (max)	10	10	10	10	10	Note5
tZAH (min)	20	20	20	20	20	Host
tZAD (min)	0	0	0	0	0	Device
tENV (min)	20	20	20	20	20	Host
tENV (max)	70	70	70	55	55	Host
tRFS (max)	75	70	60	60	60	Sender
tRP (min)	160	125	100	100	100	Recip'nt
tIORDYZ (max)	20	20	20	20	20	Device
tZIORDY (min)	0	0	0	0	0	Device
tACK (min)	20	20	20	20	20	Host
tSS (min)	50	50	50	50	50	Sender

Notes:

1. All timing measurement switching points (low to high and high to low) shall be taken at 1.5 V.
2. All signal transitions for a timing parameter shall be measured at the connector specified in the measurement location column. For example, in the case of tRFS, both STROBE and -DMARDY transitions are measured at the sender connector.
3. The parameter tCYC shall be measured at the recipient's connector farthest from the sender.
4. The parameter tLI shall be measured at the connector of the sender or recipient that is responding to an incoming transition from the recipient or sender respectively. Both the incoming signal and the outgoing response shall be measured at the same connector.
5. The parameter tAZ shall be measured at the connector of the sender or recipient that is driving the bus but must release the bus to allow for a bus turnaround.

Table 22: UDMA Timing Parameter Descriptions

Symbol	Parameter
t2CYCTYP	Typical sustained average two cycle time
tCYC	Cycle time allowing for asymmetry and clock variations (from STROBE edge to STROBE edge)
t2CYC	Two cycle time allowing for clock variations (from rising edge to next rising edge or from falling edge to next falling edge of STROBE)
tDS	Data setup time at recipient (from data valid until STROBE edge)
tDH	Data hold time at recipient (from STROBE edge until data may become invalid)
tDVS	Data valid setup time at sender (from data valid until STROBE edge)
tDVH	Data valid hold time at sender (from STROBE edge until data may become invalid)
tCS	CRC word setup time at device
tCH	CRC word hold time device
tCVS	CRC word valid setup time at host (from CRC valid until -DMACK negation)
tCVH	CRC word valid hold time at sender (from -DMACK negation until CRC may become invalid)
tZFS	Time from STROBE output released-to-driving until the first transition of critical timing.
tDZFS	Time from data output released-to-driving until the first transition of critical timing.
tFS	First STROBE time (for device to first negate DSTROBE from STOP during a data in burst)
tLI	Limited interlock time
tMLI	Interlock time with minimum
tUI	Unlimited interlock time
tAZ	Maximum time allowed for output drivers to release (from asserted or negated)
tZAH	Minimum delay time required for output
tZAD	Drivers to assert or negate (from released)
tENV	Envelope time (from -DMACK to STOP and -HDMARDY during data in burst initiation and from DMACK to STOP during data out burst initiation)
tRFS	Ready-to-final-STROBE time (no STROBE edges shall be sent this long after negation of -DMARDY)
tRP	Ready-to-pause time (that recipient shall wait to pause after negating -DMARDY)
tIORDYZ	Maximum time before releasing IORDY
tZIORDY	Minimum time before driving IORDY
tACK	Setup and hold times for -DMACK (before assertion or negation)
tSS	Time from STROBE edge to negation of DMARQ or assertion of STOP (when sender terminates a burst)

Table 23: Ultra DMA Sender and Recipient IC Timing Requirements

Symbol	UDMA0	UDMA1	UDMA2	UDMA3	UDMA4	Unit
tDSIC (min)	14.7	9.7	6.8	6.8	4.8	ns
tDHIC (min)	4.8	4.8	4.8	4.8	4.8	ns
tDVSIC (min)	72.9	50.9	33.9	22.6	9.5	ns
tDVHIC (min)	9.0	9.0	9.0	9.0	9.0	ns

Table 24: Ultra DMA Sender and Recipient IC Timing Parameter Descriptions

Symbol	Parameter
tDSIC	Recipient IC data setup time (from data valid until STROBE edge)
tDHIC	Recipient IC data hold time (from STROBE edge until data may become invalid)
tDVSIC	Sender IC data valid setup time (from data valid until STROBE edge)
tDVHIC	Sender IC data valid hold time (from STROBE edge until data may become invalid)

Table 25: Ultra DMA AC Signal Requirements

Symbol	Parameter	Max (V/ns)
SRISE	Rising Edge Slew Rate for any signal	1.25
SFALL	Falling Edge Slew Rate for any signal	1.25

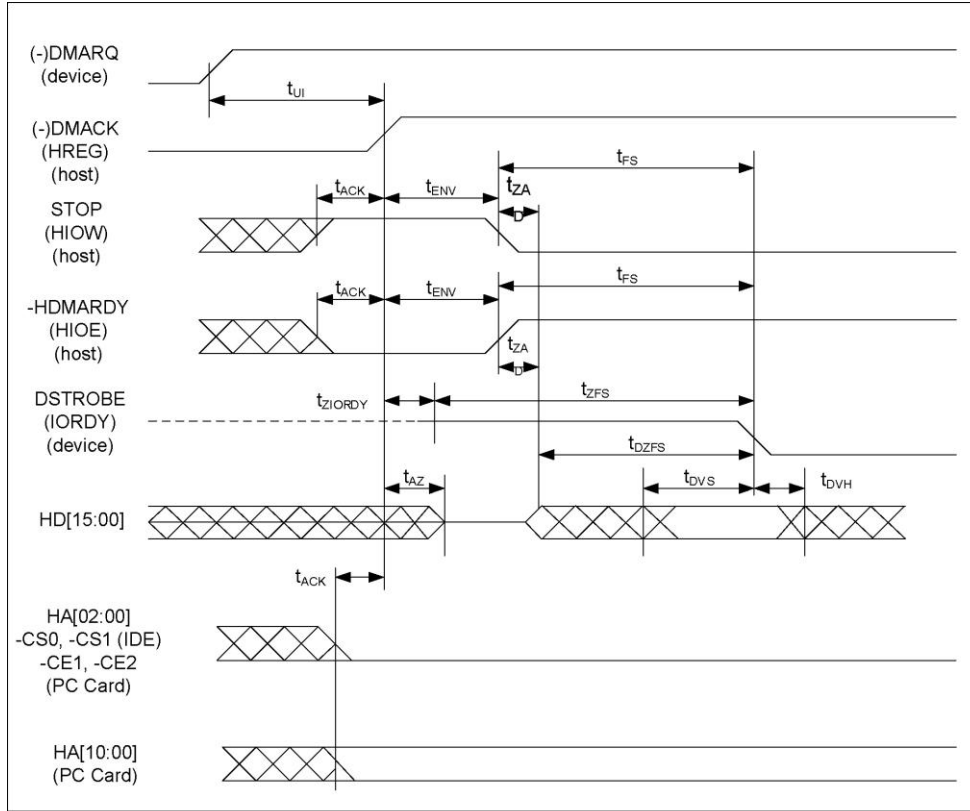

Note: All waveforms in this diagram are shown with the asserted state high.
Negative true signals appear inverted on the bus relative to the diagram.

Figure 11: UDMA Data-In Burst Initiation Timing

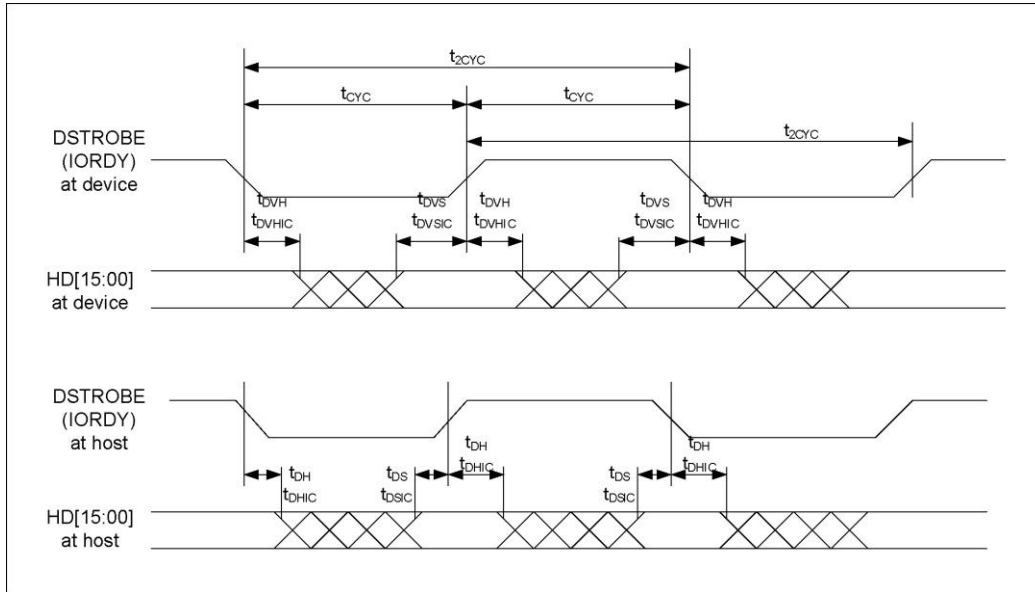
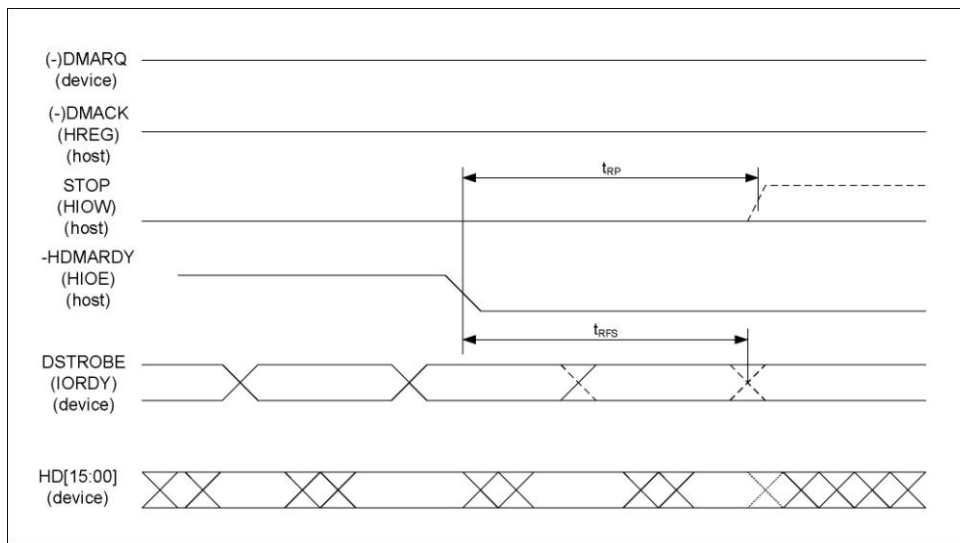
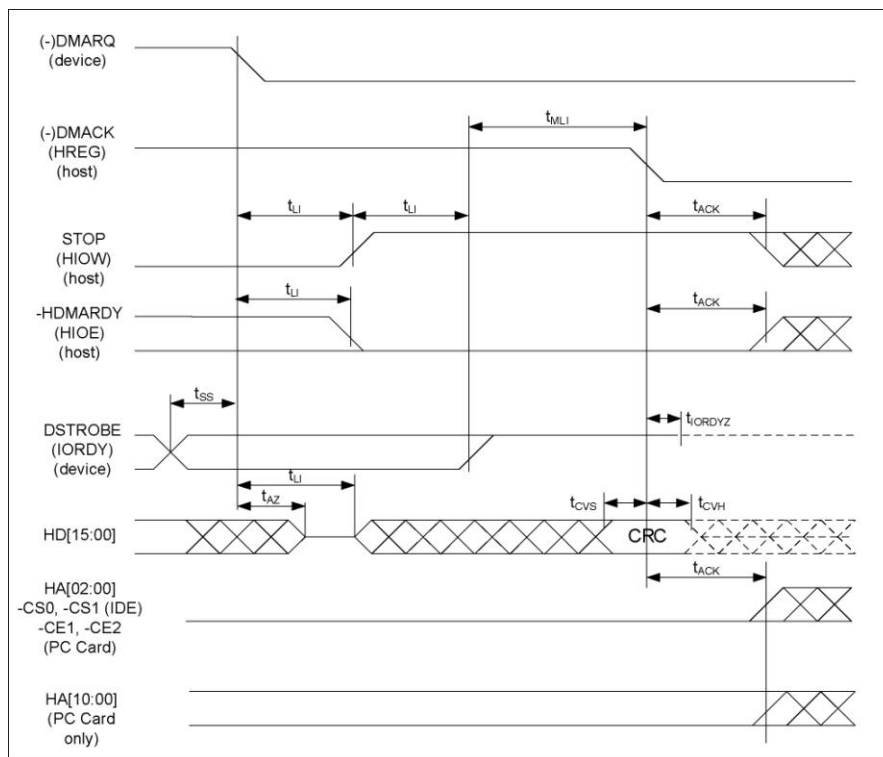

Figure 12: Sustained UDMA Data-In Burst Timing



Note: All waveforms in this diagram are shown with the asserted state high.
 Negative true signals appear inverted on the bus relative to the diagram.

Figure 13: UDMA Data-In Burst Host Pause Timing



Note: All waveforms in this diagram are shown with the asserted state high.
 Negative true signals appear inverted on the bus relative to the diagram.

Figure 14: UDMA Data-In Burst Device Termination Timing

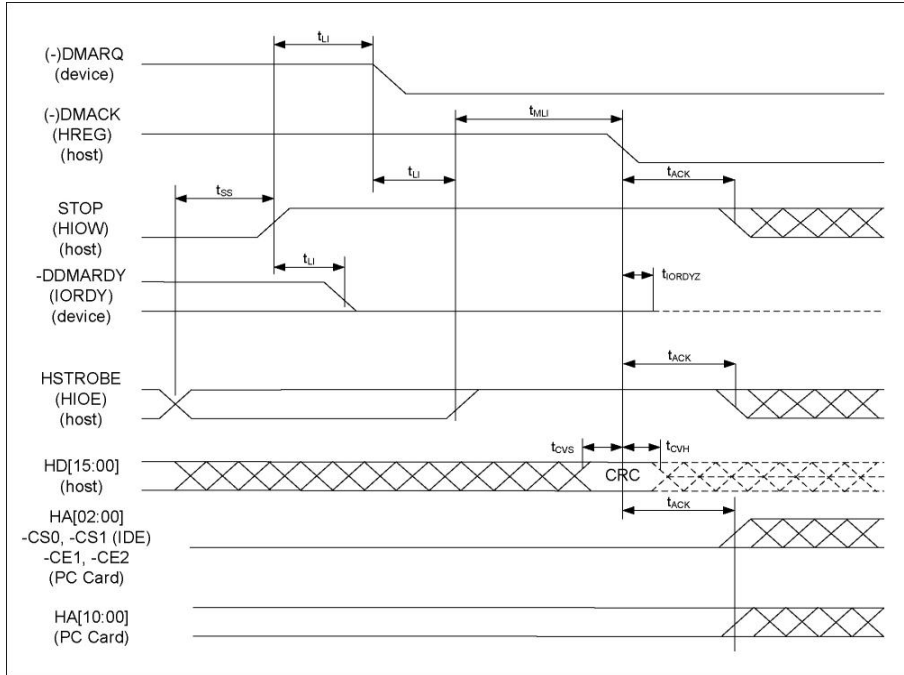

Note: All waveforms in this diagram are shown with the asserted state high. Negative true signals appear inverted on the bus relative to the diagram.

Figure 15: UDMA Data-In Burst Host Termination Timing

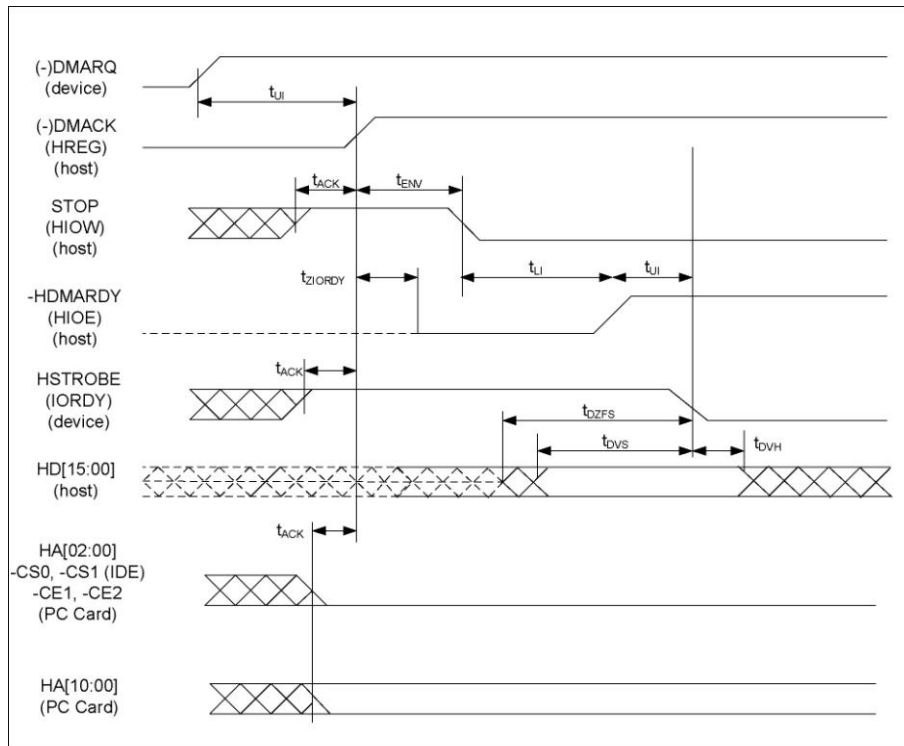

Note: All waveforms in this diagram are shown with the asserted state high. Negative true signals appear inverted on the bus relative to the diagram.

Figure 16: UDMA Data-Out Burst Initiation Timing

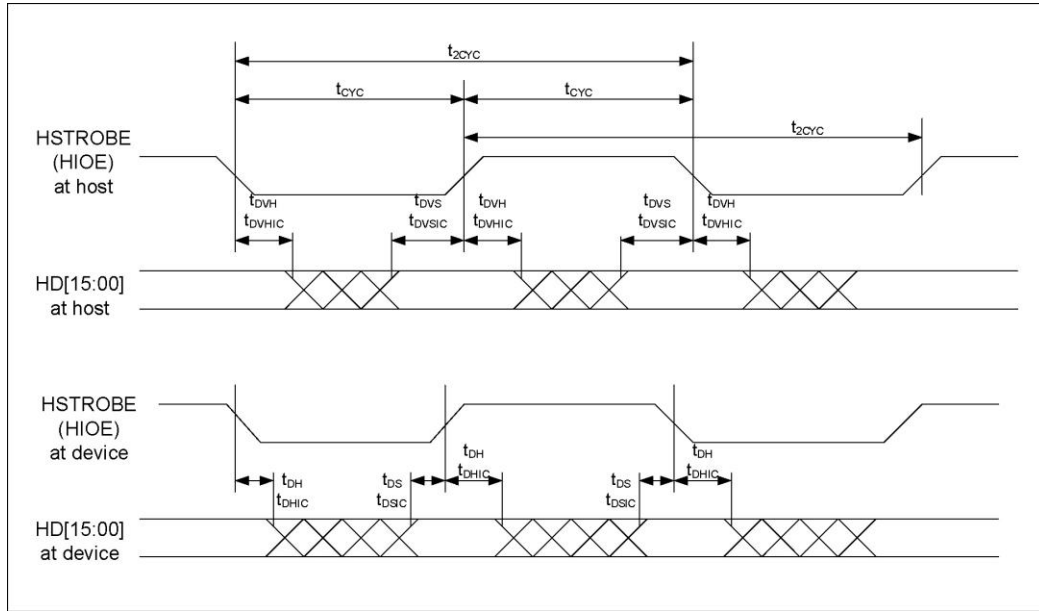
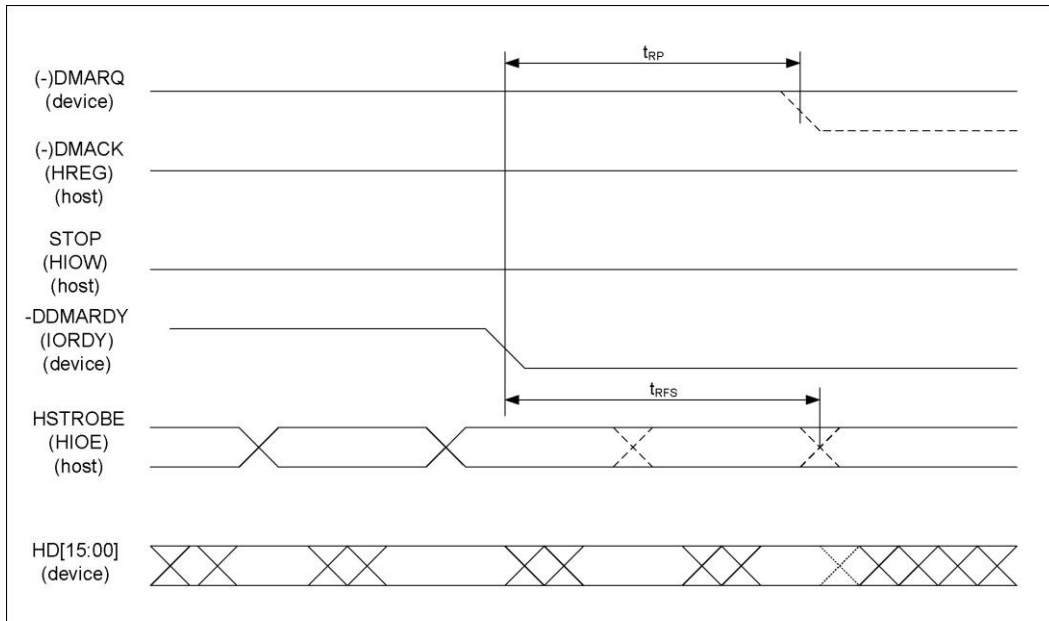
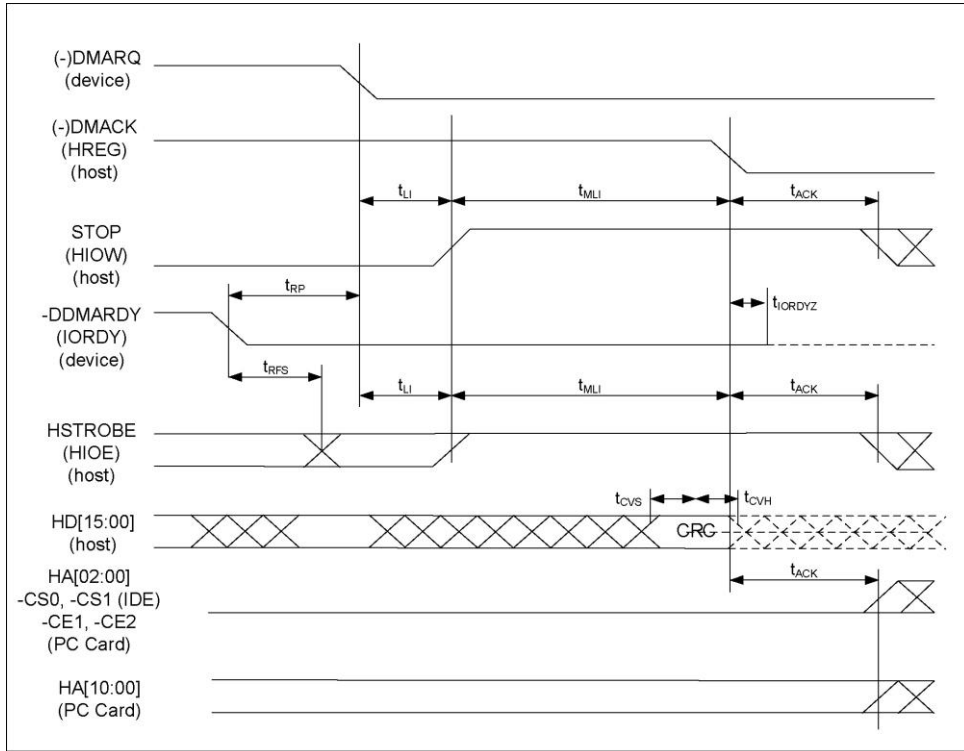

Figure 17: Sustained UDMA Data-Out Burst Timing



Note: All waveforms in this diagram are shown with the asserted state high.
Negative true signals appear inverted on the bus relative to the diagram.

Figure 18: UDMA Data-Out Burst Device Pause Timing



Note: All waveforms in this diagram are shown with the asserted state high. Negative true signals appear inverted on the bus relative to the diagram.

Figure 19: UDMA Data-Out Burst Device Termination Timing

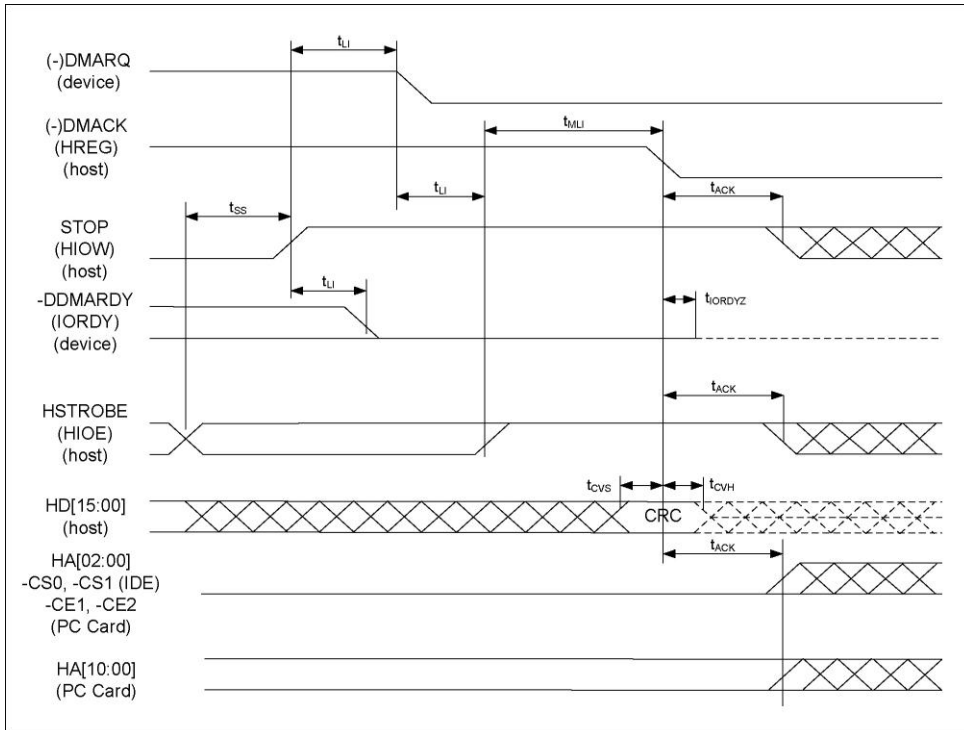

Note: All waveforms in this diagram are shown with the asserted state high. Negative true signals appear inverted on the bus relative to the diagram.

Figure 20: UDMA Data-Out Burst Host Termination Timing

5.0 Host Access Specification

5.1 Task File Register and Byte/Word/Odd-Byte Mode Mappings

Please refer to the CompactFlash standard for complete details on the following items:

Task File Register mapping for the interface modes

Byte/Word/Odd-byte mode mapping within each of the interface modes

5.2 Host Access Interface Modes

The host can access the CF Card by using the following interface modes with the Task Registers:

PC Card Memory Mode, Attribute Memory

The Card Information Structure (CIS) in Attribute Memory can be accessed by Byte/Word/Odd-byte modes in PC Card Memory Mode. The -REG signal must be asserted when accessing Attribute Memory. The CF Card is mapped to PC Card Memory Mode by the Index bits in the Configuration Option Register. An example of a CIS is listed in 4.3, *Card Information Structure (CIS)*.

PC Card Memory Mode, Common Memory

Common Memory can be accessed in the Byte/Word/Odd Byte modes in PC Card Memory Mode. The -REG signal must be de-asserted when accessing the Common Memory. The CF Card is mapped to PC Card Memory Mode by the Index bits in the Configuration Option Register

PC Card I/O Mode

The CF Card can be accessed by Byte/Word/Odd Byte modes in PC Card I/O Mode. The CF Card is mapped to PC Card I/O Mode by the Index bits in the Configuration Option Register. The Index bits also select Contiguous I/O, Primary I/O, or Secondary I/O mapping when using the PC Card I/O Mode.

True-IDE mode

The CF Card is configured in a True IDE Mode of operation when the -ATASEL input signal is asserted GND by the host at power up. In the True IDE Mode, Attribute Registers are not accessible from the host. The Data Register is accessed in word (16-bit) mode at power up. The CF Card permits 8-bit accesses if the host issues a Set Feature Command to put the CF Card in 8-bit mode. Parameter information that the CF Card uses in True IDE mode is returned when the Identify Drive command (ECh) is invoked. Refer to 5.4 *Identify Drive Parameter* for an example.

5.3 Card Information Structure (CIS)

The card uses a Card Information Structure (CIS) as summarized below:

1. 0000: Code 01, link 04
D79 01 FF
Tuple CISTPL_DEVICE (01), length 4 (04) at offset 0
 - Device type is FUNCSPEC
 - Device speed is 80ns
 - Write protect switch is not in control
 - Device size is 2K bytes
2. 0006: Code 1C, link 05
02 DF 79 01 FF
Tuple CISTPL_DEVICE_OC (1C), length 5 (05) at offset 6
 - Device conditions: minimum cycle with WAIT at Vcc = 3.3V
 - Device type is FUNCSPEC
 - Device speed is 80ns
 - Write protect switch is not in control
 - Device size is 2K bytes
3. 000D: Code 18, link 02
DF 01
Tuple CISTPL_JEDEC_C (18), length 2 (02) at offset B
 - Device 0 JEDEC id: Manufacturer DF, ID 01
4. 0011: Code 20, link 04
4F 00 00 00
Tuple CISTPL_MANFID (20), length 4 (04) at offset 11
 - Manufacturer # 0x004F hardware rev 0.00
5. 0017: Code 15, link 14
04 01 53 54 45 43 20 4D 32 00 53 54 45 43 20 4D 32 00 00 FF
Tuple CISTPL_VERS_1 (15), length 20 (14) at offset 17
 - Major version 4, minor version 1
 - Product Information: "STEC M2" (Manufacturer) "STEC M2" (Product Name)
6. 002D: Code 21, link 02
04 /xx 01
Tuple CISTPL_FUNCID (21), length 2 (02) at offset 2D
Function code 04 (Fixed), or xx (Removable), system init 01
7. 0031: Code 22, link 02
01 01
Tuple CISTPL_FUNCE (22), length 2 (02) at offset 31
 - This is an PC Card ATA Disk

8. 0035: Code 22, link 03
02 0C 0F
Tuple CISTPL_FUNCE (22), length 3 (03) at offset 35
 - Vpp is not required
 - This is a silicon device
 - Identify Drive Model/Serial Number is guaranteed unique
 - Low-Power Modes supported: Sleep Standby Idle
 - Drive automatically minimizes power
 - All modes include 3F7 or 377
 - Index bit is not supported
 - -IOIS16 is unspecified in Twin configurations
9. 003A: Code 1A, link 05
01 03 00 02 0F
Tuple CISTPL_CONFIG (1A), length 5 (05) at offset 3A
 - Last valid configuration index is 3
 - Configuration Register Base Address is 200
 - Configuration Registers Present:
 - Configuration Option Register at 200
 - Card Configuration and Status Register at 202
 - Pin Replacement Register at 204
 - Socket and Copy Register at 206
10. 0041: Code 1B, link 08
C0 C0 A1 01 55 08 00 20
Tuple CISTPL_CFTABLE_ENTRY (1B), length 8 (08) at offset 41
 - Configuration Table Index is 00 (default)
 - Interface type is Memory
 - BVDs not active, WP not active, RdyBsy active
 - Wait signal support required
 - Vcc Power Description: Nom V = 5.0 V
 - Map 2048 bytes of memory to CF Card address 0
 - Miscellaneous Features: Max Twins 0, -Audio, -ReadOnly, +PowerDown
11. 004B: Code 1B, link 06
00 01 21 B5 1E 4D
Tuple CISTPL_CFTABLE_ENTRY (1B), length 6 (06) at offset 4B
 - Configuration Table Index is 00
 - Vcc Power Description: Nom V = 3.30 V, Peak I = 45.0 mA

12. 0053: Code 1B, link 0A
C1 41 99 01 55 64 F0 FF FF 20
Tuple CISTPL_CFTABLE_ENTRY (1B), length 10 (0A) at offset 53
 - Configuration Table Index is 01 (default)
 - Interface type is I/O
 - BVDs not active, WP not active, RdyBsy active
 - Wait signal support not required
 - Vcc Power Description: Nom V = 5.0 V
 - Decode 4 I/O lines, bus size 8 or 16
 - IRQ may be shared, pulse and level mode interrupts are supported
 - Interrupts in mask FFFF are supported
 - Miscellaneous Features: Max Twins 0, -Audio, -ReadOnly, +PowerDown
13. 005F: Code 1B, link 06
01 01 21 B5 1E 4D
Tuple CISTPL_CFTABLE_ENTRY (1B), length 6 (06) at offset 5F
 - Configuration Table Index is 01
 - Vcc Power Description: Nom V = 3.30 V, Peak I = 45.0 mA
14. 0067: Code 1B, link 0F
C2 41 99 01 55 EA 61 F0 01 07 F6 03 01 EE 20
Tuple CISTPL_CFTABLE_ENTRY (1B), length 15 (0F) at offset 67
 - Configuration Table Index is 02 (default)
 - Interface type is I/O
 - BVDs not active, WP not active, RdyBsy active
 - Wait signal support not required
 - Vcc Power Description: Nom V = 5.0 V
 - Decode 10 I/O lines, bus size 8 or 16
 - I/O block at 01F0, length 8
 - I/O block at 03F6, length 2
 - IRQ may be shared, pulse and level mode interrupts are supported
 - Only IRQ14 is supported
 - Miscellaneous Features: Max Twins 0, -Audio, -ReadOnly, +PowerDown
15. 0078: Code 1B, link 06
02 01 21 B5 1E 4D
Tuple CISTPL_CFTABLE_ENTRY (1B), length 6 (06) at offset 78
 - Configuration Table Index is 02
 - Vcc Power Description: Nom V = 3.30 V, Peak I = 45.0 mA

16. 0080: Code 1B, link 0F
C3 41 99 01 55 EA 61 70 01 07 76 03 01 EE 20
Tuple CISTPL_CFTABLE_ENTRY (1B), length 15 (0F) at offset 80
 - Configuration Table Index is 03 (default)
 - Interface type is I/O
 - BVDs not active, WP not active, RdyBsy active
 - Wait signal support not required
 - Vcc Power Description: Nom V = 5.0 V
 - Decode 10 I/O lines, bus size 8 or 16
 - I/O block at 0170, length 8
 - I/O block at 0376, length 2
 - IRQ may be shared, pulse and level mode interrupts are supported
 - Only IRQ14 is supported
 - Miscellaneous Features: Max Twins 0, -Audio, -ReadOnly, +PowerDown
17. 0091: Code 1B, link 06
03 01 21 B5 1E 4D
Tuple CISTPL_CFTABLE_ENTRY (1B), length 6 (06) at offset 91
 - Configuration Table Index is 03
 - Vcc Power Description: Nom V = 3.30 V, Peak I = 45.0 mA
18. 0099: Code 14, link 00
Tuple CISTPL_NO_LINK (14), length 0 (00) at offset 99
19. 009B: Code FF
Tuple CISTPL_END (FF) at offset 9B

5.4 Identify Drive Parameter

An example of the parameter information received from the CF Card when invoking the Identify Drive command (ECh) is listed in Table 26.

Table 26: Identify Drive Parameter

Word	Hex	Data Field Type Information	Description
0	8484Ah	General Configuration	<ol style="list-style-type: none"> 1. Configuration Flag indicates Word 0 shall be 8484Ah 2. Removable Media Device: the Card contains media that can be removed during Card operation 3. Not Removable Controller and/or Device: the Card is intended to be removable during operation
1	XXXXh	Default Number of Cylinders	Number of translated cylinders in the default translation mode
2	0000h	Reserved	-
3	XXXXh	Default Number of Heads	Number of translated heads in the default translation mode
4	0000h	Obsolete	-
5	0200h	Obsolete	-
6	XXXXh	Default Number of Sectors per Track	Number of sectors per track in the default translation mode
7-8	2 @ XXXXh	Number of Sectors per Card	Number of sectors per Card This double word value is also the first invalid address in LBA translation mode
9	0000h	Obsolete	-
10-19	Unique	Serial Number	STEC Proprietary
20-21	2 @ 0000h	Obsolete	-
22	0004h	ECC Count	Number of ECC bytes (4) used on each sector in the Read and Write Long commands
23-26	4 Words	Firmware Revision (8 ASCII Characters)	Reserved
27-46	20 Words	Model Number (40 ASCII Characters)	Reserved
47	0001h	Read/Write Multiple Sector Count	<ol style="list-style-type: none"> 1. Permitted value 2. Maximum number of sectors per block (1) that the Card supports for Read/Write Multiple commands
48	0000h	Reserved	-
49	2B00h	Capabilities	<ol style="list-style-type: none"> 1. Standby Timer operation is supported and defined by IDLE command 2. Card may support IORDY operation 3. IORDY may not be disabled 4. Card supports LBA mode addressing 5. Read DMA and Write DMA commands are supported

Word	Hex	Data Field Type Information	Description
50	0000h	Reserved	-
51	0200h	PIO Data Transfer Cycle Timing Mode	PIO mode 2
52	0000h	Obsolete	-
53	0007h	Translation Parameters Valid	<ol style="list-style-type: none"> Words 54 to 58 are valid and reflect the current number of cylinders, heads and sectors Words 64 through 70 are valid Word 88 is valid and reflects the supported True IDE UDMA transfer modes
54-56	3 @ XXXXh	Current Number of Cylinders, Heads, Sectors/Track	Number of user addressable Cylinders, Heads, and Sectors/Track in the current translation mode
57-58	2 @ XXXXh	Current Capacity	Capacity = Cylinders x Heads x Sectors
59	0101h	Multiple Sector Setting	<ol style="list-style-type: none"> Multiple Sector Setting is valid Current setting for the number of sectors (1) that shall be transferred per interrupt on Read/Write Multiple commands
60-61	2 @ XXXXh	Total Sectors Addressable in LBA Mode	Total number of user addressable sectors for the Card in LBA mode only
62	0000h	Reserved	-
63	0007h	Multiword DMA Transfer	<ol style="list-style-type: none"> Multiword DMA modes 2, 1 and 0 are supported Multiword DMA modes 1 and 0 are supported Multiword DMA is supported
64	0003h	Advanced PIO transfer modes supported	<ol style="list-style-type: none"> PIO mode 3 is supported PIO mode 4 is supported
65	0078h	Minimum Multiword DMA transfer cycle time	120ns
66	0078h	Recommended Multiword DMA transfer cycle time	120ns
67	0078h	Minimum PIO transfer cycle time without flow control	120ns
68	0078h	Minimum PIO transfer cycle time with IORDY	120ns
69-79	11 @ 0000h	Reserved	-
80	0078h	Reserved	-
81	0000h	Reserved	-

Word	Hex	Data Field Type Information	Description
82	740Ah	Features/command sets supported	<ol style="list-style-type: none"> 1. NOP command is supported 2. Read Buffer command is supported 3. Write Buffer command is supported 4. Host Protected Area feature set is supported 5. Device Reset command is not supported 6. Service interrupt is not supported 7. Release interrupt is supported 8. Look-ahead is not supported 9. Write cache is not supported 10. Packet Command feature set is not supported 11. Power Management feature set is supported 12. Removable Media feature set is not supported 13. Security Mode feature set is supported 14. SMART feature set is not supported <p>Note: The card is SMART ready and the SMART feature set can be implemented per special request.</p>
83	4004h	Features/command sets supported	<ol style="list-style-type: none"> 1. Removable Media Status feature set is not supported 2. Advanced Power Management feature set is not supported 3. CFA feature set is supported 4. Read DMA Queued and Write DMA Queued commands are not supported 5. Download Microcode command is not supported
84	4000h	Reserved	-
85	7428h	Features/command sets enabled	<ol style="list-style-type: none"> 1. NOP command is supported 2. Read Buffer command is supported 3. Write Buffer command is supported 4. Host Protected Area feature set is supported 5. Device Reset command is not supported 6. Service interrupt is not enabled 7. Release interrupt is not enabled 8. Look-ahead is not enabled 9. Write cache is enabled 10. Packet Command feature set is not enabled 11. Power Management feature set is supported 12. Removable Media feature set is not supported 13. Security Mode feature set has not been enabled via the Security Set Password command 14. SMART feature set is not enabled <p>Note: The card is SMART ready and the SMART feature set can be implemented per special request.</p>

Word	Hex	Data Field Type Information	Description
86	0004h	Features/command sets enabled	<ol style="list-style-type: none"> 1. Removable Media Status feature set is not supported 2. Advanced Power Management feature set has not been enabled via the Set Features command 3. CFA feature set is supported 4. Read DMA Queued and Write DMA Queued commands are not supported 5. Download Microcode command not supported
87	4000h	Reserved	-
88	041Fh	True IDE Ultra DMA Modes Supported and Selected	<ol style="list-style-type: none"> 1. Ultra DMA mode 6 is not selected 2. Ultra DMA mode 5 is not selected 3. Ultra DMA mode 4 is not selected 4. Ultra DMA mode 3 is not selected 5. Ultra DMA mode 2 is selected 6. Ultra DMA mode 1 is not selected 7. Ultra DMA mode 0 is not selected 8. Ultra DMA mode 6 and below are not supported 9. Ultra DMA mode 5 and below are not supported 10. Ultra DMA mode 4 and below are supported 11. Ultra DMA mode 3 and below are supported 12. Ultra DMA mode 2 and below are supported 13. Ultra DMA mode 1 and below are supported 14. Ultra DMA mode 0 is supported
89	0000h	Time required for Security erase unit completion	Not specified
90	0000h	Time required for Enhanced security erase unit completion	Not specified
91	0000h	Advanced power management level value	Not specified
92	FFFEh	Reserved	-
93-127	35 @ 0000h	Reserved	-
128	0001h	Security Status	<ol style="list-style-type: none"> 1. Security level is high 2. Enhanced security erase unit feature set is not supported 3. Security count has not expired 4. Security is not Frozen 5. Security is unlocked 6. Security is disabled 7. Security mode feature set supported
129-159	31 @ 0000h	Vendor Unique Bytes	Reserved

Word	Hex	Data Field Type Information	Description
160	0000h	Power Requirement Description	<ol style="list-style-type: none"> 1. Word does not contain a power requirement description 2. Card has Power Level 1 commands 3. Power Level 1 commands are enabled 4. Maximum current: Not specified
161	0000h	Reserved	-
162	0000h	Key Management Schemes Supported	Device does not support CPRM
163	0492h	CF Advanced True IDE Timing Mode Capabilities and Settings	<ol style="list-style-type: none"> 1. Current Multiword DMA timing Mode 4 selected: 2. Current PIO timing Mode 6 selected 3. Maximum Multiword DMA Timing Mode 4 supported 4. Maximum PIO Mode 6 Timing supported
164	A91Ah	CF Advanced PC Card I/O and Memory Timing Modes Capabilities and Settings	<ol style="list-style-type: none"> 1. PC Card UDMA support values in bits 11-6 are valid 2. PC Card Memory or I/O UDMA timing Mode 2 selected 3. Maximum PC Card Memory UDMA timing Mode 4 supported 4. Maximum PC Card I/O UDMA timing Mode 4 supported 5. Maximum Memory timing mode supported: 80 ns 6. Maximum PC Card IO timing mode supported: 100 ns
165-255	90 @ 0000h	Reserved	-

6.0 Registers

This chapter lists the registers of the CF Card. Refer to CompactFlash standards for further details.

6.1 Configuration Registers

In PC Card Mode, four configuration registers, as listed in Table 27, are used.

Note: In True IDE Mode, these registers cannot be used.

Table 27: Configuration Registers

Configuration Register	Description
Configuration Option Register	This register is used to configure and observe the status of the CF Card, and to issue soft resets to it. Also, the Index bits of this register are used to select the PC Card mapping mode that the CF Card uses: 1) PC Card Memory, 2) PC Card Contiguous I/O, 3).PC Card Primary I/O, and 4) PC Card Secondary I/O
Configuration and Status Register	This register is used for observing the CF Card state.
Pin Replacement Register	This register is used for providing the signal state of -IREQ when the CF Card is configured in the PC Card I/O Mode.
Socket and Copy Register.	This read/write register is used to identify the CF Card from other devices. This register should be set by the host before this Configuration Option register is set.

6.2 Task File Registers

Table 28: CF Card Task File Registers

Task File Register	Description
Data Register	The Data Register is a 16-bit read/write register used for transferring data between the CF Card and the host. This register can be accessed in word mode and byte mode.
Error Register	The Error Register is a read-only register that is used for analyzing an error. This register is valid when the BSY bit in the Status register and Alternate Status register are set to "0" (Ready). Diagnostic Codes are returned in the Error Register after a Execute Drive Diagnostic command (code 90h). Extended Error Codes returned in the Error Register after an Request Sense command (code 03h).
Sector Count Register	This register contains the numbers of sectors of data requested to be transferred on a read or write operation between the host and the CF Card. If the value in the register is 0, a count of 256 sectors is indicated.
Sector Number Register	When the LBA bit in the Drive/Head register is 0, this register contains the starting sector number for any media access. When the LBA bit is set to 1, this register contains bits 7:0 of the LBA for any media access.
Cylinder Low Register	In CHS mode (LBA=0), this register contains the low-order bits of the starting cylinder address. In LBA mode, it contains bits 15:8 of the LBA.
Cylinder High Register	In CHS mode (LBA=0), this register contains the high-order bits of the starting cylinder address. In LBA mode, it contains bits 23:16 of the LBA.
Drive/Head Register	This register selects the CF Card address translation (CHS or LBA) and provides head address (CHS) or high-order address bits 27:24 for LBA.
Status Register	This read-only register indicates status of a command execution. When the BSY bit is "0", the other bits are valid; when the BSY bit is "1", the other bits are not valid. When the register is read, the interrupt pin, is cleared.
Alternate Status Register	This register is the same as the Status register, except that is not negated when the register is read.
Device Control Register	This write-only register is used for controlling the interrupt request and issuing an ATA soft reset to the CF Card.
Drive Address Register	This read-only register is used for confirming the CF Card's status. This register is provided for compatibility with the AT disk drive interface and it is not recommended that this register be mapped into the host's I/O space because of potential conflicts on bit 7.
Command Register	This write-only register is used for writing the command that executes the CF Card's operation. The command code is written in the command register after its parameters are written in the Task File during the CF Card ready state.

7.0 Supported ATA Commands

The ATA commands used by the CF Card are listed in Table 29. Refer to CompactFlash standards for details.

Table 29: CF Card Supported ATA Commands

Command Set	Code	Description
Check Power Mode	E5h or 98h	This command checks the power mode.
Execute Drive Diagnostic	90h	Command performs internal diagnostic tests implemented by the CF Card. Diagnostic Code is returned in Error Register.
Erase Sector(s)	C0h	Cmd is used to pre-erase/condition data sectors in advance.
Format Track	50h	This command writes the desired head and cylinder of the selected drive with a vendor unique data pattern (typically 00h or FFh). Card accepts a sector buffer of data from the host to follow the command with the same protocol as the Write Sector Command although the information in the buffer is not used.
Identify Drive	ECh	This command lets the host receive parameter information from the CF Card in the same protocol as Read Sector(s) command.
Idle	E3h or 97h	Command causes the CF Card to set BSY, enter the Idle mode, clear BSY, and generate an interrupt. If the sector count is non-zero, automatic power down mode is enabled. If the sector count is zero, the automatic power down mode is disabled.
Idle Immediate	E1h or 95h	This command causes the CF Card to set BSY, enter the Idle mode, clear BSY, and generate an interrupt.
Initialize Drive Parameters	91h	This command enables the host to set the number of sectors per track and the number of heads per cylinder.
NOP	00h	No Operation.
Read Buffer	E4h	Command enables host to read contents of card's sector buffer.
Read DMA	C8h	If UDMA is enabled, this command is the sector read command used for UDMA transfer. If UDMA is not enabled, this command is the sector read command used for MWDMA transfer
Read Multiple	C4h	This command performs similarly to the Read Sectors command. Interrupts are not generated on each sector, but on the transfer of a block which contains the number of sectors defined by a Set Multiple command.
Read Long Sector	22h or 23h	Command performs similarly to the Read Sector(s) command except that it returns 516 bytes of data instead of 512 bytes.
Read Sector(s)	20h (w/ retry) 21h (w/o retry)	Command reads from 1 to 256 sectors as specified in Sector Count register. A sector count of 0 requests 256 sectors. Transfer begins at sector specified in Sector Number register.

Command Set	Code	Description
Read Verify Sector(s)	40h (w/ retry) 41h (w/o retry)	This command verifies one or more sectors on the CF Card by transferring data from the flash media to the data buffer in the CF Card and verifying that the ECC is correct. This command is identical to the Read Sectors command, except that DRQ is never set and no data is transferred to the host.
Recalibrate	1Xh	The CF Card performs only the interface timing and register operations. When this command is issued, the CF Card sets BSY and waits for an appropriate length of time, after which it clears BSY and issues an interrupt. When this command ends normally, the CF Card is initialized.
Request Sense (Extended Error)	03h	Command requests extended error code after command ends with error. Extended error code is returned in Error Register.
Seek	7Xh	This command is effectively a NOP command to the CF Card although it does perform a range check.
Set Features	EFh	Command is used by the host to establish or select features.
Set Multiple Mode	C6h	Command enables card to perform multiple read and write operations and establishes block count for these commands.
Set Sleep Mode	E6h or 99h	This is the only command that allows the host to set the CF Card into Sleep mode. When the CF Card is set to sleep mode, the CF Card clears the BSY line and issues an interrupt. The CF Card enters sleep mode and the only method to make the CF Card active again (back to normal operation) is by performing a hardware reset or a software reset.
Stand By	E2h or 96h	This command sets the CF Card in Standby mode. If the Sector Count Register is a value other than 0H, an Auto Power Down is enabled and when the CF Card returns to the idle mode, the timer starts a countdown. Time is set in Sector Count Register.
Stand By Immediate	E0h or 94h	This command causes the CF Card to set BSY, enter the Standby mode, clear BSY and return the interrupt immediately.
Translate Sector	87h	This command allows the host a method of determining the exact number of times a user sector has been erased and programmed. This command is not supported.
Wear Level	F5h	Command is effectively a NOP command and only implemented for backward compatibility. The Sector Count Register is always returned with a 00h indicating Wear Level is not needed.
Write Buffer	E8h	This command enables the host to overwrite the contents of the CF Card's sector buffer with any data pattern desired.
Write DMA	CAh	If UDMA is enabled, this command is the sector write command used for UDMA transfer. If UDMA is not enabled, this command is the sector write command used for MWDMA transfer.
Write Long Sector	32h or 33h	This command is provided for compatibility purposes and is similar to the Write Sector(s) command except that it writes 516 bytes instead of 512 bytes.

Command Set	Code	Description
Write Multiple	C5h	Command is similar to the Write Sectors command. Interrupts are not presented on each sector, but on transfer of block which contains number of sectors defined by Set Multiple command.
Write Multiple w/o Erase	CDh	This command is similar to the Write Multiple command, except that an implied erase before the write operation is not performed. Note: Before using this command, it is required to erase the respective sectors using the Erase Sectors command
Write Sector(s)	30h (w/ retry) 31h (w/o retry)	This command writes from 1 to 256 sectors as specified in the Sector Count register. A sector count of zero requests 256 sectors. The transfer begins at the sector specified in the Sector Number register.
Write Sector(s) w/o Erase	38h	This command is similar to the Write Sector(s) command, except that an implied erase before the write operation is not performed. Note: Before using this command, it is required to erase the respective sectors using the Erase Sectors command.
Write Verify	3Ch	This command is similar to the Write Sector(s) command except each sector is verified immediately after being written.

8.0 SMART Feature Set

Self-Monitoring, Analysis, and Reporting Technology (the SMART feature set) is used to protect the user from unscheduled downtime. By monitoring and storing critical performance and calibration parameters, SMART feature set devices attempt to predict the likelihood of near-term degradation or fault condition. Informing the host system of a negative reliability condition allows the host system to warn the user of the impending risk of a data loss and advise the user of appropriate action.

Note: The CF Card is SMART ready and the SMART feature set can be implemented per special request.

8.1 SMART Support and Identify Command

Support for the SMART feature set is indicated by the Identify Command response as follows:

- Word 82 bit 0 – a “1” indicates that SMART feature set is supported.
- Word 84 bit 1 – a “0” indicates that SMART self test not supported.
- Word 84 bit 0 – a “0” indicates SMART error logging not supported.
- Word 85 bit 0 – a “1” indicates SMART feature set has been enabled via the SMART ENABLE OPERATIONS command, and a “0” indicates the SMART feature set has been disabled via the SMART DISABLE OPERATIONS command

The CF Card does not support SMART self test or error logging. The following indicators for the SMART feature set are set to 0:

- Word 87 bit 1 – a 0 indicates that SMART self test is not enabled.
- Word 87 bit 0 – a 0 indicates that SMART error logging is not enabled.

8.2 SMART Commands

A command code of 0xB0 with a SMART command selected in the Feature Register invokes a SMART command. Refer to Table 30 for the Feature Register values associated with each SMART command.

Table 30: Supported SMART Commands

Feature Register	Command	Notes
D0h	SMART READ ATTRIBUTE DATA	Optional – supported
D1h	SMART READ ATTRIBUTE THRESHOLDS	OBS – supported
D2h	SMART ENABLE/DISABLE ATTRIBUTE AUTOSAVE	Mandatory
D8h	SMART ENABLE OPERATIONS	Mandatory
D9h	SMART DISABLE OPERATIONS	Mandatory
DAh	SMART RETURN STATUS	Mandatory

8.3 SMART Attributes

The SMART attributes used by the card are listed in Table 31.

Table 31: CF Card Supported SMART Attributes

ID	Name	Description	Type
9	Power On Hours	Number of hours elapsed in the Power-On state.	Advisory
12	Power Cycle	Number of power-on events.	Advisory
13	Soft Read Error Rate	Number of corrected read errors reported to the operating system (SLC = 3 or more bits; MLC =5 or more bits).	Advisory
100	Erase/Program Cycles	Count of erase program cycles for entire card.	Advisory
170	Reserved Block Count	Number of reserved spares for bad block handling.	Warranty
187	Reported Uncorrectable Errors	Number of uncorrectable errors reported at the interface.	Advisory
188	Command Timeout	Tracks the number of command time outs as defined by an active command being interrupted.	Advisory
199	UDMA CRC Error	Number of CRC errors during UDMA mode.	Advisory

9.0 Appendix: CompactFlash Adapter

In addition to the CF Card form factors, passive CompactFlash Adapters allow the card to be used in a PC Card Type II slot. This appendix provides information on the CompactFlash Adapter available from STEC.

9.1 CF Adapter Ordering Information

Refer to Table 32 for the CF Adapter ordering part number.

Table 32: CF Adapter Ordering Information

Part Number	CF Form Factor	PC Card Form Factor
SLCFADU	Type I	Type II

Legend:

- **SLCFAD** = STEC standard CompactFlash Adapter part number prefix.
- **Part numbers without (I)** = Commercial temperature range (0°C to 70°C).
- **U** = RoHS-6 compliant lead-free.

9.2 CF Adapter Specifications

Table 33: CF Adapter Specifications

Parameter	Value
Mating/unmating life	10,000 cycles
Operating voltage	240 VAC max
Current rating	1A max
Contact resistance	3 ohms max
Insulation resistance	200M ohms min (300V DC)
Commercial Operating Temperature	0°C to 70°C
Lead content	RoHS-6 compliant, lead-free

9.3 CF Adapter Package Dimensions and Pin Locations

Table 34 and Figure 21 show the mechanical dimensions of the CF Adapter Type I.

Table 34: Mechanical dimensions CF Adapter Type I

Parameter	Value
Length	85.50 ± 0.20 mm (3.366 ± 0.008 in)
Width	54.40 ± 0.10 mm (2.126 ± 0.004 in)
Height (including label area)	5.00 mm (0.197 in) max

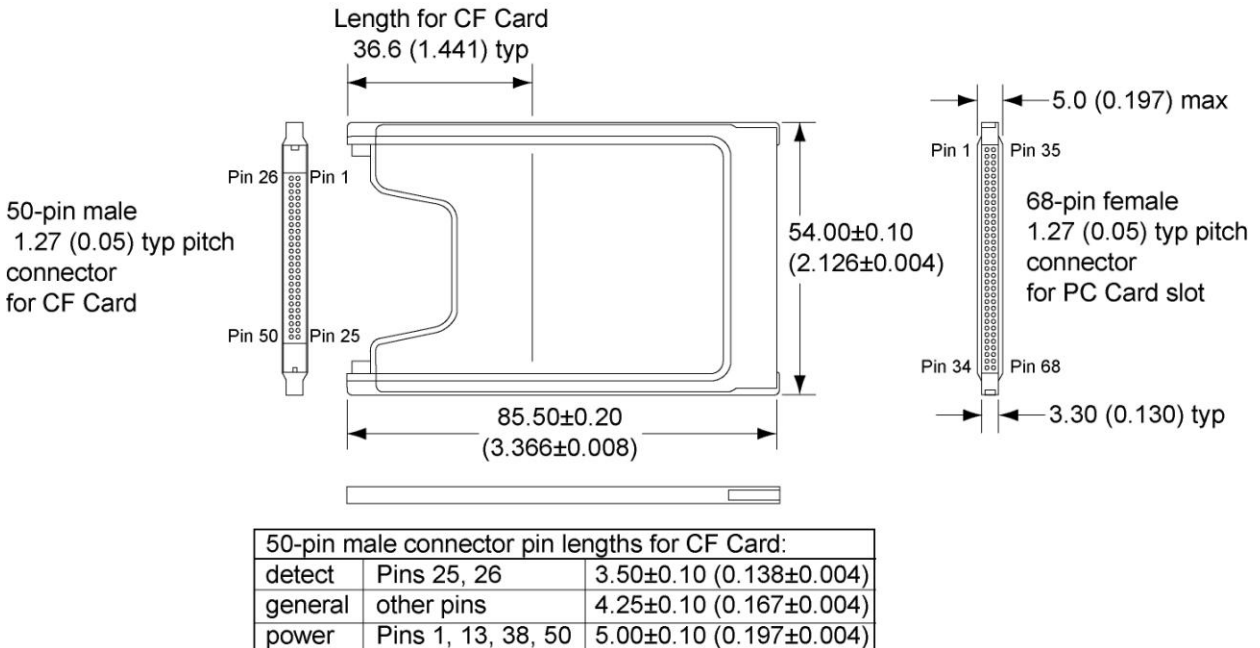

Figure 21: Mechanical dimensions CF Adapter Type I

9.4 CF Adapter Pin Assignment

Table 35: CF Adapter Pin Assignment

Pin Number	PC Card	CF Card	Pin Number	PC Card	CF Card
1	GND	GND	35	GND	-IOWR, STOP
2	D03	D03	36	-CD1	-WE
3	D04	D04	37	D11	-RDY/-BSY, -IREQ, INTRQ
4	D05	D05	38	D12	VCC
5	D06	D06	39	D13	-CSEL
6	D07	D07	40	D14	-VS2
7	-CE1, -CS0	-CE1, -CS0	41	D15	(-)RESET
8	A10	A10	42	-CE2, -CS1	-WAIT, IORDY, -DDMARDY, DSTROBE
9	-OE, -ATASEL	-OE, -ATASEL	43	-VS1	-INPACK, (-)DMARQ
10		A09	44	-IORD	-REG, (-)DMACK
11	A09	A08	45	-IOWR, STOP	BVD2, -SPKR, -DASP
12	A08	A07	46		BVD1, -STSCHG, -PDIAG
13		VCC	47		D08
14		A06	48		D09
15	-WE	A05	49		D10
16	-RDY/-BSY, -IREQ, INTRQ	A04	50		GND
17	VCC	A03	51	VCC	
18		A02	52		
19		A01	53		
20		A00	54		
21		D00	55		
22	A07	D01	56		
23	A06	D02	57	-VS2	
24	A05	WP, -IOIS16	58	(-)RESET	
25	A04	-CD2	59	-WAIT, IORDY -DDMARDY, DSTROBE	
26	A03	-CD1	60	-INPACK, (-)DMARQ	
27	A02	D11	61	-REG, (-)DMACK	
28	A01	D12	62	BVD2, -SPKR, -DASP	
29	A00	D13	63	BVD1, -STSCHG, -PDIAG	
30	D00	D14	64	D08	
31	D01	D15	65	D09	
32	D02	-CE2, -CS1	66	D10	
33	WP, -IOIS16, -IOCS16	-VS1	67	-CD2	
34	GND	-IORD, HSTROBE, (-)HDMARDY	68	GND	

Legend: "-" = Low active

10.0 Revision History

Revision	Date	Description
-101	10/1/08	Preliminary release.
-102	12/12/08	Endurance added to Features and Reliability table.
-103	1/9/09	Signal description of D15-D00 corrected.
-104	2/12/09	Note added in Ordering Information that cards are shipped unformatted.
-105	2/18/09	Capacity in Features, Performance table, CHS Parameter table, and Word 88 in ID table corrected.
-106	3/17/09	MTBF added to reliability table. Storage temperature corrected.
-107	3/23/09	Preliminary notice removed.
-108	4/24/09	ID Table updated and SMART Feature Set added.

DISCLAIMER OF LIABILITY

STEC™ Inc. reserves the right to make changes to specifications and product descriptions such as but not limited to numbers, parameters and other technical information contained herein without notice. Please contact the STEC™ Inc. sales office to obtain the latest specifications. STEC™ Inc. grants no warranty with respect to this datasheet, neither explicit or implied, and is not liable for direct or indirect damages. Some states do not grant the exclusion of incidental damages and as such this statement may not be valid in such states. The provisions of the datasheet do not convey to the purchaser of the device any license under any patent rights or other intellectual property rights of STEC Inc. or others.

EXPORT ADMINISTRATION REGULATIONS

The information provided may be subject to United States Export Controls. Such information should not be downloaded or exported (i), into (or to a national or resident of) Cuba, Iraq, Libya, North Korea, Iran, Syria, or any other country to which the United States has embargoed goods; or given to (ii), anyone on the United States Treasury Department's list of Specially Designated Nationals or the U.S. Commerce Department's Table of Deny Orders. By using the information, you represent and warrant that you are not located in, under the control of, or a national or resident of any such country or on any such list.

COPYRIGHT NOTICE

Copyright © 2009 by STEC™ Inc. All rights reserved. Information contained in this document, including but not limited to any instructions, descriptions and product specifications, is considered proprietary and confidential to STEC™, Inc. and shall not be modified, used, copied, reproduced or disclosed in whole or in part, in any form or by any means, electronic or mechanical, for any purpose, without the written consent of STEC™ Inc

Worldwide Headquarters

STEC, Inc.
3001 Daimler Street
Santa Ana, California 92705 USA
Tel: (949) 476-1180
Fax: (949) 476-1209
www.stec-inc.com/

STEC Europe

Donau-City-Strasse 1
1220 Vienna, Austria
Tel: +43 1 263 38 08
Fax: +43 1 263 37 65
www.stec-inc.com/

STEC Japan

Arents Daikanyama 114
11-1 Hachiyama-cho
Shibuya-ku, Tokyo
150-0035 Japan
Tel: +81(0) 3-5428-2231
Tel: +81(0) 3-5489-0230
www.stec-inc.jp/

STEC Malaysia

STEC Techology Sdn Bhd
Plot 107 Bayan Lepas Industrial Park
Phase 4, 11900 Penang, Malaysia
Tel: +60 (4)-6198888
www.stec-inc.com/

STEC China

RM1805, 18F Bund Centre
222 Yan An Rd East
HuangPu District
Shanghai, 200002.
P R. China
Tel: +86 21 6132 3892 * 629
Fax: +86 21 6335 1336
www.stecchina.cn/

