

16K/32K x 9 Deep Sync FIFOs

Features

- High speed, low power, first-in first-out (FIFO) memories
- 16K × 9 (CY7C4261)
- 32K × 9 (CY7C4271)
- 0.5 micron CMOS for optimum speed and power
- High speed 100 MHz operation (10 ns read/write cycle times)
- Low power — $I_{CC} = 35$ mA
- Fully asynchronous and simultaneous read and write operation
- Empty, Full, Half Full, and programmable Almost Empty and Almost Full status flags
- TTL compatible
- Output Enable (\overline{OE}) pins
- Independent read and write enable pins
- Center power and ground pins for reduced noise
- Supports free running 50% duty cycle clock inputs
- Width Expansion Capability
- Military temp SMD Offering – CY7C4271-15LMB
- 32-pin PLCC/LCC and 32-pin TQFP
- Pin compatible density upgrade to CY7C42X1 family
- Pin compatible density upgrade to IDT72201/11/21/31/41/51
- Pb-Free Packages Available

Selection Guide

Parameter		7C4261/71-10	7C4261/71-15	7C4261/71-25	7C4261/71-35	Unit
Maximum Frequency		100	66.7	40	28.6	MHz
Maximum Access Time		8	10	15	20	ns
Minimum Cycle Time		10	15	25	35	ns
Minimum Data or Enable Setup		3	4	6	7	ns
Minimum Data or Enable Hold		0.5	1	1	2	ns
Maximum Flag Delay		8	10	15	20	ns
Active Power Supply Current (I_{CC1})	Commercial	35	35	35	35	mA
	Industrial/Military	40	40	40	40	

Parameter	CY7C4261	CY7C4271
Density	16K × 9	32K × 9
Package	32-pin PLCC, TQFP	32-pin LCC, PLCC, TQFP

Functional Description

The CY7C4261/71 are high speed, low power FIFO memories with clocked read and write interfaces. All are nine bits wide. The CY7C4261/71 are pin compatible to the CY7C42X1 Synchronous FIFO family. The CY7C4261/71 can be cascaded to increase FIFO width. Programmable features include Almost Full/Almost Empty flags. These FIFOs provide solutions for a wide variety of data buffering needs, including high speed data acquisition, multiprocessor interfaces, and communications buffering.

These FIFOs have 9-bit input and output ports that are controlled by separate clock and enable signals. The input port is controlled by a free-running clock (WCLK) and two write-enable pins (WEN1, WEN2/LD).

When $\overline{WEN1}$ is LOW and WEN2/LD is HIGH, data is written into the FIFO on the rising edge of the WCLK signal. While WEN1, WEN2/LD is held active, data is continually written into the FIFO on each WCLK cycle. The output port is controlled in a similar manner by a free running read clock (RCLK) and two read enable pins ($\overline{REN1}$, $\overline{REN2}$). In addition, the CY7C4261/71 has an output enable pin (\overline{OE}). The read (RCLK) and write (WCLK) clocks may be tied together for single-clock operation or the two clocks may be run independently for asynchronous read/write applications. Clock frequencies up to 100 MHz are achievable. Depth expansion is possible using one enable input for system control, while the other enable is controlled by expansion logic to direct the flow of data.

Logic Block Diagram

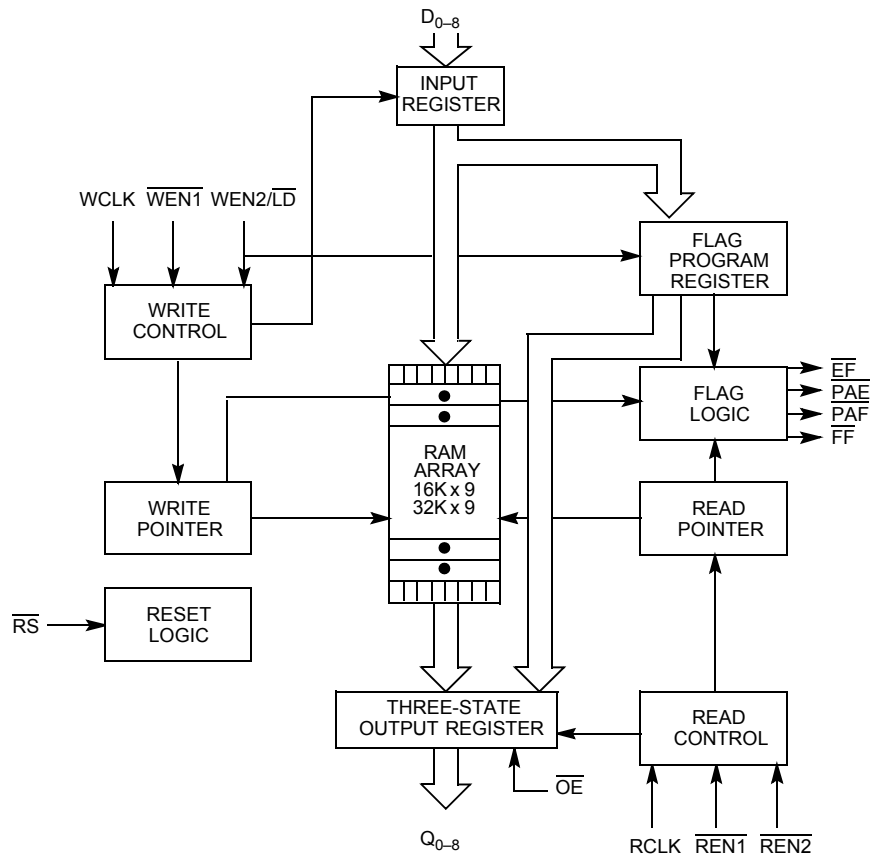

Pinouts

Figure 1. Pin Diagram - 32-Pin PLCC/LCC (Top View)

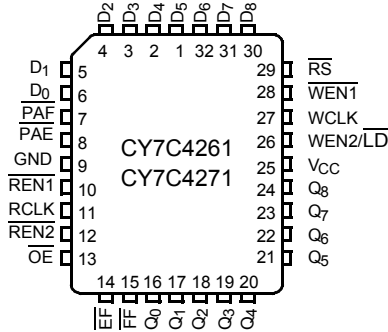

Figure 2. Pin Diagram - 32-Pin TQFP (Top View)

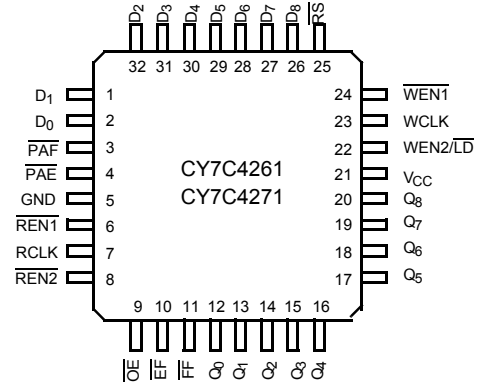

Table 1. Pin Definitions - 32-Pin Device

Signal Name	Description	IO	Description
D ₀₋₈	Data Inputs	I	Data Inputs for 9-bit bus.
Q ₀₋₈	Data Outputs	O	Data Outputs for 9-bit bus.
WEN1	Write Enable 1	I	The only write enable when device is configured to have programmable flags. Data is written on a LOW-to-HIGH transition of WCLK when WEN1 is asserted and FF is HIGH. If the FIFO is configured to have two write enables, data is written on a LOW-to-HIGH transition of WCLK when WEN1 is LOW and WEN2/LD and FF are HIGH.
WEN2/LD Dual Mode Pin	Write Enable 2 Load	I	If HIGH at reset, this pin operates as a second write enable. If LOW at reset, this pin operates as a control to write or read the programmable flag offsets. WEN1 must be LOW and WEN2 must be HIGH to write data into the FIFO. Data is not written into the FIFO if the FF is LOW. If the FIFO is configured to have programmable flags, WEN2/LD is held LOW to write or read the programmable flag offsets.
REN1, REN2	Read Enable Inputs	I	Enables the device for Read operation. Both REN1 and REN2 must be asserted to allow a read operation.
WCLK	Write Clock	I	The rising edge clocks data into the FIFO when WEN1 is LOW and WEN2/LD is HIGH and the FIFO is not Full. When LD is asserted, WCLK writes data into the programmable flag-offset register.
RCLK	Read Clock	I	The rising edge clocks data out of the FIFO when REN1 and REN2 are LOW and the FIFO is not Empty. When WEN2/LD is LOW, RCLK reads data out of the programmable flag-offset register.
EF	Empty Flag	O	When EF is LOW, the FIFO is empty. EF is synchronized to RCLK.
FF	Full Flag	O	When FF is LOW, the FIFO is full. FF is synchronized to WCLK.
PAE	Programmable Almost Empty	O	When PAE is LOW, the FIFO is almost empty based on the almost empty offset value programmed into the FIFO. PAE is synchronized to RCLK.
PAF	Programmable Almost Full	O	When PAF is LOW, the FIFO is almost full based on the almost full offset value programmed into the FIFO. PAF is synchronized to WCLK.
RS	Reset	I	Resets device to empty condition. A reset is required before an initial read or write operation after power up.
OE	Output Enable	I	When OE is LOW, the FIFO's data outputs drive the bus to which they are connected. If OE is HIGH, the FIFO's outputs are in High Z (high impedance) state.

Functional Description

The CY7C4261/71 provides four status pins: Empty, Full, Programmable Almost Empty, and Programmable Almost Full. The Almost Empty/Almost Full flags are programmable to single word granularity. The programmable flags default to Empty + 7 and Full – 7.

The flags are synchronous, that is, they change state relative to either the read clock (RCLK) or the write clock (WCLK). When entering or exiting the Empty and Almost Empty states, the flags are updated exclusively by the RCLK. The flags denoting Almost Full, and Full states are updated exclusively by WCLK. The synchronous flag architecture guarantees that the flags maintain their status for at least one cycle.

All configurations are fabricated using an advanced 0.5µ CMOS technology. Input ESD protection is greater than 2001V, and latch-up is prevented by the use of guard rings.

Architecture

The CY7C4261/71 consists of an array of 16K to 32K words of nine bits each (implemented by a dual port array of SRAM cells), a read pointer, a write pointer, control signals (RCLK, WCLK, REN1, REN2, WEN1, WEN2, RS), and flags (EF, PAE, PAF, FF).

Resetting the FIFO

Upon power up, the FIFO must be reset with a Reset (\overline{RS}) cycle. This causes the FIFO to enter the Empty condition signified by EF being LOW. All data outputs (Q_{0-8}) go LOW t_{RSF} after the rising edge of RS. For the FIFO to reset to its default state, a falling edge must occur on \overline{RS} and the user must not read or write while RS is LOW. All flags are guaranteed to be valid t_{RSF} after RS is taken LOW.

FIFO Operation

When the $\overline{WEN1}$ signal is active LOW, WEN2 is active HIGH, and FF is active HIGH, data present on the D_{0-8} pins is written into the FIFO on each rising edge of the WCLK signal. Similarly, when the REN1 and REN2 signals are active LOW and EF is active HIGH, data in the FIFO memory is presented on the Q_{0-8} outputs. New data is presented on each rising edge of RCLK while REN1 and REN2 are active. REN1 and REN2 must set up t_{ENS} before RCLK for it to be a valid read function. WEN1 and WEN2 must occur t_{ENS} before WCLK for it to be a valid write function.

An output enable (\overline{OE}) pin is provided to three-state the Q_{0-8} outputs when OE is asserted. When OE is enabled (LOW), data in the output register is available to the Q_{0-8} outputs after t_{OE} . If devices are cascaded, the OE function only outputs data on the FIFO that is read enabled.

The FIFO contains overflow circuitry to disallow additional writes when the FIFO is full, and underflow circuitry to disallow additional reads when the FIFO is empty. An empty FIFO maintains the data of the last valid read on its Q_{0-8} outputs even after additional reads occur.

Write Enable 1 ($\overline{WEN1}$). If the FIFO is configured for programmable flags, Write Enable 1 ($\overline{WEN1}$) is the only write enable control pin. In this configuration, when Write Enable 1 ($\overline{WEN1}$) is LOW, data can be loaded into the input register and RAM array on the LOW-to-HIGH transition of every write clock (WCLK). Data is stored in the RAM array sequentially and independently of any on-going read operation.

Write Enable 2/Load ($\overline{WEN2/LD}$). This is a dual purpose pin. The FIFO is configured at Reset to have programmable flags or to have two write enables, which allows for depth expansion. If Write Enable 2/Load ($\overline{WEN2/LD}$) is set active HIGH at Reset ($RS = LOW$), this pin operates as a second write enable pin.

If the FIFO is configured to have two write enables, when Write Enable ($\overline{WEN1}$) is LOW and Write Enable 2/Load ($\overline{WEN2/LD}$) is HIGH, data can be loaded into the input register and RAM array on the LOW-to-HIGH transition of every write clock (WCLK). Data is stored in the RAM array sequentially and independently of any ongoing read operation.

Programming

When $\overline{WEN2/LD}$ is held LOW during Reset, this pin is the load (\overline{LD}) enable for flag offset programming. In this configuration, $\overline{WEN2/LD}$ can be used to access the four 8-bit offset registers contained in the CY7C4261/71 for writing or reading data to these registers.

When the device is configured for programmable flags and both $\overline{WEN2/LD}$ and $\overline{WEN1}$ are LOW, the first LOW-to-HIGH transition of WCLK writes data from the data inputs to the empty offset least significant bit (LSB) register. The second, third, and fourth LOW-to-HIGH transitions of WCLK store data in the empty offset most significant bit (MSB) register, full offset LSB register, and full offset MSB register, respectively, when $\overline{WEN2/LD}$ and $\overline{WEN1}$ are LOW. The fifth LOW-to-HIGH transition of WCLK while $\overline{WEN2/LD}$ and $\overline{WEN1}$ are LOW writes data to the empty LSB register again. Figure 3 shows the register sizes and default values for the various device types.

Figure 3. Offset Register Location and Default Values

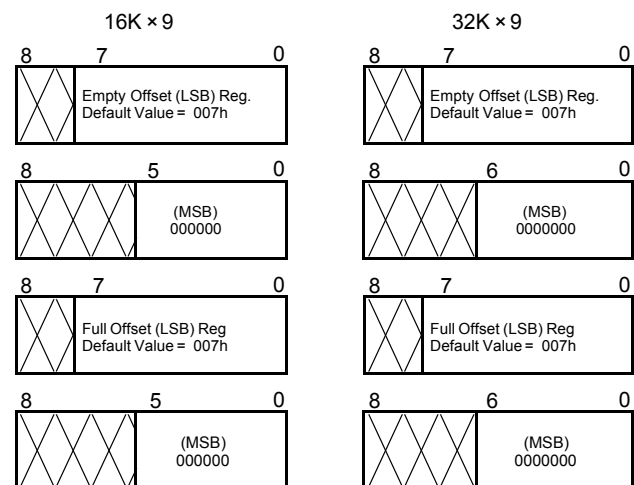





It is not necessary to write to all the offset registers at one time. A subset of the offset registers can be written, and then by bringing the WEN2/LD input HIGH, the FIFO is returned to normal read and write operation. The next time WEN2/LD is brought LOW, a write operation stores data in the next offset register in sequence.

The contents of the offset registers can be read to the data outputs when WEN2/LD is LOW and both REN1 and REN2 are LOW. LOW-to-HIGH transitions of RCLK read register contents to the data outputs. Writes and reads must not be performed simultaneously on the offset registers.

Programmable Flag (PAE, PAF) Operation

Whether the flag offset registers are programmed as described in Table 2 or the default values are used, the programmable almost-empty flag (PAE) (PAF) states are determined by their corresponding offset registers and the difference between the read and write pointers.

Table 2. Writing the Offset Registers

LD	WEN	WCLK ^[1]	Selection
0	0		Empty Offset (LSB) Empty Offset (MSB) Full Offset (LSB) Full Offset (MSB)
0	1		No Operation
1	0		Write Into FIFO
1	1		No Operation

The number formed by the empty offset least significant bit register and empty offset most significant bit register is referred to as *n* and determines the operation of PAE. PAF is synchronized to the LOW-to-HIGH transition of RCLK by one flip-flop and is LOW when the FIFO contains *n* or fewer unread words. PAE is set HIGH by the LOW-to-HIGH transition of RCLK when the FIFO contains (*n*+1) or greater unread words.

The number formed by the full offset least significant bit register and full offset most significant bit register is referred to as *m* and determines the operation of PAF. PAE is synchronized to the LOW-to-HIGH transition of WCLK by one flip-flop and is set LOW when the number of unread words in the FIFO is greater than or equal to CY7C4261 (16K-*m*) and CY7C4271 (32K-*m*). PAF is set HIGH by the LOW-to-HIGH transition of WCLK when the number of available memory locations is greater than *m*.

Table 3. Status Flags

Number of Words in FIFO		FF	PAF	PAE	EF
CY7C4261	CY7C4271				
0	0	H	H	L	L
1 to <i>n</i> ^[2]	1 to <i>n</i> ^[2]	H	H	L	H
(<i>n</i> + 1) to (16384 - (<i>m</i> + 1))	(<i>n</i> + 1) to (32768 - (<i>m</i> + 1))	H	H	H	H
(16384 - <i>m</i>) ^[3] to 16383	(32768 - <i>m</i>) ^[3] to 32767	H	L	H	H
16384	32768	L	L	H	H

Width Expansion Configuration

Word width may be increased by simply connecting the corresponding input controls signals of multiple devices. A composite flag must be created for each of the end-point status flags (EF and FF). The partial status flags (PAE and PAF) can be detected from any one device. Figure 4 on page 6 demonstrates a 18-bit word width by using two CY7C4261/71s. Any word width can be attained by adding additional CY7C4261/71s.

When the CY7C4261/71 is in a Width Expansion Configuration, the Read Enable (REN2) control input can be grounded (see Figure 4 on page 6). In this configuration, the Write Enable 2/Load (WEN2/LD) pin is set to LOW at Reset so that the pin operates as a control to load and read the programmable flag offsets.

Flag Operation

The CY7C4261/71 devices provide four flag pins to indicate the condition of the FIFO contents. Empty, Full, PAE, and PAF are synchronous.

Full Flag

The Full Flag (FF) goes LOW when the device is full. Write operations are inhibited whenever FF is LOW regardless of the state of WEN1 and WEN2/LD. FF is synchronized to WCLK, that is, it is exclusively updated by each rising edge of WCLK.

Empty Flag

The Empty Flag (EF) goes LOW when the device is empty. Read operations are inhibited whenever EF is LOW, regardless of the state of REN1 and REN2. EF is synchronized to RCLK, that is, it is exclusively updated by each rising edge of RCLK.

Notes

1. The same selection sequence applies to reading from the registers. REN1 and REN2 are enabled and a read is performed on the LOW-to-HIGH transition of RCLK.
2. *n* = Empty Offset (*n* = 7 default value).
3. *m* = Full Offset (*m* = 7 default value).

Figure 4. Block Diagram of 16K × 18/32K × 18 Deep Sync FIFO Memory Used in a Width Expansion Configuration

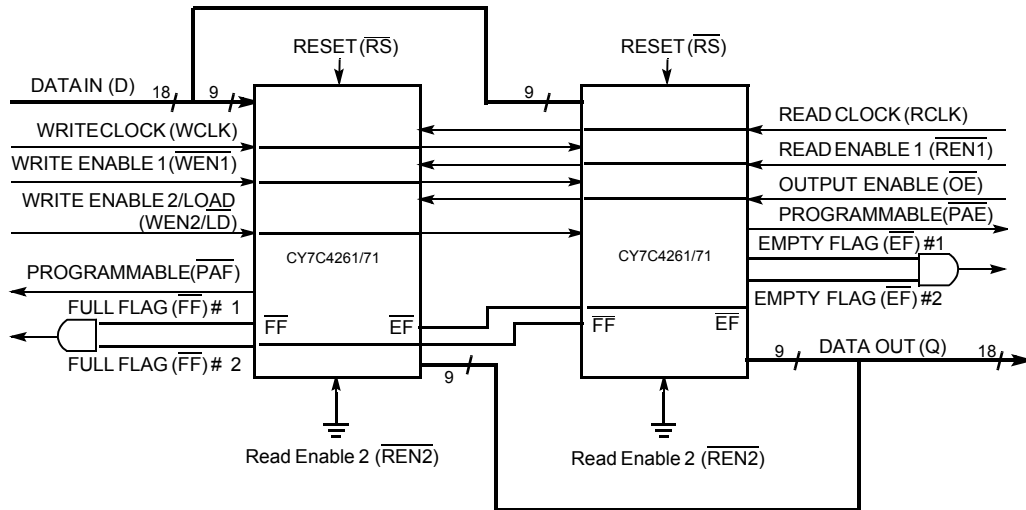

Maximum Ratings

Exceeding maximum ratings^[4] may impair the useful life of the device. These user guidelines are not tested.

- Storage Temperature -65°C to +150°C
- Ambient Temperature with Power Applied -55°C to +125°C
- Supply Voltage to Ground Potential -0.5V to +7.0V
- DC Voltage Applied to Outputs in High-Z State -0.5V to V_{CC} + 0.5V
- DC Input Voltage -0.5V to V_{CC} + 0.5V
- Output Current into Outputs (LOW) 20 mA

Static Discharge Voltage..... >2001V (per MIL-STD-883, Method 3015)

Latch-up Current..... >200 mA

Operating Range

Range	Ambient Temperature	V _{CC}
Commercial	0°C to +70°C	5V ± 10%
Industrial ^[5]	-40°C to +85°C	5V ± 10%
Military	-55°C to +125°C	5V ± 10%

Electrical Characteristics

Over the Operating Range ^[6]

Parameter	Description	Test Conditions	7C4261/71-10		7C4261/71-15		7C4261/71-25		7C4261/71-35		Unit
			Min	Max	Min	Max	Min	Max	Min	Max	
V _{OH}	Output HIGH Voltage	V _{CC} = Min, I _{OH} = -2.0 mA	2.4		2.4		2.4		2.4		V
V _{OL}	Output LOW Voltage	V _{CC} = Min, I _{OL} = 8.0 mA		0.4		0.4		0.4		0.4	V
V _{IH}	Input HIGH Voltage (Commercial/Industrial)		2.0	V _{CC}	2.0	V _{CC}	2.0	V _{CC}	2.0	V _{CC}	V
V _{IH}	Input HIGH Voltage (Military)		2.2	V _{CC}	2.2	V _{CC}	2.2	V _{CC}	2.2	V _{CC}	V
V _{IL}	Input LOW Voltage		-0.5	0.8	-0.5	0.8	-0.5	0.8	-0.5	0.8	V
I _{IX}	Input Leakage Current	V _{CC} = Max.	-10	+10	-10	+10	-10	+10	-10	+10	µA
I _{OZL} I _{OZH}	Output OFF, High Z Current	OE ≥ V _{IH} , V _{SS} < V _O < V _{CC}	-10	+10	-10	+10	-10	+10	-10	+10	µA
I _{CC1} ^[7]	Active Power Supply Current	Com'l		35		35		35		35	mA
		Ind/Mil		40		40		40		40	mA
I _{SB} ^[8]	Average Standby Current	Com'l		10		10		10		10	mA
		Ind/Mil		15		15		15		15	mA

Capacitance

Parameter ^[9]	Description	Test Conditions	Max	Unit
C _{IN}	Input Capacitance	T _A = 25°C, f = 1 MHz,	5	pF
C _{OUT}	Output Capacitance	V _{CC} = 5.0V		

Notes

4. The voltage on any input or IO pin cannot exceed the power pin during power up.
5. TA is the "instant on" case temperature.
6. See the last page of this specification for Group A subgroup testing information.
7. Input signals switch from 0V to 3V with a rise/fall time of less than 3 ns, clocks and clock enables switch at maximum frequency 20 MHz, while data inputs switch at 10 MHz. Outputs are unloaded. I_{CC1}(typical) = (20 mA + (freq - 20 MHz) * (0.7 mA/MHz)).
8. All inputs = V_{CC} - 0.2V, except WCLK and RCLK (which are switching at frequency = 20 MHz). All outputs are unloaded.
9. Tested initially and after any design or process changes that may affect these parameters.

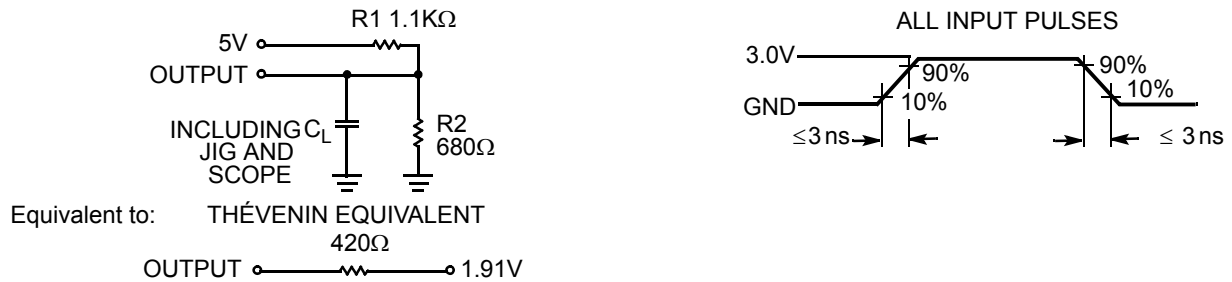
Figure 5. AC Test Loads and Waveforms ^[10, 11]

Switching Characteristics

Over the Operating Range

Parameter	Description	7C4261/71-10		7C4261/71-15		7C4261/71-25		7C4261/71-35		Unit
		Min	Max	Min	Max	Min	Max	Min	Max	
t_S	Clock Cycle Frequency		100		66.7		40		28.6	MHz
t_A	Data Access Time	2	8	2	10	2	15	2	20	ns
t_{CLK}	Clock Cycle Time	10		15		25		35		ns
t_{CLKH}	Clock HIGH Time	4.5		6		10		14		ns
t_{CLKL}	Clock LOW Time	4.5		6		10		14		ns
t_{DS}	Data Setup Time	3		4		6		7		ns
t_{DH}	Data Hold Time	0.5		1		1		2		ns
t_{ENS}	Enable Setup Time	3		4		6		7		ns
t_{ENH}	Enable Hold Time	0.5		1		1		2		ns
t_{RS}	Reset Pulse Width ^[12]	10		15		25		35		ns
t_{RSS}	Reset Setup Time	8		10		15		20		ns
t_{RSR}	Reset Recovery Time	8		10		15		20		ns
t_{RSF}	Reset to Flag and Output Time		10		15		25		35	ns
t_{OLZ}	Output Enable to Output in Low Z ^[13]	0		0		0		0		ns
t_{OE}	Output Enable to Output Valid	3	7	3	8	3	12	3	15	ns
t_{OHZ}	Output Enable to Output in High Z ^[13]	3	7	3	8	3	12	3	15	ns
t_{WFF}	Write Clock to Full Flag		8		10		15		20	ns
t_{REF}	Read Clock to Empty Flag		8		10		15		20	ns
t_{PAF}	Clock to Programmable Almost Full Flag		8		10		15		20	ns
t_{PAE}	Clock to Programmable Almost Full Flag		8		10		15		20	ns
t_{SKEW1}	Skew Time between Read Clock and Write Clock for Empty Flag and Full Flag	5		6		10		12		ns
t_{SKEW2}	Skew Time between Read Clock and Write Clock for Almost Empty Flag and Almost Full Flag	10		15		18		20		ns

Notes

10. $5C_L = 30$ pF for all AC parameters except for t_{OHZ} .
11. $5C_L = 5$ pF for t_{OHZ} .
12. Pulse widths less than minimum values are not allowed.
13. Values guaranteed by design, not currently tested.

Switching Waveforms

Figure 6. Write Cycle Timing

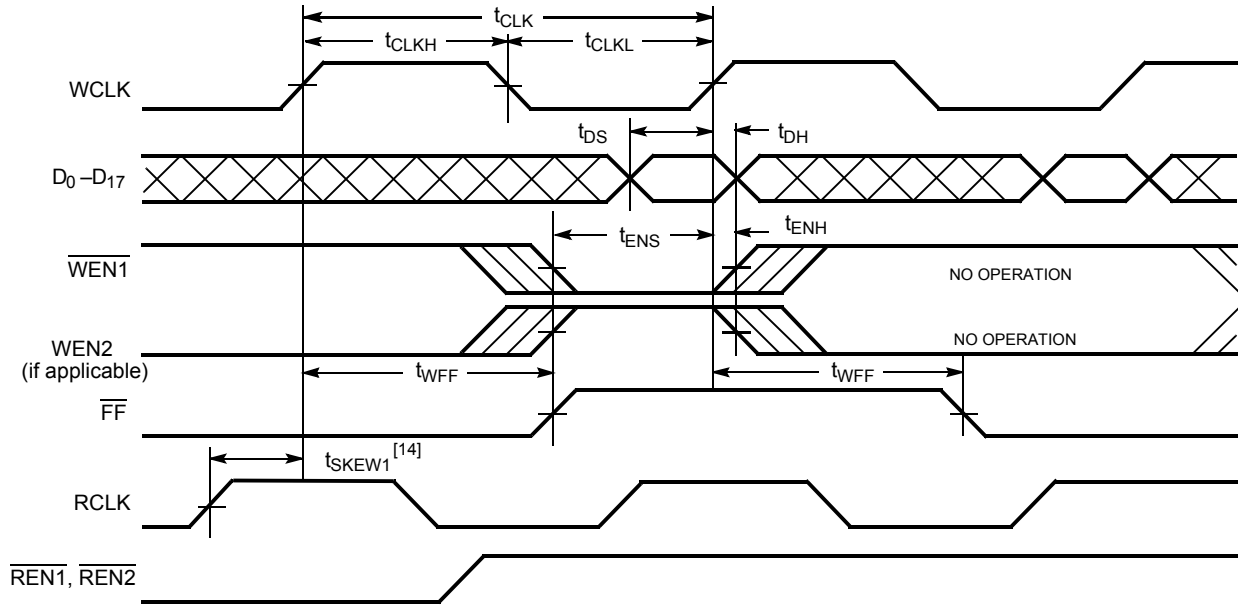
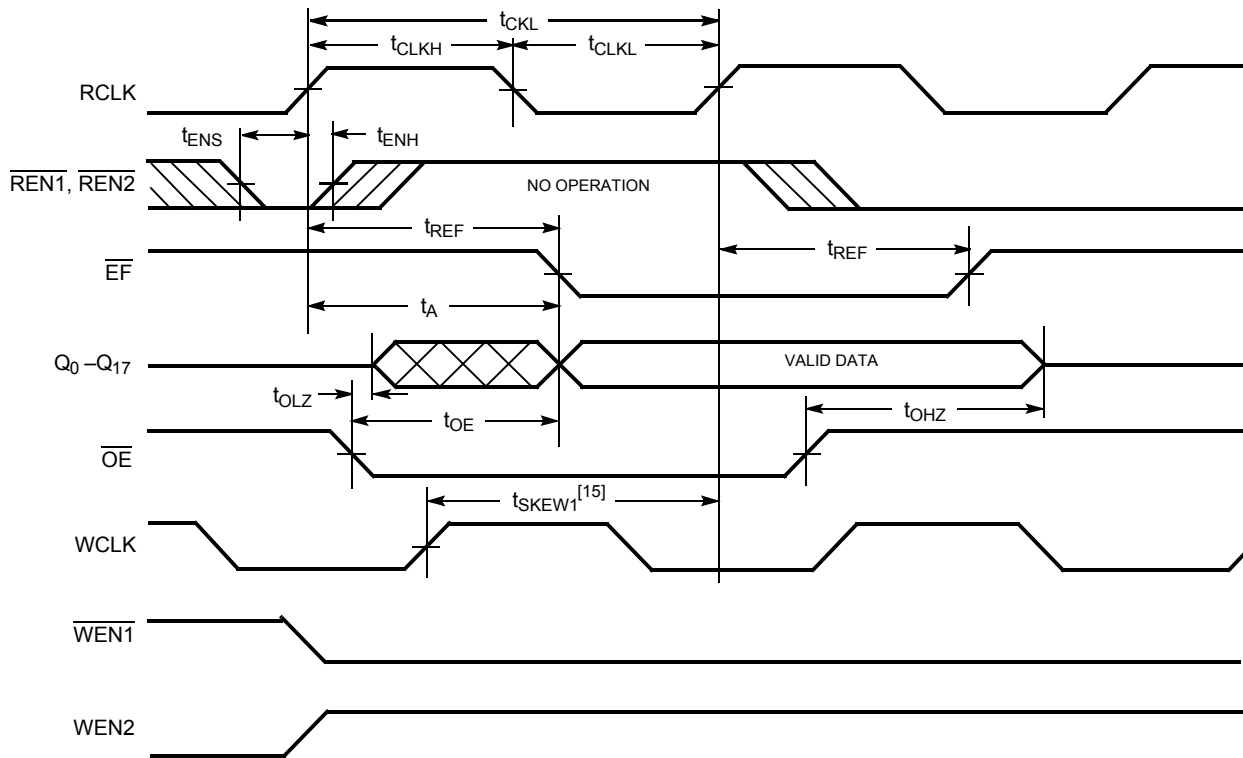

Figure 7. Read Cycle Timing



Notes

- 14. t_{SKEW1} is the minimum time between a rising RCLK edge and a rising WCLK edge to guarantee that \overline{FF} goes HIGH during the current clock cycle. If the time between the rising edge of RCLK and the rising edge of WCLK is less than t_{SKEW1} , then \overline{FF} may not change state until the next WCLK rising edge.
- 15. t_{SKEW1} is the minimum time between a rising WCLK edge and a rising RCLK edge to guarantee that \overline{EF} goes HIGH during the current clock cycle. If the time between the rising edge of WCLK and the rising edge of RCLK is less than t_{SKEW2} , then \overline{EF} may not change state until the next RCLK rising edge.

Switching Waveforms (continued)

Figure 8. Reset Timing [16]

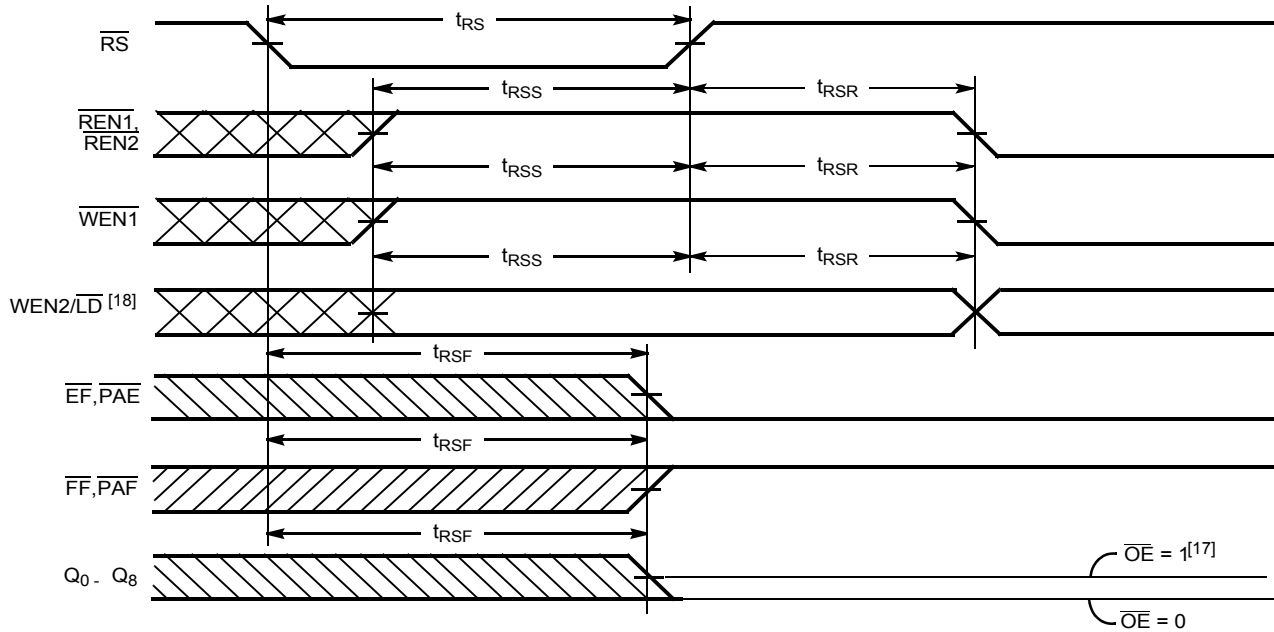
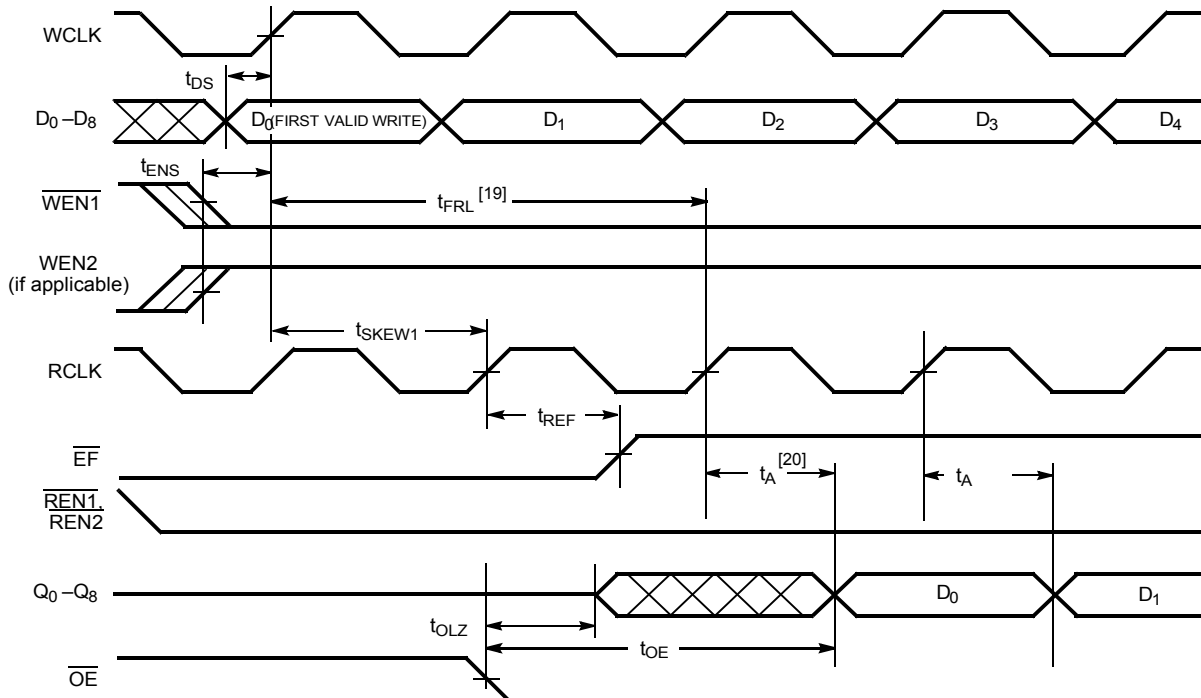

Figure 9. First Data Word Latency after Reset with Read and Write



Notes

16. The clocks (RCLK, WCLK) can be free running during reset.
17. After reset, the outputs are LOW if $\overline{OE} = 0$ and three-state if $\overline{OE} = 1$.
18. Holding $\overline{WEN2/LD}$ HIGH during reset makes the pin act as a second enable pin. Holding $\overline{WEN2/LD}$ LOW during reset makes the pin act as a load enable for the programmable flag offset registers.
19. When $t_{SKEW1} \geq$ minimum specification, t_{FRL} (maximum) = $t_{CLK} + t_{SKEW2}$. When $t_{SKEW1} <$ minimum specification, t_{FRL} (maximum) = either $2 * t_{CLK} + t_{SKEW1}$ or $t_{CLK} + t_{SKEW1}$. The Latency Timing applies only at the Empty Boundary ($\overline{EF} = \text{LOW}$).
20. The first word is available the cycle after \overline{EF} goes HIGH, always.

Switching Waveforms (continued)

Figure 10. Empty Flag Timing

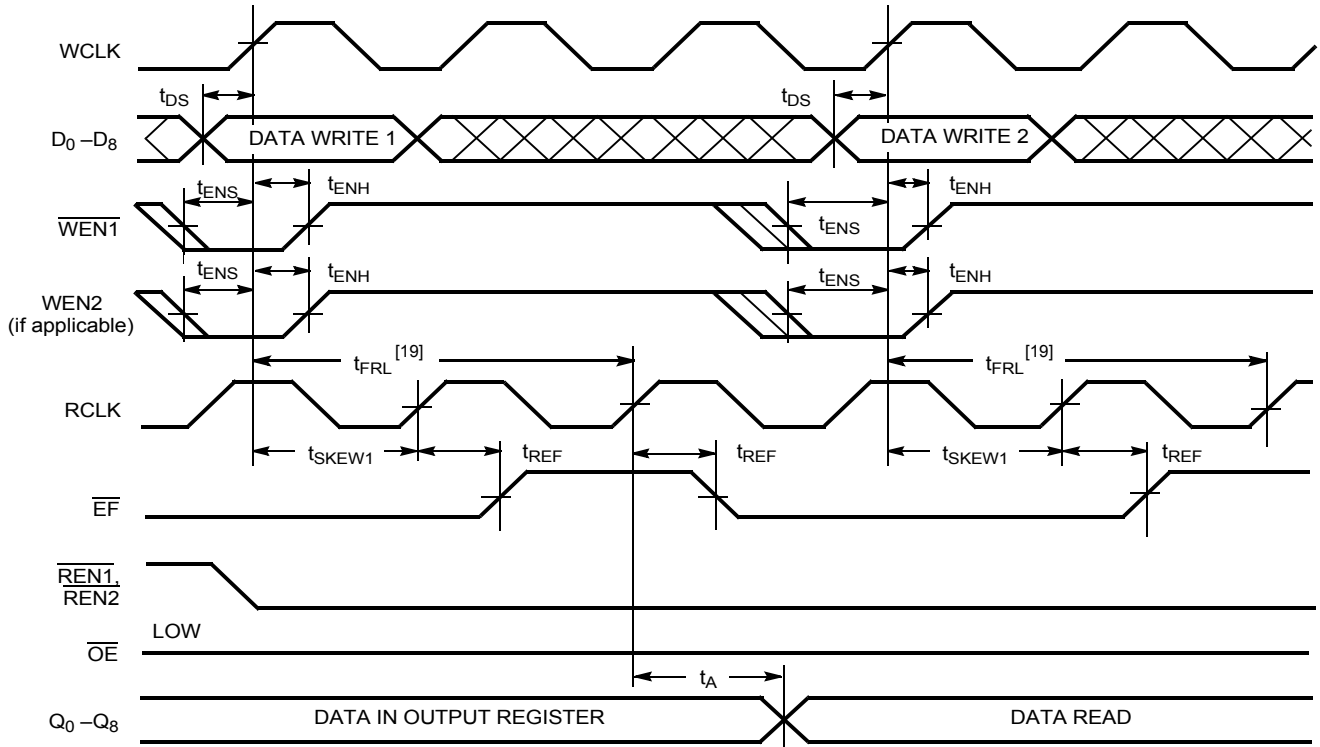
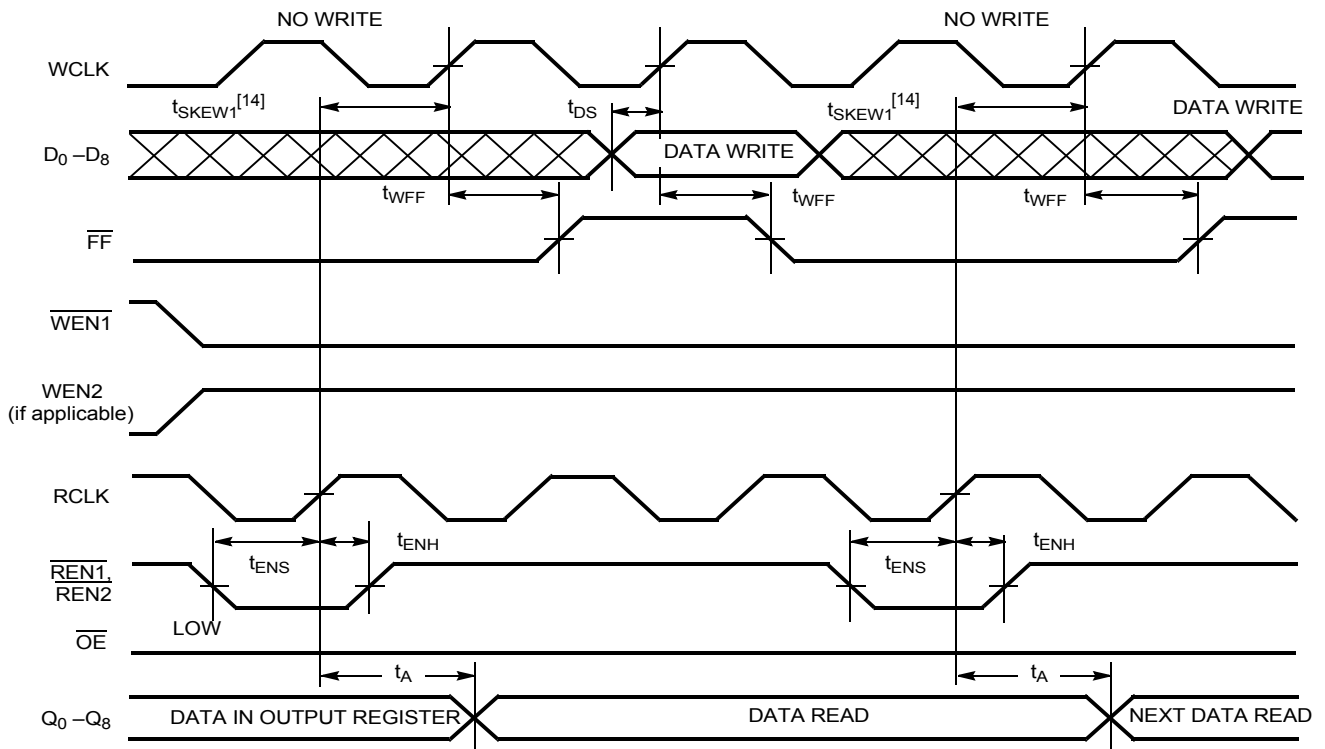

Figure 11. Full Flag Timing



Switching Waveforms (continued)

Figure 12. Programmable Almost Empty Flag Timing

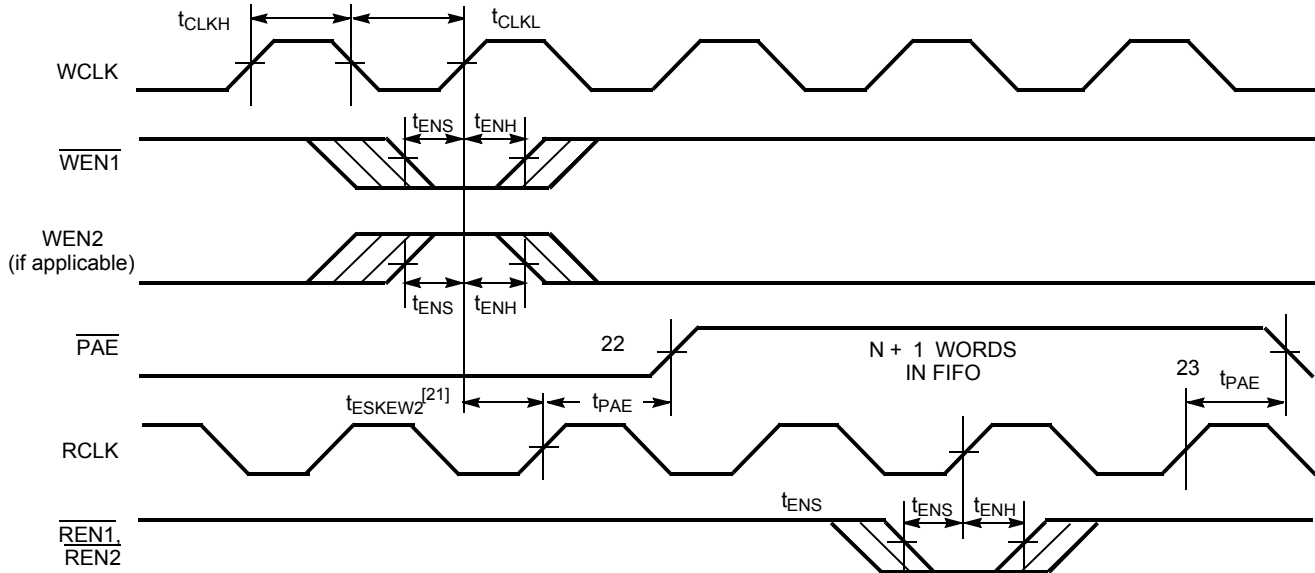
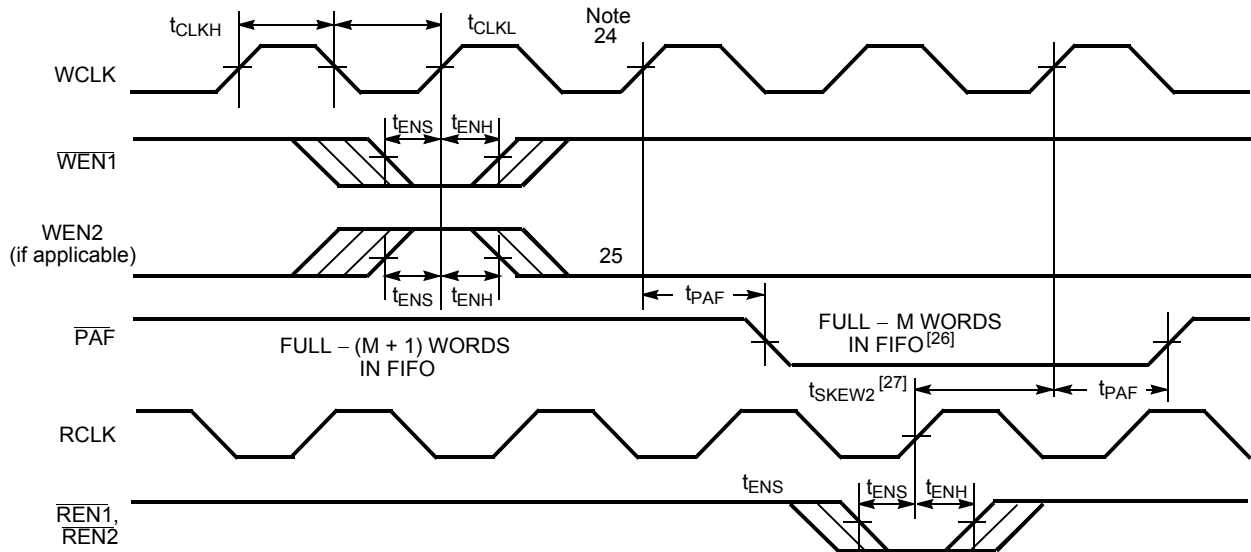

Figure 13. Programmable Almost Full Flag Timing



Notes

- 21. t_{SKEW2} is the minimum time between a rising WCLK and a rising RCLK edge for \overline{PAE} to change state during that clock cycle. If the time between the edge of WCLK and the rising RCLK is less than t_{SKEW2} , then PAE may not change state until the next RCLK.
- 22. PAE offset = n.
- 23. If a read is performed on this rising edge of the read clock, there are Empty + (n-1) words in the FIFO when \overline{PAE} goes LOW.
- 24. If a write is performed on this rising edge of the write clock, there are Full - (m-1) words of the FIFO when \overline{PAF} goes LOW.
- 25. PAF offset = m.
- 26. 16,384 - m words for CY7C4261, 32,768 - m words for CY7C4271.
- 27. t_{SKEW2} is the minimum time between a rising RCLK edge and a rising WCLK edge for \overline{PAF} to change during that clock cycle. If the time between the rising edge of RCLK and the rising edge of WCLK is less than t_{SKEW2} , then \overline{PAF} may not change state until the next WCLK.

Switching Waveforms (continued)

Figure 14. Write Programmable Registers

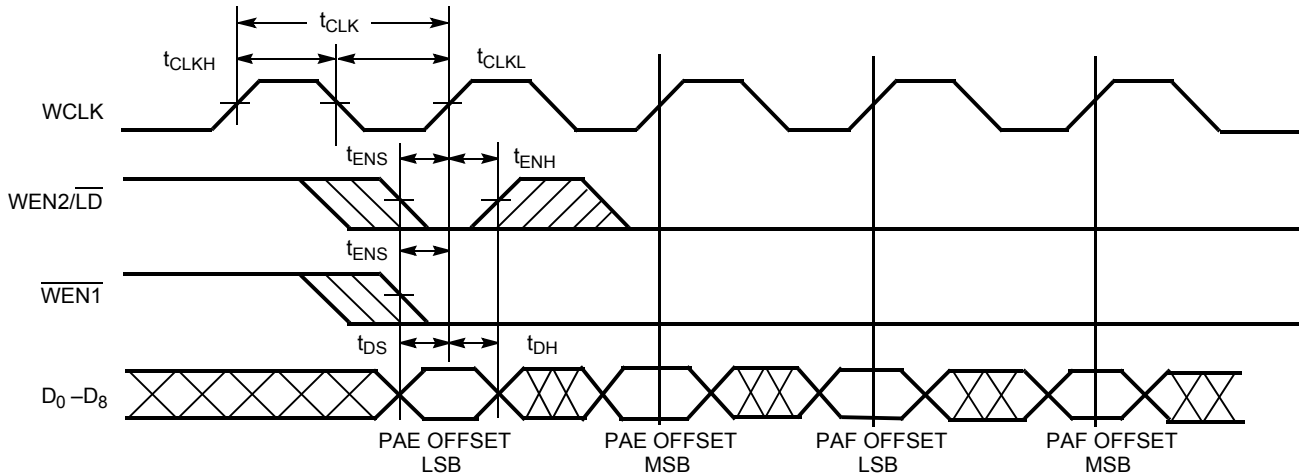

Figure 15. Read Programmable Registers

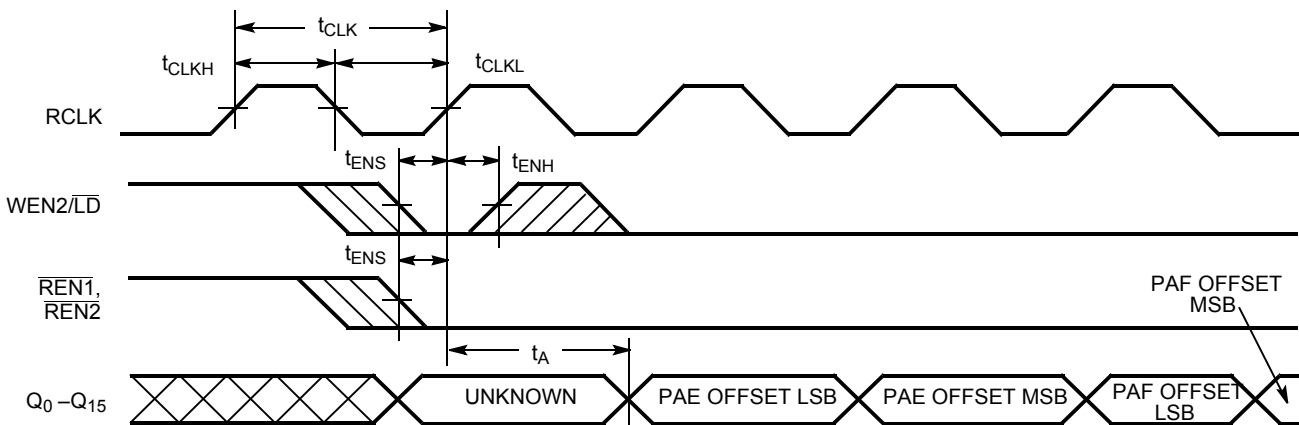
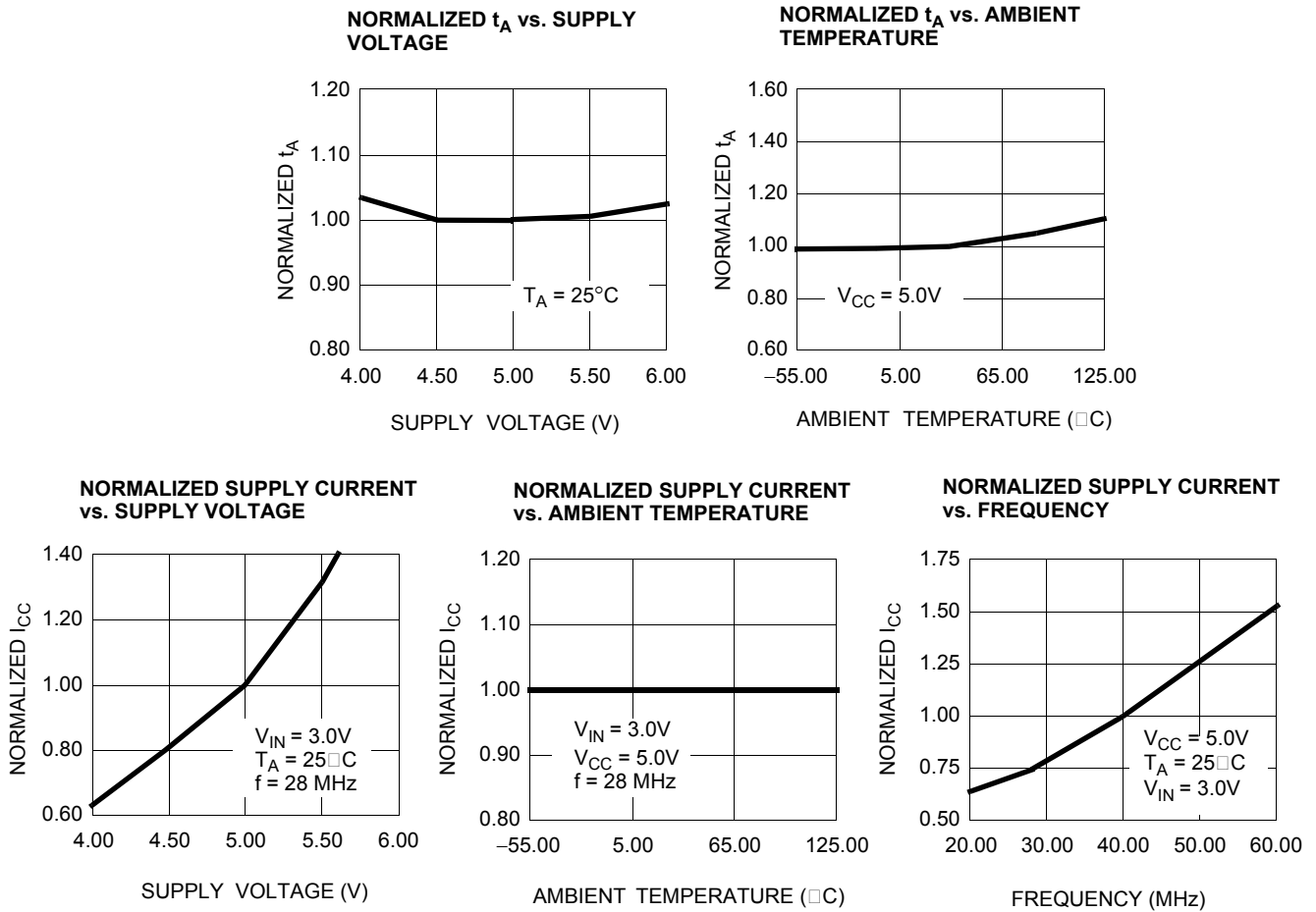

Figure 16. Typical AC and DC Characteristics



Ordering Information

16 K × 9 Deep Sync FIFO

Speed (ns)	Ordering Code	Package Diagram	Package Type	Operating Range
10	CY7C4261-10JXI	51-85002	32-pin Plastic Leaded Chip Carrier (Pb-free)	Industrial
15	CY7C4261-15JXC			Commercial

32 K × 9 Deep Sync FIFO

Speed (ns)	Ordering Code	Package Diagram	Package Type	Operating Range
15	CY7C4271-15AXC	51-85063	32-pin Thin Quad Flat Pack (7 x 7 x 1.0 mm) (Pb-free)	

Ordering Code Definitions

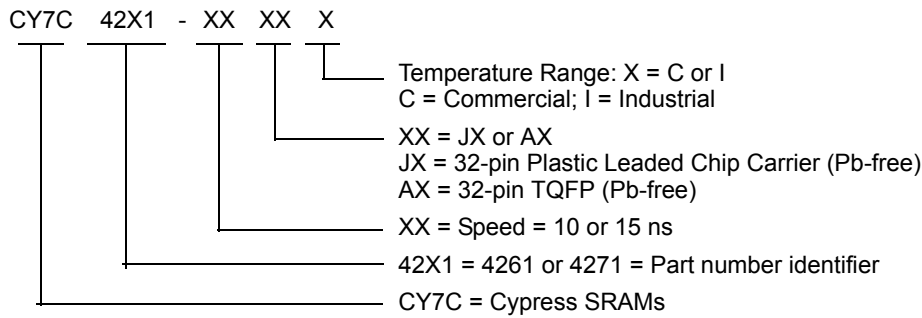

Table 4. DC Characteristics

Parameters	Subgroups
V _{OH}	1, 2, 3
V _{OL}	1, 2, 3
V _{IH}	1, 2, 3
V _{IL Max.}	1, 2, 3
I _{Ix}	1, 2, 3
I _{CC}	1, 2, 3
I _{CC1}	1, 2, 3
I _{SB1}	1, 2, 3
I _{SB2}	1, 2, 3
I _{OS}	1, 2, 3

Table 5. Switching Characteristics

Parameters	Subgroups
t _{RC}	9, 10, 11
t _A	9, 10, 11
t _{RR}	9, 10, 11
t _{PR}	9, 10, 11
t _{DVR}	9, 10, 11
t _{WC}	9, 10, 11
t _{PW}	9, 10, 11
t _{WR}	9, 10, 11
t _{SD}	9, 10, 11
t _{HD}	9, 10, 11
t _{MRSC}	9, 10, 11
t _{PMR}	9, 10, 11
t _{RMR}	9, 10, 11
t _{RPW}	9, 10, 11
t _{WPW}	9, 10, 11
t _{RTC}	9, 10, 11
t _{PRT}	9, 10, 11
t _{RTR}	9, 10, 11
t _{EFL}	9, 10, 11
t _{HFH}	9, 10, 11
t _{FFH}	9, 10, 11
t _{REF}	9, 10, 11
t _{RFF}	9, 10, 11
t _{WEF}	9, 10, 11
t _{WFF}	9, 10, 11
t _{WHF}	9, 10, 11
t _{RHF}	9, 10, 11
t _{RAE}	9, 10, 11
t _{RPE}	9, 10, 11
t _{WAF}	9, 10, 11
t _{WPF}	9, 10, 11
t _{XOL}	9, 10, 11
t _{XOH}	9, 10, 11

Package Diagrams

Figure 17. 32-Pin Thin Plastic Quad Flatpack (7 × 7 × 1.0 mm)

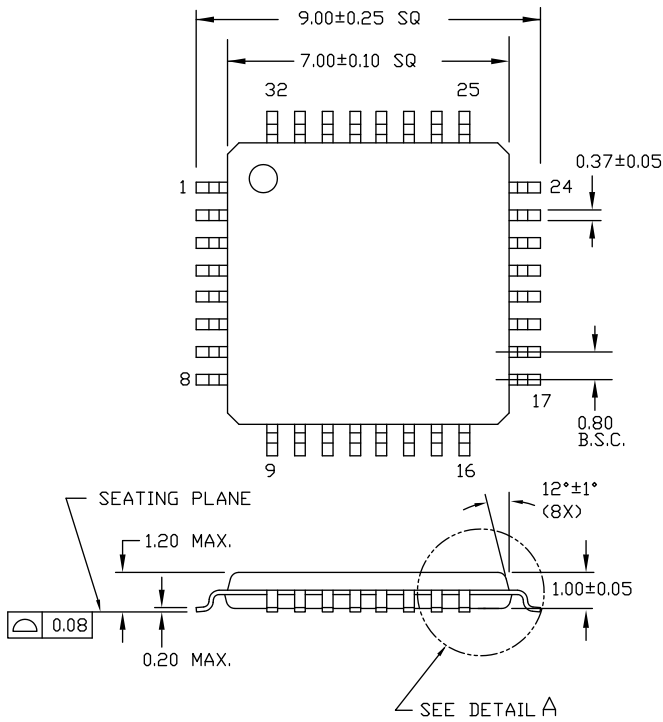

DIMENSIONS ARE IN MILLIMETERS

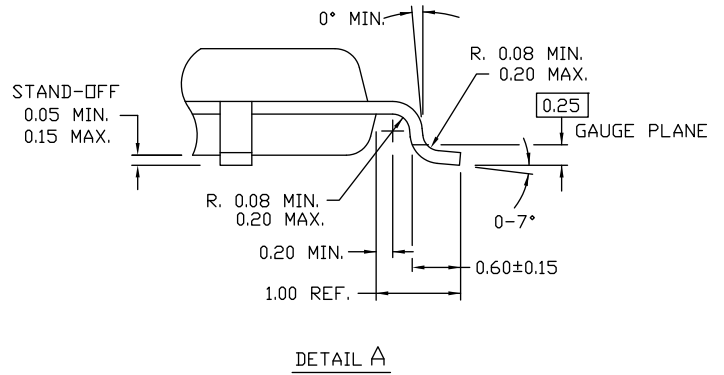

51-85063 *C

Figure 18. 32-Pin Plastic Leaded Chip Carrier

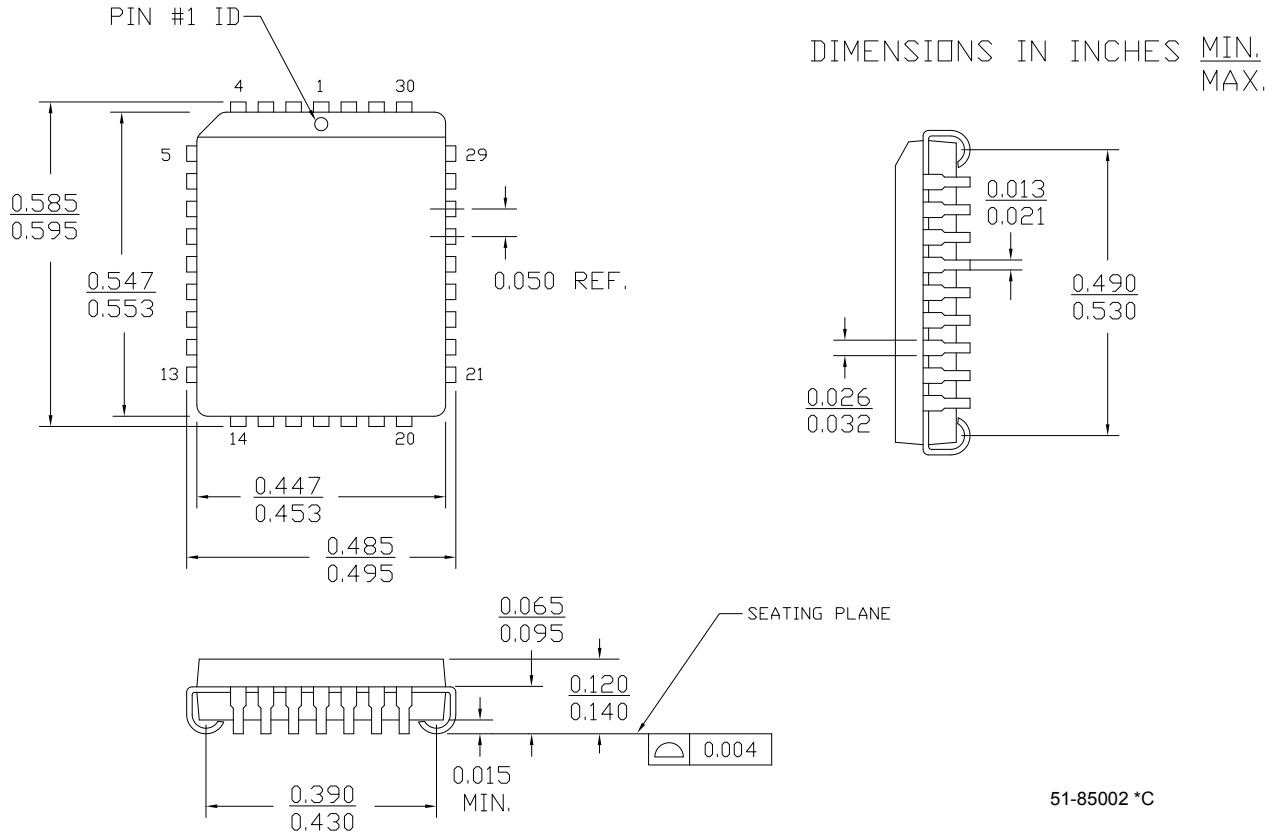
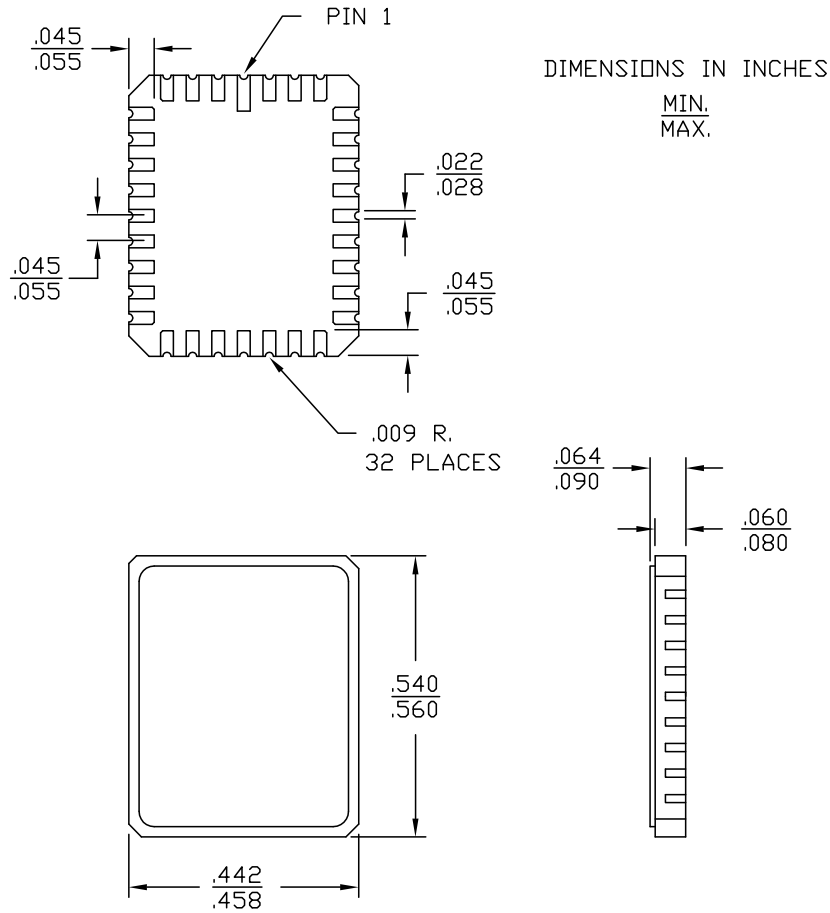

Figure 19. 32-Pin Rectangular Leadless Chip Carrier



51-80068 *A

Document History Page

Document Title: CY7C4261/CY7C4271 16K/32K x 9 Deep Sync FIFOs				
Document Number: 38-06015				
REV.	ECN	Orig. of Change	Submission Date	Description of Change
**	106476	SZV	09/10/01	Changed from Spec number: 38-00658 to 38-06015
*A	122267	RBI	12/26/02	Added power up requirements Maximum Ratings Information
*B	127853	FSG	08/22/03	Switching Waveforms section: fixed misplaced footnote in t_A in "First Data Word Latency after Reset with Read and Write" drawing Switching Waveforms section: changed t_{SKEW2} to t_{SKEW1} (typo) in "Empty Flag Timing" drawing
*C	393437	ESH	See ECN	Added Pb-Free Logo to top of front page Added CY7C4261-10JXI, CY7C4261-15JXC to ordering information
*D	2556036	VKN/AESA	08/22/2008	Updated ordering information and data sheet template. Removed Pb-Free Logo.
*E	2896039	RAME	03/19/2010	Updated package diagrams Removed inactive parts from Ordering information table Updated links in Sales, Solutions and Legal Information
*F	3055213	ADMU	10/13/2010	Removed CY7C4271-15AC from Ordering Information and added Ordering Code Definitions .

Sales, Solutions, and Legal Information

Worldwide Sales and Design Support

Cypress maintains a worldwide network of offices, solution centers, manufacturer's representatives, and distributors. To find the office closest to you, visit us at [Cypress Locations](#).

Products

Automotive	cypress.com/go/automotive
Clocks & Buffers	cypress.com/go/clocks
Interface	cypress.com/go/interface
Lighting & Power Control	cypress.com/go/powerpsoc cypress.com/go/plc
Memory	cypress.com/go/memory
Optical & Image Sensing	cypress.com/go/image
PSoC	cypress.com/go/psoc
Touch Sensing	cypress.com/go/touch
USB Controllers	cypress.com/go/USB
Wireless/RF	cypress.com/go/wireless

PSoC Solutions

psoc.cypress.com/solutions
PSoC 1 | PSoC 3 | PSoC 5

© Cypress Semiconductor Corporation, 2001-2010. The information contained herein is subject to change without notice. Cypress Semiconductor Corporation assumes no responsibility for the use of any circuitry other than circuitry embodied in a Cypress product. Nor does it convey or imply any license under patent or other rights. Cypress products are not warranted nor intended to be used for medical, life support, life saving, critical control or safety applications, unless pursuant to an express written agreement with Cypress. Furthermore, Cypress does not authorize its products for use as critical components in life-support systems where a malfunction or failure may reasonably be expected to result in significant injury to the user. The inclusion of Cypress products in life-support systems application implies that the manufacturer assumes all risk of such use and in doing so indemnifies Cypress against all charges.

Any Source Code (software and/or firmware) is owned by Cypress Semiconductor Corporation (Cypress) and is protected by and subject to worldwide patent protection (United States and foreign), United States copyright laws and international treaty provisions. Cypress hereby grants to licensee a personal, non-exclusive, non-transferable license to copy, use, modify, create derivative works of, and compile the Cypress Source Code and derivative works for the sole purpose of creating custom software and or firmware in support of licensee product to be used only in conjunction with a Cypress integrated circuit as specified in the applicable agreement. Any reproduction, modification, translation, compilation, or representation of this Source Code except as specified above is prohibited without the express written permission of Cypress.

Disclaimer: CYPRESS MAKES NO WARRANTY OF ANY KIND, EXPRESS OR IMPLIED, WITH REGARD TO THIS MATERIAL, INCLUDING, BUT NOT LIMITED TO, THE IMPLIED WARRANTIES OF MERCHANTABILITY AND FITNESS FOR A PARTICULAR PURPOSE. Cypress reserves the right to make changes without further notice to the materials described herein. Cypress does not assume any liability arising out of the application or use of any product or circuit described herein. Cypress does not authorize its products for use as critical components in life-support systems where a malfunction or failure may reasonably be expected to result in significant injury to the user. The inclusion of Cypress' product in a life-support systems application implies that the manufacturer assumes all risk of such use and in doing so indemnifies Cypress against all charges.

Use may be limited by and subject to the applicable Cypress software license agreement.