

Voltage Step-up Coils

Series: **Chip**
Type: **3KN**



ELT3KN

High inductance Voltage Step-up coil chip series for piezoelectric buzzers and DC-DC circuitry of EL panels

■ Features

- Small and thin
- High inductance

■ Recommended Applications

- Watches, Toys, Cameras, Electronic thermometers
- Pagers, PHS, wireless telephones

■ Explanation of Part Numbers

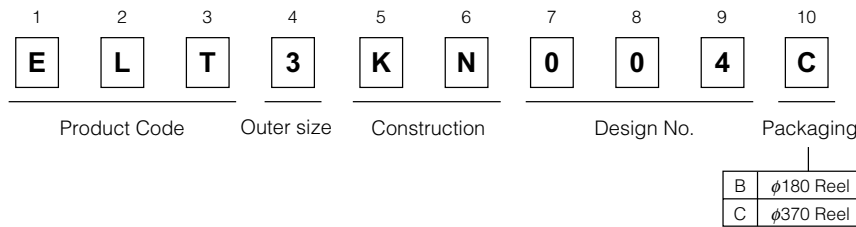

■ Standard Packing Quantity

- 1000 or 5000 pcs./Reel

■ Soldering Conditions

Please see Page 169

■ Dimensions in mm (not to scale)

- Type 3KN

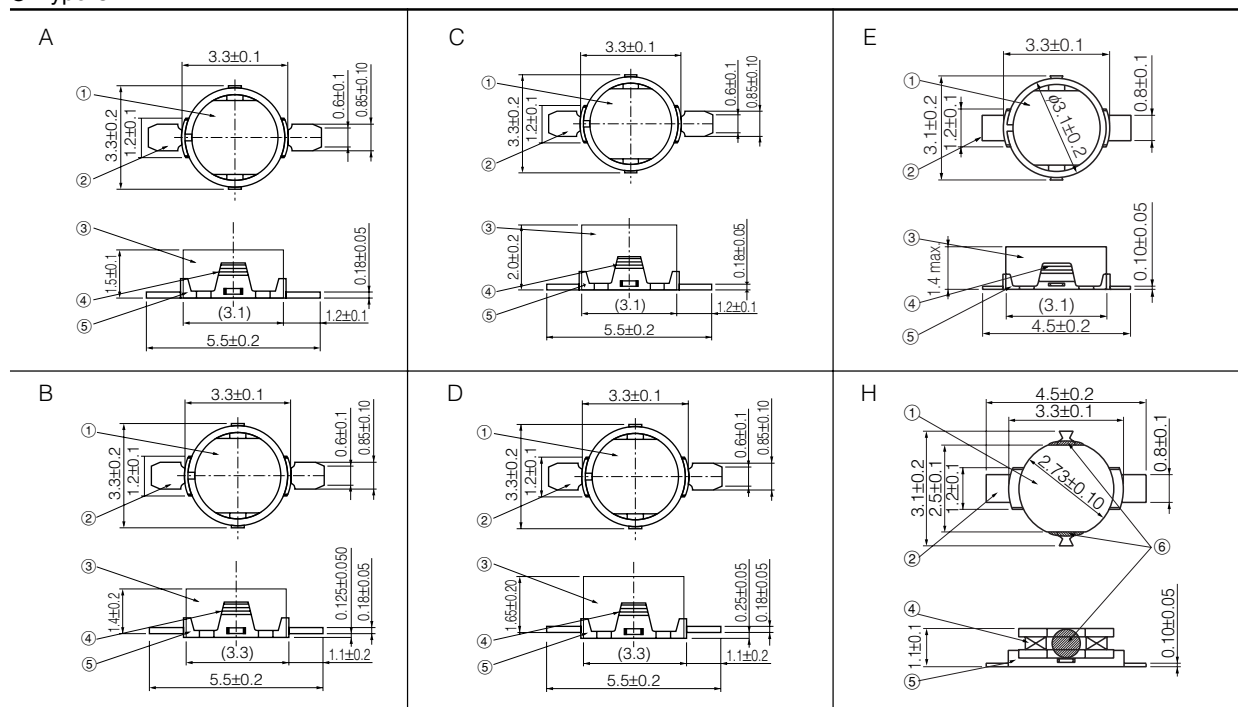

Part Name: ① Core ② Terminal ③ Ring ④ Coil ⑤ Terminal board ⑥ Adhesive

Design and specifications are each subject to change without notice. Ask factory for the current technical specifications before purchase and/or use. Should a safety concern arise regarding this product, please be sure to contact us immediately.

00 Sep. 2010

■ Standard Parts

Part No.	Inductance		R. D. C		I.D.C (mA) max.	Dimensions	Magnetic Composition	
	(mH)	Tolerance(%)	(Ω)	Tolerance(%)				
ELT3KN004□	14.00	±40	125	±10	1.7	A	Permalloy ring	
ELT3KN007□	20.00		170		1.4			
ELT3KN113□	1.00	±10	34	±15	25.0		Brass ring	
ELT3KN126□	1.50		49		29.0			
ELT3KN142□	0.82		24		30.0			
ELT3KN019□	14.00	±40	125	±10	1.7	B	Permalloy ring	
ELT3KN109□	3.80	±10	115	±20	15.0		Brass ring	
ELT3KN114□	2.50		83	±15	15.0			
ELT3KN014□	30.00	±40	150	±10	1.9	C	Permalloy ring	
ELT3KN018□	35.00		235		1.9			
ELT3KN028□	50.00	±35	250	±15	1.4			
ELT3KN032□	25.00	±40	185		10.0			
ELT3KN101□	10.00	±10	285	±10	1.4		Brass ring	
ELT3KN104□	1.00		35	±15	30.0			
ELT3KN118□	2.50		64		20.0			
ELT3KN122□	2.00		44		20.0			
ELT3KN127□	0.47		14		50.0			
ELT3KN128□	0.56		15		45.0			
ELT3KN129□	0.68		17		34.0			
ELT3KN130□	2.30		51		23.0			
ELT3KN020□	30.00		±30		150			2.5
ELT3KN111□	7.50	±10	177			10.0	Brass ring	
ELT3KN125□	4.00		85	15.0				
ELT3KN041□	14.00	±40	125	±10	1.7	E	Permalloy ring	
ELT3KN042□	20.00		175		1.4			
ELT3KN043□	12.00		117		1.7			
ELT3KN139□	0.68	±10	19	±15	40.0		Brass ring	
ELT3KN140□	0.82		22		30.0			
ELT3KN135□	1.10		32		30.0			
ELT3KN136□	2.00		55	20.0				
ELT3KN137□	4.00		117	±10	15.0			
ELT3KN149□	0.33		11	±15	60.0			
ELT3KN151□	0.56		17		50.0			
ELT3KN152□	0.47		14		50.0			
ELT3KN155□	1.10		38		25.0	H		Ring less
ELT3KN162□	4.00	117	±10	15.0	E	Brass ring		
ELT3KN163□	1.10	32	±15	30.0				

“□” shows the packaging specifications.

■ Packaging Methods

● Standard Packing Quantity

Packaging	ELT3KN	Kind of Taping
B	1000 pcs.	Embossed Carrier Taping
C	5000 pcs.	

● Reel Dimensions in mm (not to scale)

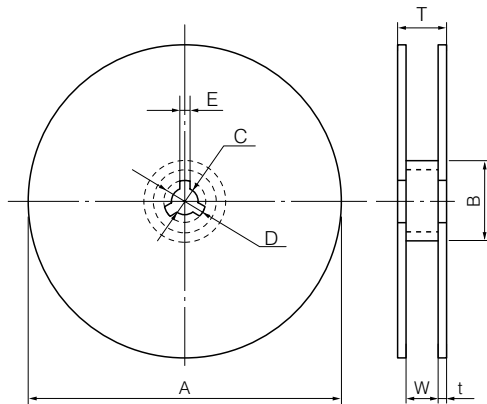

Packaging	A	B	C	D	E	W	t	T
B	180	60	13	21	2	13	1.1	15.2
C	370	60	13	21	2	14	2.0	18

■ Applied Diagram Examples

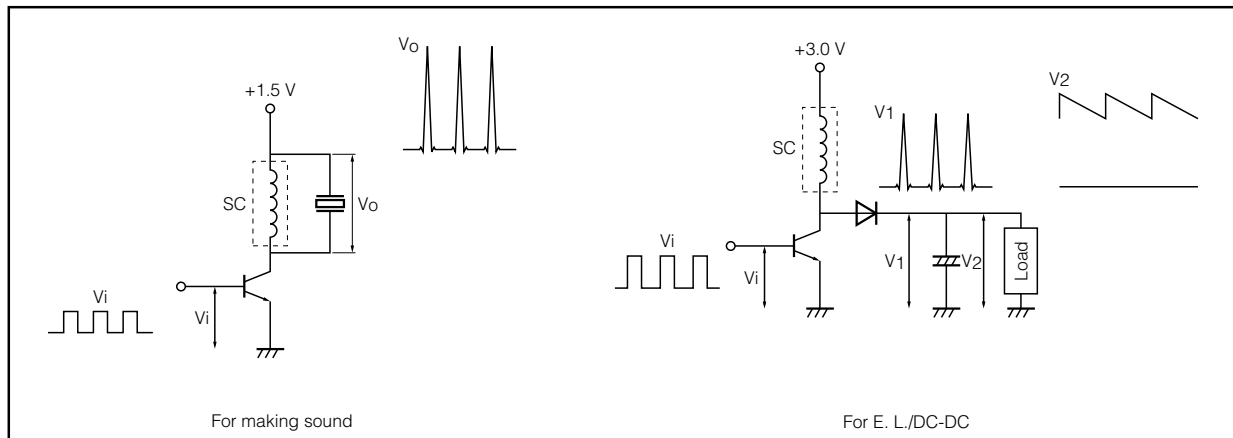

● Embossed Carrier Tape Dimensions in mm (not to scale)

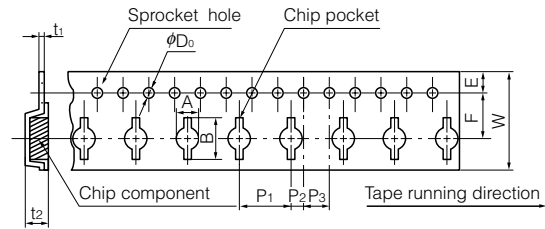

Type	A	B	W	F	E	P ₁
ELT3KN	3.7	6.4	12.0	5.5	1.75	8.0

Type	P ₂	P ₃	φD ₀	t ₁	t ₂
ELT3KN	2.0	4.0	1.5	0.3	2.6

● Leader Part, Vacant Position

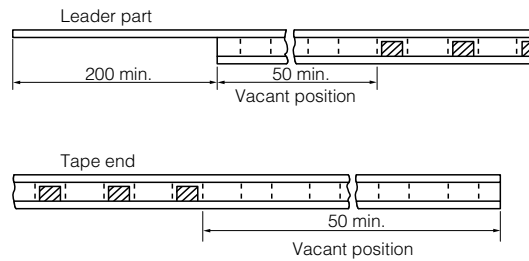

Soldering Conditions

■ Reflow soldering conditions

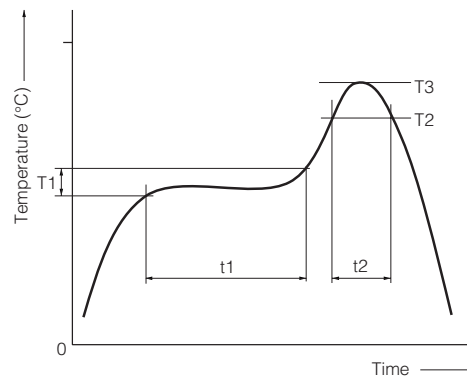

● Pb free solder recommended temperature profile

Products Item	Preheat		Soldering		Peak Temperature		Time of Reflow
	T1 [°C]	t1 [s]	T2 [°C]	t2 [s]	T3	T3 Limit	
SMD Choke Coils	150 to 170	60 to 120	230 °C	30 max.	245 °C, 10 s	260 °C, 10 s	2 times max.

● Pb free solder recommended temperature profile

Products Item	Preheat		Soldering		Peak Temperature		Time of Reflow
	T1 [°C]	t1 [s]	T2 [°C]	t2 [s]	T3	T3 Limit	
Voltage Step-up Coils	150 to 170	60 to 120	230 °C	30 max.	245 °C, 10 s	260 °C, 10 s	2 times max.

⚠ Safety Precautions (Common precautions for Voltage Step-up Coils)

- When using our products, no matter what sort of equipment they might be used for, be sure to make a written agreement on the specifications with us in advance. The design and specifications in this catalog are subject to change without prior notice.
- Do not use the products beyond the specifications described in this catalog.
- This catalog explains the quality and performance of the products as individual components. Before use, check and evaluate their operations when installed in your products.
- Install the following systems for a failsafe design to ensure safety if these products are to be used in equipment where a defect in these products may cause the loss of human life or other significant damage, such as damage to vehicles (automobile, train, vessel), traffic lights, medical equipment, aerospace equipment, electric heating appliances, combustion/gas equipment, rotating equipment, and disaster/crime prevention equipment.
- * Systems equipped with a protection circuit and a protection device
- * Systems equipped with a redundant circuit or other system to prevent an unsafe status in the event of a single fault

⚠ Precautions for use

1. Operation range and environments

- ① These products are designed and manufactured for general and standard use in general electronic equipment (e.g. AV equipment, home electric appliances, office equipment, information and communication equipment)
- ② These products are not intended for use in the following special conditions. Before using the products, carefully check the effects on their quality and performance, and determine whether or not they can be used.
 - In liquid, such as water, oil, chemicals, or organic solvent
 - In direct sunlight, outdoors, or in dust
 - In salty air or air with a high concentration of corrosive gas, such as Cl₂, H₂S, NH₃, SO₂, or NO₂
 - In an environment where these products cause dew condensation

2. Handling

- ① Do not bring magnets or magnetized materials close to the product. The influence of their magnetic field can change the inductance value.
- ② Do not apply strong mechanical shocks by either dropping or collision with other parts.
Excessive shock can damage the part.

3. Resoldering with a soldering iron

- ① Resoldering should be done within 3 seconds by soldering iron, the temperature with 350 °C or less and should be cooling down after ward. Both side of terminals shall be fixed closely to PWB. And terminals shall not be pressed in heating.

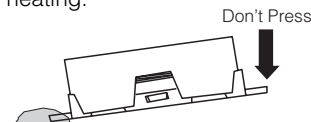

- ② The wiring tab shall not be held by sharp-edged tool.

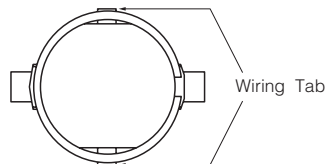

- ③ Iron shall not be put to the component itself.

4. Mounting side

- ① External force must be less than 4.9N while mounting.
- ② The wiring tab is expose the terminal, so please be careful when you design PWB pattern of coil circumference.

5. Cleaning

If you clean the inductor, please use own your ultrasonic cleaning to check specified conditions.

6. Storage conditions

Normal temperature (-5 to 35 °C), normal humidity (85 % RH max.), shall not be exposed to direct sunlight and harmful gases and care should be taken so as not to cause dew.

<Package markings>

Package markings include the product number, quantity, and country of origin.

In principle, the country of origin should be indicated in English.