

# S71PL-J Based MCPs



*Data Sheet (Retired Product)*

---

This product has been retired and is not recommended for new designs. For new designs, S71GL-A or S71GL-N supersedes S71PL-J. Please contact your local SpanSion sales office to determine the appropriate migration device, specifications, and ordering information. Availability of this document is retained for reference and historical purposes only.



# S71PL-J Based MCPs

## Stacked Multi-Chip Product (MCP) Flash Memory and RAM

256M/128/64/32 Megabit (16/8/4/2M x 16-bit) CMOS 3.0 Volt-only Simultaneous Operation Page Mode Flash Memory and 64/32/16/8/4 Megabit (4M/2M/1M/512K/256K x 16-bit) Static RAM/pSRAM



### Data Sheet

**Note:** This product has been retired and is not recommended for new designs. For new designs, S71GL-A or S71GL-N supersedes S71PL-J. Please contact your local Spansion sales office to determine the appropriate migration device, specifications, and ordering information. Availability of this document is retained for reference and historical purposes only.

## Features

- Power supply voltage of 2.7 V to 3.1 V
- High performance
  - 65 ns (65 ns Flash, 70 ns pSRAM)
- Packages
  - 7 x 9 x 1.2 mm 56 ball FBGA
  - 8 x 11.6 x 1.2 mm 64 ball FBGA
  - 8 x 11.6 x 1.4 mm 84 ball FBGA
- Operating Temperature
  - –25°C to +85°C
  - –40°C to +85°C

## General Description

The S71PL series is a product line of stacked Multi-Chip Product (MCP) packages and consists of:

- One or more S29PL (Simultaneous Read/Write) Flash memory die
- pSRAM or SRAM

The 256 Mb Flash memory consists of two S29PL127J devices. In this case, CE#f2 is used to access the second Flash and no extra address lines are required.

The products covered by this document are listed in the table below:

		Flash Memory Density			
		32Mb (1)	64Mb (1)	128Mb (2)	256Mb (2)
pSRAM Density	4 Mb	S71PL032J40			
	8 Mb	S71PL032J80	S71PL064J80		
	16 Mb	S71PL032JA0	S71PL064JA0		
	32 Mb		S71PL064JB0	S71PL127JB0	
	64 Mb			S71PL127JC0	S71PL254JC0

		Flash Memory Density	
		32Mb	64Mb
SRAM Density (1)	4 Mb	S71PL032J04	
	8 Mb	S71PL032J08	S71PL064J08
	16 Mb		S71PL064J0A

### Notes

1. Not recommended for new designs; contact your local Spansion sales representative for details.
2. Not recommended for new designs: use S71PL127N and S71PL256N instead.

For detailed specifications, please refer to the individual data sheets listed in the following table.

Document	Publication Identification Number (PID)
S29PL-J	S29PL-J_M0
pSRAM Type 1	psram_12
pSRAM Type 2	psram_15
8 Mb pSRAM Type 3	psram_25
16 Mb pSRAM Type 3	psram_06
pSRAM Type 4	psram_18
pSRAM Type 5	psram_21
pSRAM Type 6	psram_14
pSRAM Type 7	psram_13
4 Mb/8 Mb SRAM Type 1	sram_02
16 Mb SRAM Type 1	sram_06
SRAM Type 4	sram_07
32 Mb pSRAM Type 8	psram_31

**Note**

*None of these RAM specifications are applicable for new designs. Please contact your local Spansion sales representative for details.*

## 1. Product Selector Guide

### 1.1 32 Mb Flash Memory

Device-Model#	Flash Access time (ns)	(p)SRAM density	(p)SRAM Access time (ns)	pSRAM type	Package
S71PL032J04-0B	65	4M SRAM	70	SRAM1	TSC056
S71PL032J04-0K	65	4M SRAM	70	SRAM4	TSC056
S71PL032J40-0K	65	4M pSRAM	70	pSRAM4	TLC056
S71PL032J08-0B	65	8M SRAM	70	SRAM1	TSC056
S71PL032J80-0F	65	8M pSRAM	70	pSRAM5	TSC056
S71PL032J80-Q7	65	8M pSRAM	70	pSRAM1	TSC056
S71PL032J80-QF	65	8M pSRAM	70	pSRAM3	TSC056
S71PL032JA0-0K	65	16 Mb pSRAM	70	pSRAM1	TSC056
S71PL032JA0-QF	65	16 Mb pSRAM	70	pSRAM3	TSC056
S71PL032JA0-OZ	65	16M pSRAM	70	pSRAM7	TLC056

### 1.2 64 Mb Flash Memory

Device-Model#	Flash Access time (ns)	(p)SRAM density	(p)SRAM Access time (ns)	(p)SRAM type	Package
S71PL064J80-07	65	8M pSRAM	70	pSRAM4	TSC056
S71PL064J0A-0S	65	16M SRAM	70	SRAM 4	TLC056
S71PL064JA0-0Z	65	16M pSRAM	70	pSRAM7	TLC056
S71PL064JA0-0B	65	16M pSRAM	70	pSRAM3	TLC056
S71PL064JA0-07	65	16M pSRAM	70	pSRAM1	TLC056
S71PL064JA0-0P	65	16M pSRAM	70	pSRAM7	TLC056
S71PL064JB0-QB	65	32M pSRAM	70	pSRAM2	TLC056
S71PL064JB0-0U	65	32M pSRAM	70	pSRAM8	TLC056

### 1.3 128 Mb Flash Memory

Not recommended for new designs; use S71PL127N instead.

Device-Model#	Flash Access time (ns)	pSRAM density	pSRAM Access time (ns)	pSRAM type	Package
S71PL127JB0-9Z	65	32M pSRAM	70	pSRAM7	TLA064
S71PL127JB0-9U	65	32M pSRAM	70	pSRAM6	TLA064
S71PL127JB0-9B	65	32M pSRAM	70	pSRAM2	TLA064
S71PL127JC0-9B	65	64M pSRAM	70	pSRAM2	TLA064
S71PL127JC0-9Z	65	64M pSRAM	70	pSRAM7	TLA064
S71PL127JC0-9U	65	64M pSRAM	70	pSRAM6	TLA064

### 1.4 256Mb Flash Memory (2xS29PL127J)

Not recommended for new designs; use S71PL256N instead.

Device-Model#	Flash Access time (ns)	pSRAM density	pSRAM Access time (ns)	pSRAM type	Package
S71PL254JC0-TB	65	64M pSRAM	70	pSRAM2	FTA084
S71PL254JC0-TZ	65	64M pSRAM	70	pSRAM7	FTA084

## 2. MCP Block Diagram

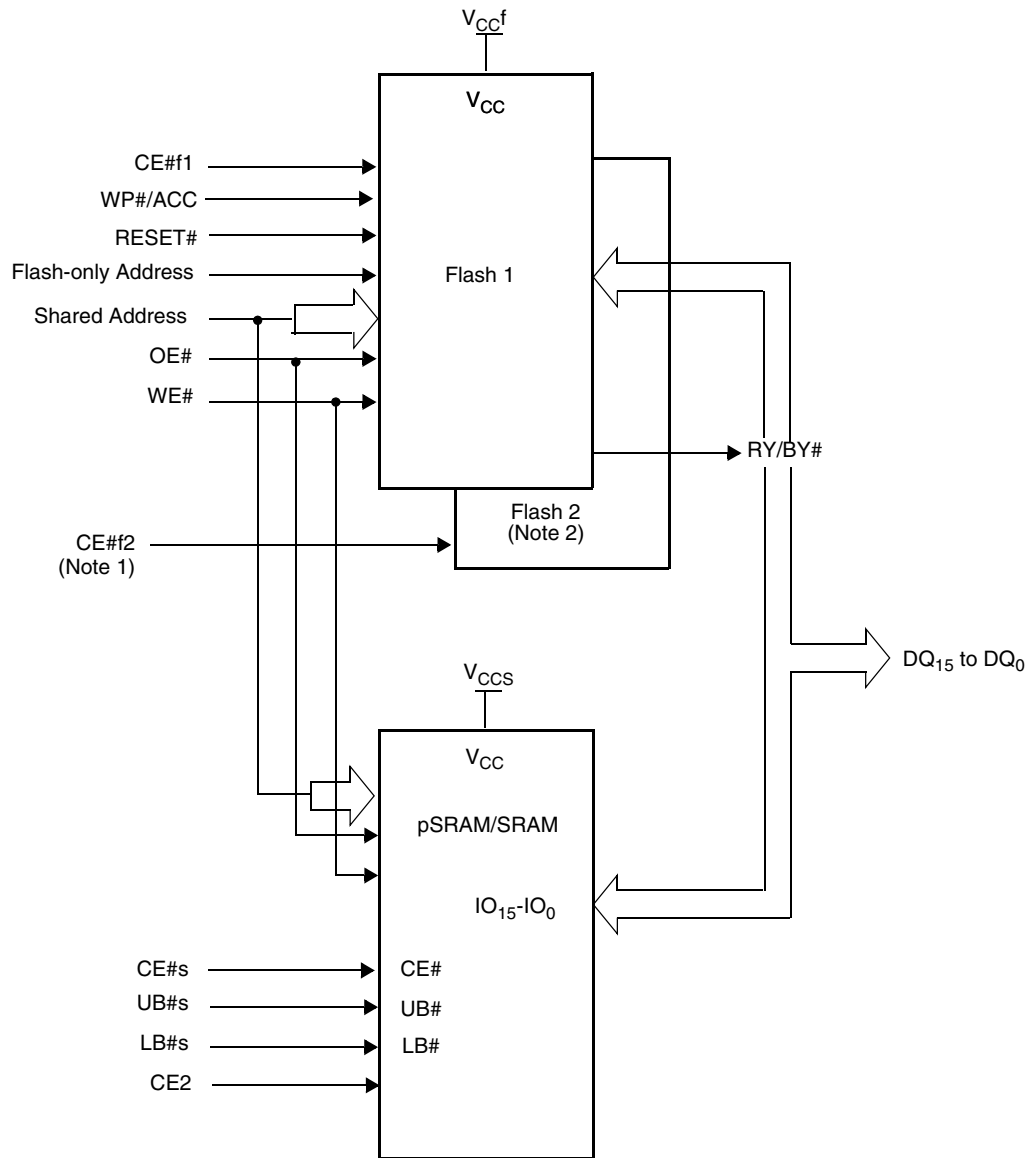

**Notes**

1. For 1 Flash + pSRAM, CE#f1=CE#. For 2 Flash + pSRAM, CE#=CE#f1 and CE#f2 is the chip-enable for the second Flash.
2. For 256Mb only, Flash 1 = Flash 2 = S29PL127J.

### 3. Connection Diagrams

**Figure 3.1** S71PL032J Connection Diagram

**56-ball Fine-Pitch Ball Grid Array**  
(Top View, Balls Facing Down)

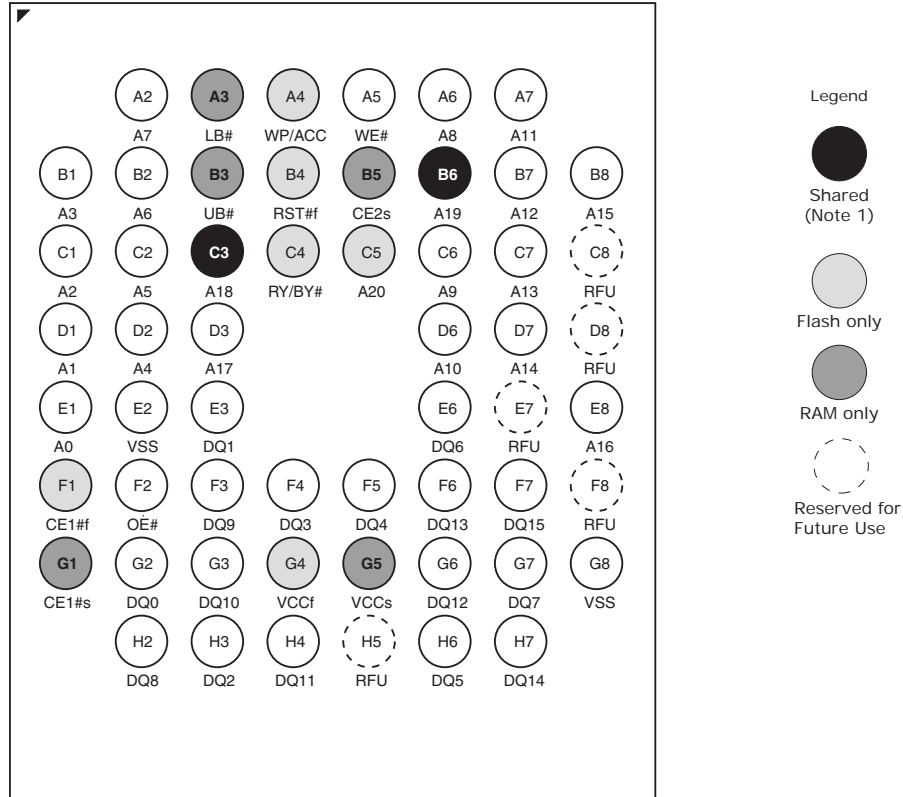

**Notes**

1. May be shared depending on density.
  - A19 is shared for the 16M pSRAM configuration.
  - A18 is shared for the 8M pSRAM and above configurations.
2. Connecting all  $V_{CC}$  and  $V_{SS}$  balls to  $V_{CC}$  and  $V_{SS}$  is recommended.

MCP	Flash-only Addresses	Shared Addresses
S71PL032JA0	A20	A19-A0
S71PL032J80	A20-A19	A18-A0
S71PL032J08	A20-A19	A18-A0
S71PL032J40	A20-A18	A17-A0
S71PL032J04	A20-A18	A17-A0

**Figure 3.2** S71PL064J Connection Diagram

56-ball Fine-Pitch Ball Grid Array  
(Top View, Balls Facing Down)

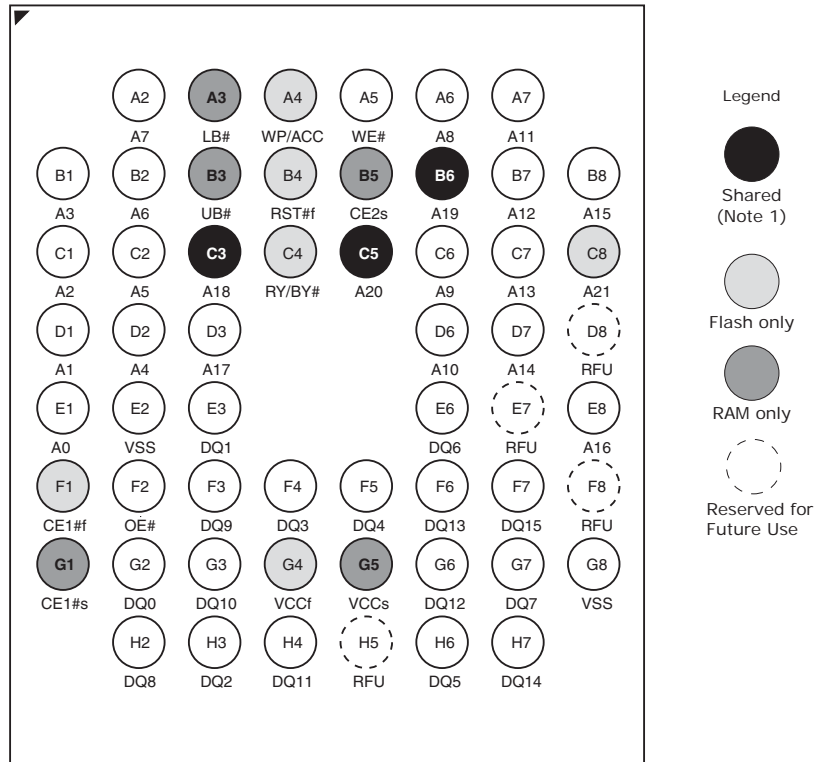

**Notes**

- May be shared depending on density.
  - A20 is shared for the 32M pSRAM configuration.
  - A19 is shared for the 16M pSRAM and above configurations.
  - A18 is shared for the 8M pSRAM and above configurations.
- Connecting all  $V_{CC}$  and  $V_{SS}$  balls to  $V_{CC}$  and  $V_{SS}$  is recommended.

MCP	Flash-only Addresses	Shared Addresses
S71PL064JB0	A21	A20-A0
S71PL064JA0	A21-A20	A19-A0
S71PL064J0A	A21-A20	A19-A0
S71PL064J80	A21-A19	A18-A0
S71PL064J08	A21-A19	A18-A0



**Figure 3.3** S71PL127J Connection Diagram

**64-ball Fine-Pitch Ball Grid Array**  
(Top View, Balls Facing Down)

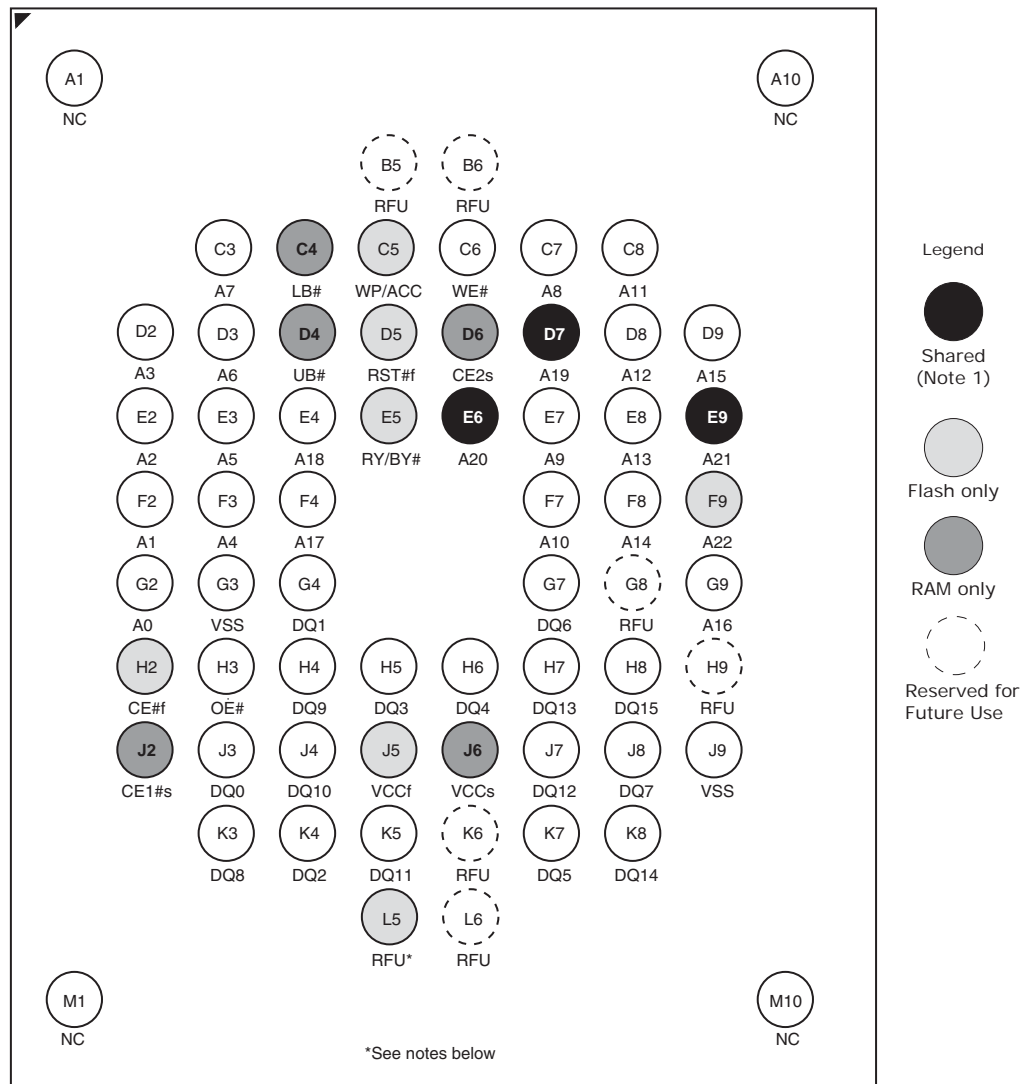

**Notes**

- May be shared depending on density.
  - A21 is shared for the 64M pSRAM configuration.
  - A20 is shared for the 32M pSRAM and above configurations.
- A19 is shared for the 16M pSRAM and above configurations

MCP	Flash-only Addresses	Shared Addresses
S71PL127JC0	A22	A21-A0
S71PL127JB0	A22-A21	A20-A0

- Connecting all  $V_{CC}$  and  $V_{SS}$  balls to  $V_{CC}$  &  $V_{SS}$  is recommended.
- Ball L5 will be  $V_{CC}F$  in the 84-ball density upgrades. Do not connect to  $V_{SS}$  or any other signal.

Figure 3.4 S71PL254J Connection Diagram

84-ball Fine-Pitch Ball Grid Array  
(Top View, Balls Facing Down)

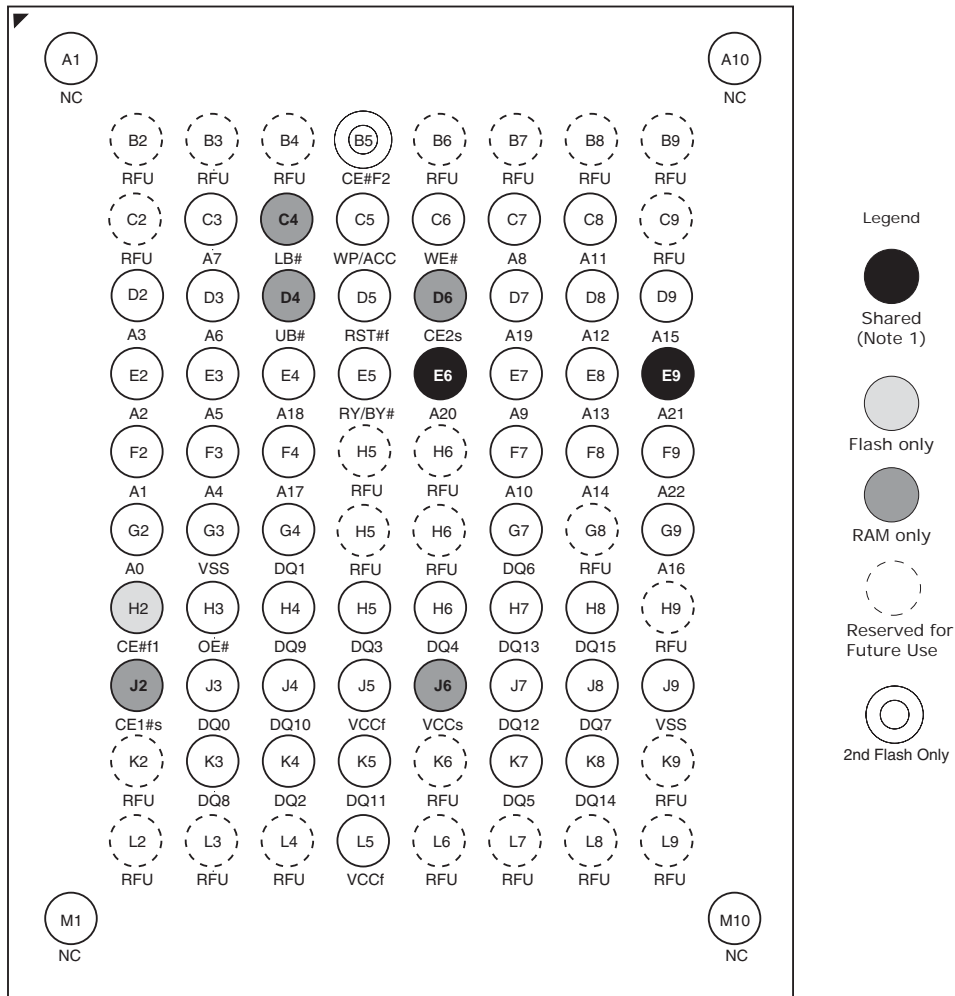

**Notes**

1. May be shared depending on density.
  - A21 is shared for the 64M pSRAM configuration.
  - A20 is shared for the 32M pSRAM configuration.

MCP	Flash-only Addresses	Shared Addresses
S71PL254JC0	A22	A21-A0

2. Connecting all  $V_{CC}$  &  $V_{SS}$  balls to  $V_{CC}$  &  $V_{SS}$  is recommended.

**Special Handling Instructions For FBGA Package**

Special handling is required for Flash Memory products in FBGA packages.

Flash memory devices in FBGA packages may be damaged if exposed to ultrasonic cleaning methods. The package and/or data integrity may be compromised if the package body is exposed to temperatures above 150° C for prolonged periods of time.

## 4. Pin Description

Signal	Description
A21–A0	22 Address Inputs (Common)
DQ15–DQ0	16 Data Inputs/Outputs (Common)
CE1#f	Chip Enable 1 (Flash)
CE#f2	Chip Enable 2 (Flash)
CE1#ps	Chip Enable 1 (pSRAM)
CE2ps	Chip Enable 2 (pSRAM)
OE#	Output Enable (Common)
WE#	Write Enable (Common)
RY/BY#	Ready/Busy Output (Flash 1)
UB#	Upper Byte Control (pSRAM)
LB#	Lower Byte Control (pSRAM)
RESET#	Hardware Reset Pin, Active Low (Flash 1)
WP#/ACC	Hardware Write Protect/Acceleration Pin (Flash)
V <sub>CCf</sub>	Flash 3.0 volt-only single power supply (see Product Selector Guide for speed options and voltage supply tolerances)
V <sub>CCps</sub>	pSRAM Power Supply
V <sub>SS</sub>	Device Ground (Common)
NC	Pin Not Connected Internally

## 5. Logic Symbol

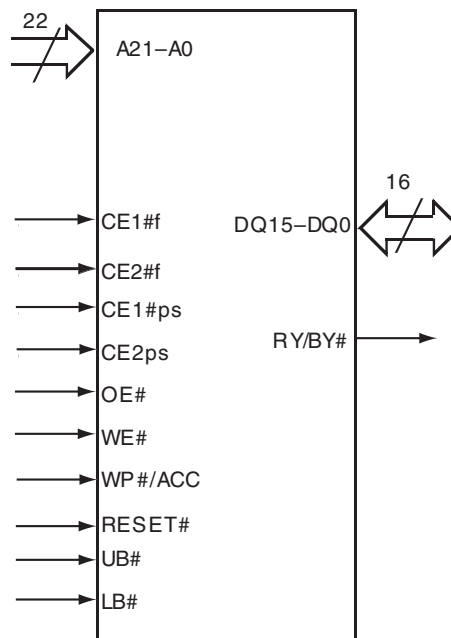

## 6. Ordering Information

The order number is formed by a valid combinations of the following:

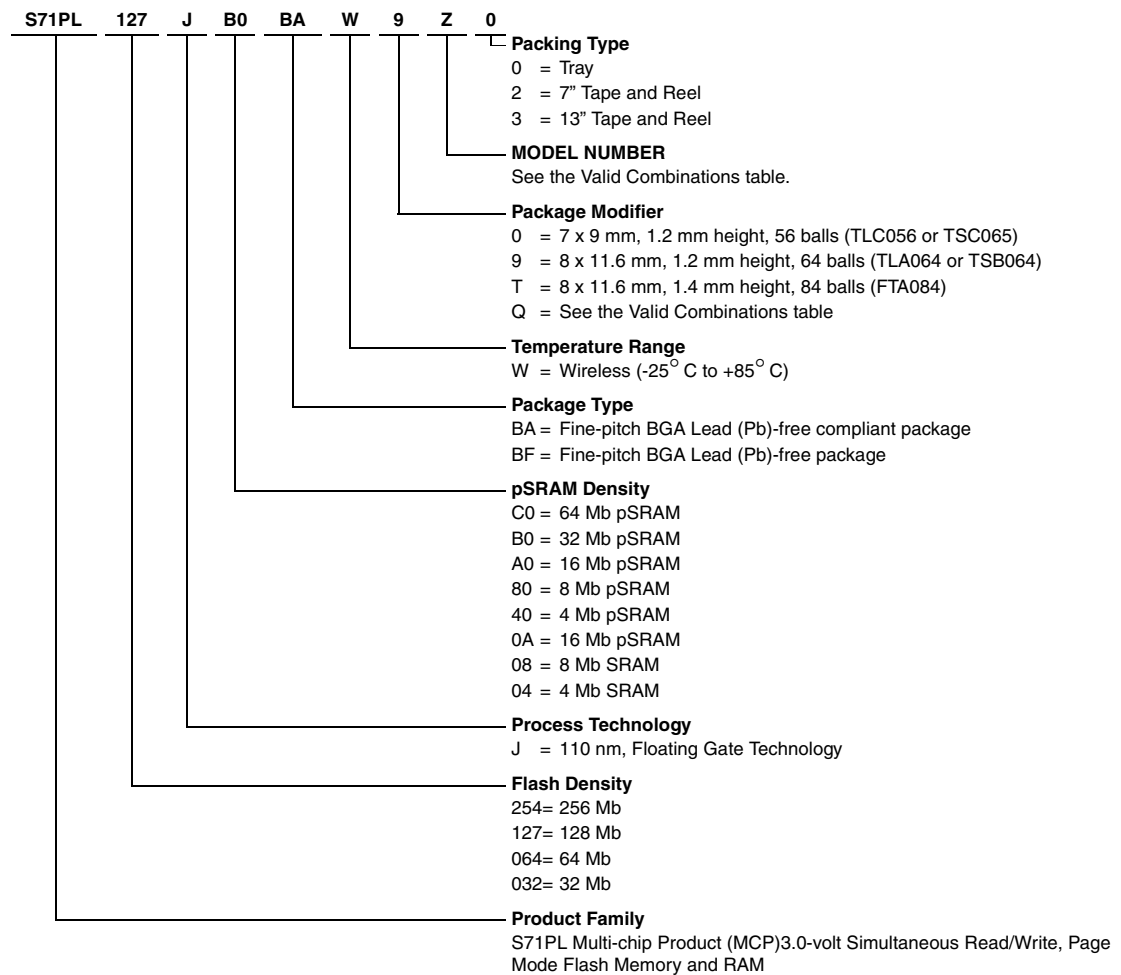

### 6.1 Valid Combinations

Valid Combinations list configurations planned to be supported in volume for this device. Consult your local sales office to confirm availability of specific valid combinations and to check on newly released combinations.

Table 6.1 S71PL032J Valid Combinations

Base Ordering Part Number	Package & Temperature	Package Modifier/ Model Number	Packing Type	Speed Options (ns)	(p)SRAM Type/ Access Time (ns)	Package Marking
S71PL032J04	BAW	0B	0, 2, 3 (1)	65	SRAM2 / 70	(2)
S71PL032J04		0K			SRAM4 / 70	
S71PL032J40		0K			pSRAM4 / 70	
S71PL032J80		0F			pSRAM5 / 70	
S71PL032J08		0B			SRAM2 / 70	
S71PL032J80		Q7			pSRAM1 / 70	
S71PL032J80		QF			pSRAM3 / 70	
S71PL032JA0		07			pSRAM1 / 70	
S71PL032JA0		QF			pSRAM3 / 70	
S71PL032JA0		0Z			pSRAM7 / 70	
S71PL032J04		BFW			0B	
S71PL032J04	0K		SRAM4 / 70			
S71PL032J40	0K		pSRAM4 / 70			
S71PL032J80	0F		pSRAM5 / 70			
S71PL032J08	0B		SRAM2 / 70			
S71PL032J80	Q7		pSRAM1 / 70			
S71PL032J80	QF		pSRAM3 / 70			
S71PL032JA0	07		pSRAM1 / 70			
S71PL032JA0	QF		pSRAM3 / 70			
S71PL032JA0	0Z		pSRAM7 / 70			

Table 6.2 S71PL064J Valid Combinations

Base Ordering Part Number	Package & Temperature	Package Modifier/ Model Number	Packing Type	Speed Options (ns)	(p)SRAM Type/ Access Time (ns)	Package Marking
S71PL064J80	BAW	07	0, 2, 3 (1)	65	pSRAM 4/70	(2)
S71PL064J0A		0S			SRAM1 / 70	
S71PL064JA0		0B			pSRAM3 / 70	
S71PL064JA0		07			pSRAM1 / 70	
S71PL064JA0		0P			pSRAM7 / 70	
S71PL064JB0		QB			pSRAM2 / 70	
S71PL064JB0		0U			pSRAM8 / 70	
S71PL064J80	BFW	07	0, 2, 3 (1)	65	pSRAM7 / 70	(2)
S71PI064J0A		0S			SRAM1 / 70	
S71PL064JA0		0B			pSRAM3 / 70	
S71PL064JA0		07			pSRAM1 / 70	
S71PL064JA0		0P			pSRAM7 / 70	
S71PL064JB0		QB			pSRAM2 / 70	
S71PL064JB0		0U			pSRAM8 / 70	

**Notes**

- Type 0 is standard. Specify other options as required.
- BGA package marking omits leading "S" and packing type designator from ordering part number.

**Table 6.3** S71PL127J Valid Combinations

Base Ordering Part Number	Package & Temperature	Package Modifier/ Model Number	Packing Type	Speed Options (ns)	(p)SRAM Type/ Access Time (ns)	Package Marking
S71PL127JB0	BAW	9Z	0, 2, 3 (1)	65	pSRAM7 / 70	(2)
S71PL127JB0		9U			pSRAM6 / 70	
S71PL127JC0		9B			pSRAM2 / 70	
S71PL127JC0		9Z			pSRAM7 / 70	
S71PL127JC0		9U			pSRAM6 / 70	
S71PL127JB0		9B			pSRAM2 / 70	
S71PL127JB0	BFW	9Z	0, 2, 3 (1)	65	pSRAM7 / 70	(2)
S71PL127JB0		9U			pSRAM6 / 70	
S71PL127JC0		9B			pSRAM2 / 70	
S71PL127JC0		9Z			pSRAM7 / 70	
S71PL127JC0		9U			pSRAM6 / 70	
S71PL127JB0		9B			pSRAM2 / 70	

**Notes**

1. Type 0 is standard. Specify other options as required.
2. BGA package marking omits leading "S" and packing type designator from ordering part number.

**Table 6.4** S71PL254J Valid Combinations

Base Ordering Part Number	Package & Temperature	Model Number	Packing Type	Speed Options (ns)	(p)SRAM Type/ Access Time (ns)	Package Marking
S71PL254JC0	BAW	TB	0, 2, 3 (1)	65	pSRAM2 / 70	(2)
S71PL254JC0		TZ			pSRAM7 / 70	
S71PL254JC0	BFW	TB	0, 2, 3 (1)	65	pSRAM2 / 70	(2)
S71PL254JC0		TZ			pSRAM7 / 70	

**Notes**

1. Type 0 is standard. Specify other options as required.
2. BGA package marking omits leading "S" and packing type designator from ordering part number.

## 7. Physical Dimensions

### TLC056—56-ball Fine-Pitch Ball Grid Array (FBGA) 9 x 7 mm Package

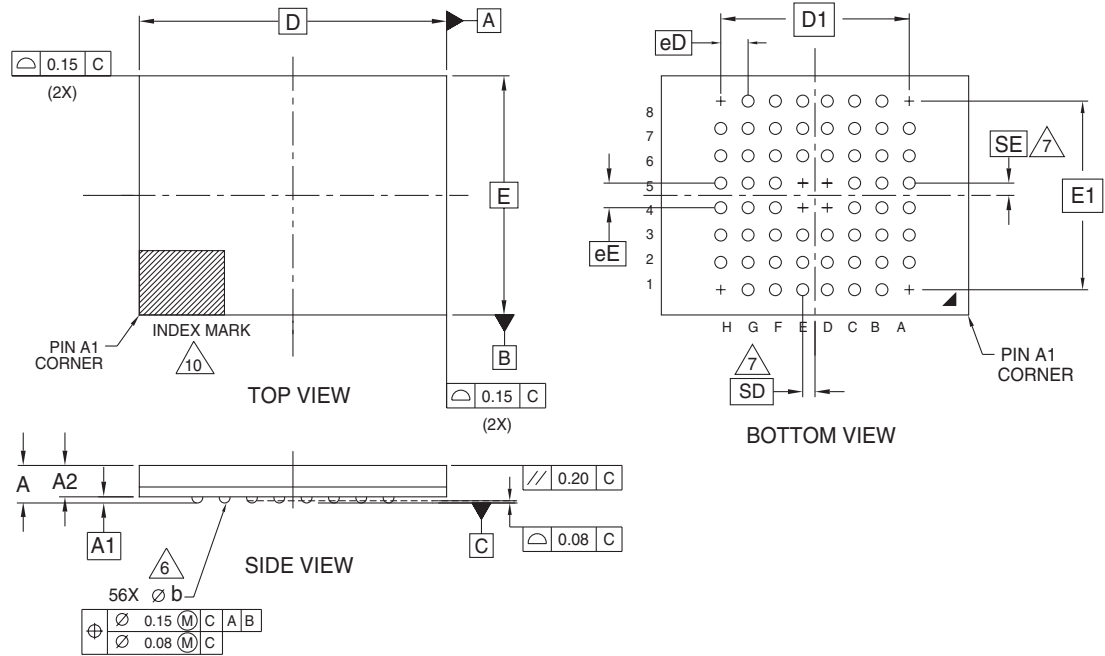

PACKAGE	TLC 056			NOTE
JEDEC	N/A			
D x E	9.00 mm x 7.00 mm PACKAGE			
SYMBOL	MIN	NOM	MAX	
A	---	---	1.20	PROFILE
A1	0.20	---	---	BALL HEIGHT
A2	0.81	---	0.97	BODY THICKNESS
D	9.00 BSC.			BODY SIZE
E	7.00 BSC.			BODY SIZE
D1	5.60 BSC.			MATRIX FOOTPRINT
E1	5.60 BSC.			MATRIX FOOTPRINT
MD	8			MATRIX SIZE D DIRECTION
ME	8			MATRIX SIZE E DIRECTION
n	56			BALL COUNT
φb	0.35	0.40	0.45	BALL DIAMETER
eE	0.80 BSC.			BALL PITCH
eD	0.80 BSC.			BALL PITCH
SD / SE	0.40 BSC.			SOLDER BALL PLACEMENT
	A1,A8,D4,D5,E4,E5,H1,H8			DEPOPULATED SOLDER BALLS

NOTES:

- DIMENSIONING AND TOLERANCING METHODS PER ASME Y14.5M-1994.
- ALL DIMENSIONS ARE IN MILLIMETERS.
- BALL POSITION DESIGNATION PER JESD 95-1, SPP-010.
- $e$  REPRESENTS THE SOLDER BALL GRID PITCH.
- SYMBOL "MD" IS THE BALL MATRIX SIZE IN THE "D" DIRECTION.  
SYMBOL "ME" IS THE BALL MATRIX SIZE IN THE "E" DIRECTION.  
n IS THE NUMBER OF POPULATED SOLDER BALL POSITIONS FOR MATRIX SIZE MD X ME.
- DIMENSION "b" IS MEASURED AT THE MAXIMUM BALL DIAMETER IN A PLANE PARALLEL TO DATUM C.
- SD AND SE ARE MEASURED WITH RESPECT TO DATUMS A AND B AND DEFINE THE POSITION OF THE CENTER SOLDER BALL IN THE OUTER ROW.
- WHEN THERE IS AN ODD NUMBER OF SOLDER BALLS IN THE OUTER ROW SD OR SE = 0.000.
- WHEN THERE IS AN EVEN NUMBER OF SOLDER BALLS IN THE OUTER ROW, SD OR SE =  $e/2$ .
- "+" INDICATES THE THEORETICAL CENTER OF DEPOPULATED BALLS.
- N/A
- A1 CORNER TO BE IDENTIFIED BY CHAMFER, LASER OR INK MARK, METALLIZED MARK INDENTATION OR OTHER MEANS.

3348 \ 16-038.22a

TSC056—56-ball Fine-Pitch Ball Grid Array (FBGA) 9 x 7 mm Package

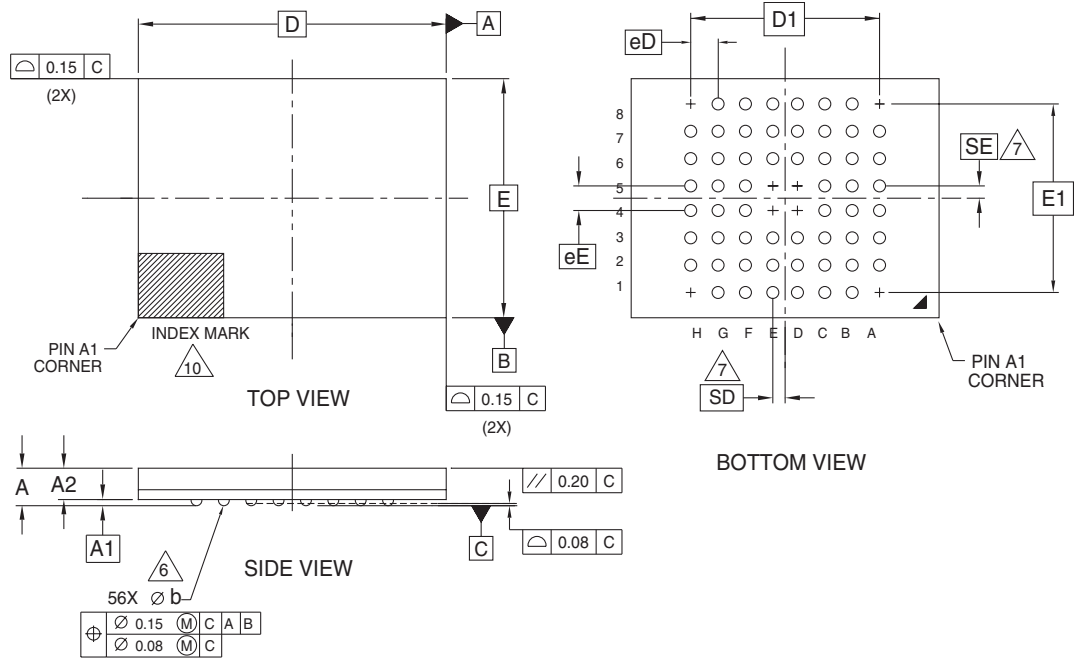

PACKAGE	TSC 056			
JEDEC	N/A			
D x E	9.00 mm x 7.00 mm PACKAGE			
SYMBOL	MIN	NOM	MAX	NOTE
A	---	---	1.20	PROFILE
A1	0.17	---	---	BALL HEIGHT
A2	0.81	---	0.97	BODY THICKNESS
D	9.00 BSC.			BODY SIZE
E	7.00 BSC.			BODY SIZE
D1	5.60 BSC.			MATRIX FOOTPRINT
E1	5.60 BSC.			MATRIX FOOTPRINT
MD	8			MATRIX SIZE D DIRECTION
ME	8			MATRIX SIZE E DIRECTION
n	56			BALL COUNT
$\phi b$	0.35	0.40	0.45	BALL DIAMETER
eE	0.80 BSC.			BALL PITCH
eD	0.80 BSC.			BALL PITCH
SD / SE	0.40 BSC.			SOLDER BALL PLACEMENT
	A1,A8,D4,D5,E4,E5,H1,H8			DEPOPULATED SOLDER BALLS

NOTES:

- DIMENSIONING AND TOLERANCING METHODS PER ASME Y14.5M-1994.
- ALL DIMENSIONS ARE IN MILLIMETERS.
- BALL POSITION DESIGNATION PER JESD 95-1, SPP-010.
- $e$  REPRESENTS THE SOLDER BALL GRID PITCH.
- SYMBOL "MD" IS THE BALL MATRIX SIZE IN THE "D" DIRECTION.  
SYMBOL "ME" IS THE BALL MATRIX SIZE IN THE "E" DIRECTION.  
n IS THE NUMBER OF POPULATED SOLDER BALL POSITIONS FOR MATRIX SIZE MD X ME.
- DIMENSION "b" IS MEASURED AT THE MAXIMUM BALL DIAMETER IN A PLANE PARALLEL TO DATUM C.
- SD AND SE ARE MEASURED WITH RESPECT TO DATUMS A AND B AND DEFINE THE POSITION OF THE CENTER SOLDER BALL IN THE OUTER ROW.
- WHEN THERE IS AN ODD NUMBER OF SOLDER BALLS IN THE OUTER ROW SD OR SE = 0.000.  
WHEN THERE IS AN EVEN NUMBER OF SOLDER BALLS IN THE OUTER ROW, SD OR SE =  $\lfloor e/2 \rfloor$
- "+" INDICATES THE THEORETICAL CENTER OF DEPOPULATED BALLS.
- N/A
- A1 CORNER TO BE IDENTIFIED BY CHAMFER, LASER OR INK MARK, METALLIZED MARK INDENTATION OR OTHER MEANS.

3427 \ 16-038.22



**TLA064—64-ball Fine-Pitch Ball Grid Array (FBGA) 8 x 11.6 mm Package**

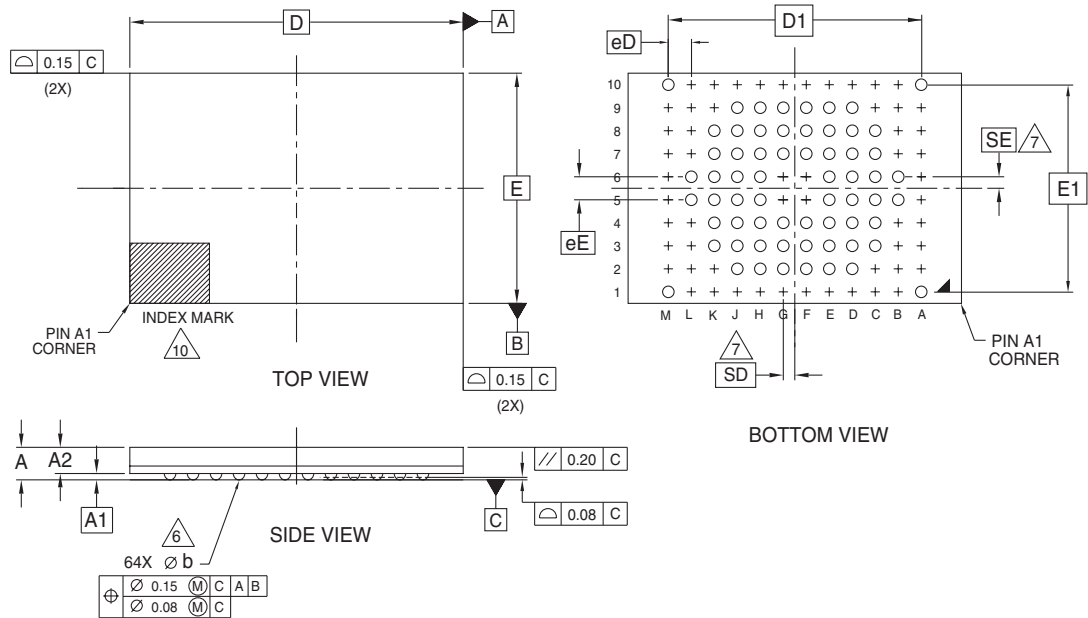

PACKAGE	TLA 064			
JEDEC	N/A			
D x E	11.60 mm x 8.00 mm PACKAGE			
SYMBOL	MIN	NOM	MAX	NOTE
A	---	---	1.20	PROFILE
A1	0.17	---	---	BALL HEIGHT
A2	0.81	---	0.97	BODY THICKNESS
D	11.60 BSC.			BODY SIZE
E	8.00 BSC.			BODY SIZE
D1	8.80 BSC.			MATRIX FOOTPRINT
E1	7.20 BSC.			MATRIX FOOTPRINT
MD	12			MATRIX SIZE D DIRECTION
ME	10			MATRIX SIZE E DIRECTION
n	64			BALL COUNT
φb	0.35	0.40	0.45	BALL DIAMETER
eE	0.80 BSC.			BALL PITCH
eD	0.80 BSC.			BALL PITCH
SD / SE	0.40 BSC.			SOLDER BALL PLACEMENT
	A2, A3, A4, A5, A6, A7, A8, A9, B1, B2, B3, B4, B7, B8, B9, B10, C1, C2, C9, C10, D1, D10, E1, E10, F1, F5, F6, F10, G1, G5, G6, G10, H1, H10, J1, J10, K1, K2, K9, K10, L1, L2, L3, L4, L7, L8, L9, L10, M2, M3, M4, M5, M6, M7, M8, M9			DEPOPULATED SOLDER BALLS

NOTES:

- DIMENSIONING AND TOLERANCING METHODS PER ASME Y14.5M-1994.
- ALL DIMENSIONS ARE IN MILLIMETERS.
- BALL POSITION DESIGNATION PER JESD 95-1, SPP-010.
- [e] REPRESENTS THE SOLDER BALL GRID PITCH.
- SYMBOL "MD" IS THE BALL MATRIX SIZE IN THE "D" DIRECTION.  
SYMBOL "ME" IS THE BALL MATRIX SIZE IN THE "E" DIRECTION.  
n IS THE NUMBER OF POPULATED SOLDER BALL POSITIONS FOR MATRIX SIZE MD X ME.
- △6 DIMENSION "b" IS MEASURED AT THE MAXIMUM BALL DIAMETER IN A PLANE PARALLEL TO DATUM C.
- △7 SD AND SE ARE MEASURED WITH RESPECT TO DATUMS A AND B AND DEFINE THE POSITION OF THE CENTER SOLDER BALL IN THE OUTER ROW.  
WHEN THERE IS AN ODD NUMBER OF SOLDER BALLS IN THE OUTER ROW SD OR SE = 0.000.  
WHEN THERE IS AN EVEN NUMBER OF SOLDER BALLS IN THE OUTER ROW, SD OR SE =  $\frac{e}{2}$
- "+" INDICATES THE THEORETICAL CENTER OF DEPOPULATED BALLS.
- N/A
- △10 A1 CORNER TO BE IDENTIFIED BY CHAMFER, LASER OR INK MARK, METALLIZED MARK INDENTATION OR OTHER MEANS.

3352 \ 16-038.22a

**TSB064—64-ball Fine-Pitch Ball Grid Array (FBGA) 8 x 11.6 mm Package**

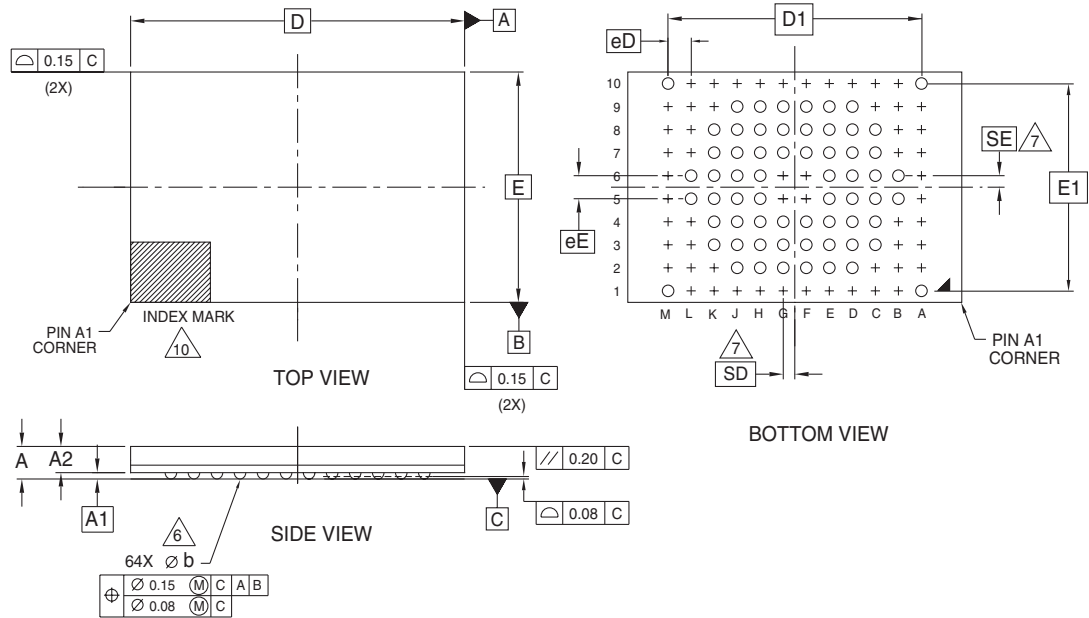

PACKAGE	TSB 064			
JEDEC	N/A			
D x E	11.60 mm x 8.00 mm PACKAGE			
SYMBOL	MIN	NOM	MAX	NOTE
A	---	---	1.20	PROFILE
A1	0.17	---	---	BALL HEIGHT
A2	0.81	---	0.97	BODY THICKNESS
D	11.60 BSC.			BODY SIZE
E	8.00 BSC.			BODY SIZE
D1	8.80 BSC.			MATRIX FOOTPRINT
E1	7.20 BSC.			MATRIX FOOTPRINT
MD	12			MATRIX SIZE D DIRECTION
ME	10			MATRIX SIZE E DIRECTION
n	64			BALL COUNT
$\phi$ b	0.35	0.40	0.45	BALL DIAMETER
eE	0.80 BSC.			BALL PITCH
eD	0.80 BSC.			BALL PITCH
SD / SE	0.40 BSC.			SOLDER BALL PLACEMENT
	A2, A3, A4, A5, A6, A7, A8, A9, B1, B2, B3, B4, B7, B8, B9, B10, C1, C2, C9, C10, D1, D10, E1, E10, F1, F5, F6, F10, G1, G5, G6, G10, H1, H10, J1, J10, K1, K2, K9, K10, L1, L2, L3, L4, L7, L8, L9, L10, M2, M3, M4, M5, M6, M7, M8, M9			DEPOPULATED SOLDER BALLS

NOTES:

- DIMENSIONING AND TOLERANCING METHODS PER ASME Y14.5M-1994.
- ALL DIMENSIONS ARE IN MILLIMETERS.
- BALL POSITION DESIGNATION PER JESD 95-1, SPP-010.
- [e] REPRESENTS THE SOLDER BALL GRID PITCH.
- SYMBOL "MD" IS THE BALL MATRIX SIZE IN THE "D" DIRECTION.  
SYMBOL "ME" IS THE BALL MATRIX SIZE IN THE "E" DIRECTION.  
n IS THE NUMBER OF POPULATED SOLDER BALL POSITIONS FOR MATRIX SIZE MD X ME.
- $\varnothing$  DIMENSION "b" IS MEASURED AT THE MAXIMUM BALL DIAMETER IN A PLANE PARALLEL TO DATUM C.
- $\varnothing$  SD AND SE ARE MEASURED WITH RESPECT TO DATUMS A AND B AND DEFINE THE POSITION OF THE CENTER SOLDER BALL IN THE OUTER ROW.
- WHEN THERE IS AN ODD NUMBER OF SOLDER BALLS IN THE OUTER ROW SD OR SE = 0.000.
- WHEN THERE IS AN EVEN NUMBER OF SOLDER BALLS IN THE OUTER ROW, SD OR SE =  $\lfloor \frac{e}{2} \rfloor$
- "+" INDICATES THE THEORETICAL CENTER OF DEPOPULATED BALLS.
- N/A
- $\varnothing$  A1 CORNER TO BE IDENTIFIED BY CHAMFER, LASER OR INK MARK, METALLIZED MARK INDENTATION OR OTHER MEANS.

3351 | 16-038.22a

**FTA084—84-ball Fine-Pitch Ball Grid Array (FBGA) 8 x 11.6 mm Package**

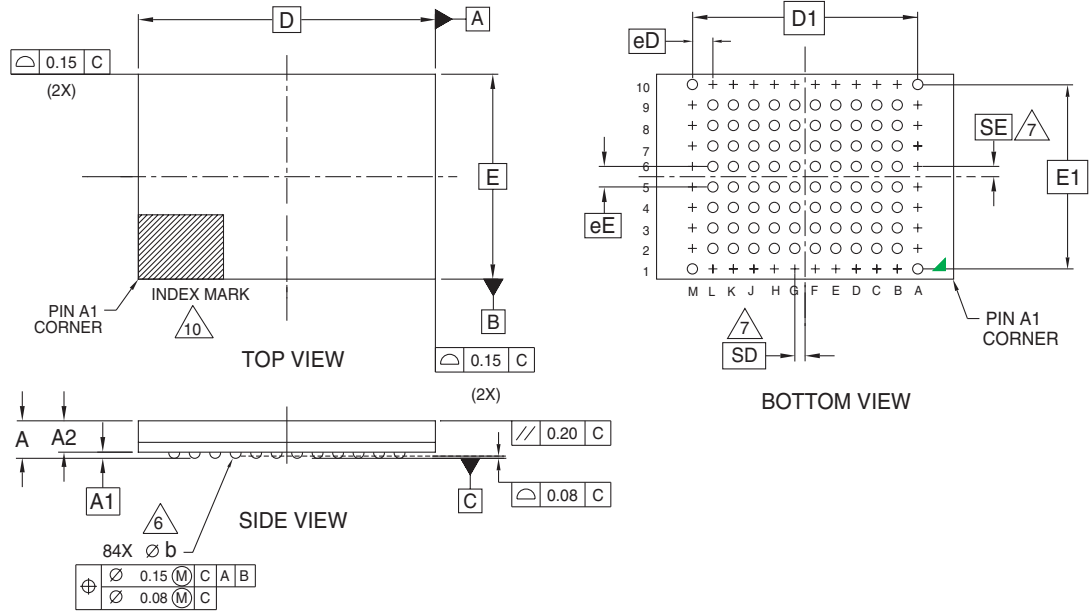

PACKAGE	FTA 084			NOTE
JEDEC	N/A			
D x E	11.60 mm x 8.00 mm PACKAGE			
SYMBOL	MIN	NOM	MAX	
A	---	---	1.40	PROFILE
A1	0.17	---	---	BALL HEIGHT
A2	1.02	---	1.17	BODY THICKNESS
D	11.60 BSC.			BODY SIZE
E	8.00 BSC.			BODY SIZE
D1	8.80 BSC.			MATRIX FOOTPRINT
E1	7.20 BSC.			MATRIX FOOTPRINT
MD	12			MATRIX SIZE D DIRECTION
ME	10			MATRIX SIZE E DIRECTION
n	84			BALL COUNT
$\varnothing b$	0.35	0.40	0.45	BALL DIAMETER
eE	0.80 BSC.			BALL PITCH
eD	0.80 BSC			BALL PITCH
SD / SE	0.40 BSC.			SOLDER BALL PLACEMENT
	A2,A3,A4,A5,A6,A7,A8,A9 B1,B10,C1,C10,D1,D10,E1,E10 F1,F10,G1,G10,H1,H10 J1,J10,K1,K10,L1,L10 M2,M3,M4,M5,M6,M7,M8,M9			DEPOPULATED SOLDER BALLS

NOTES:

- DIMENSIONING AND TOLERANCING METHODS PER ASME Y14.5M-1994.
- ALL DIMENSIONS ARE IN MILLIMETERS.
- BALL POSITION DESIGNATION PER JESD 95-1, SPP-010.
- $\square$  REPRESENTS THE SOLDER BALL GRID PITCH.
- SYMBOL "MD" IS THE BALL MATRIX SIZE IN THE "D" DIRECTION.  
SYMBOL "ME" IS THE BALL MATRIX SIZE IN THE "E" DIRECTION.  
n IS THE NUMBER OF POPULATED SOLDER BALL POSITIONS FOR MATRIX SIZE MD X ME.
- $\triangle 6$  DIMENSION "b" IS MEASURED AT THE MAXIMUM BALL DIAMETER IN A PLANE PARALLEL TO DATUM C.
- $\triangle 7$  SD AND SE ARE MEASURED WITH RESPECT TO DATUMS A AND B AND DEFINE THE POSITION OF THE CENTER SOLDER BALL IN THE OUTER ROW.
- WHEN THERE IS AN ODD NUMBER OF SOLDER BALLS IN THE OUTER ROW SD OR SE = 0.000.  
WHEN THERE IS AN EVEN NUMBER OF SOLDER BALLS IN THE OUTER ROW, SD OR SE =  $\frac{eD}{2}$
- "+" INDICATES THE THEORETICAL CENTER OF DEPOPULATED BALLS.
- N/A
- $\triangle 10$  A1 CORNER TO BE IDENTIFIED BY CHAMFER, LASER OR INK MARK, METALLIZED MARK INDENTATION OR OTHER MEANS.

3388 \ 16-038.21a

## 8. Revision History

Section	Description
<b>Revision A (May 3, 2004)</b>	
	Initial release
<b>Revision A1 (May 6, 2004)</b>	
Features	Corrected the high performance access times.
Connection Diagrams	Added reference points on all diagrams.
Ordering Information	Corrected package types. Corrected the description of product family to Page Mode Flash memory.
<b>Revision A2 (May 11, 2004)</b>	
General Description	Corrected the tables to reflect accurate device configurations.
<b>Revision A3 (June 16, 2004)</b>	
Ordering Information	Corrected the Valid Combinations tables to reflect accurate device configurations.
<b>Revision A4 (July 16, 2004)</b>	
Global	Global Change of FASL to Spansion. Global change to remove space between M and Mb callouts.
32 Mb Flash Memory	Replaced "S71PL032J08-07" with "S71PL032J08-0B". Replaced "S71PL032JA0" with "S71PL032JA0-07". Replaced "S71PL032JA0-08" with "S71PL032JA0-0F". Added row with the following content: S71PL032JA0-08; 65; 16Mb pSRAM; 70; pSRAM3; TLC056.
64 Mb Flash Memory	Replaced "S71PL064J08-0K" with "S71PL064J08-0B". Replaced "S71PL064J08-0P" with "S71PL064J08-0U". Deleted "S71PL064J80-05" row. Replaced "S71PL064JA0-07" with "S71PL064JA0-0K". Replaced "S71PL064JA0-0Z" with Added row with the following content: S71PL064JB0-07; 65; 32M pSRAM; 70; Ppsram 1; TLC056.
128 Mb Flash Memory	Added row with the following content: S71PL127JB0-9; 65; 32M pSRAM; 70; pSRAM; TLA064. Replaced "S71PL127JB0-97" with "S71PL127JB0-9Z". Added row with the following content: S71PL127JC0-97; 65; 64M pSRAM; 70; pSRAM1; TLA064. Replaced "S71PL127JC0-9P" with "S71PL127JC0-9Z". In the S71PL254JB0-TB row changed pSRAM type from "pSRAM3" to "pSRAM2".
256 Mb Flash Memory	Added row with the following content: S71PL254JB0-TB; 65; 32M pSRAM; 70; pSRAM3; FTA084. Added row with the following content: S71PL254JC0-TB; 65; 64M pSRAM; 70; pSRAM2; FTA084.
Connection Diagrams	Updated pins D8, D9, and L5. Added notes 2 and 3 to drawing. Updated pins D8 and D9. Added Note 2 to drawing.
S71PL032J Valid Combinations	Changed S71PL032J08 (p)SRAM Type Access Time (ns) from "SRAM1" to "SRAM2" (4 changes made in table). Changed S71PL032JA0 (p)SRAM Type Access Time (ns) from "SRAM3 / 70" to pSRAM3 / 70". Deleted all cells with the following collaborated text: "BAW,BFW, BAI, BFI". Merged previous place holder with cell above.
S71PL064J Valid Combinations	In (p)SRAM Type/Access Time (ns) changed all instances of "stet" to "pSRAM1/70". In Package Modifier/Model Number changed all instances of "stet" to "07". Added row to BAW Package and Temperature sections with the following content: S71PL064JB0; 07; 65 (previously inclusive); pSRAM1/70.
S71PL127J Valid Combinations	Changed the S71PL127JA0 Package Modifier/Model Number from "9Z" to "9P" (4 instances). Added 4 rows with the following content: S71PL127JC0; 97; pSRAM1/70.
S71PL254J Valid Combinations	Added 4 rows with the following content: S71PL254JC0; TB; pSRAM2/70. Added 4 rows with the following content: S71PL254JB0; TB; pSRAM2/70.

Section	Description
S71PL-J Based MCPs	Added 254M to Megabit indicator. Added 16 to CMOS indicator
<b>Revision A5 (September 14, 2004)</b>	
Product Selector Guide	Updated the 128Mb Flash Memory table.
Valid Combinations Table	Updated the S71PL127J Valid Combinations table.
<b>Revision A6 (November 22, 2004)</b>	
Product Selector Guide	Updated the 32Mb and 64Mb tables.
Valid Combinations Table	Updated the 32Mb and 64Mb combinations.
Physical Dimensions	Added the TSB064 package.
<b>Revision A7 (February 8, 2005)</b>	
pSRAM Type 7	Updated all information in this section
<b>Revision A8 (April 6, 2005)</b>	
S29PL-J Flash	Updated all information in this section
<b>Revision A9 (May 12, 2005)</b>	
Global	Added the S71PL064J0A option to cover the inclusion of the 16M SRAM
<b>Revision A10 (June 22, 2005)</b>	
Global	Removed 127/16 and 254/32 pSRAM and updated OPN for 64/16SRAM
<b>Revision A11 (July 29, 2005)</b>	
pSRAM Type 7	Updated this module
<b>Revision B (September 29, 2005)</b>	
S29PL-J Flash	Updated this module
SRAM Type 1	Updated this module
<b>Revision B1 (October 25, 2005)</b>	
pSRAM Type 5	Added this module
<b>Revision B2 (January 25, 2006)</b>	
Global	Added notices for devices not recommended for new designs Modified the Product Selection Guide Modified the S71PL032J, S71PL064J, S71PL127J Valid Combinations tables
<b>Revision B3 (March 17, 2006)</b>	
Global	Modified the structure of the document. Related data sheets are referenced rather than be embedded. Added data sheet reference table to that effect. Added the SRAM Type 4 option Added the 8Mb pSRAM Type 3 option
<b>Revision B4 (December 22, 2006)</b>	
Global	Added the S71PL064J80-07 for pSRAM Type 4 Removed the S71PL064J08-0B
<b>Revision B5 (July 17, 2007)</b>	
Global	Updated product status for all listed products
Ordering Information	Revised ordering information for S71PL032JA0 and S71PL064JB0 MCPs
<b>Revision B6 (February 17, 2010)</b>	
Ordering Information	Added Q description under Package Modifier

**Colophon**

The products described in this document are designed, developed and manufactured as contemplated for general use, including without limitation, ordinary industrial use, general office use, personal use, and household use, but are not designed, developed and manufactured as contemplated (1) for any use that includes fatal risks or dangers that, unless extremely high safety is secured, could have a serious effect to the public, and could lead directly to death, personal injury, severe physical damage or other loss (i.e., nuclear reaction control in nuclear facility, aircraft flight control, air traffic control, mass transport control, medical life support system, missile launch control in weapon system), or (2) for any use where chance of failure is intolerable (i.e., submersible repeater and artificial satellite). Please note that Spansion will not be liable to you and/or any third party for any claims or damages arising in connection with above-mentioned uses of the products. Any semiconductor devices have an inherent chance of failure. You must protect against injury, damage or loss from such failures by incorporating safety design measures into your facility and equipment such as redundancy, fire protection, and prevention of over-current levels and other abnormal operating conditions. If any products described in this document represent goods or technologies subject to certain restrictions on export under the Foreign Exchange and Foreign Trade Law of Japan, the US Export Administration Regulations or the applicable laws of any other country, the prior authorization by the respective government entity will be required for export of those products.

**Trademarks and Notice**

The contents of this document are subject to change without notice. This document may contain information on a Spansion product under development by Spansion. Spansion reserves the right to change or discontinue work on any product without notice. The information in this document is provided as is without warranty or guarantee of any kind as to its accuracy, completeness, operability, fitness for particular purpose, merchantability, non-infringement of third-party rights, or any other warranty, express, implied, or statutory. Spansion assumes no liability for any damages of any kind arising out of the use of the information in this document.

Copyright © 2004-2010 Spansion Inc. All rights reserved. Spansion®, the Spansion logo, MirrorBit®, MirrorBit® Eclipse™, ORNAND™, EcoRAM™ and combinations thereof, are trademarks and registered trademarks of Spansion LLC in the United States and other countries. Other names used are for informational purposes only and may be trademarks of their respective owners.