

High Voltage Sample and Hold Amplifier Array

General Description

The Supertex HV257DB2 is a 32-Channel, 295V, sample and hold amplifier array with a nominal gain of 72V/V. The purpose of the HV257DB2 is to provide a means to easily evaluate the Supertex HV257FG device. A high voltage supply, V_{PP}, and four low voltage supplies, AV_{DD} and DV_{DD}, AV_{NN} and DV_{NN}, are required. Referring to the demo board drawing shown below, the logic and VSIG connections are on the left, the high voltage outputs are on the bottom, and the supplies are on the right. Please follow the power up/down sequence to avoid damaging the device.

Specifications

Parameter	Value
V _{PP} , High voltage supply:	300V
AV _{DD} / DV _{DD} , Low voltage positive supply:	6.0 to 7.5V
AV _{NN} / DV _{NN} , Low voltage negative supply:	-4.5 to -6.5V
V _{SIG} , Input signal range:	0 to 5.0V
HV _{OUT} , Output voltage swing	0 to 295V
A _v , Closed loop gain	72V/V ±5%
SR, Output slew rate into 100pF load	2.0V/μs

Board Layout

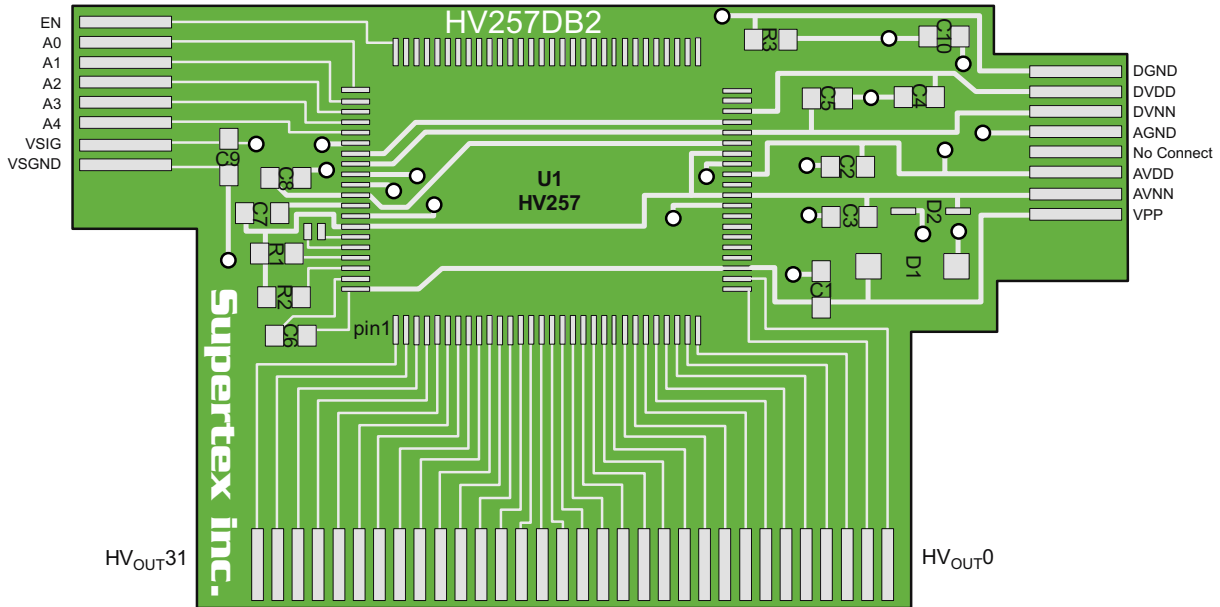

Power Up/Down Sequence

The device can be damaged due to improper power up/down sequence. To prevent damage, please follow the acceptable power up/down sequences. Two external diodes, D1 and D2, are added in the demo board to prevent damage during power Up/Down. The first diode is a high voltage diode across V_{PP} and AV_{DD}. Any low current high voltage diode can be used. The second diode can be any low voltage schottky diode across AV_{NN} and GND.

Acceptable Power Up Sequences

- 1) V_{PP} 2) V_{NN} 3) V_{DD} 4) Inputs & Anode
 or
 1) V_{NN} 2) V_{DD} 3) V_{PP} 4) Inputs & Anode

Acceptable Power Down Sequences

- 1) Inputs & Anode 2) V_{DD} 3) V_{NN} 4) V_{PP}
 or
 1) Inputs & Anode 2) V_{PP} 3) V_{DD} 4) V_{NN}

Inputs and Outputs

The output of the HV257FG will swing from 0V to 295V. The internal closed loop gain is set at 72V/V. An input voltage of 4.096V will give an output of 295V. Input voltages of up to 5.0V can be applied but will cause the amplifier to saturate. When EN is high, the addressed output, determined by A0 to A4, will be sampling the input signal VSIG. When EN is low, all the internal sampling switches are open.

The output current source and sink for all 32 channels can be adjusted using R1 and R2. The limit is approximately 12.5V divided by the resistor value. The demo board uses 24.9KΩ for ±500μA limiting.

Temperature Diode

The HV257FG has an integrated silicon diode to help monitor the die temperature if desired. Pin 95 is the anode and pin 96 is the cathode. Pads are available on the board for these connections.

Circuit Diagram

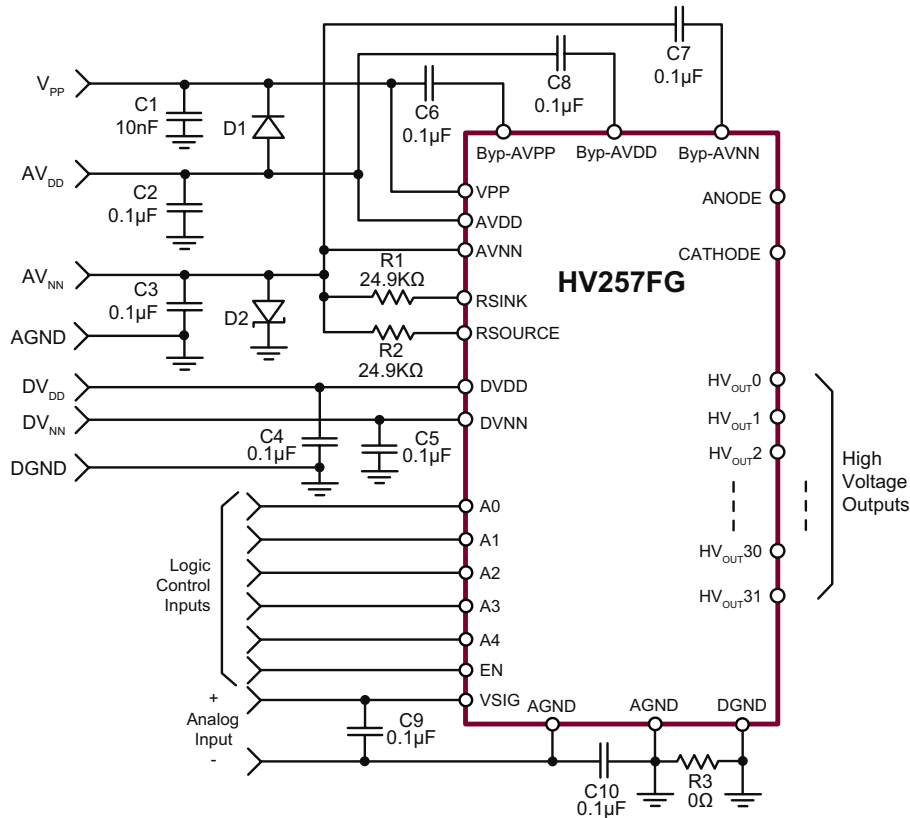

Bill of Materials

Part	Description	Value	Package	Manufacturer	Part Number
C1	X7R chip capacitor	500V, 0.01μF±10%	0805	Tecate	CMC-500103KX0805T
C2-C9	X7R chip capacitor	25V, 0.1μF±10%	0805	Tecate	CMC-025104KX0805T
C10	X7R chip capacitor	10V, 1.0μF±10%	0805	Any	---
R1	Chip resistor	24.9KΩ, ±1%	0805	Any	---
R2	Chip resistor	24.9KΩ, ±1%	0805	Any	---
R3	Chip resistor	0Ω	0805	Any	---
D1	Rectifier diode	400V, 1.0A	SMA	Diodes Inc	US1G
D2	Schottky diode	20V, 20mA	SOD-323	Diodes Inc	SD103CWS
U1	Amplifier array	300V	100-Lead MQFP	Supertex	HV257FG

Supertex inc. does not recommend the use of its products in life support applications, and will not knowingly sell them for use in such applications unless it receives an adequate "product liability indemnification insurance agreement." **Supertex inc.** does not assume responsibility for use of devices described, and limits its liability to the replacement of the devices determined defective due to workmanship. No responsibility is assumed for possible omissions and inaccuracies. Circuitry and specifications are subject to change without notice. For the latest product specifications refer to the **Supertex inc.** (website: <http://www.supertex.com>)