

TZA30x6

TIAs for TO-can-based ROSA applications up to 1250 Mbps

Designed for STM1/OC3, STM4/OC12, and FC/GE applications, these high-quality transimpedance preamplifiers have automatic gain control and provide low noise, a wide dynamic range, and low power dissipation.

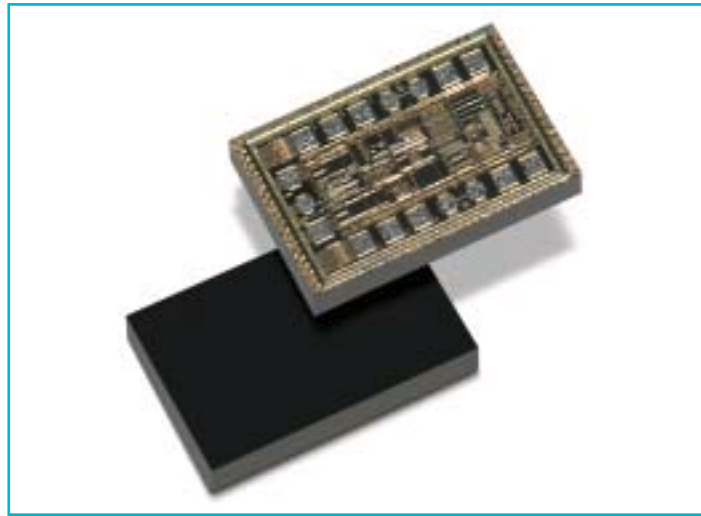

Key features

- High receiver sensitivity, low equivalent input noise
- Exceptionally wide bandwidths
- On-chip AGC with options for external control
- Input overload up to 1.5 mA pp
- Differential outputs
- Bias voltage for PIN diode
- Single 3.3-V supply voltage (range: 2.9 to 3.6 V)

Customer benefits

- Current output of average photo current for RSSI monitoring (SFF8472-compliant)
- Easy layout bonding
 - Identical ports available on both sides of die
 - RF polarity selection

Applications

- Digital fiber optic receiver modules (SFF/SFP transceivers)
 - Telecommunications transmission systems
 - High-speed data networks
 - FTTx systems

Semiconductors

The TZA30x6 family of transimpedance preamplifiers (TIAs) brings high receiver sensitivity, wide dynamic range, and low power dissipation to receiver optical sub assemblies (ROSA) applications that operate at up to 1250 Mbps. Each member of the family is optimized for a particular bit rate and transmission system.

Product No.	Bit Rate	Transmission System
TZA3036	155 Mbps	STM1/OC3
TZA3026	622 Mbps	STM4/OC12
TZA3046	1250 Mbps	FC/GE

The absence of offset control loops lets these devices operate from DC onwards and protects the output waveform from consecutive identical digits (CIDs).

High Receiver Sensitivity

By minimizing noise, TZA30x6 devices deliver exceptionally high receiver sensitivity. Typical noise levels, calculated with a lowpass bandwidth filter at a 0.7x bit rate and a source with an extinction ratio of 10% and a photodiode responsivity of 0.9 A/W, are -40 (TZA3036), -32 (TZA3026), and -29 (TZA3046).

Wide Dynamic Range

To prevent excessive distortion at the output stage, each TZA30x6 device has an integrated automatic gain control (AGC) loop that reduces the preamplifier's feedback resistance. The AGC loop can be controlled externally and includes a hold capacitor, reducing external chip-count.

TO-can Assemblies

Small size, identical ports on both sides, and RF polarity selection make TZA30x6 devices easy to use with cost-effective TO-can assemblies. Short bonding wires to ground improve overall performance.

PHILIPS

TZA30x6

TIAs for TO-can-based ROSA applications up to 1250 Mbps



TZA30x6 Transimpedance Preamplifiers

Product	Application	Bit Rate (Mbps)	Sensitivity (S) ¹	In (nARMS)	Overload (mApp)	Gain (kOhmdiff)	Flow (Hz)	Fhigh (-3dB)
TZA3036	STM1/OC3	155	-40	10	1.5	69.0	DC	160 MHz
TZA3026	STM4/OC12	622	-32	67	1.5	14.0	DC	650 MHz
TZA3046	FC/GE	1250	-29	130	1.5	9.0	DC	1050 MHz

¹ Calculated from noise figure using a lowpass bandwidth filter at 0.7x bit rate and a source with an extinction ratio of 10% and a photodiode responsivity of 0.9A/W.

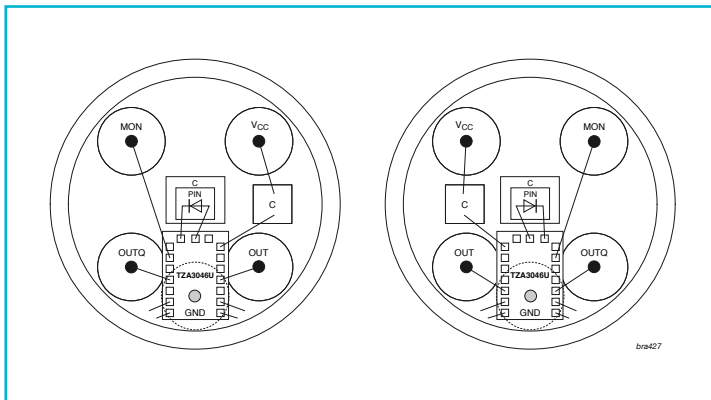

Possible TZA30x6 application highlighting flexible pad layout

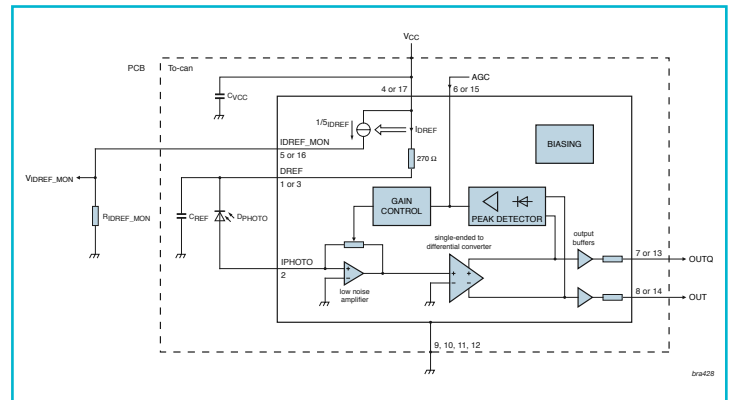

TZA30x6 application diagram

Philips Semiconductors

Philips Semiconductors is a worldwide company with over 100 sales offices in more than 50 countries. For a complete up-to-date list of our sales offices please e-mail sales.addresses@www.semiconductors.philips.com.

A complete list will be sent to you automatically.

You can also visit our website <http://www.semiconductors.philips.com/sales>.

© Koninklijke Philips Electronics N.V. 2005

All rights reserved. Reproduction in whole or in part is prohibited without the prior written consent of the copyright owner. The information presented in this document does not form part of any quotation or contract, is believed to be accurate and reliable and may be changed without notice. No liability will be accepted by the publisher for any consequence of its use. Publication thereof does not convey nor imply any license under patent- or other industrial or intellectual property rights.



Date of release: March 2005
Document order number: 9397 750 14859

Published in The Netherlands