

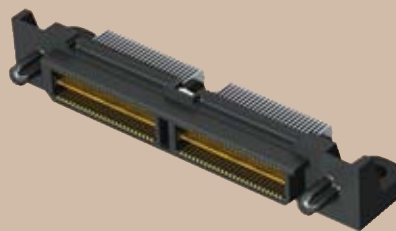

(0,635mm) .025"

QTS-RA SERIES



QTS-050-01-F-D-RA-WT

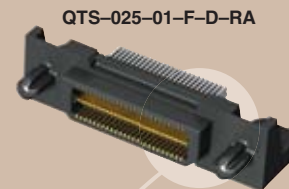

QTS-025-01-F-D-RA

RIGHT ANGLE GROUND PLANE HEADER

SPECIFICATIONS

For complete specifications and recommended PCB layouts see www.samtec.com?QTS-RA

Insulator Material:

Liquid Crystal Polymer



Terminal Material:

Phosphor Bronze

Plating:

Au or Sn over 50µ" (1,27µm) Ni

Current Rating:

1.2A @ 30°C Temperature Rise

Operating Temp Range:

-55°C to +125°C

Voltage Rating:

275 VAC mated with QSS-RA

RoHS Compliant:

Yes

Processing:

Lead-Free Solderable:

Yes

SMT Lead Coplanarity:

(0,10mm) .004" max (025-075)

(0,15mm) .006" max (100)

Board Mates:
QSS



APPLICATIONS

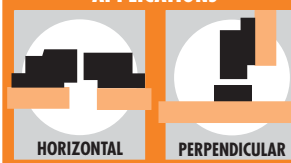

Integral metal plane for power or ground

Right Angle

Selectively plated

Guide Post



RUGGEDIZED
by SAMTEC

- Guide posts
- Weld tabs
- PCB mounting holes
- Solder pin option

APPLICATION SPECIFIC OPTION

- 30µ" (0,76µm) Gold
 - Differential Pair
 - "Partitionable" (combine differential & single-ended banks in same connector)
 - Lead Style for (2,36mm) .093" thick board
 - -LS1 Locking Screw (Mates with QSS-RA-LS1)
 - -LS2 Locking Screw (Mates with QSS-LS2)
- Call Samtec.

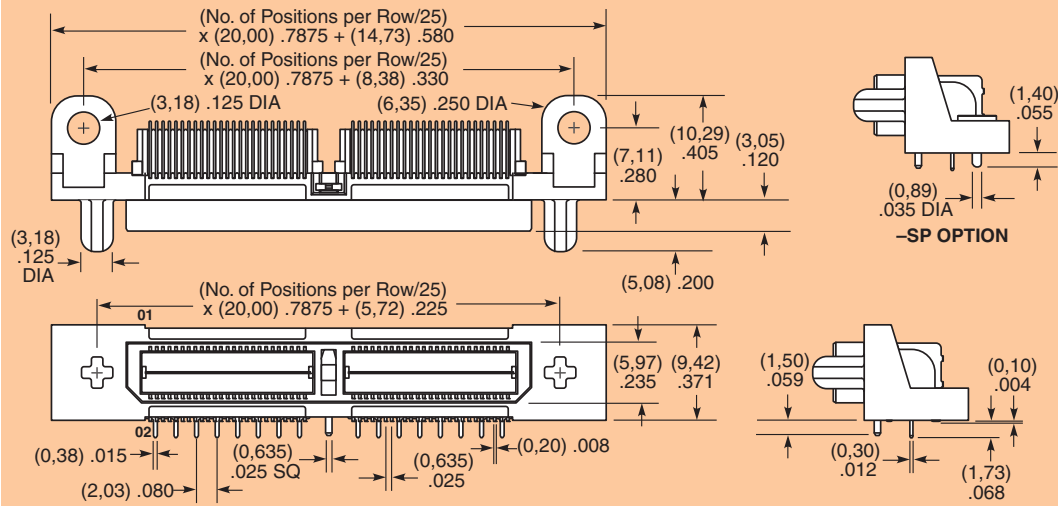
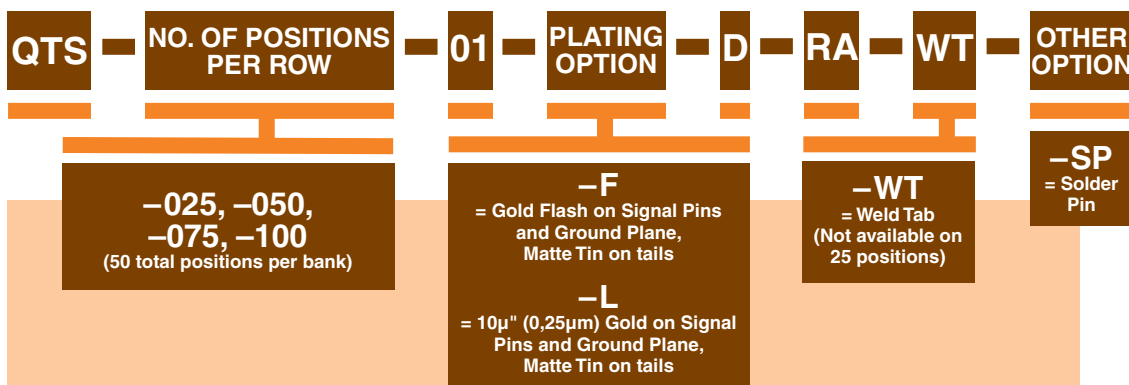

Note: Some lengths, styles and options are non-standard, non-returnable.

Due to technical progress, all designs, specifications and components are subject to change without notice.

WWW.SAMTEC.COM