

DESCRIPTION

The LX5245/5246 ICs are Low Voltage Differential (LVD) Terminators designed to comply with the LVD termination specification in the SPI-4 document. The LX5245/5246 are designed specifically for LVD applications. Because the LX5245/ 5246 support only LVD, they have lower output capacitance than multimode terminators such as the LX5241.

The LX5245/5246 Utilize Linfinity's UltraMAX Technology which delivers the ultimate in SCSI bus performance while saving component cost and board area. Elimination of the external capacitors also mitigates the need for a lengthy capacitor selection process. The individual high bandwidth drivers also maximize channel separation and reduces channel-to-channel noise and cross talk. The high-bandwidth UltraMAX architecture insures ULTRA-2 performance, while providing a clear migration path to ULTRA-3 and beyond.

When The LX5245/5246 Are Enabled, The Differential Sense (DIFFSENSE) Pin Supplies A Voltage Between 1.2V And 1.4V. In application, the terminator DIFFSENSE output is connected to the system DIFFSENSE line. If there are no single ended or HVD devices attached to the system the LVD output will be enabled. If the DIFFSENSE line is LOW, indicating a single ended device, the LX5245/ 5246 output will be HiZ. If the DIFFSENSE line is HIGH, indicating a high voltage differential device the LX5245/5246 output will be HiZ.

The LX5245/5246 ICs Have A TTL Compatible DISCONNECT Pin. The LX5245 is active LOW and the LX5246 is active HIGH. During sleep mode, power dissipation is reduced to a meager 5µA, while also placing all outputs in a HI Z state. Also during sleep mode, the DIFFSENSE function is disabled and is placed in a HI Z state.

IMPORTANT: For the most current data, consult MICROSEMI's website: <http://www.microsemi.com>

KEY FEATURES

- 2.5pF Typical Disabled Output Capacitance
- Fast Response, No External Capacitors Required
- 5µA Supply Current In Disconnect Mode
- 20mA Supply Current During Normal Operation
- Logic Command Disconnects All Termination Lines
- Diffsense Line Driver
- Current Limit And Thermal Protection
- Compliant With SPI-2 (Ultra2), SPI-3 (Ultra160),
- Mention 5249 as LVD Only Terminator With Pinout Compatible With Industry Standard Multi-mode Terminators
- Pin Compatible With Unitrode UCC5640

PRODUCT HIGHLIGHT

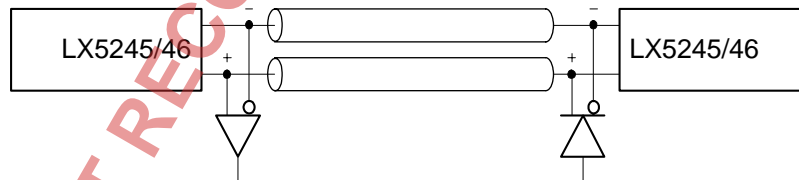
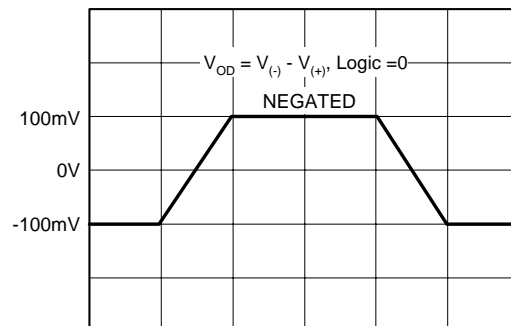
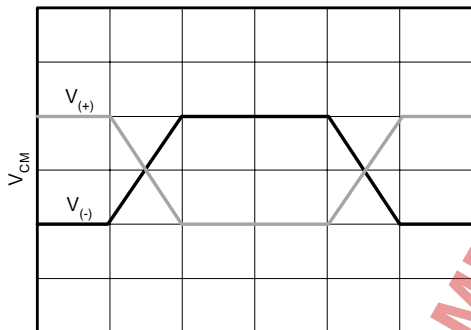

PACKAGE ORDER INFO

T _A (°C)	PW	Plastic TSSOP
		24-Pin
		RoHS / Pb-free Transition DC: 0442
0 to 70	LX5245CPW	
	LX5246CPW	

Note: Available in Tape & Reel. Append the letters "TR" to the part number. (i.e. LX5245CPW-TR)

9-LINE LVD SCSI TERMINATOR

PRELIMINARY DATA SHEET

ABSOLUTE MAXIMUM RATINGS (Note 1)

TermPwr Voltage	+6.5V
Signal Line Voltage	0V to 6.5V
Differential Voltage	0V to 6.5V
Operating Junction Temperature	
Plastic (PW Package)	150°C
Storage Temperature Range	-65°C to 150°C
Peak Package Solder Reflow Temperature (40 second maximum exp.).....	260°C(+0, -5)

Note 1. Exceeding these ratings could cause damage to the device. All voltages are with respect to Ground. Currents are positive into, negative out of the specified terminal.

THERMAL DATA

PW PACKAGE:

THERMAL RESISTANCE-JUNCTION TO AMBIENT, θ_{JA}	100°C/W
---	----------------

Junction Temperature Calculation: $T_j = T_A + (P_D \times \theta_{JA})$.
 The θ_{JA} numbers are guidelines for the thermal performance of the device/pc-board system. All of the above assume no ambient airflow.

PACKAGE PIN OUTS

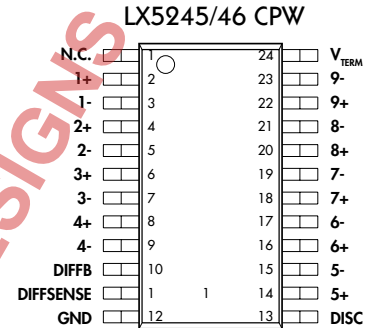

24L PW PACKAGE (Top View)
 ("N.C." = No Internal Connections)
 RoHS / Pb-free 100% Matte Tin Lead Finish

DIFFSENSE / POWER UP / POWER DOWN FUNCTION TABLE

LX5245 DISCONNECT	LX5246 DISCONNECT	DIFFSENSE	Outputs		Quiescent Current
			Status	Type	
L	H	L < 0.5V	Disable	HiZ	2mA
L	H	0.7V to 1.9V	Enable	LVD	21mA
L	H	H > 2.4V	Disable	HiZ	2mA
H	L	X	Disable	HiZ	10µA
Open	Open	X	Disable	HiZ	10µA

NOT RECOMMENDED FOR NEW DESIGNS

9-LINE LVD SCSI TERMINATOR

PRELIMINARY DATA SHEET

RECOMMENDED OPERATING CONDITIONS (Note 2)

Parameter	Symbol	Recommended Operating Conditions			Units
		Min.	Typ.	Max.	
TermPwr Voltage	V_{TERM}	3.0		5.25	V
Signal Line Voltage		0		5.0	V
Disconnect Input Voltage		0		V_{TERM}	V
Operating Junction Temperature Range LX5245 / 5246		0		70	°C

Note 2. Range over which the device is functional.

ELECTRICAL CHARACTERISTICS

(Unless otherwise specified, these specifications apply over the operating ambient temperature range of $0^{\circ}\text{C} \leq T_A \leq 70^{\circ}\text{C}$. TermPwr = 3.3V, DISCONNECT: LX5245 = L, LX5246 = H. Low duty cycle pulse testing techniques are used which maintains junction and case temperatures equal to the ambient temperature.)

Parameter	Symbol	Test Conditions	LX5245 / 5246			Units
			Min.	Typ.	Max.	
LVD Terminator Section						
TermPwr Supply Current	LVD I_{CC}	All term lines = Open DISCONNECT: LX5245 = H, LX5246 = L		21 5	25 10	mA μA
Common Mode Voltage	V_{OM}		1.125	1.25	1.375	V
Offset Voltage (fail safe bias voltage)	V_{OS}	Open circuit between - and + (see Note 3)	100	112	125	mV
Differential Terminator Impedance	Z_D	$V_{OD} = -1\text{V to } 1\text{V}$	100	105	110	Ω
Common Mode Impedance	Z_{CM}	0V to 2.5V	100	200	300	Ω
Output Capacitance	C_o	DISCONNECT: LX5245 = H, LX5246 = L		2.5		pF
Output Leakage	I_{Leak}	DISCONNECT: LX5245 = H, LX5246 = L, $V_{LINE} = 0$ to 4V, $T_A = 25^{\circ}\text{C}$ DISCONNECT: LX5245 = H, LX5246 = L, $V_{TERM} = 0\text{V}$, $V_{LINE} = 2.7\text{V}$		0 1	2	μA μA
Mode Change Delay	t_{DF}	DIFFSENSE = 1.4V to 0V	100	150		ms
DIFFSENSE Section						
DIFFSENSE Output Voltage	V_{DIFF}		1.2	1.3	1.4	V
DIFFSENSE Output Source Current	I_{DIFF}	DIFFSENSE = 0V	5.0		15.0	mA
DIFFSENSE Sink Current	$I_{SINK(DIFF)}$	$V_{IN} = 2.75\text{V}$			200	μA
DIFFSENSE Output Leakage	$I_{LEAK(DIFF)}$	DISCONNECT: LX5245 = H, LX5246 = L, $T_A = 25^{\circ}\text{C}$			10	μA
DISCONNECT Section						
DISCONNECT Threshold	V_{TH}		0.8		2.0	V
Input Current	I_{IH}	DISCONNECT: LX5245 = 0V DISCONNECT: LX5246 = 3.3V			10 10	μA μA

Note 3. Open circuit failsafe voltage.

9-LINE LVD SCSI TERMINATOR

PRELIMINARY DATA SHEET

FUNCTIONAL PIN DESCRIPTION

Pin Designator	Description
1-, 2-, 3-, 4-, 5-, 6-, 7-, 8-, 9-	Negative signal termination lines.
1+, 2+, 3+, 4+, 5+, 6+, 7+, 8+, 9+	Positive signal termination lines.
V_{TERM}	Power supply pin for terminator. Connect to SCSI bus TERMPWR. Must be decoupled by one 4.7 μ F low-ESR capacitor for every three terminator devices. It is absolutely necessary to connect this pin to the decoupling capacitor through a very low impedance (big traces on PCB). Keeping distances very short from the decoupling capacitors to the V_{TERM} pin is also critical. The value of the decoupling capacitor is somewhat layout dependant and some applications may benefit from high-frequency decoupling with 0.1 μ F capacitors right at V_{TERM} pin.
DISC	Enables / disables terminator. See Power Down Function Table for logic levels per device.
GND	Terminator ground pin. Connect to ground.
DIFFB	Used to detect the SCSI BUS mode (LVD, HVD, SE). Should be connected to 4.7 μ F to ground and 50k Ohm resistor to DIFFSENSE pin (See Figure 3).
DIFFSENSE	Differential sense pin connected to system DIFFSENSE line.

NOT RECOMMENDED FOR NEW DESIGNS

9-LINE LVD SCSI TERMINATOR

PRELIMINARY DATA SHEET

APPLICATION SCHEMATIC

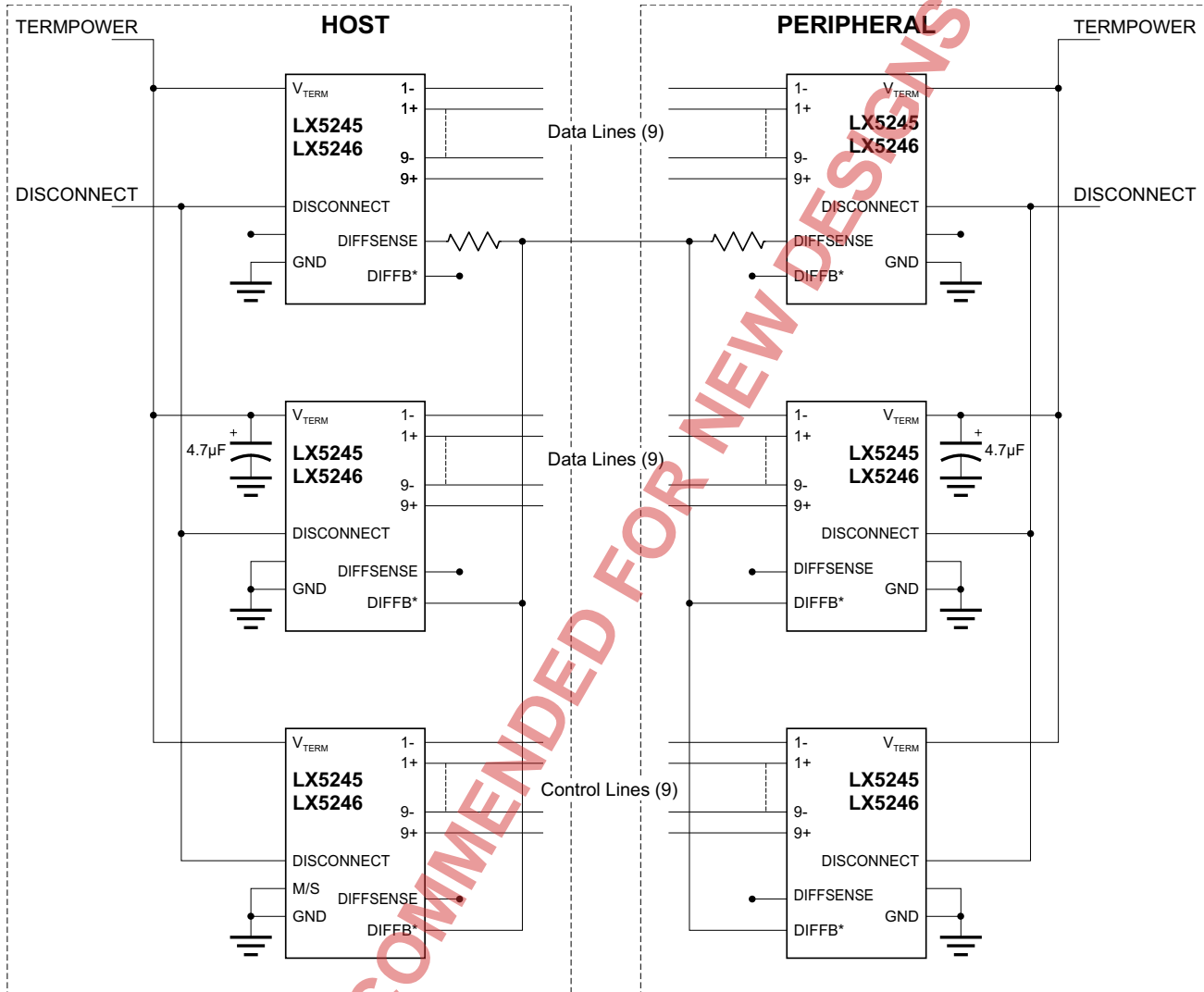

FIGURE 2 — Linfinity ONLY Application Schematic

NOT RECOMMENDED FOR NEW DESIGNS

9-LINE LVD SCSI TERMINATOR

PRELIMINARY DATA SHEET

APPLICATION SCHEMATIC

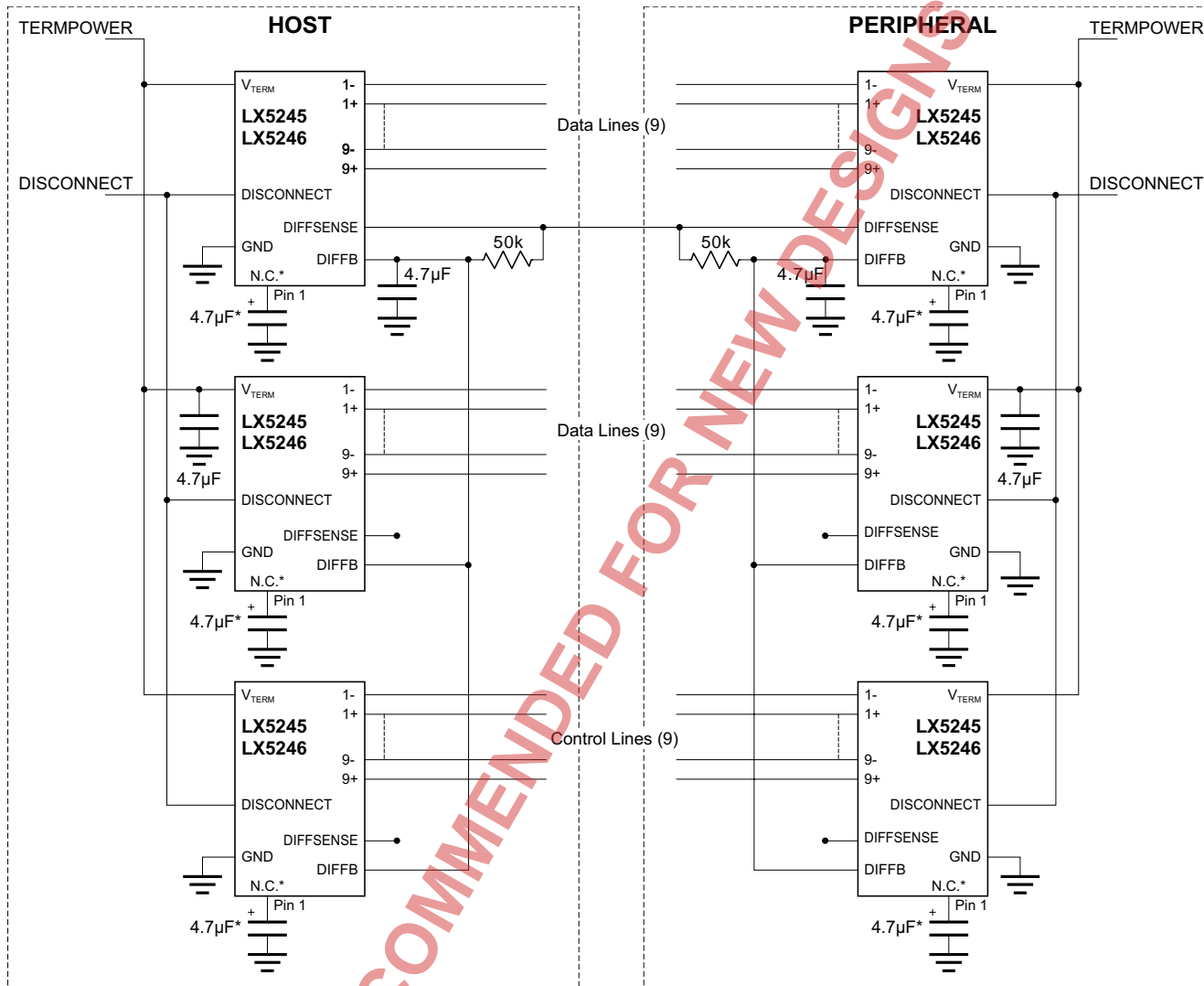

* The capacitor on Pin 1 can be placed on the LX5245CPW or LX5246CPW to be pin-compatible with other devices. This V_{REG}/REF capacitor is not required.

FIGURE 3 — Suggested Linfinitly LX5245/5246 Universal Application Schematic
(Please Reference Manufacturer's Current Data Sheet To Ensure Compatibility)

NOT RECOMMENDED FOR NEW DESIGNS

UltraMAX is a trademark of Linfinitly Microelectronics Inc.
Linfinitly is a division of Microsemi Inc.

PRELIMINARY DATA - Information contained in this document is pre-production data, and is proprietary to Linfinitly. It may not be modified in any way without the express written consent of Linfinitly. Product referred to herein is offered in sample form only, and Linfinitly reserves the right to change or discontinue this proposed product at any time.