

5 - 85 MHz 24-bit Color FPD-Link III Deserializer with HDCP

General Description

The DS90UH926Q deserializer, in conjunction with the DS90UH925Q serializer, provides a solution for secure distribution of content-protected digital video within automotive entertainment systems. This chipset translates a parallel RGB Video Interface into a single pair high-speed serialized interface. The digital video data is protected using the industry standard HDCP copy protection scheme. The serial bus scheme, FPD-Link III, supports full duplex of high speed forward data transmission and low speed backchannel communication over a single differential link. Consolidation of video data and control over a single differential pair reduces the interconnect size and weight, while also eliminating skew issues and simplifying system design.

The DS90UH926Q deserializer recovers the RGB data, three video control signals and three I2S audio signals. It extracts the clock from a high speed serial stream. An output LOCK pin provides the link status if the incoming data stream is locked, without the use of a training sequence or special SYNC patterns, as well as a reference clock.

The DS90UH926Q deserializer has a 30-bit parallel LVCMOS output interface to accommodate the RGB, video control, and audio data.

An adaptive equalizer optimizes the maximum cable reach. EMI is minimized by the input SSC tolerance (SSCT), output SSC generation (SSCG) and enhanced progressive turn-on (EPTO) features.

The HDCP cipher engine is implemented in both the serializer and deserializer. HDCP keys are stored in on-chip memory.

Features

- Integrated HDCP cipher engine with on-chip key storage
- Bidirectional control interface channel with I2C compatible support (400 Kbps)
- Supporting high definition (720p) digital video format
- RGB888 + VS, HS, DE and I2S audio supported
- 5 to 85 MHz PCLK support
- Single 3.3V Operation with 1.8V or 3.3V compatible LVCMOS I/O interface
- AC Coupled STP Interconnect up to 10 meters
- Parallel LVCMOS video outputs
- I2C compatible serial control bus for configuration
- DC Scrambled & Balanced Data w/ Embedded Clock
- Adaptive cable equalization
- @ SPEED Link BIST Mode
- Low power modes minimize power dissipation
- EMI Minimization (SSCT, SSCG and EPTO)
- Automotive grade product: AEC-Q100 Grade 2 qualified
- >8kV HBM and ISO 10605 ESD rating
- Backward compatible modes

Applications

- Automotive Display for Navigation
- Rear Seat Entertainment Systems

Applications Diagram

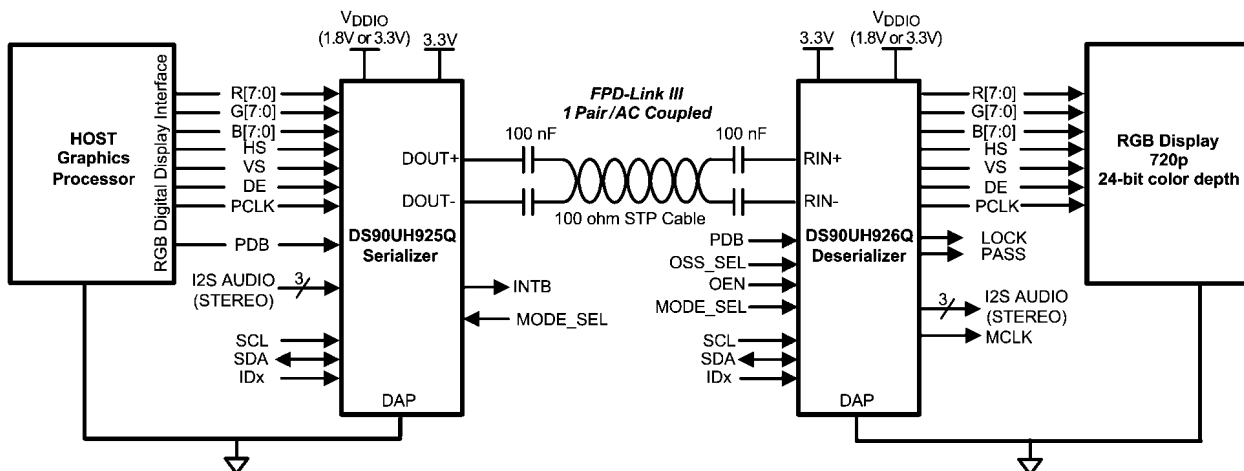

30136427

Block Diagram

The DS90UH926Q deserializer converts a serialized stream of information in FPD-Link III data format into video, audio, and I2C control data. This device is specifically designed for automotive environments. The device converts the serial

stream to parallel video, audio, and I2C control data, decrypts any HDCP protection, and then provides the data in an LVCMOS format to display and audio devices external to the chip. The device doesn't require any additional microcontroller support in the display to complete the HDCP decryption.

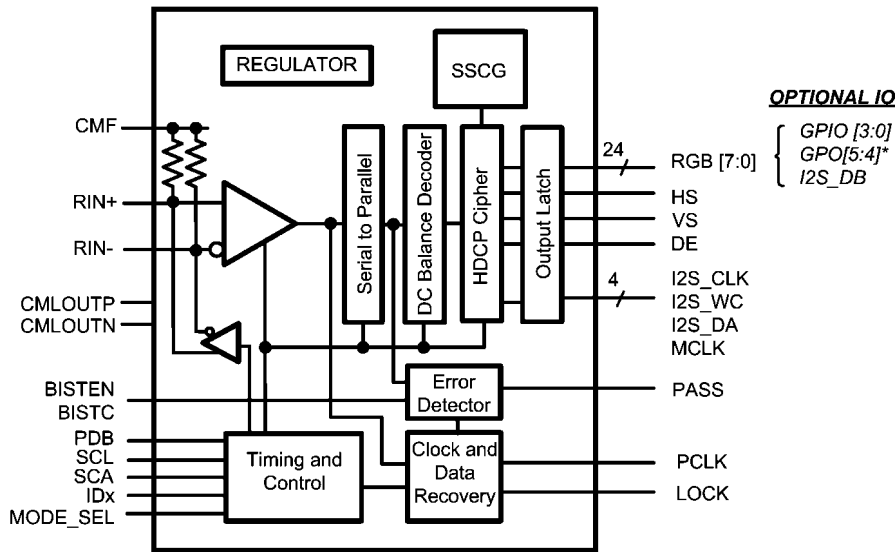

30136429

Application Information

The DS90UH925Q, in conjunction with the DS90UH926Q, is intended for interface between a HDCP compliant host (graphics processor) and a display. It supports a 24-bit color depth (RGB888) and high definition (720p) digital video format. It can receive a parallel RGB data with a pixel rate up to 85 MHz together with three control bits (VS, HS and DE) and three wire I2S-bus audio stream with an audio sampling rate up to 192 kHz. The included HDCP 1.3 compliant cipher block allows the authentication of the DS90UH926Q, which decrypts both video and audio contents. The keys are pre-loaded by National into Non-Volatile Memory (NVM) for maximum security.

HDCP Licensing Information

FPD-Link III is a fully approved High-bandwidth Digital Content Protection (HDCP) technology licensed by the Digital Content Protection LLC (DCP LLC). HDCP is a technology to protect the content of digital media. HDCP technology is required to distribute Blu-ray media and other high definition protected media content. Per the terms of the HDCP license, the DS90UH925 & DS90UH926 parts can only be provided to customers that are HDCP license adopters with the DCP LLC. For more information on how to become an HDCP license adopter, please contact the DCP directly at <http://www.digital-cp.com/>.

For More Information

For detailed information and samples of these products please contact your National Semiconductor sales representative.

Ordering Information

NSID	Package Description	Quantity	SPEC	Package ID
DS90UH926QSQE	60-pin LLP, 9.0 X 9.0 X 0.8 mm, 0.5 mm pitch	250	NOPB	SQA60B
DS90UH926QSQ	60-pin LLP, 9.0 X 9.0 X 0.8 mm, 0.5 mm pitch	1000	NOPB	SQA60B
DS90UH926QSQX	60-pin LLP, 9.0 X 9.0 X 0.8 mm, 0.5 mm pitch	2500	NOPB	SQA60B

Note: Automotive Grade (Q) product incorporates enhanced manufacturing and support processes for the automotive market, including defect detection methodologies. Reliability qualification is compliant with the requirements and temperature grades defined in the AEC Q100 standard. Automotive Grade products are identified with the letter Q. For more information go to <http://www.national.com/automotive>.

Physical Dimensions inches (millimeters) unless otherwise noted

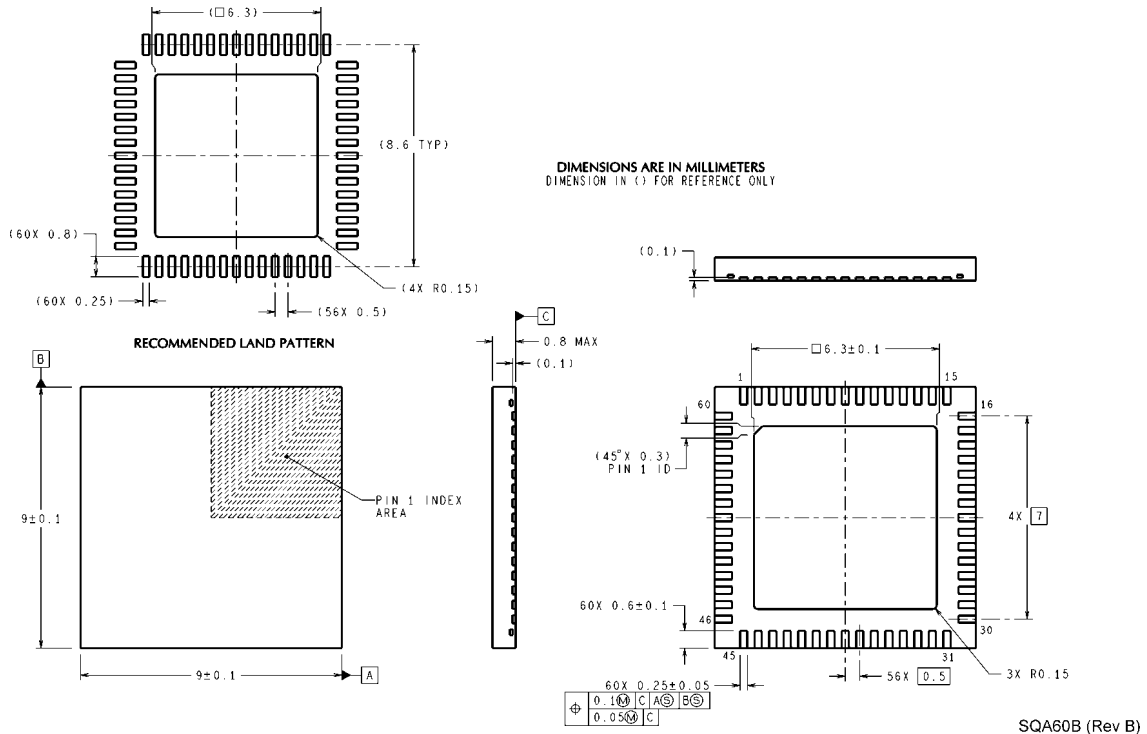

**60-pin LLP Package (9.0 mm x 9.0 mm x 0.8 mm, 0.5 mm pitch)
NS Package Number SQA60B**

Notes

For more National Semiconductor product information and proven design tools, visit the following Web sites at:
www.national.com

Products		Design Support	
Amplifiers	www.national.com/amplifiers	WEBENCH® Tools	www.national.com/webench
Audio	www.national.com/audio	App Notes	www.national.com/appnotes
Clock and Timing	www.national.com/timing	Reference Designs	www.national.com/refdesigns
Data Converters	www.national.com/adc	Samples	www.national.com/samples
Interface	www.national.com/interface	Eval Boards	www.national.com/evalboards
LVDS	www.national.com/lvds	Packaging	www.national.com/packaging
Power Management	www.national.com/power	Green Compliance	www.national.com/quality/green
Switching Regulators	www.national.com/switchers	Distributors	www.national.com/contacts
LDOs	www.national.com/lido	Quality and Reliability	www.national.com/quality
LED Lighting	www.national.com/led	Feedback/Support	www.national.com/feedback
Voltage References	www.national.com/vref	Design Made Easy	www.national.com/easy
PowerWise® Solutions	www.national.com/powerwise	Applications & Markets	www.national.com/solutions
Serial Digital Interface (SDI)	www.national.com/sdi	Mil/Aero	www.national.com/milaero
Temperature Sensors	www.national.com/tempensors	SolarMagic™	www.national.com/solarmagic
PLL/VCO	www.national.com/wireless	PowerWise® Design University	www.national.com/training

THE CONTENTS OF THIS DOCUMENT ARE PROVIDED IN CONNECTION WITH NATIONAL SEMICONDUCTOR CORPORATION ("NATIONAL") PRODUCTS. NATIONAL MAKES NO REPRESENTATIONS OR WARRANTIES WITH RESPECT TO THE ACCURACY OR COMPLETENESS OF THE CONTENTS OF THIS PUBLICATION AND RESERVES THE RIGHT TO MAKE CHANGES TO SPECIFICATIONS AND PRODUCT DESCRIPTIONS AT ANY TIME WITHOUT NOTICE. NO LICENSE, WHETHER EXPRESS, IMPLIED, ARISING BY ESTOPPEL OR OTHERWISE, TO ANY INTELLECTUAL PROPERTY RIGHTS IS GRANTED BY THIS DOCUMENT.

TESTING AND OTHER QUALITY CONTROLS ARE USED TO THE EXTENT NATIONAL DEEMS NECESSARY TO SUPPORT NATIONAL'S PRODUCT WARRANTY. EXCEPT WHERE MANDATED BY GOVERNMENT REQUIREMENTS, TESTING OF ALL PARAMETERS OF EACH PRODUCT IS NOT NECESSARILY PERFORMED. NATIONAL ASSUMES NO LIABILITY FOR APPLICATIONS ASSISTANCE OR BUYER PRODUCT DESIGN. BUYERS ARE RESPONSIBLE FOR THEIR PRODUCTS AND APPLICATIONS USING NATIONAL COMPONENTS. PRIOR TO USING OR DISTRIBUTING ANY PRODUCTS THAT INCLUDE NATIONAL COMPONENTS, BUYERS SHOULD PROVIDE ADEQUATE DESIGN, TESTING AND OPERATING SAFEGUARDS.

EXCEPT AS PROVIDED IN NATIONAL'S TERMS AND CONDITIONS OF SALE FOR SUCH PRODUCTS, NATIONAL ASSUMES NO LIABILITY WHATSOEVER, AND NATIONAL DISCLAIMS ANY EXPRESS OR IMPLIED WARRANTY RELATING TO THE SALE AND/OR USE OF NATIONAL PRODUCTS INCLUDING LIABILITY OR WARRANTIES RELATING TO FITNESS FOR A PARTICULAR PURPOSE, MERCHANTABILITY, OR INFRINGEMENT OF ANY PATENT, COPYRIGHT OR OTHER INTELLECTUAL PROPERTY RIGHT.

LIFE SUPPORT POLICY

NATIONAL'S PRODUCTS ARE NOT AUTHORIZED FOR USE AS CRITICAL COMPONENTS IN LIFE SUPPORT DEVICES OR SYSTEMS WITHOUT THE EXPRESS PRIOR WRITTEN APPROVAL OF THE CHIEF EXECUTIVE OFFICER AND GENERAL COUNSEL OF NATIONAL SEMICONDUCTOR CORPORATION. As used herein:

Life support devices or systems are devices which (a) are intended for surgical implant into the body, or (b) support or sustain life and whose failure to perform when properly used in accordance with instructions for use provided in the labeling can be reasonably expected to result in a significant injury to the user. A critical component is any component in a life support device or system whose failure to perform can be reasonably expected to cause the failure of the life support device or system or to affect its safety or effectiveness.

National Semiconductor and the National Semiconductor logo are registered trademarks of National Semiconductor Corporation. All other brand or product names may be trademarks or registered trademarks of their respective holders.

Copyright© 2010 National Semiconductor Corporation

For the most current product information visit us at www.national.com



National Semiconductor Americas Technical Support Center
 Email: support@nsc.com
 Tel: 1-800-272-9959

National Semiconductor Europe Technical Support Center
 Email: europe.support@nsc.com

National Semiconductor Asia Pacific Technical Support Center
 Email: ap.support@nsc.com

National Semiconductor Japan Technical Support Center
 Email: jpn.feedback@nsc.com