

FEATURES

- Small 14-Pin DIP
- Internal Hold Capacitor
- 2 μ sec Max Acquisition Time (10V Step to $\pm 0.01\%$, MN346)
- $\pm 10V$ Range, $G = -1$
- $\pm 3mV$ Max Offset
 $\pm 4mV$ Max Pedestal
- $\pm 0.5\mu V/\mu sec$ Max Droop Rate (MN346)
- Low Glitch 40mV
- Full Mil Operation
-55°C to +125°C
- MIL-PRF-38534 Screening Optional.

14 PIN DIP

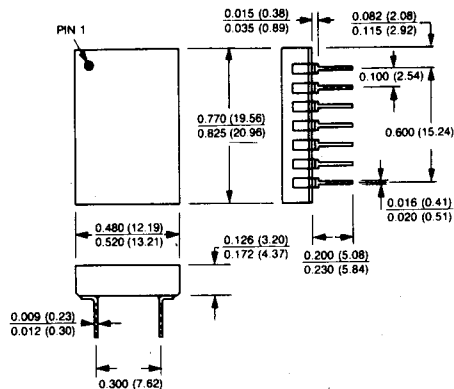

Dimensions in Inches
(millimeters)

DESCRIPTION

MN346 and MN347 are high-speed, adjustment-free track-hold amplifiers in small, 14-pin, hermetically sealed dual-in-line packages. Both units are complete with internal hold capacitor and incorporate a neutralization of track-to-hold charge offset that results in fast acquisition times and low pedestal errors. MN346 acquires a 10V step to $\pm 0.01\%$ in 2 μ sec. MN347 acquires a 10V step to $\pm 0.05\%$ in 3 μ sec. MN346 guarantees offset and pedestal errors to be less than $\pm 3mV$ and $\pm 4mV$ respectively. MN347 guarantees these errors to be less than $\pm 5mV$ and $\pm 8mV$ respectively.

Both MN346 and MN347 are functionally laser trimmed as complete units eliminating the need for user adjustment while saving the cost and space normally required for external components. A unique compensation scheme minimizes feedthrough and track-hold-track glitches. Maximum droop rate is $\pm 0.5\mu V/\mu sec$ for the MN346 and $\pm 1.5\mu V/\mu sec$ for the MN347.

MN346 and MN347 are available for operation over the full -55°C to +125°C temperature range, and high reliability processing, screening and qualification according to MIL-PRF-38534 are available for military/aerospace applications.

MN346 and MN347 offer the circuit designer very fast acquisition times and the convenience of a one-component track-hold function at low cost. These track-holds find application in D/A deglitching, in high-speed data distribution systems and in high-speed, simultaneously-sampling or sequential data acquisition systems requiring high scan rates. Small size and weight combined with reliable thin-film hybrid construction and specs guaranteed from -55°C to +125°C make these track-holds particularly well suited for military, avionics and aerospace applications.

MN346 MN347 HIGH-SPEED T/H AMPLIFIERS
ABSOLUTE MAXIMUM RATINGS

Operating Temperature Range	-55°C to +125°C
Specified Temperature Range:	
MN346, MN347	0°C to +70°C
MN346H, H/B; MN347H, H/B	-55°C to +125°C
Storage Temperature Range	-65°C to +150°C
+15V Supply (+Vcc, Pin 11)	-0.5 to +18 Volts
-15V Supply (-Vcc, Pin 14)	+0.5 to -18 Volts
Analog Input (Pin 13)	±15 Volts
Digital Input (Pin 1)	-0.5 to +7 Volts
Output Current (Note 1)	±20mA

ORDERING INFORMATION

PART NUMBER _____ MN346H/B CH

Select MN346 or MN347: _____

Standard Part is specified for 0°C to +70°C operation.

Add "H" suffix for specified -55°C to +125°C operation. _____

Add "YB" to "H" devices for Environmental Stress Screening. _____

Add "CH" to "H/B" devices for 100% screening according to MIL-PRF-38534. _____

SPECIFICATIONS (T_A = +25°C, ±Vcc = ±15V unless otherwise indicated) (Note 2)

ANALOG INPUT/OUTPUT	MIN.	TYP.	MAX.	UNITS
Input/Output Voltage Range (Note 4)	±10	±11		Volts
Input Resistance (Note 3)		3		kΩ
Output Current (Note 1)	±3			mA
DIGITAL INPUT				
Logic Levels: Logic "1" (Track Mode)	+2.0			Volts
Logic "0" (Hold Mode)			+0.8	Volts
Logic Currents: Logic "1" (V _{IH} = +2.4V)			+1	μA
Logic "0" (V _{IL} = +0.4V)			-150	μA
TRANSFER CHARACTERISTICS				
Gain		-1		V/V
Gain Linearity Error (Note 5)		±0.005	±0.01	%FSR
Gain Accuracy: Initial (+25°C): MN346		±0.01	±0.02	%
MN347		±0.03	±0.05	%
Over Temperature (Note 6): MN346		±0.03	±0.05	%
MN347		±0.06	±0.1	%
Offset Voltage (Track Mode, Note 7): Initial (+25°C): MN346		±1	±3	mV
MN347		±2	±5	mV
Over Temperature (Note 6)		±6	±20	mV
Pedestal (Note 8): Initial (+25°C): MN346		±2	±4	mV
MN347		±4	±8	mV
Over Temperature (Note 6)		±10	±20	mV
DYNAMIC CHARACTERISTICS				
Acquisition Time: MN346: 10V Step to ±0.01% (±1mV)		1	2	μsec
20V Step to ±0.01% (±2mV)		1.6	3	μsec
MN347: 10V Step to ±0.05% (±5mV)		1	3	μsec
20V Step to ±0.05% (±10mV)		1.6	4	μsec
Track-to-Hold Transient (Note 9): Amplitude (Note 3)		±40		mV
Settling Time to ±1mV		150	500	nsec
Aperture Delay Time (Note 3)		30		nsec
Aperture Jitter (Note 3)		400		psec
Output Slew Rate (Note 3)		±50		V/μsec
Full Power Bandwidth (10Vp-p, -3dB, Note 3)		1.4		MHz
Output Droop Rate: MN346: Initial (+25°C)		±0.1	±0.5	μV/μsec
0°C to +70°C		±20	±60	μV/μsec
-55°C to +125°C		±200	±700	μV/μsec
MN347: Initial (+25°C)		±0.5	±1.5	μV/μsec
0°C to +70°C		±60	±150	μV/μsec
-55°C to +125°C		±700	±1500	μV/μsec
Feedthrough Attenuation (@1kHz)		0.005	0.02	%
POWER SUPPLIES				
Voltage Range (Note 4)	±12	±15	±16	Volts
Power Supply Rejection Ratio (Note 3)		±100		μV/V
Current Drains: +15V Supply		+20	+28	mA
-15V Supply		-17	-25	mA
Power Consumption		640	795	mW

SPECIFICATION NOTES:

1. MN346/347's output is short-circuit protected and units can withstand sustained shorts to ground or either supply with current limiting at approximately $\pm 20\text{mA}$. In normal operation, output current should not exceed $\pm 3\text{mA}$.
2. Listed specifications apply for both MN346 and MN347 unless otherwise indicated.
3. These parameters are listed for reference only and are not tested.
4. Maximum output voltage swing is typically $\pm V_{cc} \pm 4\text{V}$.
5. FS stands for full scale and is equivalent to 10 Volts. FSR stands for full scale range and is equivalent to 20 Volts. For a 12-bit system, $1 \text{ LSB} = 0.024\% \text{FSR}$.
6. Unless otherwise indicated, listed specifications apply over the 0°C to $+70^\circ\text{C}$ temperature range for MN346 and MN347 and over the -55°C to $+125^\circ\text{C}$ temperature range for MN346H, MN346H/B, MN347H and MN347H/B.
7. Adjustable to zero with user-optional external potentiometer.
8. Pedestal refers to the unwanted step in output voltage that occurs as a T/H is switched from the track to the hold mode. For many T/H's, pedestal amplitude is a function of input/output voltage level. For the MN346 and MN347, pedestal is constant regardless of input/output level.
9. Track-to-hold settling time refers to the time interval between the point at which a device is commanded from the track to the hold mode and the point at which the analog output (following a transient) settles to within a specified error band around its final value.

BLOCK DIAGRAM

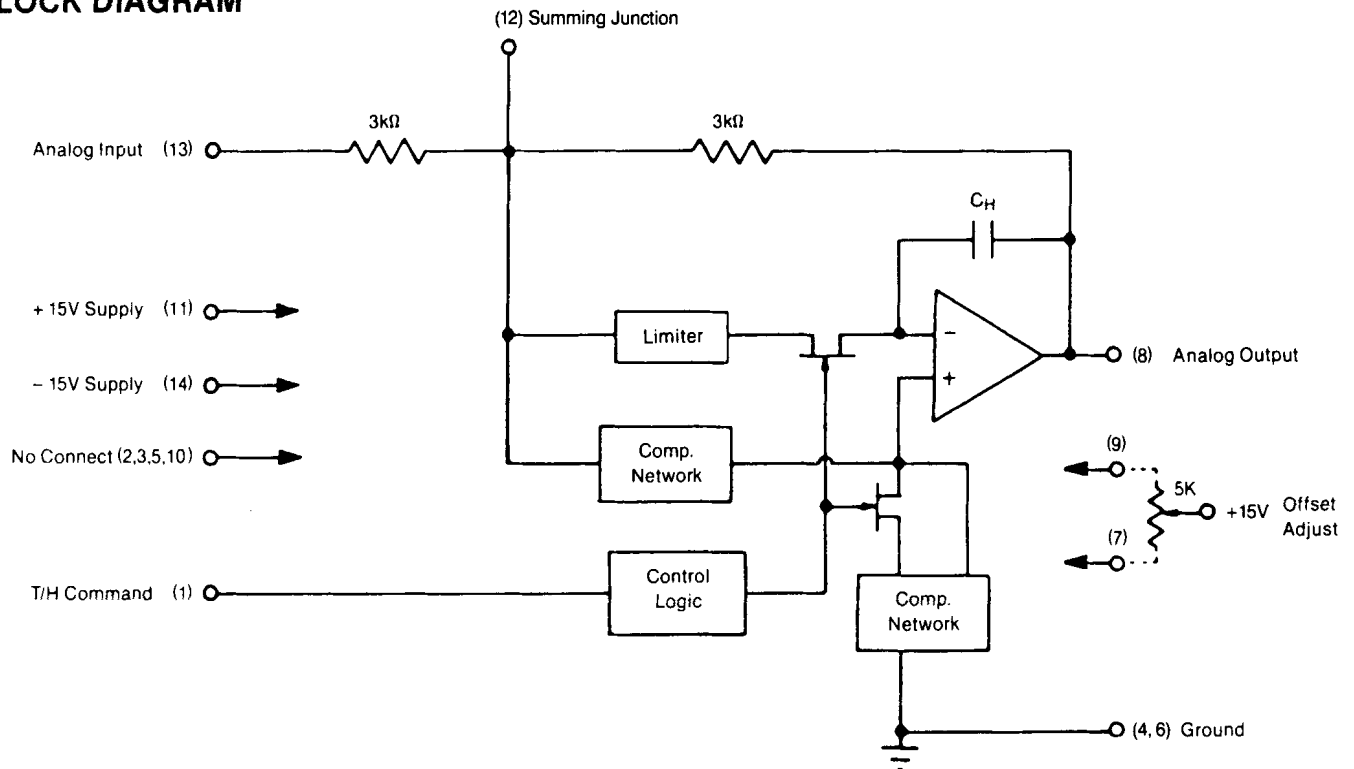

PIN DESIGNATIONS

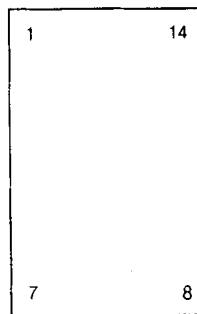

- | | |
|-----------------|-----------------------|
| 1 T/H Command | 14 -15V Supply (-Vcc) |
| 2 No Connect | 13 Analog Input |
| 3 No Connect | 12 Summing Junction |
| 4 Ground | 11 +15V Supply (+Vcc) |
| 5 No Connect | 10 No Connect |
| 6 Ground | 9 Offset Adjust |
| 7 Offset Adjust | 8 Analog Output |

APPLICATIONS INFORMATION

LAYOUT CONSIDERATIONS—Proper attention to layout and decoupling is necessary to obtain specified accuracy and speed performance from MN346 and MN347. The units' two Ground pins (pins 4 and 6) are not connected to each other internally. They should be tied together as close to the unit as possible and both connected to system analog ground, preferably through a large analog ground plane underneath the package. If p.c. card ground lines must be run separately, wide conductor runs should be used with $0.01\mu\text{F}$ ceramic capacitors interconnecting them as close to the package as possible.

Coupling between analog inputs and digital signals should be minimized to avoid noise pick-up. Care should be taken to avoid long runs or analog runs close to digital lines. Input and output signal lines should be kept as short as possible, and if external offset adjustment is used, the potentiometer should be located as close to the unit as possible. If offset adjust is not used, pins 7 and 9 should be left open.

Power supply connections should be short and direct, and all power supplies should be decoupled with high-frequency bypass capacitors to ground. 1 μ F tantalum capacitors in parallel with 0.01 μ F ceramic capacitors are the most effective combination. Single 1 μ F ceramic capacitors can be used if necessary to save board space.

OFFSET ADJUSTMENT—MN346/347's track-mode offset error can be reduced to zero with a 5k Ω potentiometer connected between pins 7 and 9 with its wiper connected to +15V. With the analog signal path grounded, the pot should be adjusted until the output equals zero volts. The pot can also be used to compensate for the effects

of pedestal by performing the adjustment in the hold mode. This adjustment is normally made while continually switching from track to hold and observing the T/H output on a scope. This procedure will eliminate adjustment ambiguities resulting from output droop.

TRACK-HOLD COMMAND—A TTL logic "1" applied to pin 1 will put the MN346/347 into the track (sample) mode. In this mode, the device acts as an inverting unity gain amplifier, and its output will follow (track) its input. A logic "0" applied to pin 1 will put the MN346/347 into the hold mode, and the output will be held constant at the level present when the hold command was given.

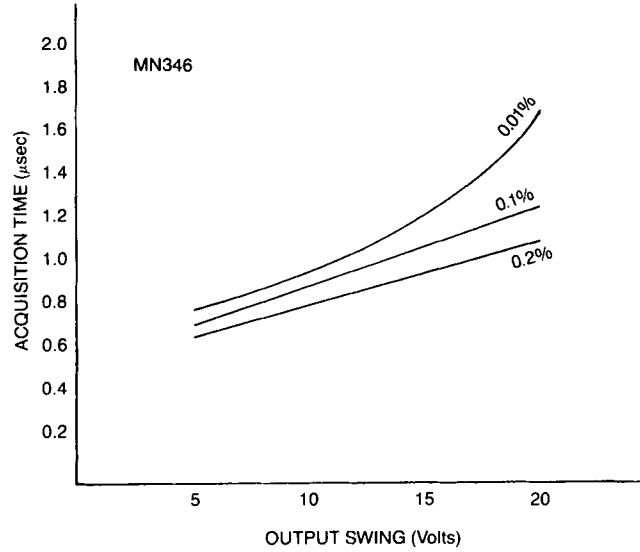
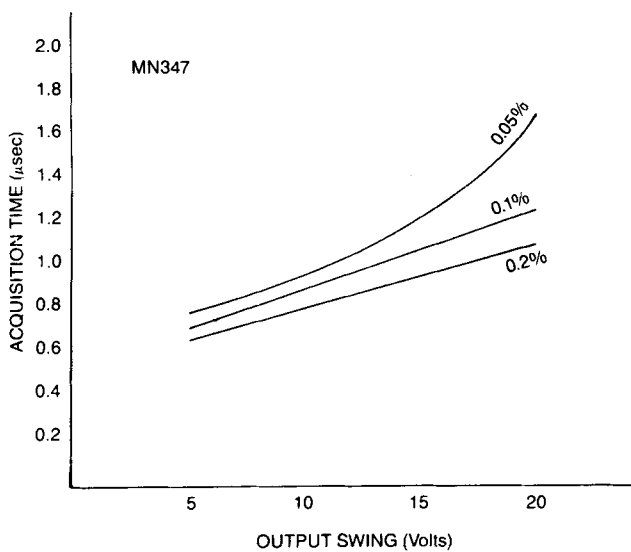

ORDERING INFORMATION

Part Number	Specified Temperature Range	Gain Error (Max)		Offset Error (Max)		Pedestal (Max)		Acquisition Time (2) (10V Step, Max)	Output Droop Rate (3) (Max)	
		+25°C	Temp.	+25°C	Temp.	+25°C	Temp.		+25°C	Temp.
MN346	0°C to +70°C	± 0.02%	± 0.05%	± 3mV	± 20mV	± 4mV	± 20mV	2 μ sec	± 0.5	± 60
MN346H	-55°C to +125°C	± 0.02%	± 0.05%	± 3mV	± 20mV	± 4mV	± 20mV	2 μ sec	± 0.5	± 700
MN346H/B (1)	-55°C to +125°C	± 0.02%	± 0.05%	± 3mV	± 20mV	± 4mV	± 20mV	2 μ sec	± 0.5	± 700
MN347	0°C to +70°C	± 0.05%	± 0.1%	± 5mV	± 20mV	± 8mV	± 20mV	3 μ sec	± 1.5	± 150
MN347H	-55°C to +125°C	± 0.05%	± 0.1%	± 5mV	± 20mV	± 8mV	± 20mV	3 μ sec	± 1.5	± 1500
MN347H/B (1)	-55°C to +125°C	± 0.05%	± 0.1%	± 5mV	± 20mV	± 8mV	± 20mV	3 μ sec	± 1.5	± 1500

Notes:

1. Add "CH" to "H/B" models for 100% screening to MIL-H-38534.
2. For the MN346, acquisition time is specified for a final error band of ±0.01%.
For the MN347, acquisition time is specified for a final error band of ±0.05%.
3. The units for droop are μ V/ μ sec.