

LF198JAN

Monolithic Sample-and-Hold Circuits

General Description

The LF198 is a monolithic sample-and-hold circuit which utilizes BI-FET technology to obtain ultra-high dc accuracy with fast acquisition of signal and low droop rate. Operating as a unity gain follower, dc gain accuracy is 0.002% typical and acquisition time is as low as 6 μ s to 0.01%. A bipolar input stage is used to achieve low offset voltage and wide bandwidth. Input offset adjust is accomplished with a single pin, and does not degrade input offset drift. The wide bandwidth allows the LF198 to be included inside the feedback loop of 1 MHz op amps without having stability problems. Input impedance of $10^{10}\Omega$ allows high source impedances to be used without degrading accuracy.

P-channel junction FET's are combined with bipolar devices in the output amplifier to give droop rates as low as 5 mV/min with a 1 μ F hold capacitor. The JFET's have much lower noise than MOS devices used in previous designs and do not exhibit high temperature instabilities. The overall design guarantees no feed-through from input to output in the hold mode, even for input signals equal to the supply voltages.

Features

- Operates from ± 5 V to ± 18 V supplies
- Less than 10 μ s acquisition time
- TTL, PMOS, CMOS compatible logic input
- 0.5 mV typical hold step at $C_h = 0.01 \mu$ F
- Low input offset
- 0.002% gain accuracy
- Low output noise in hold mode
- Input characteristics do not change during hold mode
- High supply rejection ratio in sample or hold
- Wide bandwidth
- Space Qualified

Logic inputs on the LF198 are fully differential with low input current, allowing direct connection to TTL, PMOS, and CMOS. Differential threshold is 1.4V. The LF198 will operate from ± 5 V to ± 18 V supplies.

Ordering Information

NSC Part Number	JAN Part Number	NSC Package Number	Package Description
JL198BGA	JM38510/12501BGA	H08C	8LD Metal Can
JL198SGA	JM38510/12501SGA	H08C	8LD Metal Can

Connection Diagrams

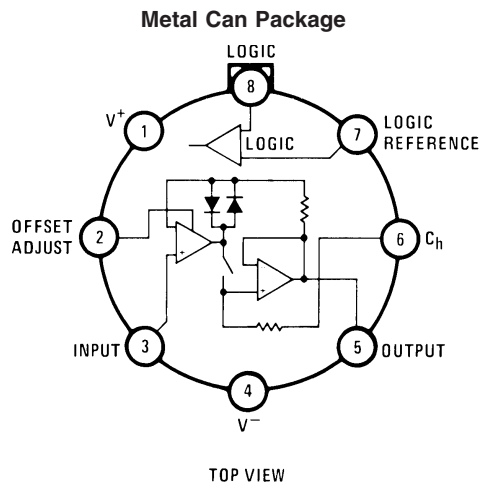

20128114

See NS Package Number H08C

Typical Connection and Performance Curve

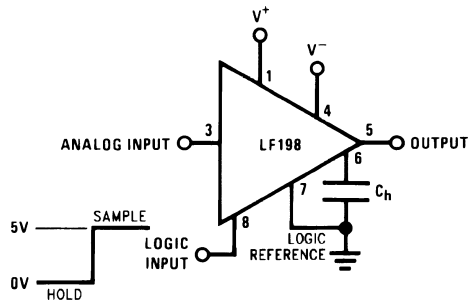

20128132

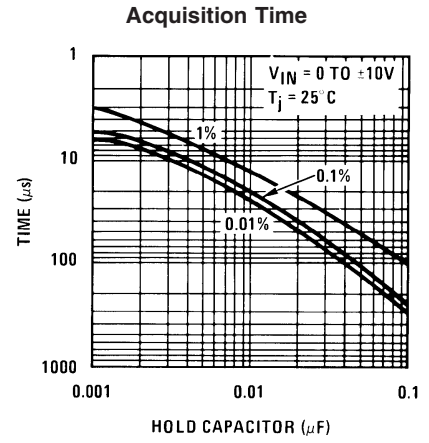

20128116

Functional Diagram

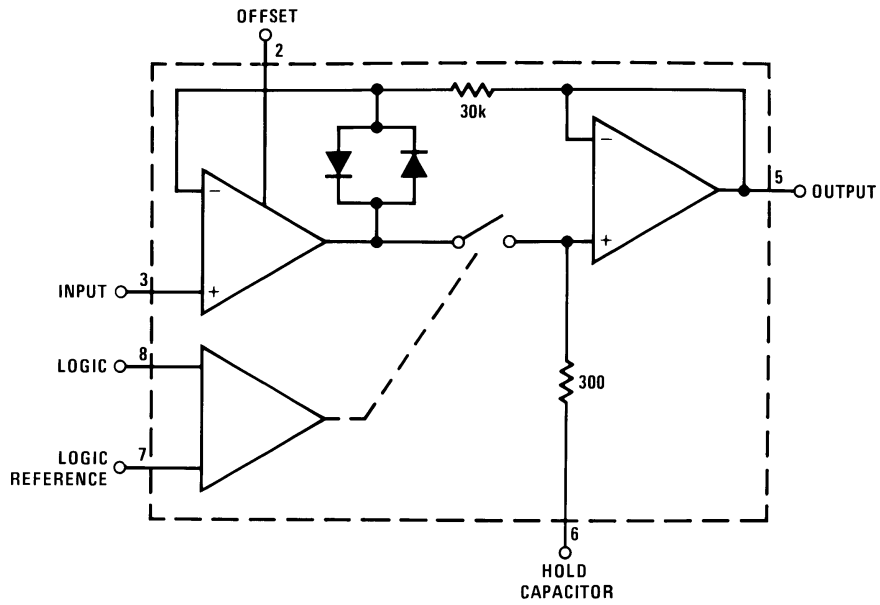

20128101

Absolute Maximum Ratings (Note 1)

Supply Voltage	±18V
Power Dissipation (Package Limitation) (Note 2)	500 mW
Operating Ambient Temperature Range	$-55^{\circ}\text{C} \leq T_A \leq +125^{\circ}\text{C}$
Storage Temperature Range	-65°C to $+150^{\circ}\text{C}$
Maximum Junction Temperature (T_{Jmax})	$+150^{\circ}\text{C}$
Input Voltage	Equal to Supply Voltage
Logic To Logic Reference Differential Voltage (Note 3)	+7V, -30V
Output Short Circuit Duration	Indefinite
Hold Capacitor Short Circuit Duration	10 sec
Lead Temperature (Soldering, 10 sec.)	300°C
Thermal Resistance	
θ_{JA}	
Metal Can (Still Air @ 0.5W)	160°C/W
Metal Can (500 LF/Min Air Flow @ 0.5W)	84°C/W
θ_{JC}	
Metal Can	48°C/W
ESD Tolerance (Note 7)	500V

Quality Conformance Inspection

Mil-Std-883, Method 5005 — Group A

Subgroup	Description	Temperature ($^{\circ}\text{C}$)
1	Static tests at	$+25^{\circ}\text{C}$
2	Static tests at	$+125^{\circ}\text{C}$
3	Static tests at	-55°C
4	Dynamic tests at	$+25^{\circ}\text{C}$
5	Dynamic tests at	$+125^{\circ}\text{C}$
6	Dynamic tests at	-55°C
7	Functional tests at	$+25^{\circ}\text{C}$
8A	Functional tests at	$+125^{\circ}\text{C}$
8B	Functional tests at	-55°C
9	Switching tests at	$+25^{\circ}\text{C}$
10	Switching tests at	$+125^{\circ}\text{C}$
11	Switching tests at	-55°C

Electrical Characteristics

DC Parameters

Symbol	Parameter	Conditions	Notes	Min	Max	Unit	Sub-groups		
V_{IO}	Input Offset Voltage	$+V_{CC} = 3.5V, -V_{CC} = -26.5V,$ $V_{CM} = 11.5V$		-3.0	3.0	mV	1		
				-5.0	5.0	mV	2, 3		
		$+V_{CC} = 26.5V, -V_{CC} = -3.5V,$ $V_{CM} = -11.5V$		-3.0	3.0	mV	1		
				-5.0	5.0	mV	2, 3		
		$+V_{CC} = 15V, -V_{CC} = -15V,$ $V_{CM} = 0V$		-3.0	3.0	mV	1		
				-5.0	5.0	mV	2, 3		
I_{IB}	Input Bias Current	$+V_{CC} = 3.5V, -V_{CC} = -26.5V,$ $V_{CM} = 11.5V$		-1.0	25	nA	1		
				-25	75	nA	2, 3		
		$+V_{CC} = 26.5V, -V_{CC} = -3.5V, V_{CM}$ $= -11.5V$		-1.0	25	nA	1		
				-25	75	nA	2, 3		
		$+V_{CC} = 15V, -V_{CC} = -15V,$ $V_{CM} = 0V$		-1	25	nA	1		
				-25	75	nA	2, 3		
Z_i	Input Impedance	$+V_{CC} = 3.5V$ to $26.6V,$ $-V_{CC} = -26.5V$ to $-3.5V,$ $V_{CM} = 11.5V$ to $-11.5V$		2.0		G Ω	1		
				1.0		G Ω	2, 3		
		$+V_{CC} = 15V, -V_{CC} = -15V,$ $V_{CM} = 0V$		6.0		mV	1, 2, 3		
					-6.0	mV	1, 2, 3		
		PSRR+	Power Supply Rejection Ratio	$-V_{CC} = -18V,$ $+V_{CC} = 18V$ to $12V$		80		dB	1, 2, 3
						80		dB	1, 2, 3
I_{CC}	Supply Current	$+V_{CC} = 15V, -V_{CC} = -15V,$ $V_{CM} = 0V$		1.0	5.5	mA	1,2		
				1.0	6.5	mA	3		
A_E	Gain Error	$+V_{CC} = 3.5V$ to $26.5V,$ $-V_{CC} = -26.5V$ to $-3.5V,$ $V_{CM} = -11.5V$ to $11.5V$		-0.005	0.005	%	1		
				-0.02	0.02	%	2, 3		
		$+V_{CC} = 3V$ to $7V,$ $-V_{CC} = -7V$ to $-3V,$ $V_{CM} = -2V$ to $2V$		-0.02	0.02	%	1		
				-0.04	0.04	%	2, 3		
R_{SC}	Series Charge Resistance	$+V_{CC} = 15V, -V_{CC} = -15V,$ $V_{CM} = 0V$		75	400	Ω	1, 2, 3		
I_{IH} (a)	Logical 1 Input Current	$+V_{CC} = 8.5V, -V_{CC} = -21.5V$		0	10	μA	1, 2, 3		
I_{IH} (b)	Logical 1 Input Current	$+V_{CC} = 8.5V, -V_{CC} = -21.5V$		0	10	μA	1, 2, 3		
I_{IL} (a)	Logical 0 Input Current	$+V_{CC} = 21.5V, -V_{CC} = -8.5V$		-1.0	1.0	μA	1, 2, 3		
I_{IL} (b)	Logical 0 Input Current	$+V_{CC} = 21.5V, -V_{CC} = -8.5V$		-1.0	1.0	μA	1, 2, 3		
I_{OS+}	Output Short Circuit Current	$+V_{CC} = 15V, -V_{CC} = -15V,$ $V_{CM} = 0V$		-25		mA	1, 2, 3		

Electrical Characteristics (Continued)**DC Parameters** (Continued)

Symbol	Parameter	Conditions	Notes	Min	Max	Unit	Sub-groups
I_{OS^-}	Output Short Circuit Current	$+V_{CC} = 15V, -V_{CC} = -15V,$ $V_{CM} = 0V$			25	mA	1, 2, 3
I_{CH^+}	Hold Capacitor Charge Current	$+V_{CC} = 15V, -V_{CC} = -15V,$ $V_{CM} = 0V$			-3.0	mA	1
					-2.0	mA	2, 3
I_{CH^-}	Hold Capacitor Charge Current	$+V_{CC} = 15V, -V_{CC} = -15V,$ $V_{CM} = 0V$		3.0		mA	1
				2.0		mA	2, 3
$V_{TH(H)}$	Differential Logic Threshold	$+V_{CC} = 15V, -V_{CC} = -15V,$ $V_{CM} = 0V$ Logic = 2.0V, Logic Ref = 2.0V		1.0		mA	1, 2, 3
$V_{TH(L)}$	Differential Logic Threshold	$+V_{CC} = 15V, -V_{CC} = -15V,$ $V_{CM} = 0V$ Logic = 0.8V, Logic Ref = 2.0V		-10	10	μA	1, 2, 3
I_{HL^+}	Hold Mode Leakage Current	$+V_{CC} = 3.5V, -V_{CC} = -26.5V,$ $V_{CM} = -11.5V$	(Note 5)	-0.100	0.100	nA	1
				-50	50	nA	2
I_{HL^-}	Hold Mode Leakage Current	$+V_{CC} = 26.5V, -V_{CC} = -3.5V,$ $V_{CM} = 11.5V$	(Note 5)	-0.100	0.100	nA	1
				-50	50	nA	2
Z_O	Output Impedance	$+V_{CC} = 15V, -V_{CC} = -15V,$ $V_{CM} = 0V$			2.0	Ω	1, 2, 3
V_{HS}	(HOLD) Step Voltage	$+V_{CC} = 3.5V, -V_{CC} = -26.5V,$ $V_{CM} = 11.5V$	(Note 4)	-2.0	2.0	mV	1
				-5.0	5.0	mV	2, 3
		$+V_{CC} = 26.5V, -V_{CC} = -3.5V,$ $V_{CM} = -11.5V$	(Note 4)	-2.0	2.0	mV	1
				-5.0	5.0	mV	2, 3
F_{RR}	Feedthrough Rejection Ratio	$+V_{CC} = 15V, -V_{CC} = -15V,$ $V_{CM} = 0V, V_I = 0V \text{ to } 11.5V$		86		dB	1
				80		dB	2, 3
		$+V_{CC} = 15V, -V_{CC} = -15V,$ $V_{CM} = 0V, V_I = 11.5V \text{ to } 0V$		86		dB	1
				80		dB	2, 3
		$+V_{CC} = 15V, -V_{CC} = -15V,$ $V_{CM} = 0V, V_I = 0V \text{ to } -11.5V$		86		dB	1
				80		dB	2, 3
$+V_{CC} = 15V, -V_{CC} = -15V,$ $V_{CM} = 0V, V_I = -11.5V \text{ to } 0V$		86		dB	1		
		80		dB	2, 3		

AC/DC Parameters

Symbol	Parameter	Conditions	Notes	Min	Max	Unit	Sub-groups
$\Delta V_{IO} / \Delta T$	Input Offset Voltage Temp Sensitivity			-20	20	$\mu V/^{\circ}C$	8A, 8B
T_{AQ}	Aquisition Time	$+V_{CC} = 15V, -V_{CC} = -15V$			25	μS	7
T_{AP}	Aperture Time	$+V_{CC} = 15V, -V_{CC} = -15V$			300	nS	7
T_S	Settling Time	$+V_{CC} = 15V, -V_{CC} = -15V$			1.5	μS	7
$F_{RR AC}$	Feedthrough Rejection Ratio	$+V_{CC} = 15V, -V_{CC} = -15V,$ $V_I = 20V_{pp}$		86		dB	7
TR_{TS}	Transient Response (settling time)	$+V_{CC} = 3.5V, -V_{CC} = -26.5V,$ $V_I = 100mV \text{ pulse}$			2.5	μS	7
		$+V_{CC} = 26.5V, -V_{CC} = -3.5V,$ $V_I = 100mV \text{ pulse}$			2.5	μS	7

AC/DC Parameters (Continued)

Symbol	Parameter	Conditions	Notes	Min	Max	Unit	Sub-groups
TR _{OS}	Transient Response (overshoot)	+V _{CC} = 3.5V, -V _{CC} = -26.5V, V _I = 100mV pulse			40	%	7
		+V _{CC} = 26.5V, -V _{CC} = -3.5V, V _I = 100mV pulse			40	%	7
en _H	Noise	+V _{CC} = 15V, -V _{CC} = -15V			10	mV _{RMS}	7
en _S	Noise	+V _{CC} = 15V, -V _{CC} = -15V			10	mV _{RMS}	7

DC Parameters: Drift Values

Delta calculations performed on S-Level devices at group B, subgroup 5 ONLY.

Symbol	Parameters	Conditions	Notes	Min	Max	Unit	Sub-groups
V _{IO}	Input Offset Voltage	+V _{CC} = 15V, -V _{CC} = -15V, V _{CM} = 0V		-0.5	0.5	mV	1
I _{IB}	Input Bias Current	+V _{CC} = 15V, -V _{CC} = -15V, V _{CM} = 0V		-2.5	2.5	nA	1

Note 1: "Absolute Maximum Ratings" indicate limits beyond which damage to the device may occur. Operating Ratings indicate conditions for which the device is functional, but do not guarantee specific performance limits. For guaranteed specifications and test conditions, see the Electrical Characteristics. The guaranteed specifications apply only for the test conditions listed. Some performance characteristics may degrade when the device is not operated under the listed test conditions

Note 2: The maximum power dissipation must be derated at elevated temperatures and is dictated by T_{JMAX}, θ_{JA}, and the ambient temperature, T_A. The maximum allowable power dissipation at any temperature is P_D = (T_{JMAX} - T_A)/θ_{JA}, or the number given in the Absolute Maximum Ratings, whichever is lower. .

Note 3: Although the differential voltage may not exceed the limits given, the common-mode voltage on the logic pins may be equal to the supply voltages without causing damage to the circuit. For proper logic operation, however, one of the logic pins must always be at least 2V below the positive supply and 3V above the negative supply.

Note 4: Hold step is sensitive to stray capacitive coupling between input logic signals and the hold capacitor. 1 pF, for instance, will create an additional 0.5 mV step with a 5V logic swing and a 0.01µF hold capacitor. Magnitude of the hold step is inversely proportional to hold capacitor value.

Note 5: Leakage current is measured at a junction temperature of 25°C. The effects of junction temperature rise due to power dissipation or elevated ambient can be calculated by doubling the 25°C value for each 11°C increase in chip temperature. Leakage is guaranteed over full input signal range.

Note 6: See Definition of Terms

Note 7: Human body model, 100pF discharged through 1.5KΩ

Typical Performance Characteristics

Aperture Time
(Note 6)

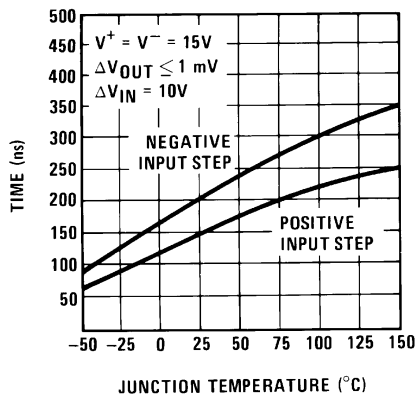

20128117

Dielectric Absorption
Error in Hold Capacitor

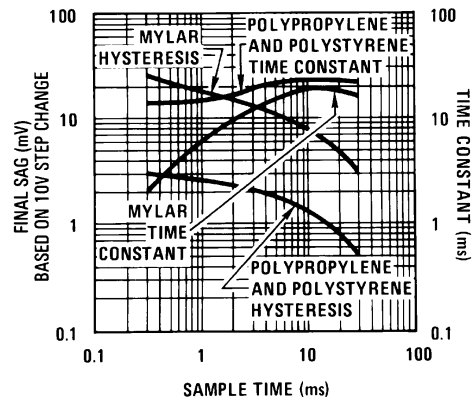

20128118

Typical Performance Characteristics (Continued)

Dynamic Sampling Error
(Note 6)

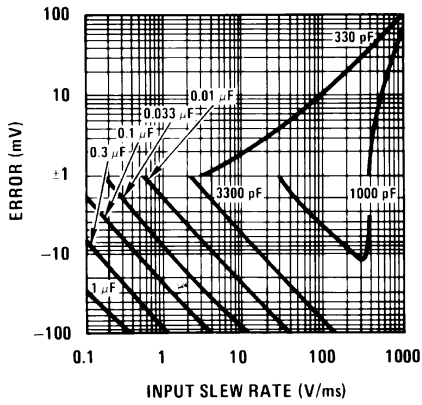

20128119

Output Droop Rate

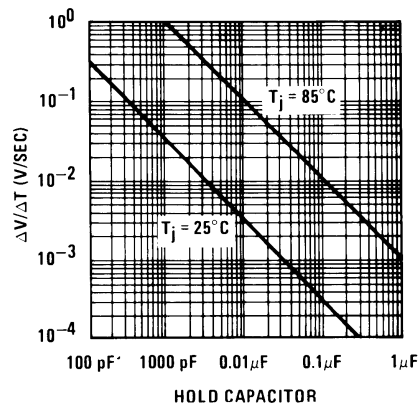

20128120

Hold Step
(Note 6)

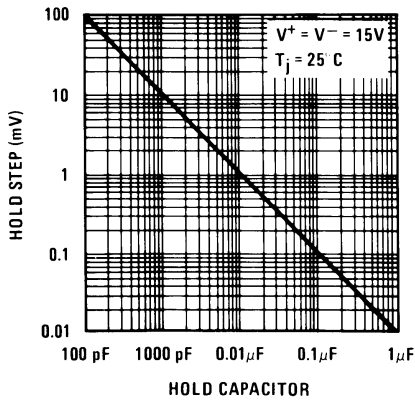

20128121

"Hold" Settling Time
(Note 6)

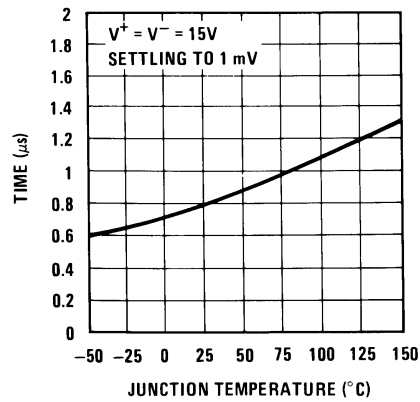

20128122

Leakage Current into Hold Capacitor

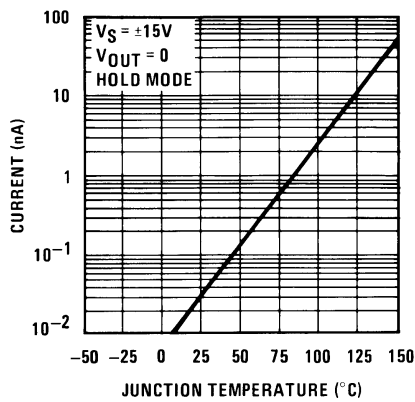

20128123

Phase and Gain (Input to Output, Small Signal)

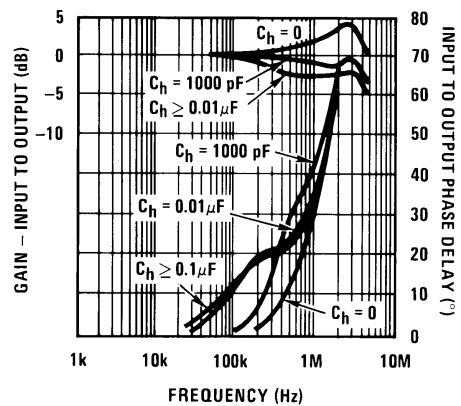

20128124

Typical Performance Characteristics (Continued)

Gain Error

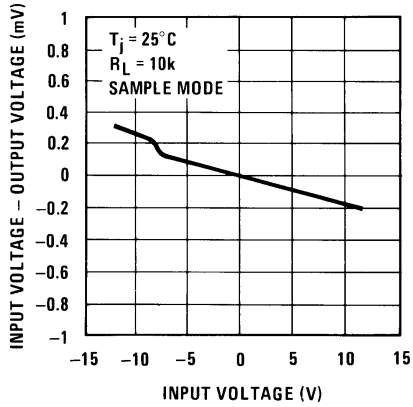

20128125

Power Supply Rejection

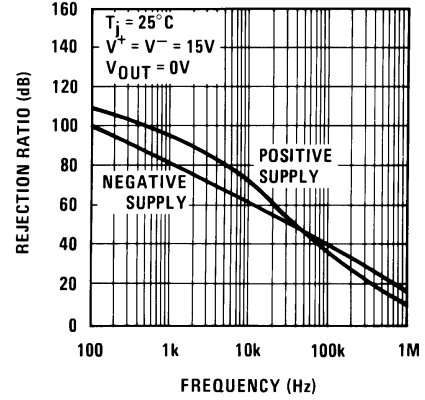

20128126

Output Short Circuit Current

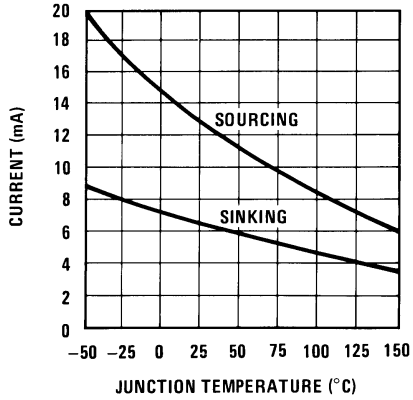

20128127

Output Noise

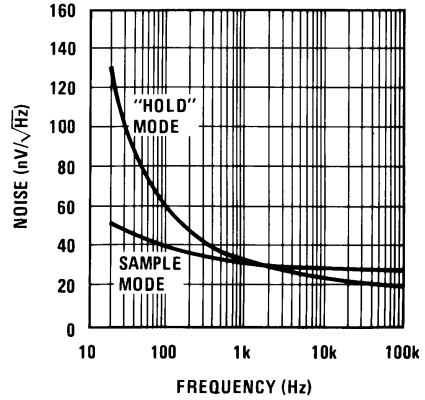

20128128

Note 8: See Definition

Input Bias Current

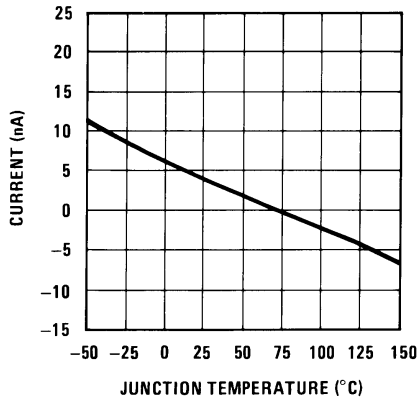

20128129

Feedthrough Rejection Ratio (Hold Mode)

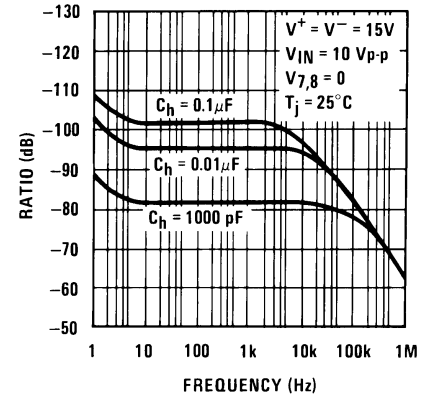

20128130

Typical Performance Characteristics (Continued)

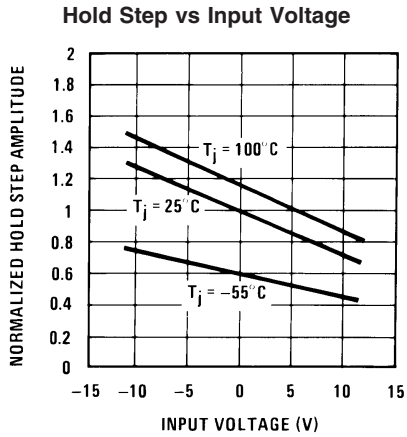

20128131

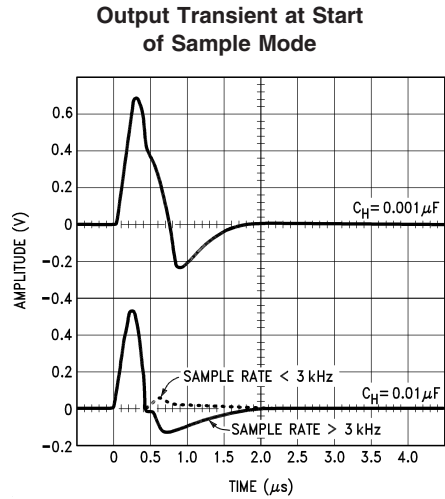

20128112

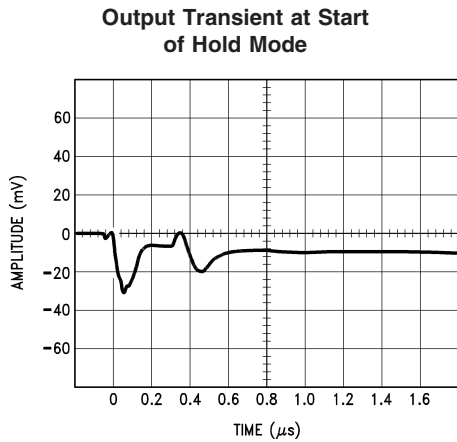

20128113

Logic Input Configurations

TTL & CMOS

$3V \leq V_{LOGIC} (Hi State) \leq 7V$

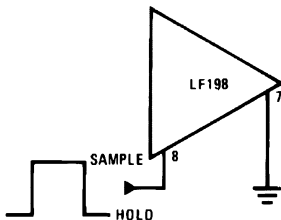

20128133

Threshold = 1.4V

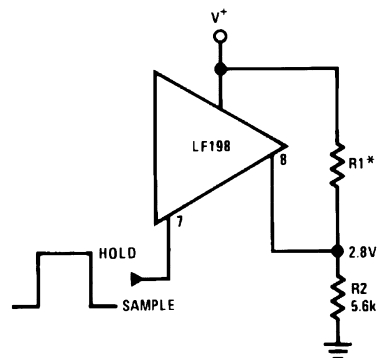

20128134

Threshold = 1.4V*Select for 2.8V at pin 8

Logic Input Configurations (Continued)

CMOS

$$7V \leq V_{\text{LOGIC}} (\text{Hi State}) \leq 15V$$

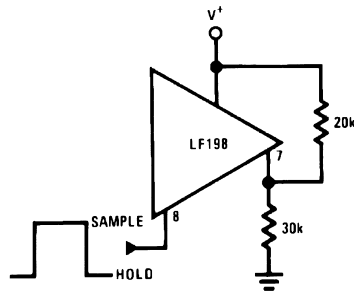

20128135

$$\text{Threshold} = 0.6 (V^+) + 1.4V$$

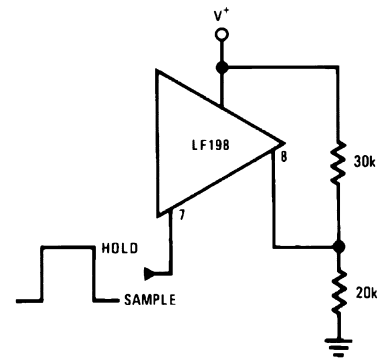

20128136

$$\text{Threshold} = 0.6 (V^+) - 1.4V$$

Op Amp Drive

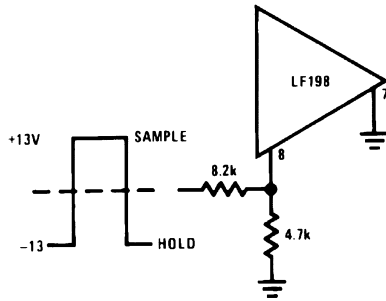

20128137

$$\text{Threshold} \approx +4V$$

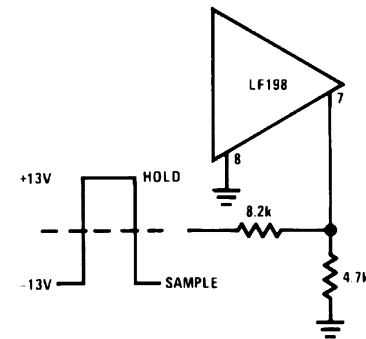

20128138

$$\text{Threshold} = -4V$$

Application Hints

HOLD CAPACITOR

Hold step, acquisition time, and droop rate are the major trade-offs in the selection of a hold capacitor value. Size and cost may also become important for larger values. Use of the curves included with this data sheet should be helpful in selecting a reasonable value of capacitance. Keep in mind that for fast repetition rates or tracking fast signals, the capacitor drive currents may cause a significant temperature rise in the LF198.

A significant source of error in an accurate sample and hold circuit is dielectric absorption in the hold capacitor. A mylar cap, for instance, may "sag back" up to 0.2% after a quick change in voltage. A long sample time is required before the circuit can be put back into the hold mode with this type of capacitor. Dielectrics with very low hysteresis are polystyrene, polypropylene, and Teflon. Other types such as mica and polycarbonate are not nearly as good. The advantage of polypropylene over polystyrene is that it extends the maximum ambient temperature from 85°C to 100°C. Most ceramic capacitors are unusable with > 1% hysteresis. Ceramic "NPO" or "COG" capacitors are now available for 125°C operation and also have low dielectric absorption. For more exact data, see the curve *Dielectric Absorption Error*.

The hysteresis numbers on the curve are final values, taken after full relaxation. The hysteresis error can be significantly reduced if the output of the LF198 is digitized quickly after the hold mode is initiated. The hysteresis relaxation time constant in polypropylene, for instance, is 10—50 ms. If A-to-D conversion can be made within 1 ms, hysteresis error will be reduced by a factor of ten.

DC AND AC ZEROING

DC zeroing is accomplished by connecting the offset adjust pin to the wiper of a 1 kΩ potentiometer which has one end tied to V+ and the other end tied through a resistor to ground. The resistor should be selected to give ≈0.6 mA through the 1k potentiometer.

AC zeroing (hold step zeroing) can be obtained by adding an inverter with the adjustment pot tied input to output. A 10 pF capacitor from the wiper to the hold capacitor will give ±4 mV hold step adjustment with a 0.01 μF hold capacitor and 5V logic supply. For larger logic swings, a smaller capacitor (< 10 pF) may be used.

LOGIC RISE TIME

For proper operation, logic signals into the LF198 must have a minimum dV/dt of 1.0 V/μs. Slower signals will cause excessive hold step. If a R/C network is used in front of the

Application Hints (Continued)

logic input for signal delay, calculate the slope of the waveform at the threshold point to ensure that it is at least $1.0 \text{ V}/\mu\text{s}$.

SAMPLING DYNAMIC SIGNALS

Sample error to moving input signals probably causes more confusion among sample-and-hold users than any other parameter. The primary reason for this is that many users make the assumption that the sample and hold amplifier is truly locked on to the input signal while in the sample mode. In actuality, there are finite phase delays through the circuit creating an input-output differential for fast moving signals. In addition, although the output may have settled, the hold capacitor has an additional lag due to the 300Ω series resistor on the chip. This means that at the moment the "hold" command arrives, the hold capacitor voltage may be somewhat different than the actual analog input. The effect of these delays is opposite to the effect created by delays in the logic which switches the circuit from sample to hold. For example, consider an analog input of 20 Vp-p at 10 kHz . Maximum dV/dt is $0.6 \text{ V}/\mu\text{s}$. With no analog phase delay and 100 ns logic delay, one could expect up to $(0.1 \mu\text{s})(0.6 \text{ V}/\mu\text{s}) = 60 \text{ mV}$ error if the "hold" signal arrived near maximum dV/dt of the input. A positive-going input would give a $+60 \text{ mV}$ error. Now assume a 1 MHz (3 dB) bandwidth for the overall analog loop. This generates a phase delay of 160 ns . If the hold capacitor sees this exact delay, then error due to analog delay will be $(0.16 \mu\text{s})(0.6 \text{ V}/\mu\text{s}) = -96 \text{ mV}$. Total output error is $+60 \text{ mV}$ (digital) -96 mV (analog) for a total of -36 mV . To add to the confusion, analog delay is proportioned to hold capacitor value while digital delay remains constant. A family of curves (dynamic sampling error) is included to help estimate errors.

A curve labeled *Aperture Time* has been included for sampling conditions where the input is steady during the sampling period, but may experience a sudden change nearly coincident with the "hold" command. This curve is based on a 1 mV error fed into the output.

A second curve, *Hold Settling Time* indicates the time required for the output to settle to 1 mV after the "hold" command.

DIGITAL FEEDTHROUGH

Fast rise time logic signals can cause hold errors by feeding externally into the analog input at the same time the amplifier is put into the hold mode. To minimize this problem, board layout should keep logic lines as far as possible from the analog input and the C_h pin. Grounded guarding traces may also be used around the input line, especially if it is driven from a high impedance source. Reducing high amplitude logic signals to 2.5V will also help.

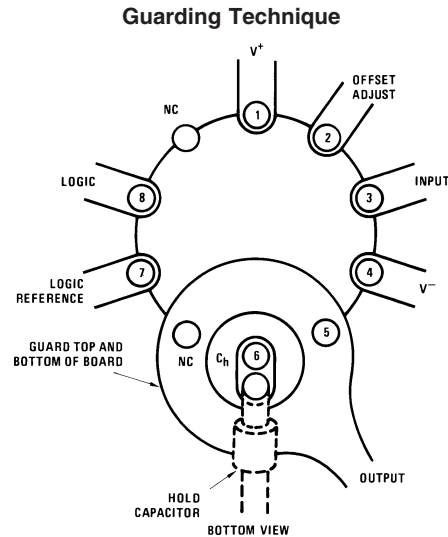

20128105

Use 10-pin layout. Guard around C_h is tied to output.

Typical Applications

X1000 Sample & Hold

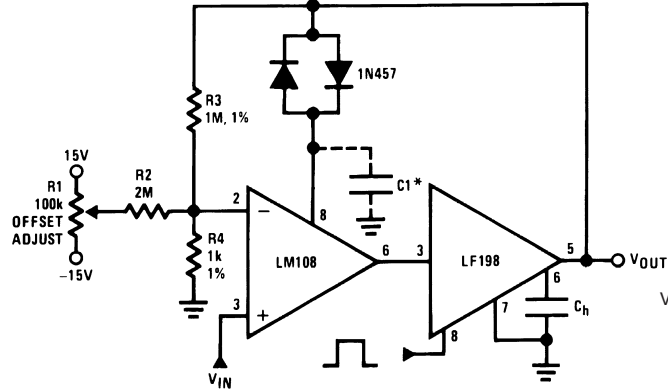

20128139

*For lower gains, the LM108 must be frequency compensated

$$\text{Use } \approx \frac{100}{A_v} \text{ pF from comp 2 to ground}$$

Sample and Difference Circuit
(Output Follows Input in Hold Mode)

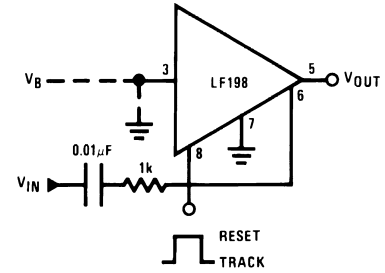

20128140

$$V_{OUT} = V_B + \Delta V_{IN}(\text{HOLD MODE})$$

Ramp Generator with Variable Reset Level

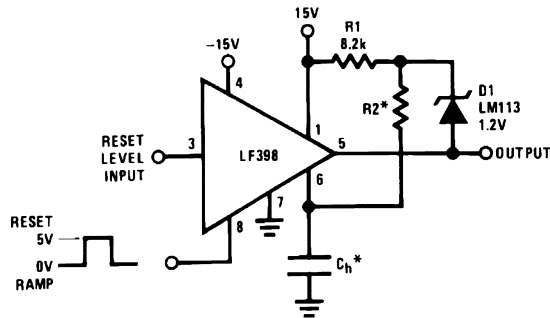

20128142

$$\text{*Select for ramp rate } \frac{\Delta V}{\Delta T} = \frac{1.2V}{(R2)(C_h)}$$

Integrator with Programmable Reset Level

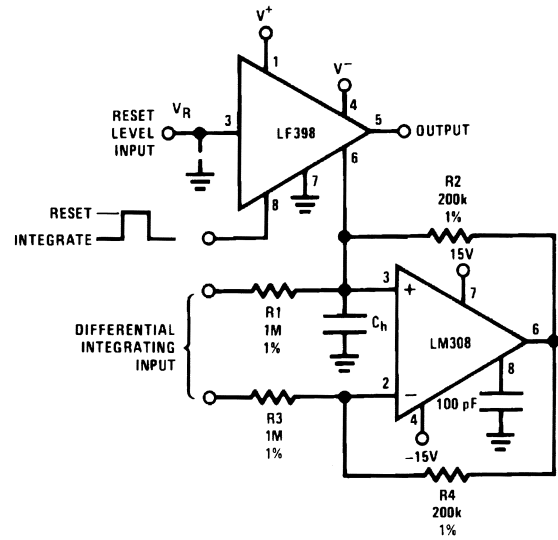

20128143

$$V_{OUT}(\text{Hold Mode}) = \left[\frac{1}{(R1)(C_h)} \int_0^t V_{IN} dt \right] + [V_R]$$

Typical Applications (Continued)

Output Holds at Average of Sampled Input

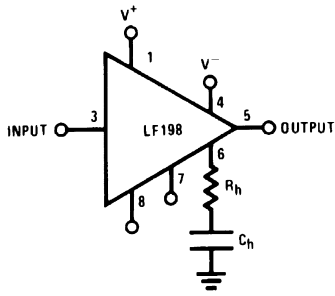

20128146

$$\text{Select } (R_h) (C_h) \geq \frac{1}{2\pi f_{IN} (\text{Min})}$$

Increased Slew Current

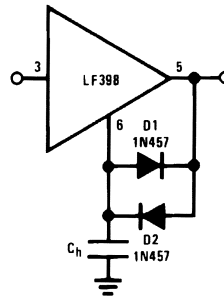

20128147

Reset Stabilized Amplifier (Gain of 1000)

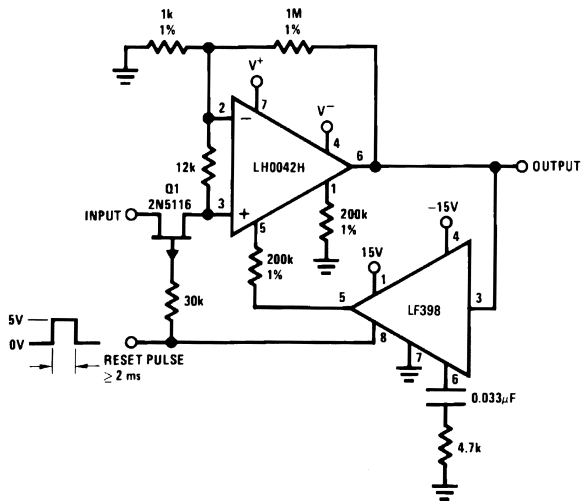

20128149

$$V_{OS} \leq 20\mu\text{V (No trim)}$$

$$Z_{IN} \approx 1\text{ M}\Omega$$

$$\frac{\Delta V_{OS}}{\Delta t} \approx 30\mu\text{V/sec}$$

$$\frac{\Delta V_{OS}}{\Delta T} \approx 0.1\mu\text{V}/^\circ\text{C}$$

Fast Acquisition, Low Droop Sample & Hold

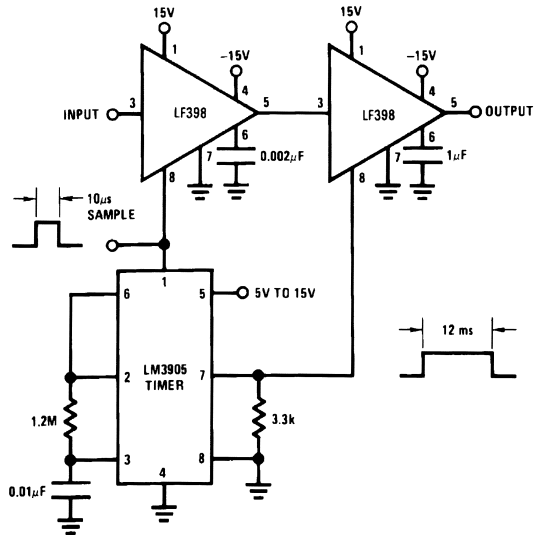

20128150

Typical Applications (Continued)

Synchronous Correlator for Recovering Signals Below Noise Level

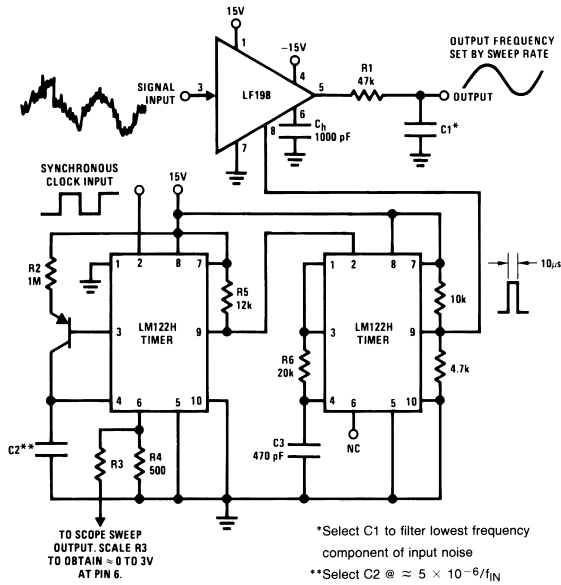

20128152

	A	B
Gain	$1 \pm 0.02\%$	$1 \pm 0.2\%$
Z_{IN}	$10^{10}\Omega$	47 k Ω
BW	≈ 1 MHz	≈ 400 kHz
Crosstalk @ 1 kHz	-90 dB	-90 dB
Offset	≤ 6 mV	≤ 75 mV

2-Channel Switch

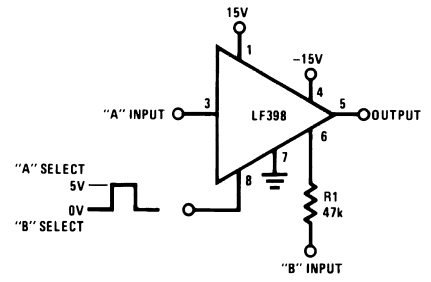

20128153

DC & AC Zeroing

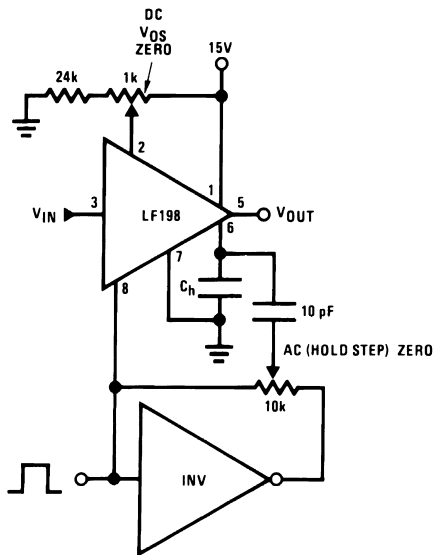

20128159

Staircase Generator

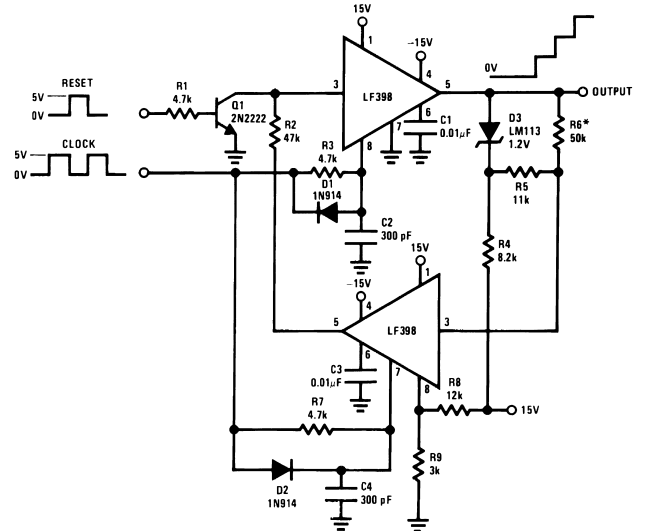

*Select for step height
50k \rightarrow \approx 1V Step

20128155

Typical Applications (Continued)

Differential Hold

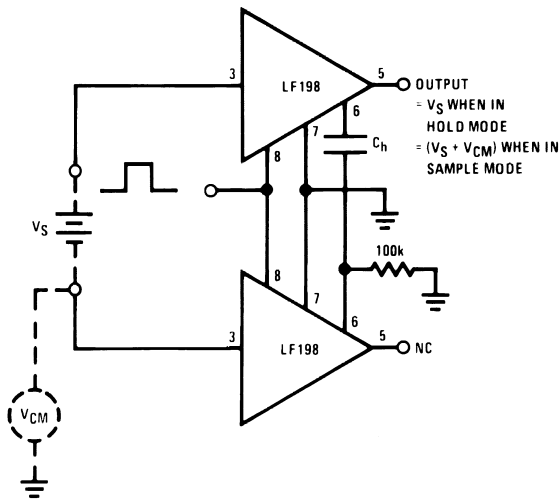

20128157

Capacitor Hysteresis Compensation

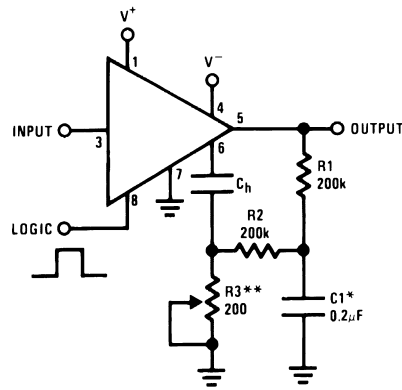

20128156

*Select for time constant $C1 = \frac{T}{100k}$

**Adjust for amplitude

Definition of Terms

Hold Step: The voltage step at the output of the sample and hold when switching from sample mode to hold mode with a steady (dc) analog input voltage. Logic swing is 5V.

Acquisition Time: The time required to acquire a new analog input voltage with an output step of 10V. Note that acquisition time is not just the time required for the output to settle, but also includes the time required for all internal nodes to settle so that the output assumes the proper value when switched to the hold mode.

Gain Error: The ratio of output voltage swing to input voltage swing in the sample mode expressed as a per cent difference.

Hold Settling Time: The time required for the output to settle within 1 mV of final value after the "hold" logic command.

Dynamic Sampling Error: The error introduced into the held output due to a changing analog input at the time the hold command is given. Error is expressed in mV with a given hold capacitor value and input slew rate. Note that this error term occurs even for long sample times.

Aperture Time: The delay required between "Hold" command and an input analog transition, so that the transition does not affect the held output.

Revision History Section

Date Released	Revision	Section	Originator	Changes
02/25/05	A	New release, Corporate format	L. Lytle	1 MDS converted to corp. datasheet format. MJLF198-X Rev 2B0 MDS to be archived.

Physical Dimensions inches (millimeters) unless otherwise noted

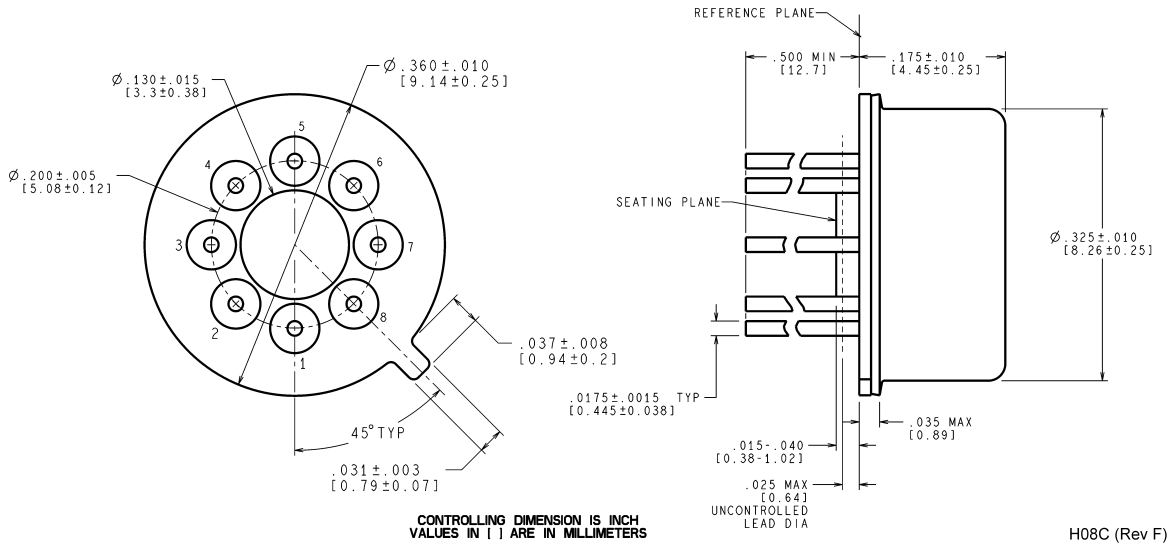

**Metal Can Package (H)
NS Package Number H08C**

H08C (Rev F)

National does not assume any responsibility for use of any circuitry described, no circuit patent licenses are implied and National reserves the right at any time without notice to change said circuitry and specifications.

For the most current product information visit us at www.national.com.

LIFE SUPPORT POLICY

NATIONAL'S PRODUCTS ARE NOT AUTHORIZED FOR USE AS CRITICAL COMPONENTS IN LIFE SUPPORT DEVICES OR SYSTEMS WITHOUT THE EXPRESS WRITTEN APPROVAL OF THE PRESIDENT AND GENERAL COUNSEL OF NATIONAL SEMICONDUCTOR CORPORATION. As used herein:

1. Life support devices or systems are devices or systems which, (a) are intended for surgical implant into the body, or (b) support or sustain life, and whose failure to perform when properly used in accordance with instructions for use provided in the labeling, can be reasonably expected to result in a significant injury to the user.
2. A critical component is any component of a life support device or system whose failure to perform can be reasonably expected to cause the failure of the life support device or system, or to affect its safety or effectiveness.

BANNED SUBSTANCE COMPLIANCE

National Semiconductor manufactures products and uses packing materials that meet the provisions of the Customer Products Stewardship Specification (CSP-9-111C2) and the Banned Substances and Materials of Interest Specification (CSP-9-111S2) and contain no "Banned Substances" as defined in CSP-9-111S2.

National Semiconductor
Americas Customer Support Center
Email: new.feedback@nsc.com
Tel: 1-800-272-9959

National Semiconductor
Europe Customer Support Center
Fax: +49 (0) 180-530 85 86
Email: europe.support@nsc.com
Deutsch Tel: +49 (0) 69 9508 6208
English Tel: +44 (0) 870 24 0 2171
Français Tel: +33 (0) 1 41 91 8790

National Semiconductor
Asia Pacific Customer Support Center
Email: ap.support@nsc.com

National Semiconductor
Japan Customer Support Center
Fax: 81-3-5639-7507
Email: jpn.feedback@nsc.com
Tel: 81-3-5639-7560

www.national.com