

LM4752

Stereo 11W Audio Power Amplifier

General Description

The LM4752 is a stereo audio amplifier capable of delivering 11W per channel of continuous average output power to a 4Ω load, or 7W per channel into 8Ω using a single 24V supply at 10% THD+N.

The LM4752 is specifically designed for single supply operation and a low external component count. The gain and bias resistors are integrated on chip, resulting in a 11W stereo amplifier in a compact 7 pin TO220 package. High output power levels at both 20V and 24V supplies and low external component count offer high value for compact stereo and TV applications. A simple mute function can be implemented with the addition of a few external components.

Key Specifications

- Output power at 10% THD+N with 1kHz into 4Ω at $V_{CC} = 24V$: 11W (typ)
- Output power at 10% THD+N with 1kHz into 8Ω at $V_{CC} = 24V$: 7W (typ)
- Closed loop gain: 34dB (typ)
- P_O at 10% THD+N @ 1 kHz into 4Ω single-ended TO-263 package at $V_{CC} = 12V$: 2.5W (typ)

- P_O at 10% THD+N @ 1kHz into 8Ω bridged TO-263 package at $V_{CC} = 12V$: 5W (typ)

Features

- Drives 4Ω and 8Ω loads
- Internal gain resistors ($A_V = 34$ dB)
- Minimum external component requirement
- Single supply operation
- Internal current limiting
- Internal thermal protection
- Compact 7-lead TO-220 package
- Low cost-per-watt
- Wide supply range 9V - 40V

Applications

- Compact stereos
- Stereo TVs
- Mini component stereos
- Multimedia speakers

Typical Application

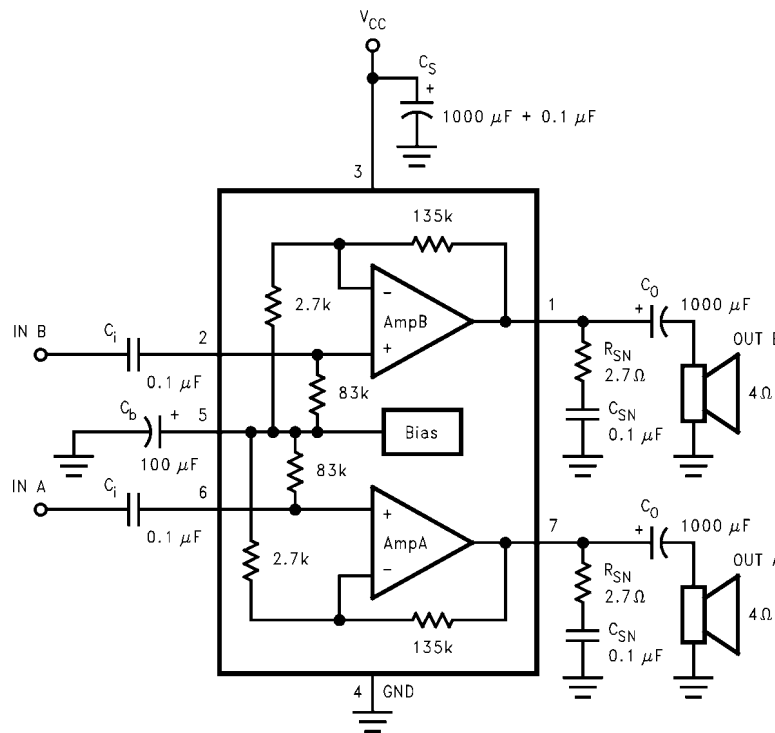
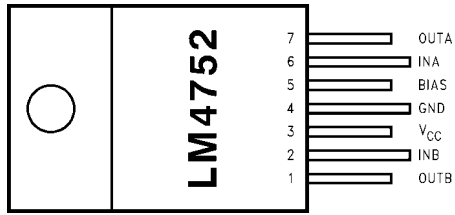

FIGURE 1. Typical Audio Amplifier Application Circuit

Connection Diagrams

Plastic Package



10003902

Package Description
Top View
Order Number LM4752T
Package Number TA07B

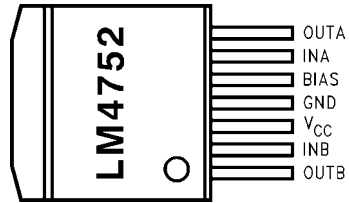

10003950

Package Description
Top View
Order Number LM4752TS
Package Number TS07B

Absolute Maximum Ratings (Note 2)

If Military/Aerospace specified devices are required, please contact the National Semiconductor Sales Office/Distributors for availability and specifications.

Supply Voltage	40V
Input Voltage	±0.7V
Input Voltage at Output Pins (Note 8)	GND – 0.4V
Output Current	Internally Limited
Power Dissipation (Note 3)	62.5W
ESD Susceptibility (Note 4)	2 kV
Junction Temperature	150°C

Soldering Information

T Package (10 sec)

250°C

Storage Temperature

–40°C to 150°C

Operating Ratings

Temperature Range

$$T_{\text{MIN}} \leq T_A \leq T_{\text{MAX}}$$

$$-40^\circ\text{C} \leq T_A \leq +85^\circ\text{C}$$

Supply Voltage

9V to 32V

 θ_{JC}

2°C/W

 θ_{JA}

79°C/W

Electrical Characteristics

The following specifications apply to each channel with $V_{\text{CC}} = 24\text{V}$, $T_A = 25^\circ\text{C}$ unless otherwise specified.

Symbol	Parameter	Conditions	LM4752		Units (Limits)
			Typical (Note 5)	Limit (Note 6)	
I_{total}	Total Quiescent Power Supply Current	$V_{\text{INAC}} = 0\text{V}$, $V_o = 0\text{V}$, $R_L = \infty$	10.5	20 7	mA(max) mA(min)
P_o	Output Power (Continuous Average per Channel)	$f = 1\text{ kHz}$, THD+N = 10%, $R_L = 8\Omega$	7	10	W
		$f = 1\text{ kHz}$, THD+N = 10%, $R_L = 4\Omega$			W(min)
		$V_{\text{CC}} = 20\text{V}$, $R_L = 8\Omega$	4	W	
		$V_{\text{CC}} = 20\text{V}$, $R_L = 4\Omega$	7	W	
		$f = 1\text{ kHz}$, THD+N = 10%, $R_L = 4\Omega$ $V_S = 12\text{V}$, TO-263 Pkg.	2.5	W	
THD+N	Total Harmonic Distortion plus Noise	$f = 1\text{ kHz}$, $P_o = 1\text{ W/ch}$, $R_L = 8\Omega$	0.08		%
V_{OSW}	Output Swing	$R_L = 8\Omega$, $V_{\text{CC}} = 20\text{V}$	15		V
		$R_L = 4\Omega$, $V_{\text{CC}} = 20\text{V}$	14		V
X_{talk}	Channel Separation	See Figure 1 $f = 1\text{ kHz}$, $V_o = 4\text{ Vrms}$, $R_L = 8\Omega$	55		dB
PSRR	Power Supply Rejection Ratio	See Figure 1 $V_{\text{CC}} = 22\text{V}$ to 26V , $R_L = 8\Omega$	50		dB
V_{ODV}	Differential DC Output Offset Voltage	$V_{\text{INAC}} = 0\text{V}$	0.09	0.4	V(max)
SR	Slew Rate		2		V/ μs
R_{IN}	Input Impedance		83		k Ω
PBW	Power Bandwidth	3 dB BW at $P_o = 2.5\text{W}$, $R_L = 8\Omega$	65		kHz
A_{VCL}	Closed Loop Gain (Internally Set)	$R_L = 8\Omega$	34	33	dB(min)
				35	dB(max)
e_{in}	Noise	IHF-A Weighting Filter, $R_L = 8\Omega$ Output Referred	0.2		mVrms
I_o	Output Short Circuit Current Limit	$V_{\text{IN}} = 0.5\text{V}$, $R_L = 2\Omega$		2	A(min)

Note 1: All voltages are measured with respect to the GND pin (4), unless otherwise specified.

Note 2: *Absolute Maximum Ratings* indicate limits beyond which damage to the device may occur. *Operating Ratings* indicate conditions for which the device is functional, but do not guarantee specific performance limits. *Electrical Characteristics* state DC and AC electrical specifications under particular test conditions which guarantee specific performance limits. This assumes that the device is within the Operating Ratings. Specifications are not guaranteed for parameters where no limit is given, however, the typical value is a good indication of device performance.

Note 3: For operating at case temperatures above 25°C, the device must be derated based on a 150°C maximum junction temperature and a thermal resistance of $\theta_{\text{JC}} = 2^\circ\text{C/W}$ (junction to case). Refer to the section Determining the Maximum Power Dissipation in the **Application Information** section for more information.

Note 4: Human body model, 100 pF discharged through a 1.5 k Ω resistor.

Note 5: Typicals are measured at 25°C and represent the parametric norm.

Note 6: Limits are guarantees that all parts are tested in production to meet the stated values.

Note 7: The TO-263 Package is not recommended for $V_S > 16\text{V}$ due to impractical heatsinking limitations.

Note 8: The outputs of the LM4752 cannot be driven externally in any mode with a voltage lower than -0.4V below GND or permanent damage to the LM4752 will result.

Test Circuit

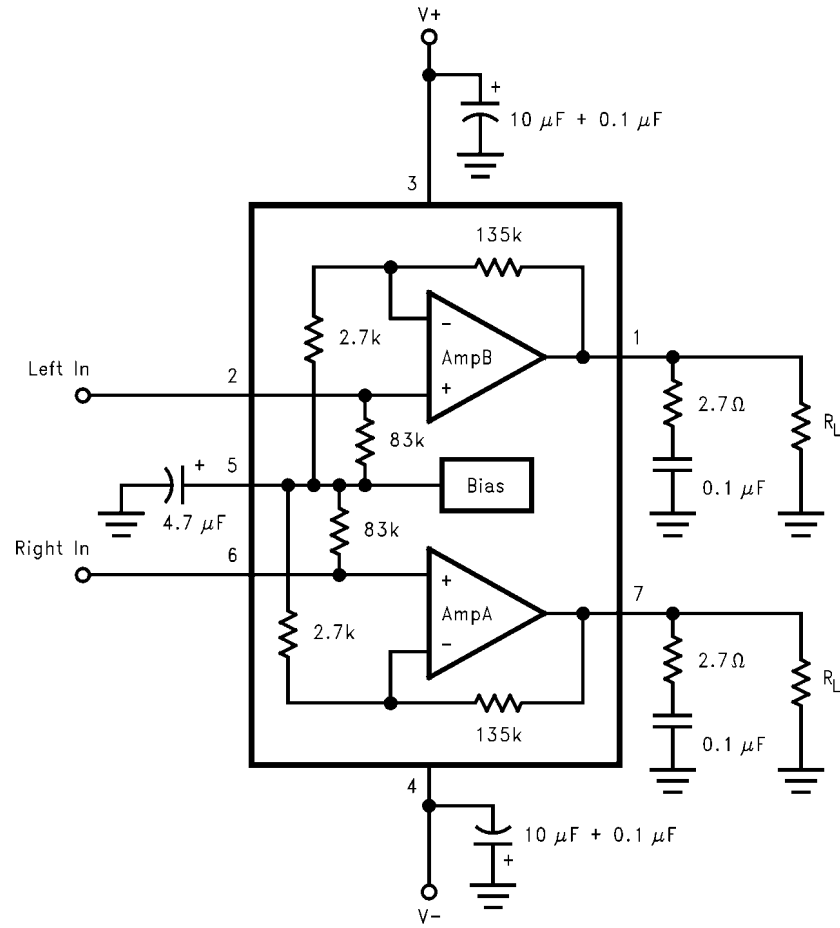

10003936

FIGURE 2. Test Circuit

Typical Application with Mute

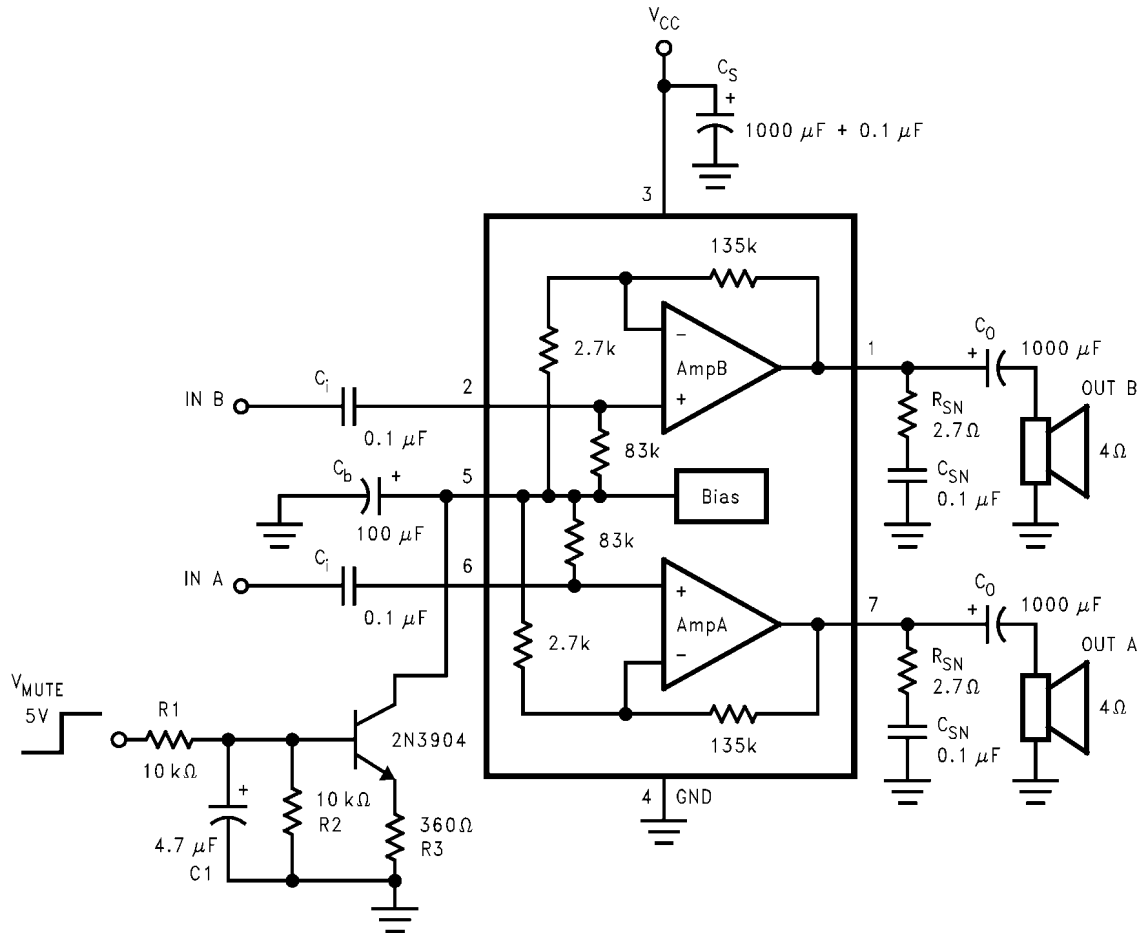

10003903

FIGURE 3. Application with Mute Function

Equivalent Schematic Diagram

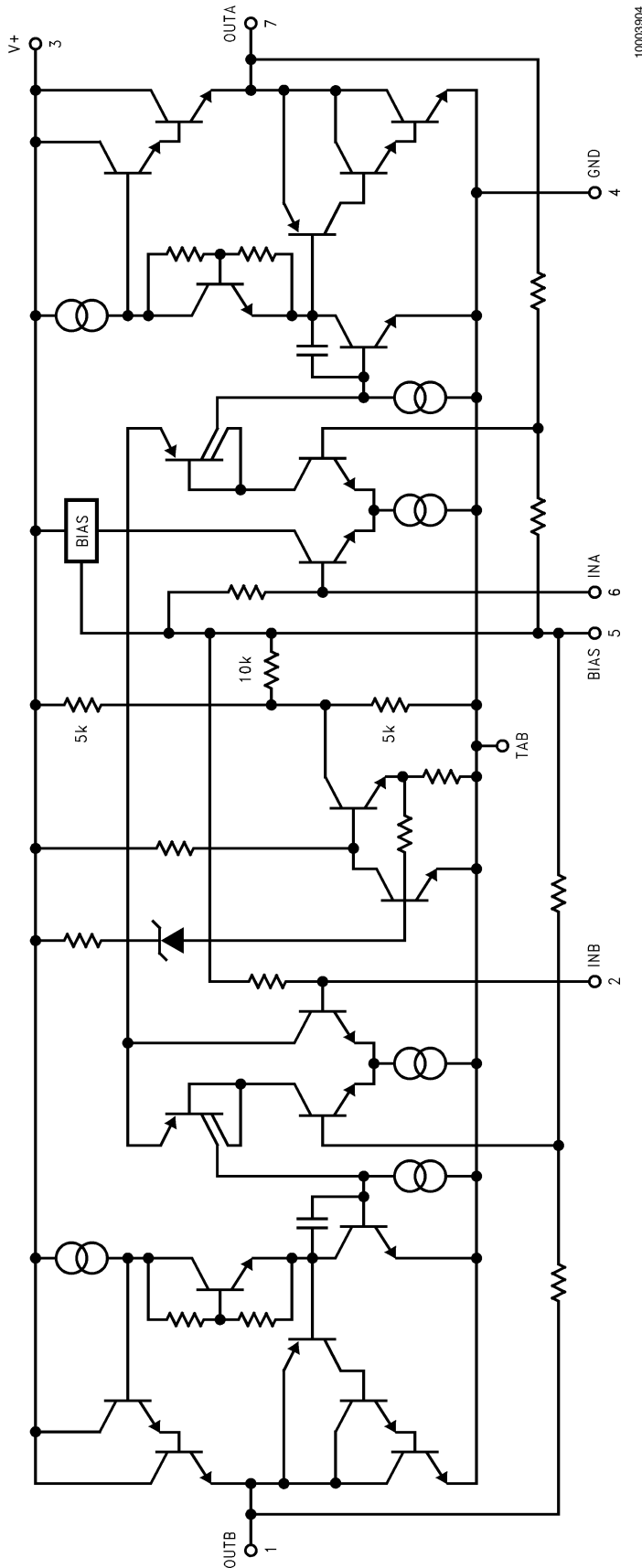

10003904

System Application Circuit

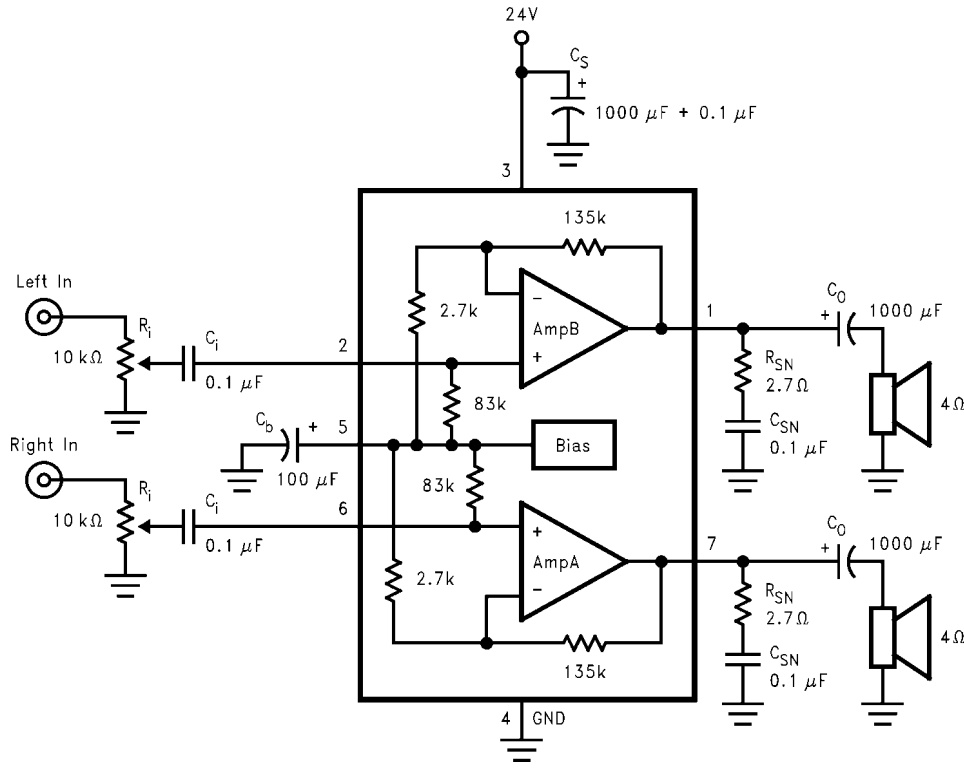

10003905

FIGURE 4. Circuit for External Components Description

External Components Description

Components	Function Description
1, 2 Cs	Provides power supply filtering and bypassing.
3, 4 Rsn	Works with Csn to stabilize the output stage from high frequency oscillations.
5, 6 Csn	Works with Rsn to stabilize the output stage from high frequency oscillations.
7 Cb	Provides filtering for the internally generated half-supply bias generator.
8, 9 Ci	Input AC coupling capacitor which blocks DC voltage at the amplifier's input terminals. Also creates a high pass filter with $f_c = 1/(2 \cdot \pi \cdot R_{in} \cdot C_{in})$.
10, 11 Co	Output AC coupling capacitor which blocks DC voltage at the amplifier's output terminal. Creates a high pass filter with $f_c = 1/(2 \cdot \pi \cdot R_{out} \cdot C_{out})$.
12, 13 Ri	Voltage control - limits the voltage level to the amplifier's input terminals.

Typical Performance Characteristics

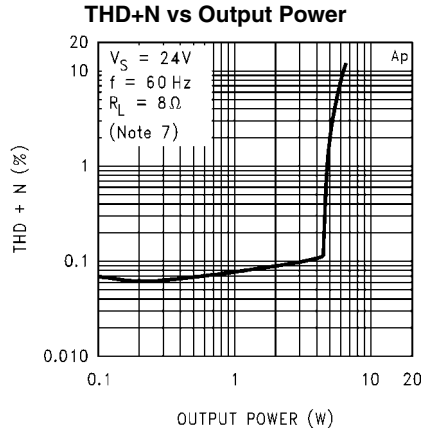

10003912

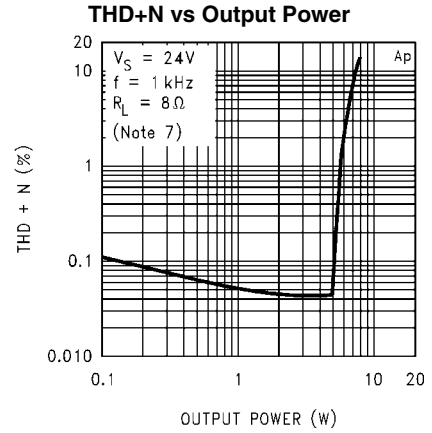

10003913

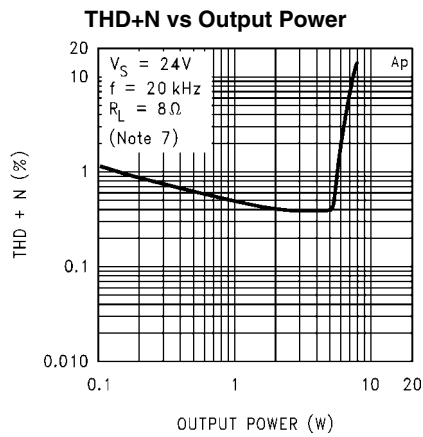

10003914

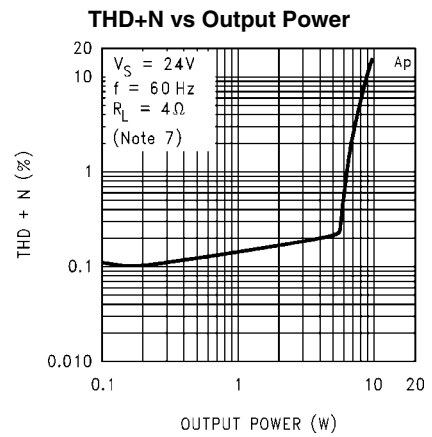

10003906

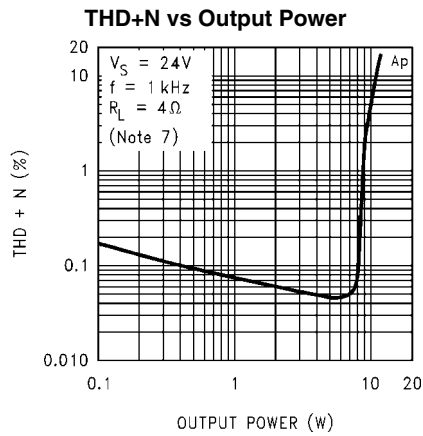

10003907

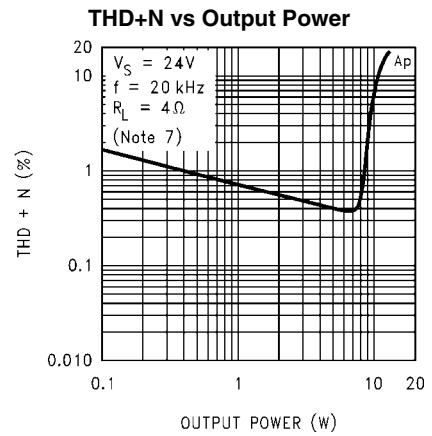

10003908

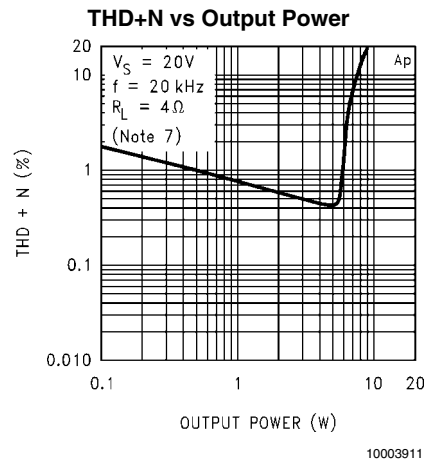
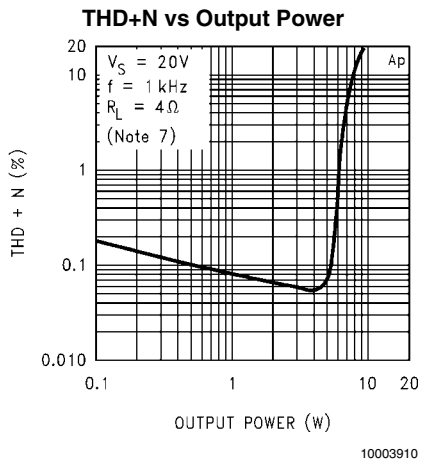
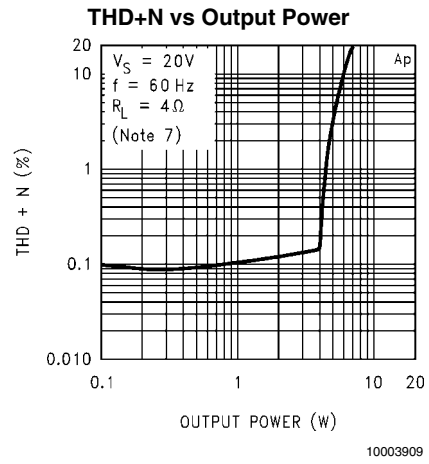
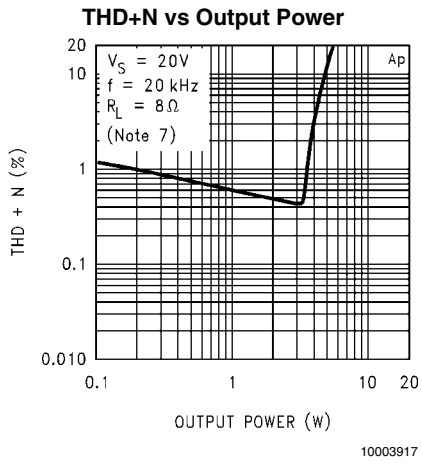
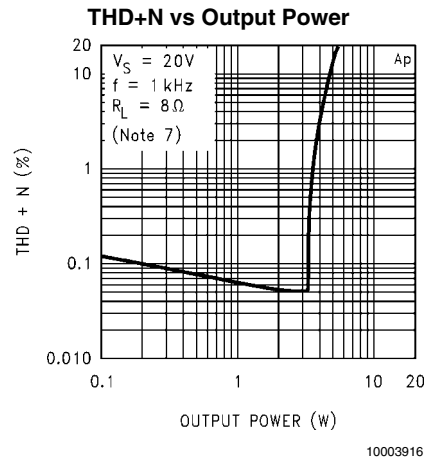
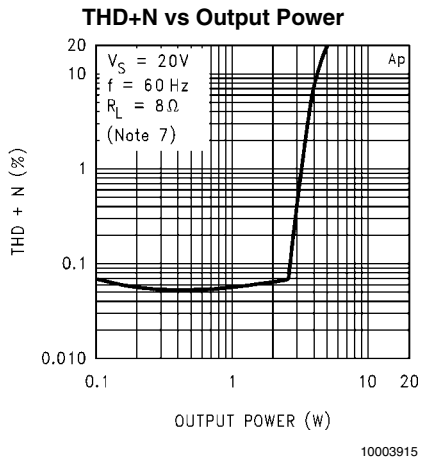

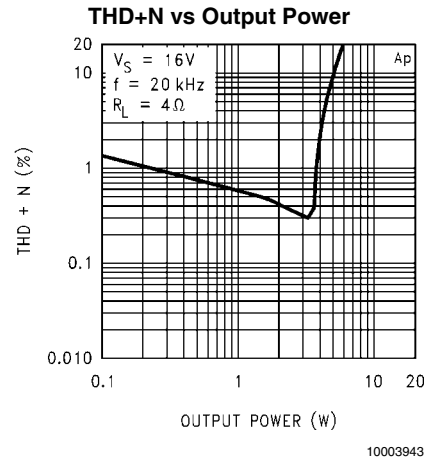
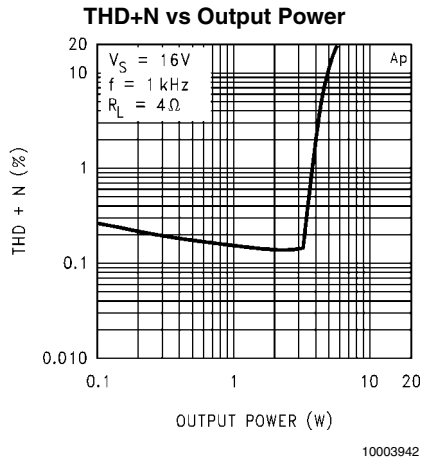
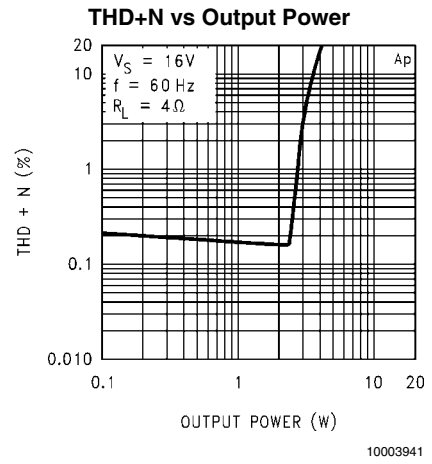
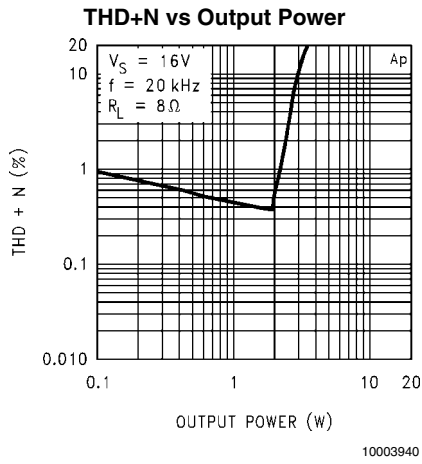
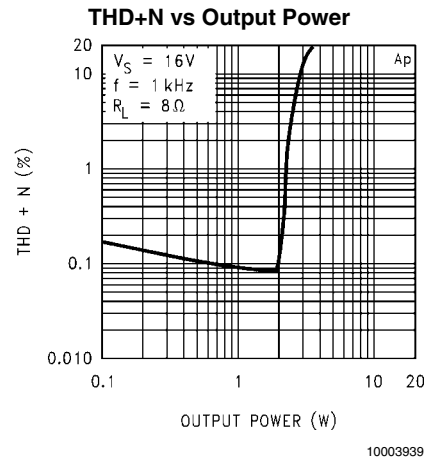
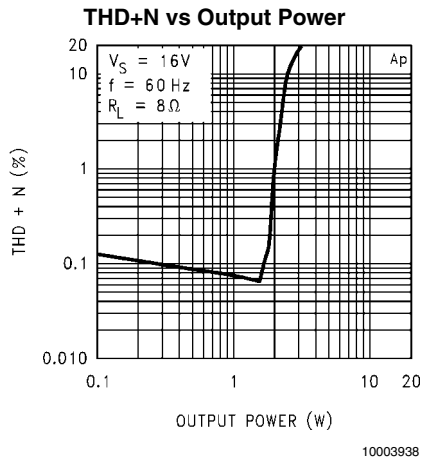

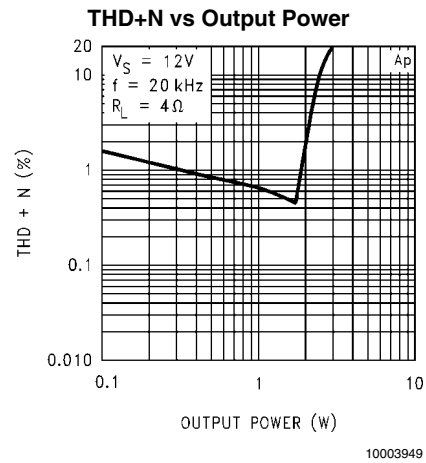
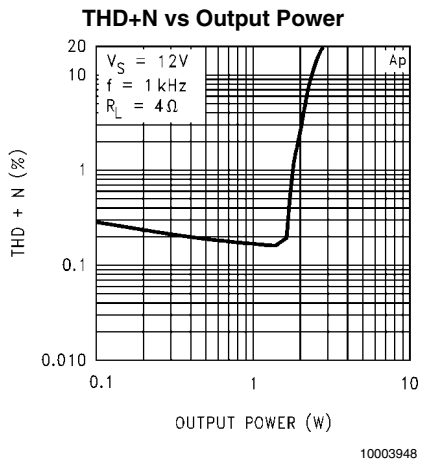
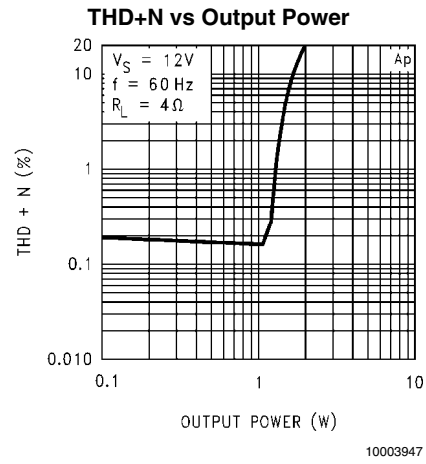
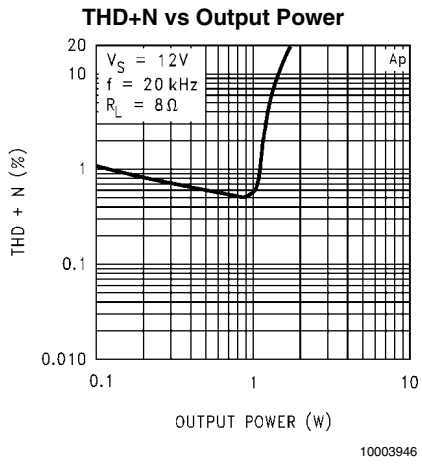
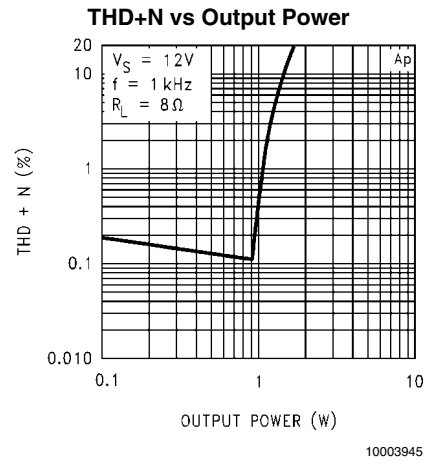
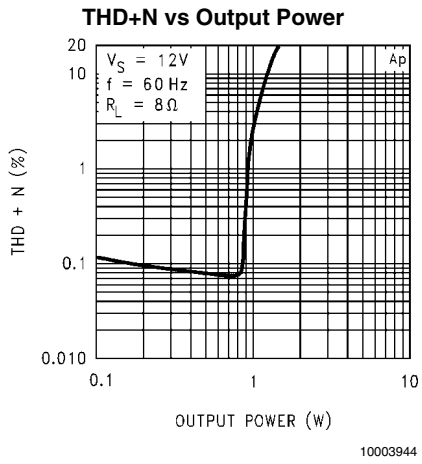

Output Power vs Supply Voltage

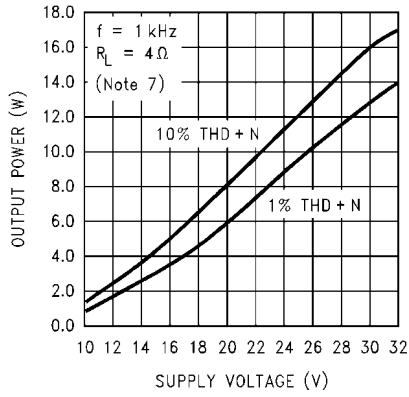

10003918

Output Power vs Supply Voltage

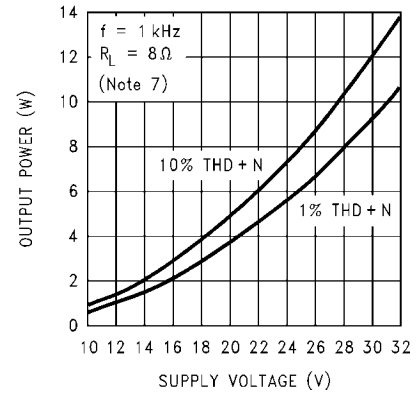

10003919

Frequency Response

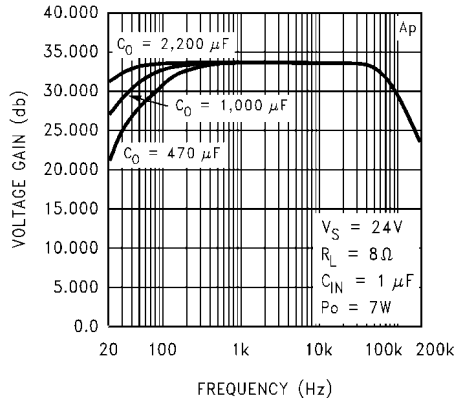

10003920

THD+N vs Frequency

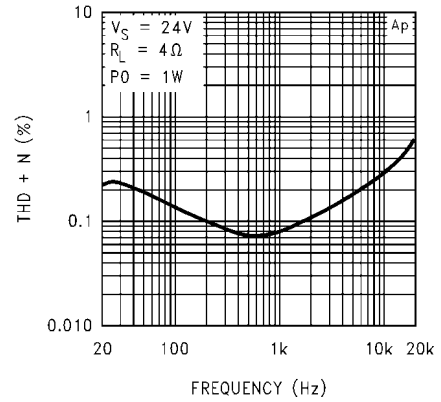

10003921

THD+N vs Frequency

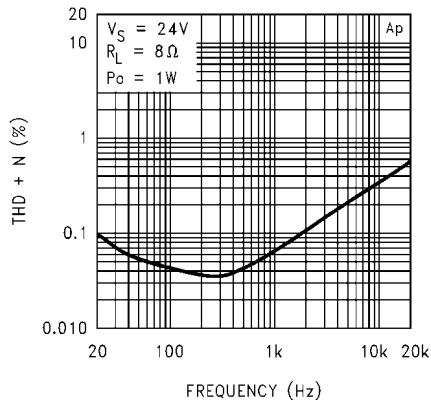

10003922

Frequency Response

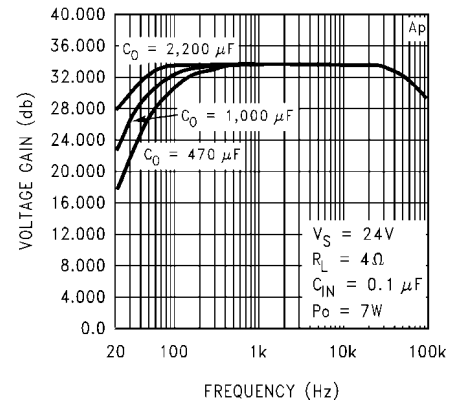

10003923

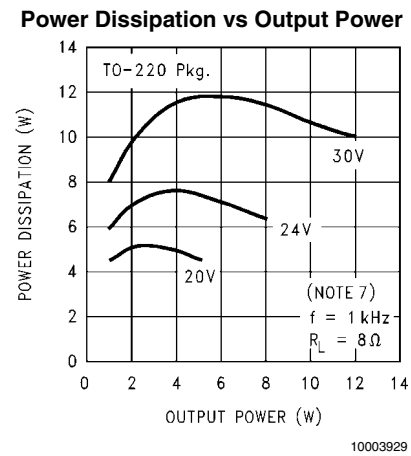
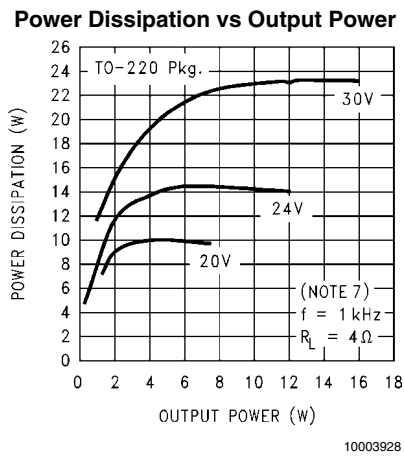
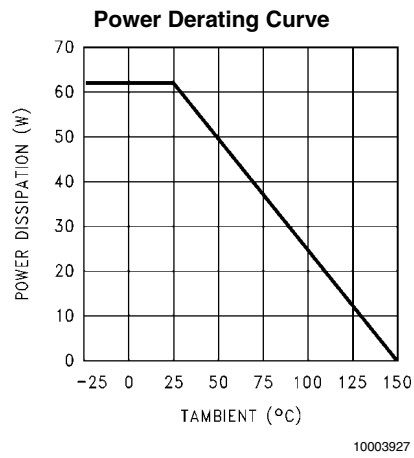
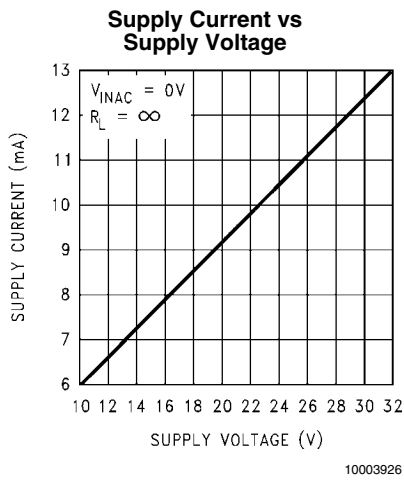
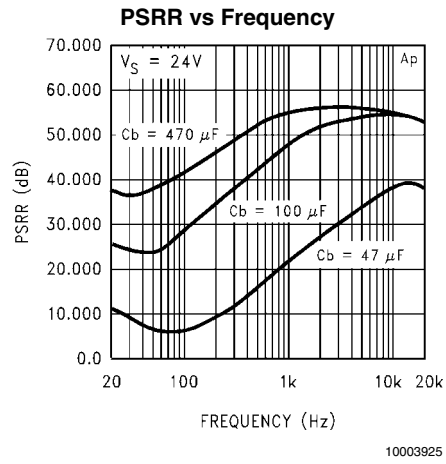
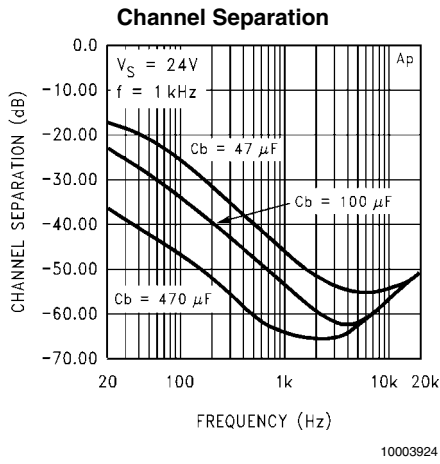

Power Dissipation vs Output Power

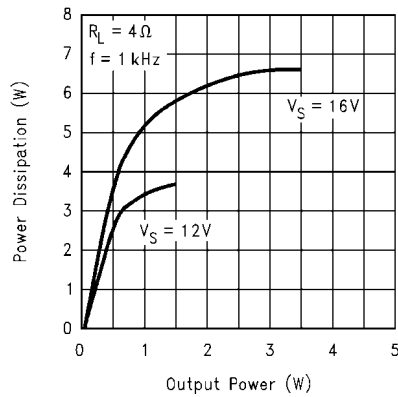

10003951

Power Dissipation vs Output Power

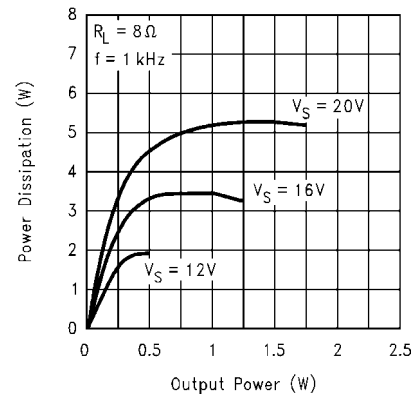

10003952

Application Information

CAPACITOR SELECTION AND FREQUENCY RESPONSE

With the LM4752, as in all single supply amplifiers, AC coupling capacitors are used to isolate the DC voltage present at the inputs (pins 2,6) and outputs (pins 1,7). As mentioned earlier in the **External Components** section these capacitors create high-pass filters with their corresponding input/output impedances. The **Typical Application Circuit** shown in *Figure 1* shows input and output capacitors of 0.1 μF and 1,000 μF respectively. At the input, with an 83 $\text{k}\Omega$ typical input resistance, the result is a high pass 3 dB point occurring at 19 Hz. There is another high pass filter at 39.8 Hz created with the output load resistance of 4 Ω . Careful selection of these components is necessary to ensure that the desired frequency response is obtained. The **Frequency Response** curves in the **Typical Performance Characteristics** section show how different output coupling capacitors affect the low frequency rolloff.

APPLICATION CIRCUIT WITH MUTE

With the addition of a few external components, a simple mute circuit can be implemented, such as the one shown in *Figure 3*. This circuit works by externally pulling down the half supply bias line (pin 5), effectively shutting down the input stage.

When using an external circuit to pull down the bias, care must be taken to ensure that this line is not pulled down too quickly, or output "pops" or signal feedthrough may result. If the bias line is pulled down too quickly, currents induced in the internal bias resistors will cause a momentary DC voltage to appear across the inputs of each amplifier's internal differential pair,

resulting in an output DC shift towards V_{SUPPLY} . An R-C timing circuit should be used to limit the pull-down time such that output "pops" and signal feedthroughs will be minimized. The pull-down timing is a function of a number of factors, including the external mute circuitry, the voltage used to activate the mute, the bias capacitor, the half-supply voltage, and internal resistances used in the half-supply generator. *Table 1* shows a list of recommended values for the external mute circuitry.

TABLE 1. Values for Mute Circuit

V_{MUTE}	R1	R2	C1	R3	C_{B}	V_{CC}
5V	10 $\text{k}\Omega$	10 $\text{k}\Omega$	4.7 μF	360 Ω	100 μF	21V–32V
V_{S}	20 $\text{k}\Omega$	1.2 $\text{k}\Omega$	4.7 μF	180 Ω	100 μF	15V–32V
V_{S}	20 $\text{k}\Omega$	910 Ω	4.7 μF	180 Ω	47 μF	22V–32V

OPERATING IN BRIDGE-MODE

Though designed for use as a single-ended amplifier, the LM4752 can be used to drive a load differentially (bridge-mode). Due to the low pin count of the package, only the non-inverting inputs are available. An inverted signal must be provided to one of the inputs. This can easily be done with the use of an inexpensive op-amp configured as a standard inverting amplifier. An LF353 is a good low-cost choice. Care must be taken, however, for a bridge-mode amplifier must theoretically dissipate four times the power of a single-ended type. The load seen by each amplifier is effectively half that of the actual load being used, thus an amplifier designed to drive a 4 Ω load in single-ended mode should drive an 8 Ω load when operating in bridge-mode.

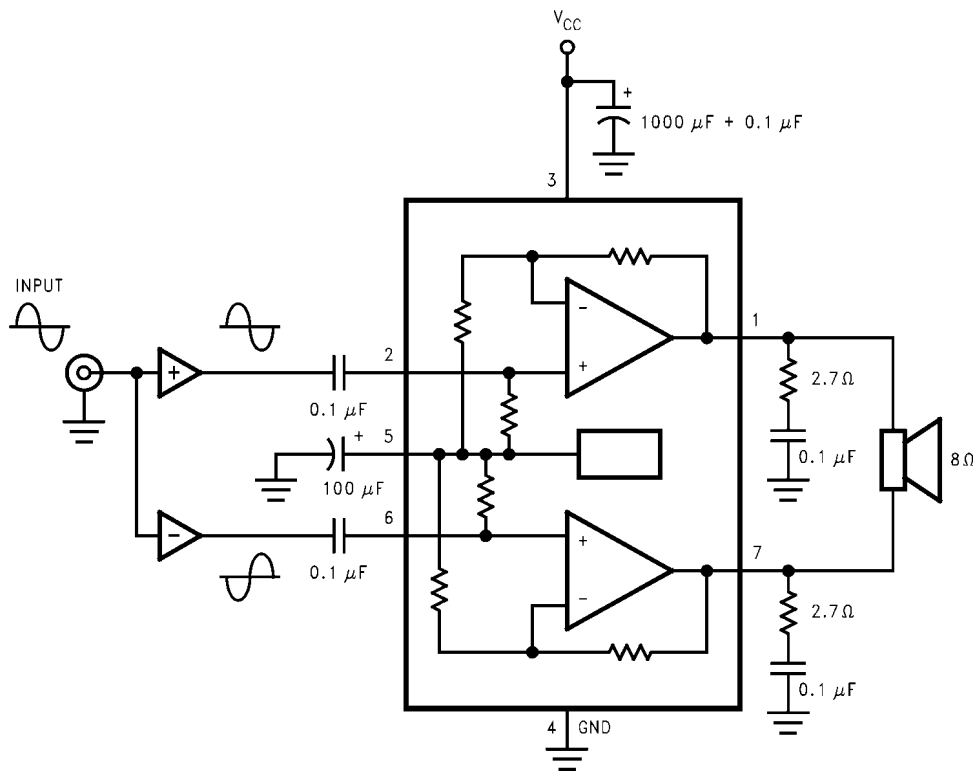

10003930

FIGURE 5. Bridge-Mode Application

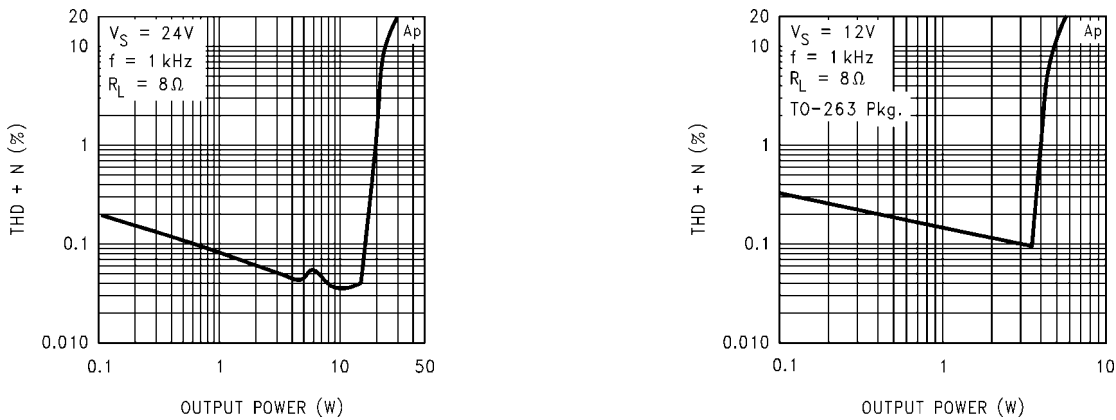

10003931

10003937

FIGURE 6. THD+N vs. P_{OUT} for Bridge-Mode Application

PREVENTING OSCILLATIONS

With the integration of the feedback and bias resistors on-chip, the LM4752 fits into a very compact package. However, due to the close proximity of the non-inverting input pins to the corresponding output pins, the inputs should be AC terminated at all times. If the inputs are left floating, the amplifier will have a positive feedback path through high impedance coupling, resulting in a high frequency oscillation. In most applications, this termination is typically provided by the previous stage's source impedance. If the application will require an external signal, the inputs should be terminated to ground with a resistance of 50 kΩ or less on the AC side of the input coupling capacitors.

UNDERVOLTAGE SHUTDOWN

If the power supply voltage drops below the minimum operating supply voltage, the internal under-voltage detection circuitry pulls down the half-supply bias line, shutting down the preamp section of the LM4752. Due to the wide operating supply range of the LM4752, the threshold is set to just under 9V. There may be certain applications where a higher threshold voltage is desired. One example is a design requiring a high operating supply voltage, with large supply and bias capacitors, and there is little or no other circuitry connected to the main power supply rail. In this circuit, when the power is disconnected, the supply and bias capacitors will discharge at a slower rate, possibly resulting in audible output distortion as the decaying voltage begins to clip the output signal. An

external circuit may be used to sense for the desired threshold, and pull the bias line (pin5) to ground to disable the input preamp. Figure 7 shows an example of such a circuit. When the voltage across the zener diode drops below its threshold, current flow into the base of Q1 is interrupted. Q2 then turns on, discharging the bias capacitor. This discharge rate is governed by several factors, including the bias capacitor value, the bias voltage, and the resistor at the emitter of Q2. An equation for approximating the value of the emitter discharge resistor, R, is given below:

$$R = (0.7V) / (C_B \cdot (V_S / 2) / 0.1s)$$

Note that this is only a linearized approximation based on a discharge time of 0.1s. The circuit should be evaluated and adjusted for each application.

As mentioned earlier in the **Application Circuit with Mute** section, when using an external circuit to pull down the bias line, the rate of discharge will have an effect on the turn-off induced distortions. Please refer to the **Application Circuit with Mute** section for more information.

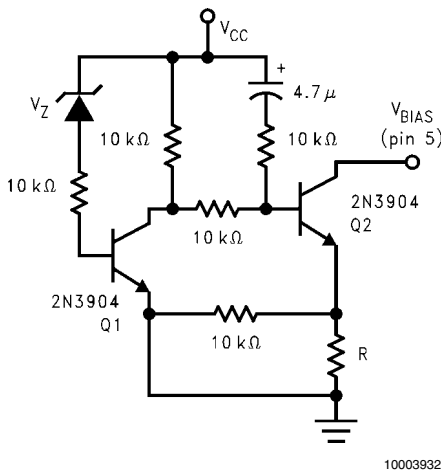

FIGURE 7. External Undervoltage Pull-Down

THERMAL CONSIDERATIONS

Heat Sinking

Proper heatsinking is necessary to ensure that the amplifier will function correctly under all operating conditions. A heatsink that is too small will cause the die to heat excessively and will result in a degraded output signal as the internal thermal protection circuitry begins to operate.

The choice of a heatsink for a given application is dictated by several factors: the maximum power the IC needs to dissipate, the worst-case ambient temperature of the circuit, the junction-to-case thermal resistance, and the maximum junction temperature of the IC. The heat flow approximation equation used in determining the correct heatsink maximum thermal resistance is given below:

$$T_J - T_A = P_{DMAX} \cdot (\theta_{JC} + \theta_{CS} + \theta_{SA})$$

where:

P_{DMAX} = maximum power dissipation of the IC

T_J (°C) = junction temperature of the IC

T_A (°C) = ambient temperature

θ_{JC} (°C/W) = junction-to-case thermal resistance of the IC

θ_{CS} (°C/W) = case-to-heatsink thermal resistance (typically 0.2 to 0.5 °C/W)

θ_{SA} (°C/W) = thermal resistance of heatsink

When determining the proper heatsink, the above equation should be re-written as:

$$\theta_{SA} \leq [(T_J - T_A) / P_{DMAX}] - \theta_{JC} - \theta_{CS}$$

TO-263 Heatsinking

Surface mount applications will be limited by the thermal dissipation properties of printed circuit board area. The TO-263 package is not recommended for surface mount applications with $V_S > 16V$ due to limited printed circuit board area. There are TO-263 package enhancements, such as clip-on heatsinks and heatsinks with adhesives, that can be used to improve performance.

Standard FR-4 single-sided copper clad will have an approximate Thermal resistance (θ_{SA}) ranging from:

$$\begin{array}{ll} 1.5 \times 1.5 \text{ in. sq.} & 20\text{--}27^\circ\text{C/W} \quad (T_A=28^\circ\text{C, Sine wave} \\ 2 \times 2 \text{ in. sq.} & 16\text{--}23^\circ\text{C/W} \quad \text{testing, 1 oz. Copper}) \end{array}$$

The above values for θ_{SA} vary widely due to dimensional proportions (i.e. variations in width and length will vary θ_{SA}).

For audio applications, where peak power levels are short in duration, this part will perform satisfactory with less heatsinking/copper clad area. As with any high power design proper bench testing should be undertaken to assure the design can dissipate the required power. Proper bench testing requires attention to worst case ambient temperature and air flow. At high power dissipation levels the part will show a tendency to increase saturation voltages, thus limiting the undistorted power levels.

Determining Maximum Power Dissipation

For a single-ended class AB power amplifier, the theoretical maximum power dissipation point is a function of the supply voltage, V_S , and the load resistance, R_L and is given by the following equation:

(single channel)

$$P_{DMAX} (W) = [V_S^2 / (2 \cdot \pi^2 \cdot R_L)]$$

The above equation is for a single channel class-AB power amplifier. For dual amplifiers such as the LM4752, the equation for calculating the total maximum power dissipated is:

(dual channel)

$$P_{DMAX} (W) = 2 \cdot [V_S^2 / (2 \cdot \pi^2 \cdot R_L)]$$

or

$$V_S^2 / (\pi^2 \cdot R_L)$$

(Bridged Outputs)

$$P_{DMAX} (W) = 4[V_S^2 / (2\pi^2 \cdot R_L)]$$

Heatsink Design Example

Determine the system parameters:

$V_S = 24V$	Operating Supply Voltage
$R_L = 4\Omega$	Minimum load impedance
$T_A = 55^\circ\text{C}$	Worst case ambient temperature

Device parameters from the datasheet:

$T_J = 150^\circ\text{C}$	Maximum junction temperature
$\theta_{JC} = 2^\circ\text{C/W}$	Junction-to-case thermal resistance

Calculations:

$$2 \cdot P_{\text{DMAX}} = 2 \cdot [V_S^2 / (2 \cdot \pi^2 \cdot R_L)] = (24V)^2 / (2 \cdot \pi^2 \cdot 4\Omega) = 14.6W$$

$$\theta_{\text{SA}} \leq [(T_J - T_A) / P_{\text{DMAX}}] - \theta_{\text{JC}} - \theta_{\text{CS}} = [(150^\circ\text{C} - 55^\circ\text{C}) / 14.6W] - 2^\circ\text{C/W} - 0.2^\circ\text{C/W} = 4.3^\circ\text{C/W}$$

Conclusion: Choose a heatsink with $\theta_{\text{SA}} \leq 4.3^\circ\text{C/W}$.

TO-263 Heatsink Design Examples

Example 1: (Stereo Single-Ended Output)

Given: $T_A=30^\circ\text{C}$
 $T_J=150^\circ\text{C}$
 $R_L=4\Omega$
 $V_S=12V$
 $\theta_{\text{JC}}=2^\circ\text{C/W}$

P_{DMAX} from P_D vs P_O Graph:

$$P_{\text{DMAX}} \approx 3.7W$$

Calculating P_{DMAX} :

$$P_{\text{DMAX}} = V_{\text{CC}}^2 / (\pi^2 R_L) = (12V)^2 / \pi^2(4\Omega) = 3.65W$$

Calculating Heatsink Thermal Resistance:

$$\theta_{\text{SA}} < [(T_J - T_A) / P_{\text{DMAX}}] - \theta_{\text{JC}} - \theta_{\text{CS}}$$

$$\theta_{\text{SA}} < 120^\circ\text{C} / 3.7W - 2.0^\circ\text{C/W} - 0.2^\circ\text{C/W} = 30.2^\circ\text{C/W}$$

Therefore the recommendation is to use 1.5×1.5 square inch of single-sided copper clad.

Example 2: (Stereo Single-Ended Output)

Given: $T_A=50^\circ\text{C}$
 $T_J=150^\circ\text{C}$
 $R_L=4\Omega$
 $V_S=12V$
 $\theta_{\text{JC}}=2^\circ\text{C/W}$

P_{DMAX} from P_D vs P_O Graph:

$$P_{\text{DMAX}} \approx 3.7W$$

Calculating P_{DMAX} :

$$P_{\text{DMAX}} = V_{\text{CC}}^2 / (\pi^2 R_L) = (12V)^2 / (\pi^2(4\Omega)) = 3.65W$$

Calculating Heatsink Thermal Resistance:

$$\theta_{\text{SA}} < [(T_J - T_A) / P_{\text{DMAX}}] - \theta_{\text{JC}} - \theta_{\text{CS}}$$

$$\theta_{\text{SA}} < 100^\circ\text{C} / 3.7W - 2.0^\circ\text{C/W} - 0.2^\circ\text{C/W} = 24.8^\circ\text{C/W}$$

Therefore the recommendation is to use 2.0×2.0 square inch of single-sided copper clad.

Example 3: (Bridged Output)

Given: $T_A=50^\circ\text{C}$
 $T_J=150^\circ\text{C}$
 $R_L=8\Omega$
 $V_S=12V$
 $\theta_{\text{JC}}=2^\circ\text{C/W}$

Calculating P_{DMAX} :

$$P_{\text{DMAX}} = 4[V_{\text{CC}}^2 / (2\pi^2 R_L)] = 4(12V)^2 / (2\pi^2(8\Omega)) = 3.65W$$

Calculating Heatsink Thermal Resistance:

$$\theta_{\text{SA}} < [(T_J - T_A) / P_{\text{DMAX}}] - \theta_{\text{JC}} - \theta_{\text{CS}}$$

$$\theta_{\text{SA}} < 100^\circ\text{C} / 3.7W - 2.0^\circ\text{C/W} - 0.2^\circ\text{C/W} = 24.8^\circ\text{C/W}$$

Therefore the recommendation is to use 2.0×2.0 square inch of single-sided copper clad.

Layout and Ground Returns

Proper PC board layout is essential for good circuit performance. When laying out a PC board for an audio power amplifier, particular attention must be paid to the routing of the output signal ground returns relative to the input signal and bias capacitor grounds. To prevent any ground loops, the ground returns for the output signals should be routed separately and brought together at the supply ground. The input signal grounds and the bias capacitor ground line should also be routed separately. The $0.1 \mu\text{F}$ high frequency supply bypass capacitor should be placed as close as possible to the IC.

PC BOARD LAYOUT—COMPOSITE

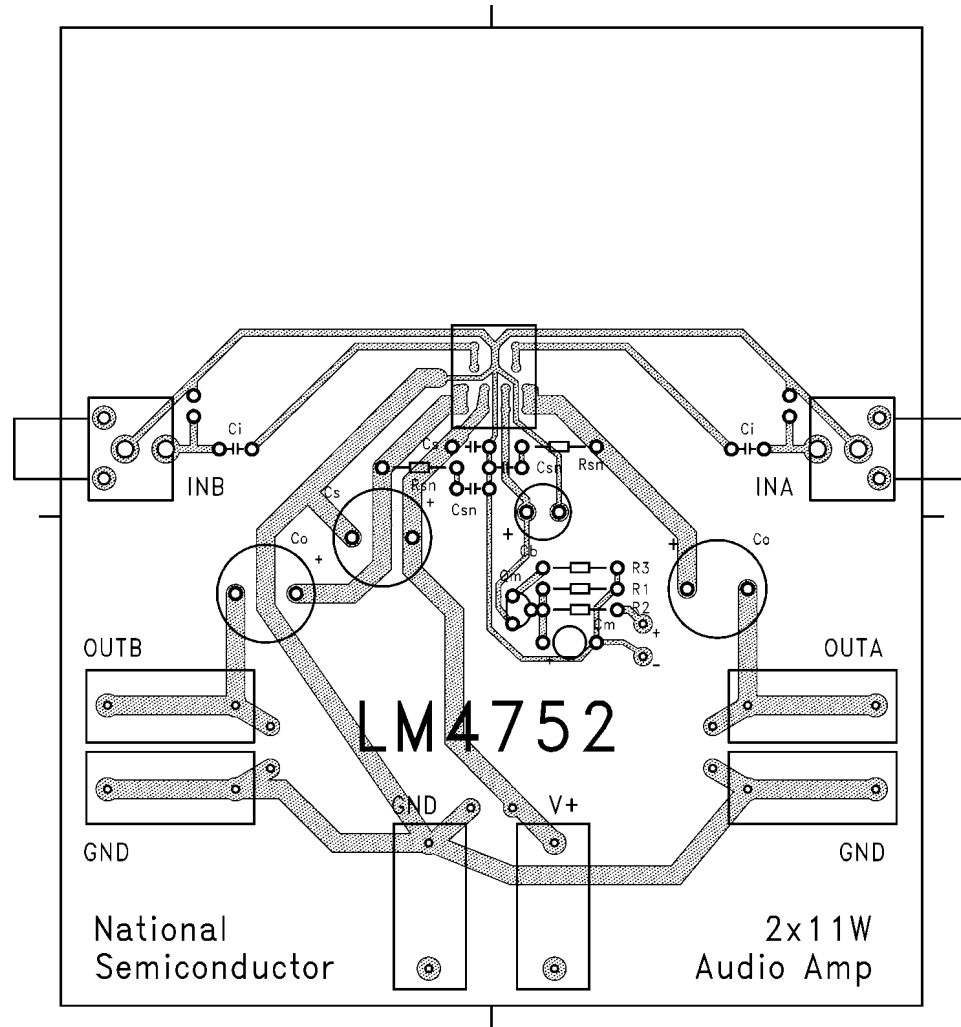

10003933

PC BOARD LAYOUT—SILK SCREEN

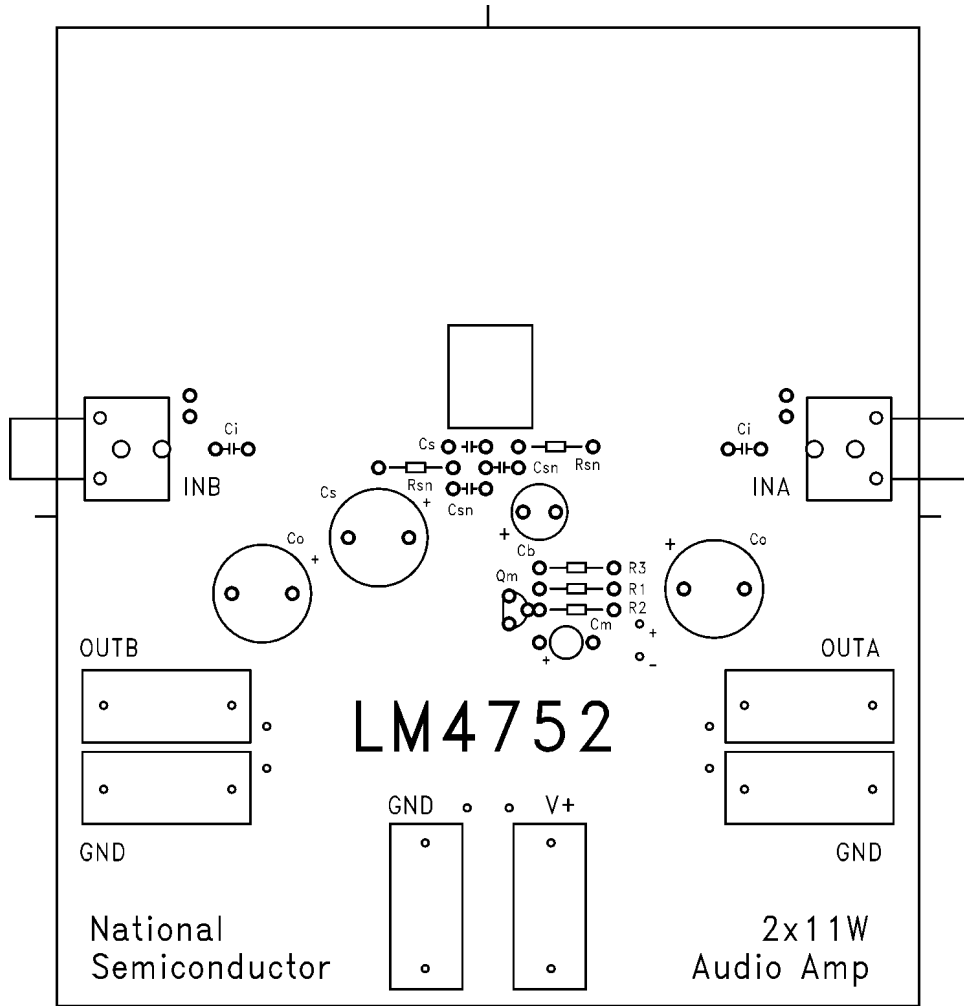

10003934

PC BOARD LAYOUT—SOLDER SIDE

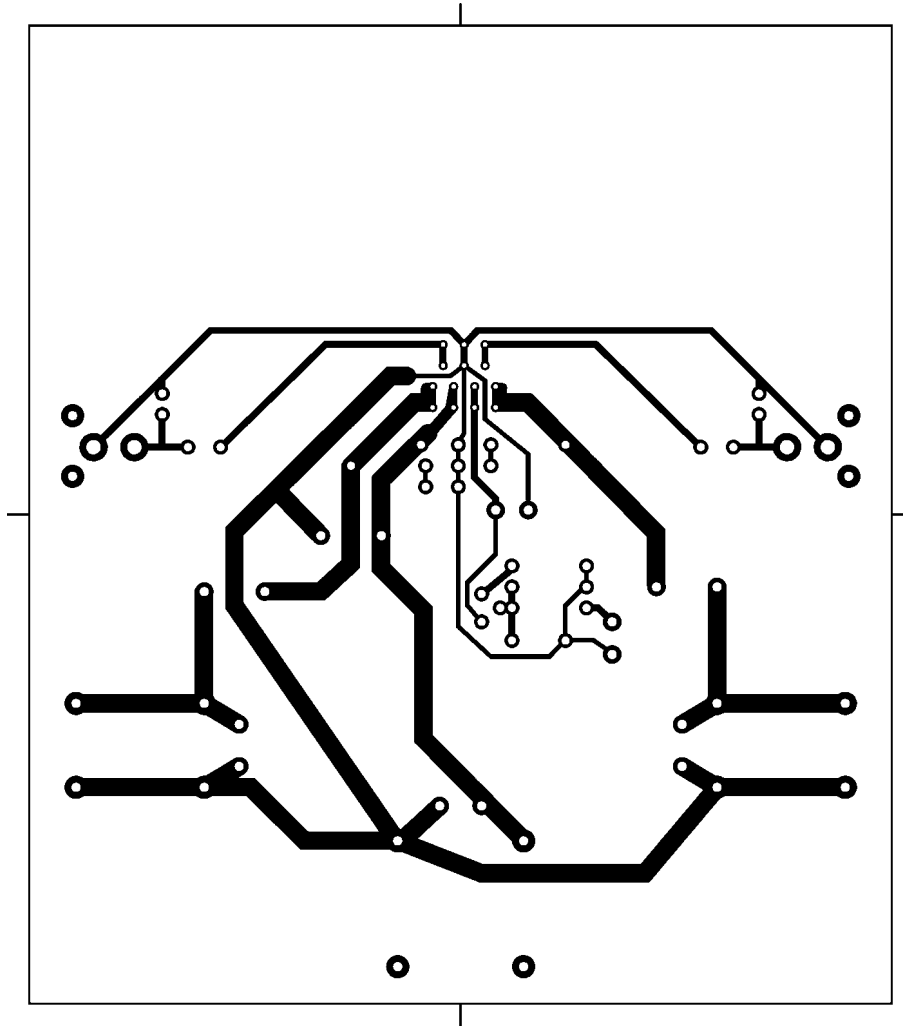

10003935

Physical Dimensions inches (millimeters) unless otherwise noted

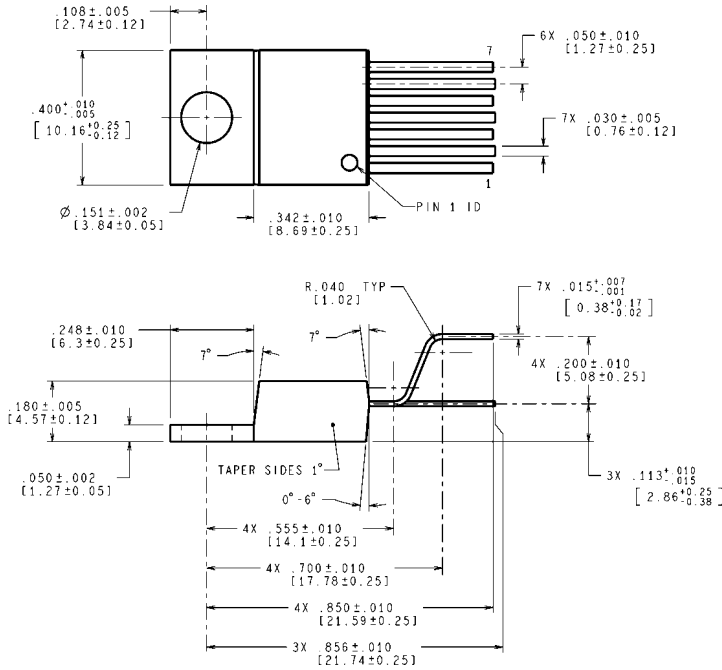

CONTROLLING DIMENSIONS IS INCH
VALUES IN [] ARE MILLIMETERS

TA07B (Rev E)

Order Number LM4752T
NS Package Number TA07B

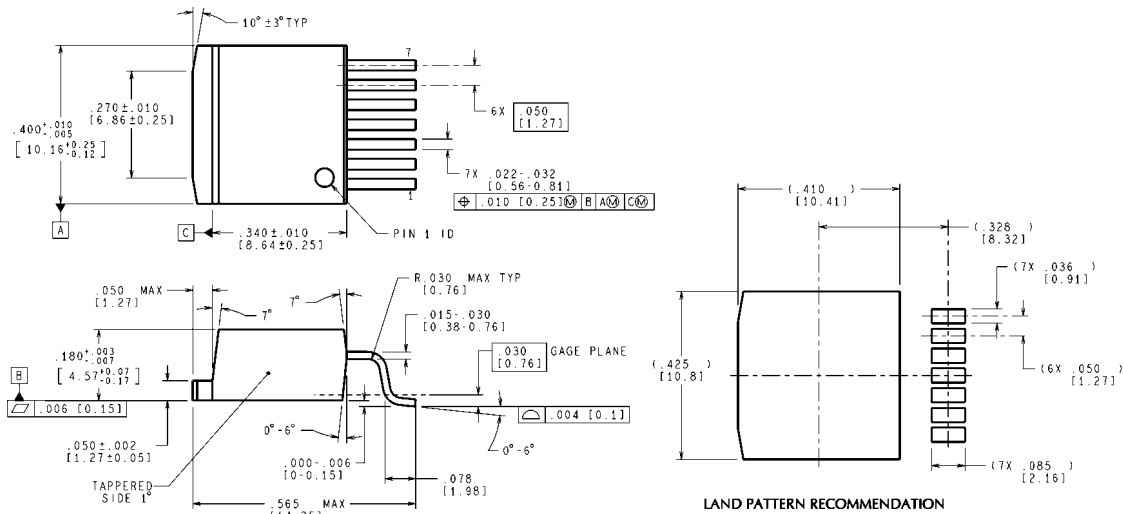

CONTROLLING DIMENSION IS INCH
VALUES IN [] ARE MILLIMETERS
DIMENSIONS IN () FOR REFERENCE ONLY

TS7B (Rev E)

Order Number LM4752TS
NS Package Number TS7B

Notes

For more National Semiconductor product information and proven design tools, visit the following Web sites at:

Products		Design Support	
Amplifiers	www.national.com/amplifiers	WEBENCH	www.national.com/webench
Audio	www.national.com/audio	Analog University	www.national.com/AU
Clock Conditioners	www.national.com/timing	App Notes	www.national.com/appnotes
Data Converters	www.national.com/adc	Distributors	www.national.com/contacts
Displays	www.national.com/displays	Green Compliance	www.national.com/quality/green
Ethernet	www.national.com/ethernet	Packaging	www.national.com/packaging
Interface	www.national.com/interface	Quality and Reliability	www.national.com/quality
LVDS	www.national.com/lvds	Reference Designs	www.national.com/refdesigns
Power Management	www.national.com/power	Feedback	www.national.com/feedback
Switching Regulators	www.national.com/switchers		
LDOs	www.national.com/lido		
LED Lighting	www.national.com/led		
PowerWise	www.national.com/powerwise		
Serial Digital Interface (SDI)	www.national.com/sdi		
Temperature Sensors	www.national.com/tempsensors		
Wireless (PLL/VCO)	www.national.com/wireless		

THE CONTENTS OF THIS DOCUMENT ARE PROVIDED IN CONNECTION WITH NATIONAL SEMICONDUCTOR CORPORATION ("NATIONAL") PRODUCTS. NATIONAL MAKES NO REPRESENTATIONS OR WARRANTIES WITH RESPECT TO THE ACCURACY OR COMPLETENESS OF THE CONTENTS OF THIS PUBLICATION AND RESERVES THE RIGHT TO MAKE CHANGES TO SPECIFICATIONS AND PRODUCT DESCRIPTIONS AT ANY TIME WITHOUT NOTICE. NO LICENSE, WHETHER EXPRESS, IMPLIED, ARISING BY ESTOPPEL OR OTHERWISE, TO ANY INTELLECTUAL PROPERTY RIGHTS IS GRANTED BY THIS DOCUMENT.

TESTING AND OTHER QUALITY CONTROLS ARE USED TO THE EXTENT NATIONAL DEEMS NECESSARY TO SUPPORT NATIONAL'S PRODUCT WARRANTY. EXCEPT WHERE MANDATED BY GOVERNMENT REQUIREMENTS, TESTING OF ALL PARAMETERS OF EACH PRODUCT IS NOT NECESSARILY PERFORMED. NATIONAL ASSUMES NO LIABILITY FOR APPLICATIONS ASSISTANCE OR BUYER PRODUCT DESIGN. BUYERS ARE RESPONSIBLE FOR THEIR PRODUCTS AND APPLICATIONS USING NATIONAL COMPONENTS. PRIOR TO USING OR DISTRIBUTING ANY PRODUCTS THAT INCLUDE NATIONAL COMPONENTS, BUYERS SHOULD PROVIDE ADEQUATE DESIGN, TESTING AND OPERATING SAFEGUARDS.

EXCEPT AS PROVIDED IN NATIONAL'S TERMS AND CONDITIONS OF SALE FOR SUCH PRODUCTS, NATIONAL ASSUMES NO LIABILITY WHATSOEVER, AND NATIONAL DISCLAIMS ANY EXPRESS OR IMPLIED WARRANTY RELATING TO THE SALE AND/OR USE OF NATIONAL PRODUCTS INCLUDING LIABILITY OR WARRANTIES RELATING TO FITNESS FOR A PARTICULAR PURPOSE, MERCHANTABILITY, OR INFRINGEMENT OF ANY PATENT, COPYRIGHT OR OTHER INTELLECTUAL PROPERTY RIGHT.

LIFE SUPPORT POLICY

NATIONAL'S PRODUCTS ARE NOT AUTHORIZED FOR USE AS CRITICAL COMPONENTS IN LIFE SUPPORT DEVICES OR SYSTEMS WITHOUT THE EXPRESS PRIOR WRITTEN APPROVAL OF THE CHIEF EXECUTIVE OFFICER AND GENERAL COUNSEL OF NATIONAL SEMICONDUCTOR CORPORATION. As used herein:

Life support devices or systems are devices which (a) are intended for surgical implant into the body, or (b) support or sustain life and whose failure to perform when properly used in accordance with instructions for use provided in the labeling can be reasonably expected to result in a significant injury to the user. A critical component is any component in a life support device or system whose failure to perform can be reasonably expected to cause the failure of the life support device or system or to affect its safety or effectiveness.

National Semiconductor and the National Semiconductor logo are registered trademarks of National Semiconductor Corporation. All other brand or product names may be trademarks or registered trademarks of their respective holders.

Copyright© 2008 National Semiconductor Corporation

For the most current product information visit us at www.national.com



National Semiconductor Americas Technical Support Center
Email: support@nsc.com
Tel: 1-800-272-9959

National Semiconductor Europe Technical Support Center
Email: europe.support@nsc.com
German Tel: +49 (0) 180 5010 771
English Tel: +44 (0) 870 850 4288

National Semiconductor Asia Pacific Technical Support Center
Email: ap.support@nsc.com

National Semiconductor Japan Technical Support Center
Email: jpn.feedback@nsc.com