

FEATURES

Multiformat video decoder supports NTSC-(J, M, 4.43), PAL-(B/D/G/H/I/M/N), SECAM

Integrates three 54 MHz, 9-bit ADCs

Clocked from a single 27 MHz crystal

Line-locked clock-compatible (LLC)

Adaptive Digital Line Length Tracking (ADLLT™)

5-line adaptive comb filters

Proprietary architecture for locking to weak, noisy, and unstable video sources such as VCRs and tuners

Subcarrier frequency lock and status information output

Integrated AGC with adaptive peak white mode

Macrovision® copy protection detection

CTI (chroma transient improvement)

DNR (digital noise reduction)

Multiple programmable analog input formats:

CVBS (composite video)

S-Video (Y/C)

YPrPb component (VESA, MII, SMPTE, and Betacam)

6 analog video input channels

Automatic NTSC/PAL/SECAM identification

Digital output formats (8-bit or 16-bit):

ITU-R BT.656 YCrCb 4:2:2 output + HS, VS, and FIELD

0.5 V to 1.6 V analog signal input range

Differential gain: 0.6% typ

Differential phase: 0.6° typ

Programmable video controls:

Peak-white/hue/brightness/saturation/contrast

Integrated on-chip video timing generator

Free run mode (generates stable video output with no I/P)

VBI decode support for

Close captioning, WSS, CGMS, EDTV, Gemstar® 1x/2x

Power-down mode

2-wire serial MPU interface (I²C®-compatible)

3.3 V analog, 1.8 V digital core; 3.3 V IO supply

Temperature grade: -40°C to +85°C

64-lead LQFP Pb-free package

APPLICATIONS

DVD recorders

PC video

HDD-based PVRs/DVDRs

LCD TVs

Set-top boxes

Security systems

Digital televisions

Portable video devices

Automotive entertainment

AVR receiver

GENERAL DESCRIPTION

The ADV7181 integrated video decoder automatically detects and converts a standard analog baseband television signal compatible with worldwide standards NTSC, PAL, and SECAM into 4:2:2 component video data compatible with 16-/8-bit CCIR601/CCIR656.

The advanced, highly flexible digital output interface enables performance video decoding and conversion in line-locked clock-based systems. This makes the device ideally suited for a broad range of applications with diverse analog video characteristics, including tape-based sources, broadcast sources, security/surveillance cameras, and professional systems.

The six analog input channels accept standard composite, S-Video, YPrPb video signals in an extensive number of combinations. AGC and clamp restore circuitry allow an input video signal peak-to-peak range of 0.5 V up to 1.6 V. Alternatively, these can be bypassed for manual settings.

The fixed 54 MHz clocking of the ADCs and datapath for all modes allow very precise, accurate sampling and digital filtering. The line-locked clock output allows the output data rate, timing signals, and output clock signals to be synchronous, asynchronous, or line locked even with $\pm 5\%$ line length variation. The output control signals allow glueless interface connections in almost any application. The ADV7181 modes are set up over a 2-wire, serial, bidirectional port (I²C-compatible).

The ADV7181 is fabricated in a 3.3 V CMOS process. Its monolithic CMOS construction ensures greater functionality with lower power dissipation.

The ADV7181 is packaged in a small 64-lead LFCSP and LQFP and Pb-free packages.

Rev. B

Information furnished by Analog Devices is believed to be accurate and reliable. However, no responsibility is assumed by Analog Devices for its use, nor for any infringements of patents or other rights of third parties that may result from its use. Specifications subject to change without notice. No license is granted by implication or otherwise under any patent or patent rights of Analog Devices. Trademarks and registered trademarks are the property of their respective owners.

One Technology Way, P.O. Box 9106, Norwood, MA 02062-9106, U.S.A.

Tel: 781.329.4700

Fax: 781.461.3113

www.analog.com

© 2005 Analog Devices, Inc. All rights reserved.

TABLE OF CONTENTS

Introduction	4	Luma Filter	27
Analog Front End.....	4	Chroma Filter	30
Standard Definition Processor	4	Gain Operation.....	31
Functional Block Diagram	5	Chroma Transient Improvement (CTI)	35
Specifications.....	6	Digital Noise Reduction (DNR).....	36
Electrical Characteristics.....	6	Comb Filters	36
Video Specifications.....	7	AV Code Insertion and Controls	39
Timing Specifications	8	Synchronization Output Signals	41
Analog Specifications	8	Sync Processing	49
Thermal Specifications	8	VBI Data Decode	50
Timing Diagrams	9	Pixel Port Configuration	61
Absolute Maximum Ratings.....	10	MPU Port Description.....	62
ESD Caution.....	10	Register Accesses.....	63
Pin Configuration and Function Descriptions.....	11	Register Programming	63
Analog Front End	13	I ² C Sequencer.....	63
Analog Input Muxing	13	I ² C Control Register Map.....	64
Global Control Registers	15	I ² C Register Map Details	67
Power-Save Modes	15	I ² C Programming Examples.....	93
Reset Control	15	Mode 1—CVBS Input (Composite Video on AIN6)	93
Global Pin Control.....	16	Mode 2—S-Video Input (Y on AIN1 and C on AIN4).....	94
Global Status Registers.....	18	Mode 3—525i/625i YPrPb Input (Y on AIN1, Pr on AIN3, and Pb on AIN5)	94
Identification.....	18	Mode 4—CVBS Tuner Input CVBS PAL on AIN6	95
Status 1	18	PCB Layout Recommendations.....	96
Status 2.....	19	Analog Interface Inputs.....	96
Status 3.....	19	Power Supply Decoupling.....	96
Standard Definition Processor (SDP)	20	PLL	96
SD Luma Path	20	Digital Outputs (Both Data and Clocks)	96
SD Chroma Path.....	20	Digital Inputs	97
Sync Processing	21	XTAL and Load Capacitor Value Selection	97
VBI Data Recovery.....	21	Typical Circuit Connection.....	98
General Setup.....	21	Outline Dimensions	100
Color Controls	24	Ordering Guide	101
Clamp Operation.....	26		

REVISION HISTORY**3/05—Rev. A to Rev. B**

Changes to the Analog Specifications Section	8
Changes to Table 20 and Table 21	17
Changes to Table 27 and Table 28	19
Change to Table 50	25
Addition to the Clamp Operation Section.....	26
Changes to Figures 11	29
Changes to Figures 12, 13, 14	30
Changes to Chroma Filter Section	30
Deleted YPM Section and Renumbered Subsequent Tables	30
Changes to Figure 15	31
Change to the Luma Gain Section	32
Changes to Table 103 and Table 104.....	42
Deleted Table 172 and Renumbered Subsequent Tables.....	68
Changes to Table 176.....	71
Changes to Table 185.....	78
Changes to Table 192.....	83
Changes to Table 193.....	84
Changes to Table 194.....	85
Added XTAL and Load Capacitor Value Selection Section	97
Change to Figure 41	98

7/04—Rev. 0 to Rev. A

Addition to Applications List	1
Changes to Table 3	8
Changes to Table 5	8
Replaced Figure 3	9
Changes to Global Pin Control Section	16
Changes to Table 202	91
Changes to Table 203	92
Added package in Outline Dimensions Section	103
Changes to Ordering Guide.....	104

5/04—Revision 0: Initial Version

INTRODUCTION

The ADV7181 is a high quality, single chip, multiformat video decoder that automatically detects and converts PAL, NTSC, and SECAM standards in the form of composite, S-Video, and component video into a digital ITU-R BT.656 format.

The advanced, highly flexible digital output interface enables performance video decoding and conversion in line-locked clock-based systems. This makes the device ideally suited for a broad range of applications with diverse analog video characteristics, including tape-based sources, broadcast sources, security/surveillance cameras, and professional systems.

ANALOG FRONT END

The ADV7181 analog front end comprises three 9-bit ADCs that digitize the analog video signal before applying it to the standard definition processor. The analog front end employs differential channels to each ADC to ensure high performance in mixed-signal applications.

The front end also includes a 6-channel input mux that enables multiple video signals to be applied to the ADV7181. Current and voltage clamps are positioned in front of each ADC to ensure that the video signal remains within the range of the converter. Fine clamping of the video signals is performed downstream by digital fine clamping within the ADV7181. The ADCs are configured to run in 4× oversampling mode.

STANDARD DEFINITION PROCESSOR

The ADV7181 is capable of decoding a large selection of baseband video signals in composite, S-Video, and component formats. The video standards supported by the ADV7181 include PAL B/D/I/G/H, PAL60, PAL M, PAL N, PAL Nc, NTSC M/J, NTSC 4.43, and SECAM B/D/G/K/L. The ADV7181 can automatically detect the video standard and process it accordingly.

The ADV7181 has a 5-line, superadaptive, 2D comb filter that gives superior chrominance and luminance separation when decoding a composite video signal. This highly adaptive filter automatically adjusts its processing mode according to video standard and signal quality with no user intervention required. Video user controls such as brightness, contrast, saturation, and hue are also available within the ADV7181.

The ADV7181 implements a patented adaptive digital line-length tracking (ADLLT) algorithm to track varying video line lengths from sources such as a VCR. ADLLT enables the ADV7181 to track and decode poor quality video sources such as VCRs, noisy sources from tuner outputs, VCD players, and camcorders. The ADV7181 contains a chroma transient improvement (CTI) processor that sharpens the edge rate of chroma transitions, resulting in sharper vertical transitions.

The ADV7181 can process a variety of VBI data services such as closed captioning (CC), wide screen signaling (WSS), copy generation management system (CGMS), EDTV, Gemstar 1×/2×, and extended data service (XDS). The ADV7181 is fully Macrovision certified; detection circuitry enables Type I, II, and III protection levels to be identified and reported to the user. The decoder is also fully robust to all Macrovision signal inputs.

FUNCTIONAL BLOCK DIAGRAM

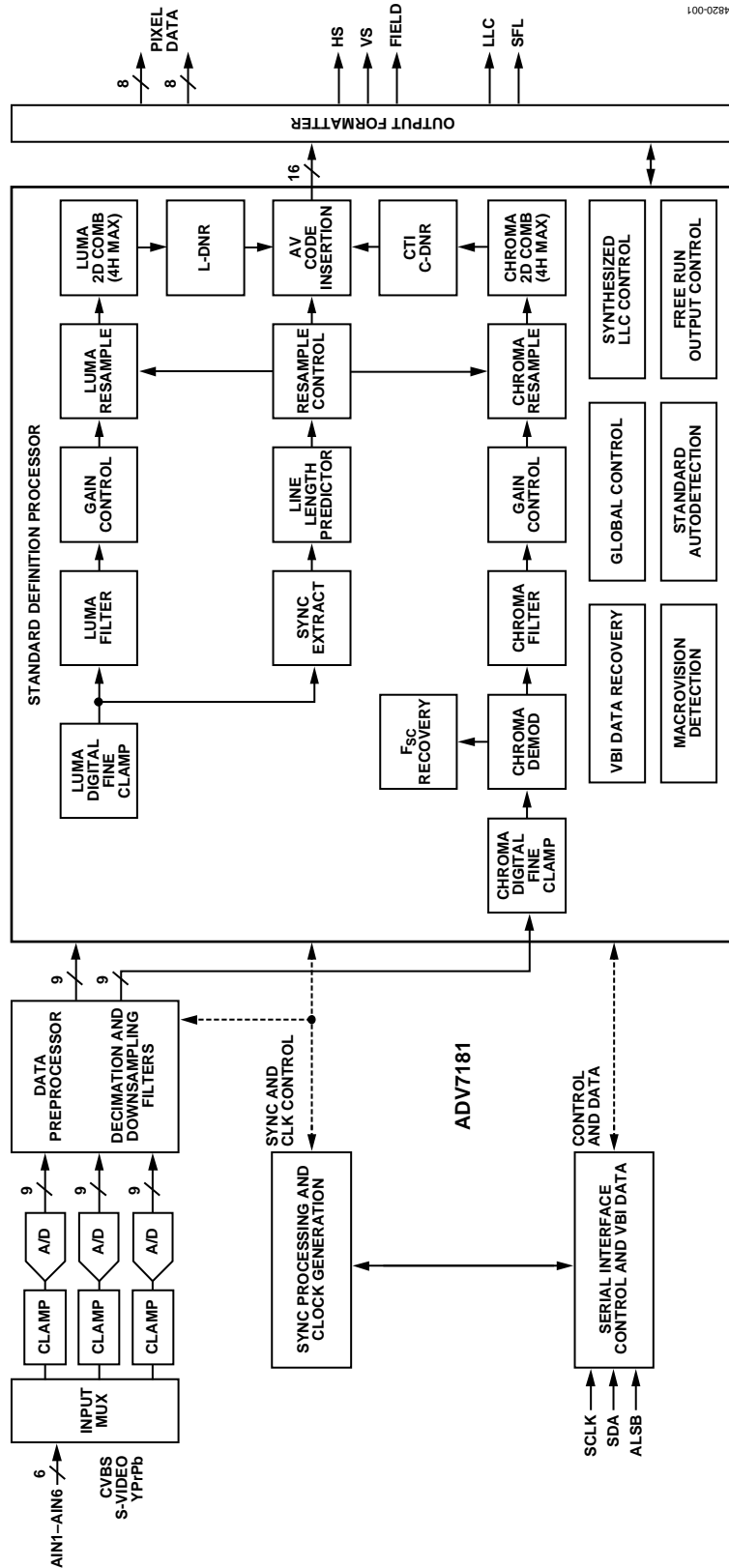

Figure 1.

SPECIFICATIONS

Temperature range: T_{MIN} to T_{MAX} , -40°C to $+85^{\circ}\text{C}$. The min/max specifications are guaranteed over this range.

ELECTRICAL CHARACTERISTICS

$A_{VDD} = 3.15\text{ V}$ to 3.45 V , $D_{VDD} = 1.65\text{ V}$ to 2.0 V , $D_{VDDIO} = 3.0\text{ V}$ to 3.6 V , $P_{VDD} = 1.65\text{ V}$ to 2.0 V ; operating temperature range, unless otherwise noted.

Table 1.

Parameter	Symbol	Test Conditions	Min	Typ	Max	Unit
STATIC PERFORMANCE						
Resolution (Each ADC)	N				9	Bits
Integral Nonlinearity	INL	BSL at 54 MHz		-0.475/+0.6	-1.5/+2	LSB
Differential Nonlinearity	DNL	BSL at 54 MHz		-0.25/+0.5	-0.7/+2	LSB
DIGITAL INPUTS						
Input High Voltage	V_{IH}		2			V
Input Low Voltage	V_{IL}				0.8	V
Input Current	I_{IN}	Pin 29	-50		+50	μA
		All other pins	-10		+10	μA
Input Capacitance	C_{IN}				10	pF
DIGITAL OUTPUTS						
Output High Voltage	V_{OH}	$I_{SOURCE} = 0.4\text{ mA}$	2.4			V
Output Low Voltage	V_{OL}	$I_{SINK} = 3.2\text{ mA}$			0.4	V
High Impedance Leakage Current	I_{LEAK}				10	μA
Output Capacitance	C_{OUT}				20	pF
POWER REQUIREMENTS¹						
Digital Core Power Supply	D_{VDD}		1.65	1.8	2	V
Digital I/O Power Supply	D_{VDDIO}		3.0	3.3	3.6	V
PLL Power Supply	P_{VDD}		1.65	1.8	2.0	V
Analog Power Supply	A_{VDD}		3.15	3.3	3.45	V
Digital Core Supply Current	I_{DVDD}			80		mA
Digital I/O Supply Current	I_{DVDDIO}			2		mA
PLL Supply Current	I_{PVDD}			10.5		mA
Analog Supply Current	I_{AVDD}	CVBS input ² YPrPb input ³		85		mA
				180		mA
Power-Down Current	I_{PWRDN}			1.5		mA
Power-Up Time	t_{PWRUP}			20		ms

¹ Guaranteed by characterization.

² ADC1 and ADC2 powered down.

³ All three ADCs powered on.

VIDEO SPECIFICATIONS

Guaranteed by characterization. $V_{DD} = 3.15\text{ V to }3.45\text{ V}$, $D_{VDD} = 1.65\text{ V to }2.0\text{ V}$, $D_{VDDIO} = 3.0\text{ V to }3.6\text{ V}$, $P_{VDD} = 1.65\text{ V to }2.0\text{ V}$; operating temperature range, unless otherwise noted.

Table 2.

Parameter	Symbol	Test Conditions	Min	Typ	Max	Unit
NONLINEAR SPECIFICATIONS						
Differential Phase	DP	CVBS I/P, modulate 5-step		0.6	0.7	°
Differential Gain	DG	CVBS I/P, modulate 5-step		0.6	0.7	%
Luma Nonlinearity	LNL	CVBS I/P, 5-step		0.6	0.7	%
NOISE SPECIFICATIONS						
SNR Unweighted		Luma ramp		54		dB
		Luma flat field		58		dB
Analog Front End Crosstalk				60		dB
LOCK TIME SPECIFICATIONS						
Horizontal Lock Range			-5		+5	%
Vertical Lock Range			40		70	Hz
Fsc Subcarrier Lock Range				±1.3		kHz
Color Lock In Time				60		Lines
Sync Depth Range			20		200	%
Color Burst Range			5		200	%
Vertical Lock Time				2		Fields
Autodetection Switch Speed				100		lines
CHROMA SPECIFICATIONS						
Hue Accuracy	HUE			1		°
Color Saturation Accuracy	CL_AC			1		%
Color AGC Range			5		400	%
Chroma Amplitude Error				0.5		%
Chroma Phase Error				0.5		°
Chroma Luma Intermodulation				0.2		%
LUMA SPECIFICATIONS						
Luma Brightness Accuracy		CVBS, 1 V I/P		1		%
Luma Contrast Accuracy		CVBS, 1 V I/P		1		%

ADV7181

TIMING SPECIFICATIONS

Guaranteed by characterization. $A_{VDD} = 3.15\text{ V to }3.45\text{ V}$, $D_{VDD} = 1.65\text{ V to }2.0\text{ V}$, $D_{VDDIO} = 3.0\text{ V to }3.6\text{ V}$, $P_{VDD} = 1.65\text{ V to }2.0\text{ V}$; operating temperature range, unless otherwise noted.

Table 3.

Parameter	Symbol	Test Conditions	Min	Typ	Max	Unit
SYSTEM CLOCK AND CRYSTAL						
Nominal Frequency				27.00		MHz
Frequency Stability					±50	ppm
I ² C PORT						
SCLK Frequency					400	kHz
SCLK Min Pulse Width High	t_1		0.6			μs
SCLK Min Pulse Width Low	t_2		1.3			μs
Hold Time (Start Condition)	t_3		0.6			μs
Setup Time (Start Condition)	t_4		0.6			μs
SDA Setup Time	t_5		100			ns
SCLK and SDA Rise Time	t_6				300	ns
SCLK and SDA Fall Time	t_7				300	ns
Setup Time for Stop Condition	t_8			0.6		μs
RESET FEATURE						
Reset Pulse Width			5			ms
CLOCK OUTPUTS						
LLC1 Mark Space Ratio	$t_9:t_{10}$		45:55		55:45	% Duty Cycle
DATA AND CONTROL OUTPUTS						
Data Output Transitional Time	t_{11}	Negative clock edge to start of valid data. ($t_{ACCESS} = t_{10} - t_{11}$)			6	ns
Data Output Transitional Time	t_{12}	End of valid data to negative clock edge. ($t_{HOLD} = t_9 + t_{12}$)			0.6	ns

ANALOG SPECIFICATIONS

Guaranteed by characterization. At $A_{VDD} = 3.15\text{ V to }3.45\text{ V}$, $D_{VDD} = 1.65\text{ V to }2.0\text{ V}$, $D_{VDDIO} = 3.0\text{ V to }3.6\text{ V}$, $P_{VDD} = 1.65\text{ V to }2.0\text{ V}$; operating temperature range, unless otherwise noted. Recommended analog input video signal range: 0.5 V – 1.6 V, typically 1 V p-p.

Table 4.

Parameter	Symbol	Test Conditions	Min	Typ	Max	Unit
CLAMP CIRCUITRY						
External Clamp Capacitor		Clamps switched off		0.1		μF
Input Impedance				10		MΩ
Large Clamp Source Current				0.75		mA
Large Clamp Sink Current				0.75		mA
Fine Clamp Source Current				60		μA
Fine Clamp Sink Current				60		μA

THERMAL SPECIFICATIONS

Table 5.

Parameter	Symbol	Test Conditions	Min	Typ	Max	Unit
THERMAL CHARACTERISTICS						
Junction-to-Ambient Thermal Resistance (Still Air)	θ_{JA}	4-layer PCB with solid ground plane, 64-lead LFCSP		45.5		°C/W
Junction-to-Case Thermal Resistance	θ_{JC}	4-layer PCB with solid ground plane, 64-lead LFCSP		9.2		°C/W
Junction-to-Ambient Thermal Resistance (Still Air)	θ_{JA}	4-layer PCB with solid ground plane, 64-lead LQFP		47		°C/W
Junction-to-Case Thermal Resistance	θ_{JC}	4-layer PCB with solid ground plane, 64-lead LQFP		11.1		°C/W

TIMING DIAGRAMS

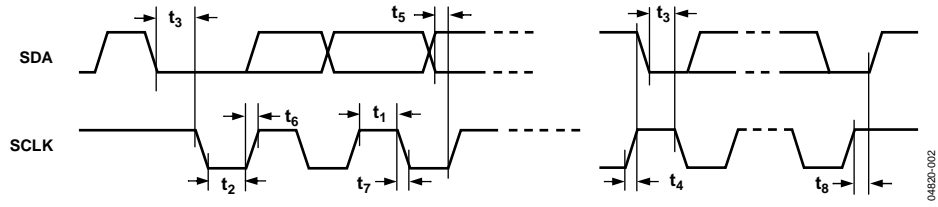

Figure 2. I²C Timing

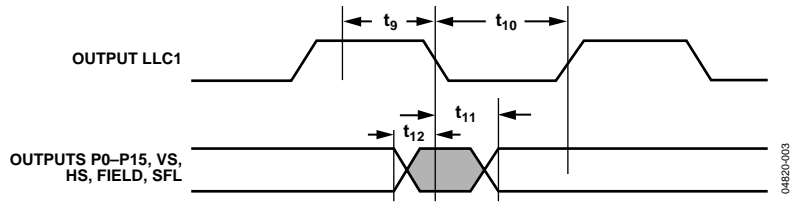

Figure 3. Pixel Port and Control Output Timing

ABSOLUTE MAXIMUM RATINGS

Table 6.

Parameter	Rating
A_{VDD} to GND	4 V
A_{VDD} to AGND	4 V
D_{VDD} to DGND	2.2 V
P_{VDD} to AGND	2.2 V
D_{VDDIO} to DGND	4 V
D_{VDDIO} to A_{VDD}	-0.3 V to +0.3 V
P_{VDD} to D_{VDD}	-0.3 V to +0.3 V
$D_{VDDIO} - P_{VDD}$	-0.3 V to +2 V
$D_{VDDIO} - D_{VDD}$	-0.3 V to +2 V
$A_{VDD} - P_{VDD}$	-0.3 V to +2 V
$A_{VDD} - D_{VDD}$	-0.3 V to +2 V
Digital Inputs Voltage to DGND	-0.3 V to $D_{VDDIO} + 0.3$ V
Digital Output Voltage to DGND	-0.3 V to $D_{VDDIO} + 0.3$ V
Analog Inputs to AGND	AGND - 0.3 V to $A_{VDD} + 0.3$ V
Maximum Junction Temperature (T_J max)	150°C
Storage Temperature Range	-65°C to +150°C
Infrared Reflow Soldering (20 s)	260°C

Stresses above those listed under Absolute Maximum Ratings may cause permanent damage to the device. This is a stress rating only; functional operation of the device at these or any other conditions above those indicated in the operational sections of this specification is not implied. Exposure to absolute maximum rating conditions for extended periods may affect device reliability.

ESD CAUTION

ESD (electrostatic discharge) sensitive device. Electrostatic charges as high as 4000 V readily accumulate on the human body and test equipment and can discharge without detection. Although this product features proprietary ESD protection circuitry, permanent damage may occur on devices subjected to high energy electrostatic discharges. Therefore, proper ESD precautions are recommended to avoid performance degradation or loss of functionality.



PIN CONFIGURATION AND FUNCTION DESCRIPTIONS

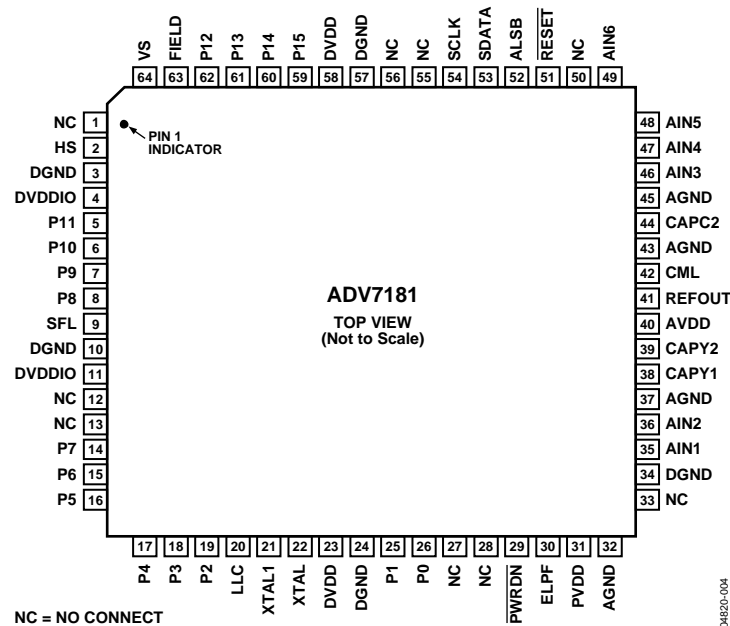

Figure 4. 64-Lead LFCSP/LQFP Pin Configuration

Table 7. Pin Function Descriptions

Pin No.	Mnemonic	Type	Function
3, 10, 24, 34, 57	DGND	G	Digital Ground.
32, 37, 43, 45	AGND	G	Analog Ground.
4, 11	DVDDIO	P	Digital I/O Supply Voltage (3.3 V).
23, 58	DVDD	P	Digital Core Supply Voltage (1.8 V).
40	AVDD	P	Analog Supply Voltage (3.3 V).
31	PVDD	P	PLL Supply Voltage (1.8 V).
35, 36, 46–49	AIN1–AIN6	I	Analog Video Input Channels.
1, 12, 13, 27, 28, 33, 50, 55, 56	NC		No Connect Pins.
26, 25, 19, 18, 17, 16, 15, 14, 8, 7, 6, 5, 62, 61, 60, 59	P0–P15	O	Video Pixel Output Port.
2	HS	O	Horizontal Synchronization Output Signal.
64	VS	O	Vertical Synchronization Output Signal.
63	FIELD	O	Field Synchronization Output Signal.
53	SDA	I/O	I ² C Port Serial Data Input/Output Pin.
54	SCLK	I	I ² C Port Serial Clock Input (Max Clock Rate of 400 kHz).
52	ALSB	I	This pin selects the I ² C address for the ADV7181. ALSB set to a Logic 0 sets the address for a write as 0x40; for ALSB set to a logic high, the address selected is 0x42.
51	RESET	I	System Reset Input, Active Low. A minimum low reset pulse width of 5 ms is required to reset the ADV7181 circuitry.
20	LLC	O	This is a line-locked output clock for the pixel data output by the ADV7181. Nominally 27 MHz, but varies up or down according to video line length.
22	XTAL	I	This is the input pin for the 27 MHz crystal, or can be overdriven by an external 3.3 V, 27 MHz clock oscillator source. In crystal mode, the crystal must be a fundamental crystal.

ADV7181

Pin No.	Mnemonic	Type	Function
21	XTAL1	O	This pin should be connected to the 27 MHz crystal or left as a no connect if an external 3.3 V, 27 MHz clock oscillator source is used to clock the ADV7181. In crystal mode, the crystal must be a fundamental crystal.
29	$\overline{\text{PWRDN}}$	I	A logic low on this pin places the ADV7181 in a power-down mode. Refer to the I2C Control Register Map section for more options on power-down modes for the ADV7181.
30	ELPF	I	The recommended external loop filter must be connected to this ELPF pin, as shown in Figure 42.
9	SFL	O	Subcarrier Frequency Lock. This pin contains a serial output stream that can be used to lock the subcarrier frequency when this decoder is connected to any Analog Devices digital video encoder.
41	REFOUT	O	Internal Voltage Reference Output. Refer to Figure 42 for a recommended capacitor network for this pin.
42	CML	O	Common-Mode Level for the Internal ADCs. Refer to Figure 42 for a recommended capacitor network for this pin.
38, 39	CAPY1, CAPY2	I	ADC's Capacitor Network. Refer to Figure 42 for a recommended capacitor network for this pin.
44	CAPC2	I	ADC's Capacitor Network. Refer to Figure 42 for a recommended capacitor network for this pin.

ANALOG FRONT END

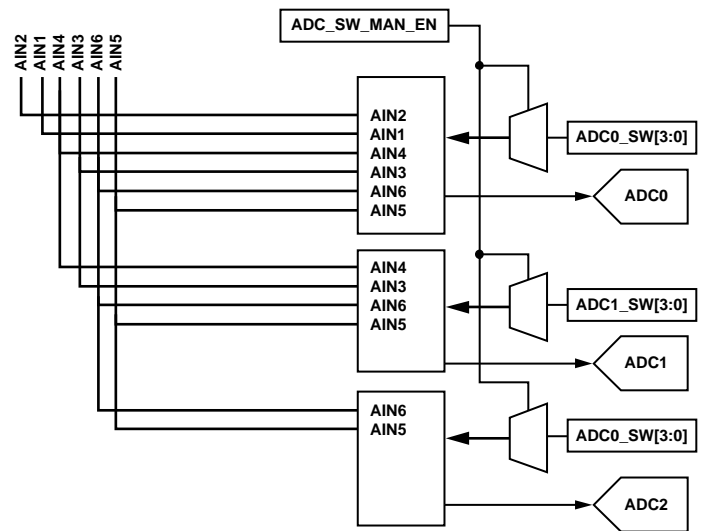

Figure 5. Internal Pin Connections

There are two key steps to configure the ADV7181 to correctly decode the input video. Descriptions of these steps follow.

- The analog input muxing section must be configured to correctly route the video from the analog input pins to the correct set of ADCs.
- The standard definition processor block, which decodes the digital data, should be configured to process either CVBS, YC, or YPrPb.

ANALOG INPUT MUXING

The ADV7181 has an integrated analog muxing section that allows more than one source of video signal to be connected to the decoder. Figure 5 outlines the overall structure of the input muxing provided in the ADV7181.

A maximum of six CVBS inputs can be connected and decoded by the ADV7181. As seen in the Pin Configuration and Function Description section, these analog input pins lie in close proximity to one another. This calls for a careful design of the PCB layout, for example, ground shielding between all signals routed through tracks that are physically close together. It is strongly recommended to connect any unused analog input pins to AGND to act as a shield.

SETADC_sw_man_en, Manual Input Muxing Enable, Address C4 [7]

ADC0_sw[3:0], ADC0 mux configuration, Address C3 [3:0]

ADC1_sw[3:0], ADC1 mux configuration, Address C3 [7:4]

ADC2_sw[3:0], ADC2 mux configuration, Address C4 [3:0]

To configure the ADV7181 analog muxing section, the user must select the analog input (AIN1–AIN6) that is to be processed by each ADC. SETADC_sw_man_en must be set to 1 to enable the muxing blocks to be configured. The three mux sections are controlled by the signal buses ADC0/1/2_sw[3:0]. Table 8 explains the control words used.

The input signal that contains the timing information (H/V syncs) must be processed by ADC0. For example, in YC input configuration, ADC0 should be connected to the Y channel and ADC1 to the C channel. In cases where one or more ADCs are not used to process video, for example, CVBS input, the idle ADCs should be powered down, (see the ADC Power-Down Control section).

Restrictions are imposed on the channel routing by the analog signal routing inside the IC; every input pin cannot be routed to each ADC. Refer to Table 8 for an overview on the routing capabilities inside the chip.

ADV7181

Table 8. Manual Mux Settings for All ADCs

SETADC_sw_man_en = 1					
ADC0_sw[3:0]	ADC0 Connected To:	ADC1_sw[3:0]	ADC1 Connected To:	ADC2_sw[3:0]	ADC2 Connected To:
0000	No Connection	0000	No Connection	0000	No Connection
0001	AIN2	0001	No Connection	0001	No Connection
0010	No Connection	0010	No Connection	0010	No Connection
0011	No Connection	0011	No Connection	0011	No Connection
0100	AIN4	0100	AIN4	0100	No Connection
0101	AIN6	0101	AIN6	0101	AIN6
0110	No Connection	0110	No Connection	0110	No Connection
0111	No Connection	0111	No Connection	0111	No Connection
1000	No Connection	1000	No Connection	1000	No Connection
1001	AIN1	1001	No Connection	1001	No Connection
1010	No Connection	1010	No Connection	1010	No Connection
1011	No Connection	1011	No Connection	1011	No Connection
1100	AIN3	1100	AIN3	1100	No Connection
1101	AIN5	1101	AIN5	1101	AIN5
1110	No Connection	1110	No Connection	1110	No Connection
1111	No Connection	1111	No Connection	1111	No Connection

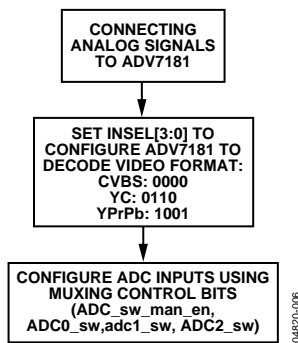

Figure 6. Input Muxing Overview

INSEL[3:0] Input Selection, Address 0x00 [3:0]

The INSEL bits allow the user to select the input format. It configures the Standard Definition Processor core to process CVBS (Comp), S-Video (Y/C), or Component (YPbPr) format.

Table 9. Standard Definition Processor Format Selection, INSEL[3:0]

INSEL[3:0]	Video Format
0000	Composite
0110	YC
1001	YPrPb

GLOBAL CONTROL REGISTERS

Register control bits listed in this section affect the whole chip.

POWER-SAVE MODES

Power-Down

PDBP, Address 0x0F [2]

There are two ways to shut down the digital core of the ADV7181: a pin (PWRDN) and a bit (PWRDN see below). The PDBP controls which of the two has the higher priority. The default is to give the pin (PWRDN) priority. This allows the user to have the ADV7181 powered down by default.

Table 10. PDBP Function

PDBP	Description
0 (default)	Digital core power controlled by the PWRDN pin (bit is disregarded).
1	Bit has priority (pin is disregarded).

PWRDN, Address 0x0F [5]

Setting the PWRDN bit switches the ADV7181 into a chip-wide power-down mode. The power-down stops the clock from entering the digital section of the chip, thereby freezing its operation. No I²C bits are lost during power-down. The PWRDN bit also affects the analog blocks and switches them into low current modes. The I²C interface itself is unaffected, and remains operational in power-down mode.

The ADV7181 leaves the power-down state if the PWRDN bit is set to 0 (via I²C), or if the overall part is reset using the RESET pin.

PDBP must be set to 1 for the PWRDN bit to power down the ADV7181.

Table 11. PWRDN Function

PWRDN	Description
0 (default)	Chip operational.
1	ADV7181 in chip-wide power-down.

ADC Power-Down Control

The ADV7181 contains three 9-bit ADCs (ADC 0, ADC 1, and ADC 2). If required, it is possible to power down each ADC individually.

When should the ADCs be powered down?

- CVBS mode. ADC 1 and ADC 2 should be powered down to save on power consumption.
- S-Video mode. ADC 2 should be powered down to save on power consumption.

PWRDN_ADC_0, Address 0x3A [3]

Table 12. PWRDN_ADC_0 Function

PWRDN_ADC_0	Description
0 (default)	ADC normal operation.
1	Power down ADC 0.

PWRDN_ADC_1, Address 0x3A [2]

Table 13. PWRDN_ADC_1 Function

PWRDN_ADC_1	Description
0 (default)	ADC normal operation.
1	Power down ADC 1.

PWRDN_ADC_2, Address 0x3A [1]

Table 14. PWRDN_ADC_2 Function

PWRDN_ADC_2	Description
0 (default)	ADC normal operation.
1	Power down ADC 2.

RESET CONTROL

Chip Reset (RES), Address 0x0F [7]

Setting this bit, equivalent to controlling the RESET pin on the ADV7181, issues a full chip reset. All I²C registers are reset to their default values. (Some register bits do not have a reset value specified. They keep their last written value. Those bits are marked as having a reset value of x in the register table.) After the reset sequence, the part immediately starts to acquire the incoming video signal.

Notes

- After setting the RES bit (or initiating a reset via the pin), the part returns to the default mode of operation with respect to its primary mode of operation. All I²C bits are loaded with their default values, making this bit self-clearing.
- Executing a software reset takes approximately 2 ms. However, it is recommended to wait 5 ms before further I²C writes are performed.
- The I²C master controller receives a no acknowledge condition on the ninth clock cycle when chip reset is implemented. See the MPU Port Description section.

Table 15. RES Function

RES	Description
0 (default)	Normal operation.
1	Start reset sequence.

GLOBAL PIN CONTROL Three-State Output Drivers

TOD, Address 0x03 [6]

This bit allows the user to three-state the output drivers of the ADV7181.

Upon setting the TOD bit, the P15–P0, HS, VS, FIELD, and SFL pins are three-stated.

The timing pins (HS/VS/FIELD) can be forced active via the TIM_OE bit. For more information on three-state control, refer to the following sections:

- Three-State LLC Driver
- Timing Signals Output Enable

Individual drive strength controls are provided via the DR_STR_XX bits.

Table 16. TOD Function

TOD	Description
0 (default)	Output drivers enabled.
1	Output drivers three-stated.

Three-State LLC Driver

TRI_LLC, Address 0x0E [6]

This bit allows the output drivers for the LLC pin of the ADV7181 to be three-stated. For more information on three-state control, refer to the following sections:

- Three-State Output Drivers
- Timing Signals Output Enable

Individual drive strength controls are provided via the DR_STR_XX bits.

Table 17. TRI_LLC Function

TRI_LLC	Description
0 (default)	LLC pin drivers working according to the DR_STR_C[1:0] setting (pin enabled).
1	LLC pin drivers three-stated.

Timing Signals Output Enable

TIM_OE, Address 0x04 [3]

The TIM_OE bit should be regarded as an addition to the TOD bit. Setting it high forces the output drivers for HS, VS, and FIELD into the active (that is, driving) state even if the TOD bit is set. If set to low, the HS, VS, and FIELD pins are three-stated depending on the TOD bit. This functionality is useful if the decoder is to be used as a timing generator only. This may be the case if only the timing signals are to be extracted from an incoming signal, or if the part is in free-run mode where a separate chip can output, for instance, a company logo.

For more information on three-state control, refer to the following sections:

- Three-State Output Drivers
- Three-State LLC Driver

Individual drive strength controls are provided via the DR_STR_XX bits.

Table 18. TIM_OE Function

TIM_OE	Description
0 (default)	HS, VS, FIELD three-stated according to the TOD bit.
1	HS, VS, FIELD are forced active all the time. The DR_STR_S[1:0] setting determines drive strength.

Drive Strength Selection (Data)

DR_STR[1:0] Address 0x04 [5:4]

For EMC and crosstalk reasons, it may be desirable to strengthen or weaken the drive strength of the output drivers. The DR_STR[1:0] bits affect the P[15:0] output drivers.

For more information on three-state control, refer to the following sections:

- Drive Strength Selection (Clock)
- Drive Strength Selection (Sync)

Table 19. DR_STR Function

DR_STR[1:0]	Description
00	Low drive strength (1×).
01 (default)	Medium low drive strength (2×).
10	Medium high drive strength (3×).
11	High drive strength (4×).

Drive Strength Selection (Clock)**DR_STR_C[1:0] Address 0x0E [3:2]**

The DR_STR_C[1:0] bits can be used to select the strength of the clock signal output driver (LLC pin). For more information, refer to the following sections:

- Drive Strength Selection (Sync)
- Drive Strength Selection (Data)

Table 20. DR_STR_C Function

DR_STR_C[1:0]	Description
00	Low drive strength (1×).
01 (default)	Medium low drive strength (2×).
10	Medium high drive strength (3×).
11	High drive strength (4×).

Drive Strength Selection (Sync)**DR_STR_S[1:0] Address 0x0E [1:0]**

The DR_STR_S[1:0] bits allow the user to select the strength of the synchronization signals with which HS, VS, and F are driven. For more information, refer to the following sections:

- Drive Strength Selection (Clock)
- Drive Strength Selection (Data)

Table 21. DR_STR_S Function

DR_STR_S[1:0]	Description
00	Low drive strength (1×).
01 (default)	Medium low drive strength (2×).
10	Medium high drive strength (3×).
11	High drive strength (4×).

Enable Subcarrier Frequency Lock Pin**EN_SFL_PIN Address 0x04 [1]**

The EN_SFL_PIN bit enables the output of subcarrier lock information (also known as GenLock) from the ADV7181 to an encoder in a decoder-encoder back-to-back arrangement.

Table 22. EN_SFL_PIN

EN_SFL_PIN	Description
0 (default)	Subcarrier frequency lock output is disabled.
1	Subcarrier frequency lock information is presented on the SFL pin.

Polarity LLC Pin**PCLK Address 0x37 [0]**

The polarity of the clock that leaves the ADV7181 via the LLC pin can be inverted using the PCLK bit.

Changing the polarity of the LLC clock output may be necessary to meet the setup-and-hold time expectations of follow-on chips.

Table 23. PCLK Function

PCLK	Description
0	Invert LLC output polarity.
1 (default)	LLC output polarity normal (as per the Timing Diagrams).

GLOBAL STATUS REGISTERS

Four registers provide summary information about the video decoder. The IDENT register allows the user to identify the revision code of the ADV7181. The other three registers contain status bits from the ADV7181.

IDENTIFICATION

IDENT[7:0] Address 0x11 [7:0]

Provides identification of the revision of the ADV7181. Review the list of IDENT code readback values for the various versions shown in Table 24.

Table 24. IDENT Function

IDENT[7:0]	Description
0x0D	ADV7181-ES1
0x0E	ADV7181-ES2
0x0F or 0x10	ADV7181-FT
0x11	ADV7181 (Version 2)

STATUS 1

STATUS_1[7:0] Address 0x10 [7:0]

This read-only register provides information about the internal status of the ADV7181.

See CIL[2:0] Count Into Lock, Address 0x51 [2:0] and COL[2:0] Count Out of Lock, Address 0x51 [5:3] for information on the timing.

Table 26. STATUS 1 Function

STATUS 1 [7:0]	Bit Name	Description
0	IN_LOCK	In lock (right now).
1	LOST_LOCK	Lost lock (since last read of this register).
2	FSC_LOCK	Fsc locked (right now).
3	FOLLOW_PW	AGC follows peak white algorithm.
4	AD_RESULT.0	Result of autodetection.
5	AD_RESULT.1	Result of autodetection.
6	AD_RESULT.2	Result of autodetection.
7	COL_KILL	Color kill active.

Depending on the setting of the FSCLE bit, the Status[0] and Status[1] are based solely on horizontal timing info or on the horizontal timing and lock status of the color subcarrier. See the FSCLE Fsc Lock Enable, Address 0x51 [7] section.

Autodetection Result

AD_RESULT[2:0] Address 0x10 [6:4]

The AD_RESULT[2:0] bits report back on the findings from the autodetection block. Consult the General Setup section for more information on enabling the autodetection block, and the Autodetection of SD Modes section to find out how to configure it.

Table 25. AD_RESULT Function

AD_RESULT[2:0]	Description
000	NTSM-MJ
001	NTSC-443
010	PAL-M
011	PAL-60
100	PAL-BGHID
101	SECAM
110	PAL-Combination N
111	SECAM 525

STATUS 2

STATUS_2[7:0], Address 0x12 [7:0]

Table 27. STATUS 2 Function

STATUS 2 [7:0]	Bit Name	Description
0	MVCS DET	Detected Macrovision color striping.
1	MVCS T3	Macrovision color striping protection. Conforms to Type 3 (if high), and Type 2 (if low).
2	MV_PS DET	Detected Macrovision pseudo sync pulses.
3	MV_AGC DET	Detected Macrovision AGC pulses.
4	LL_NSTD	Line length is nonstandard.
5	FSC_NSTD	Fsc frequency is nonstandard.
6	Reserved	
7	Reserved	

STATUS 3

STATUS_3[7:0], Address 0x13 [7:0]

Table 28. STATUS 3 Function

STATUS 3 [7:0]	Bit Name	Description
0	INST_HLOCK	Horizontal lock indicator (instantaneous).
1	Reserved	
2	Reserved	
3	Reserved	
4	FREE_RUN_ACT	ADV7181 outputs a blue screen (see the DEF_VAL_AUTO_EN Default Value Automatic Enable, Address 0x0C [1] section).
5	STD_FLD_LEN	Field length is correct for currently selected video standard.
6	INTERLACED	Interlaced video detected (field sequence found).
7	PAL_SW_LOCK	Reliable sequence of swinging bursts detected.

STANDARD DEFINITION PROCESSOR (SDP)

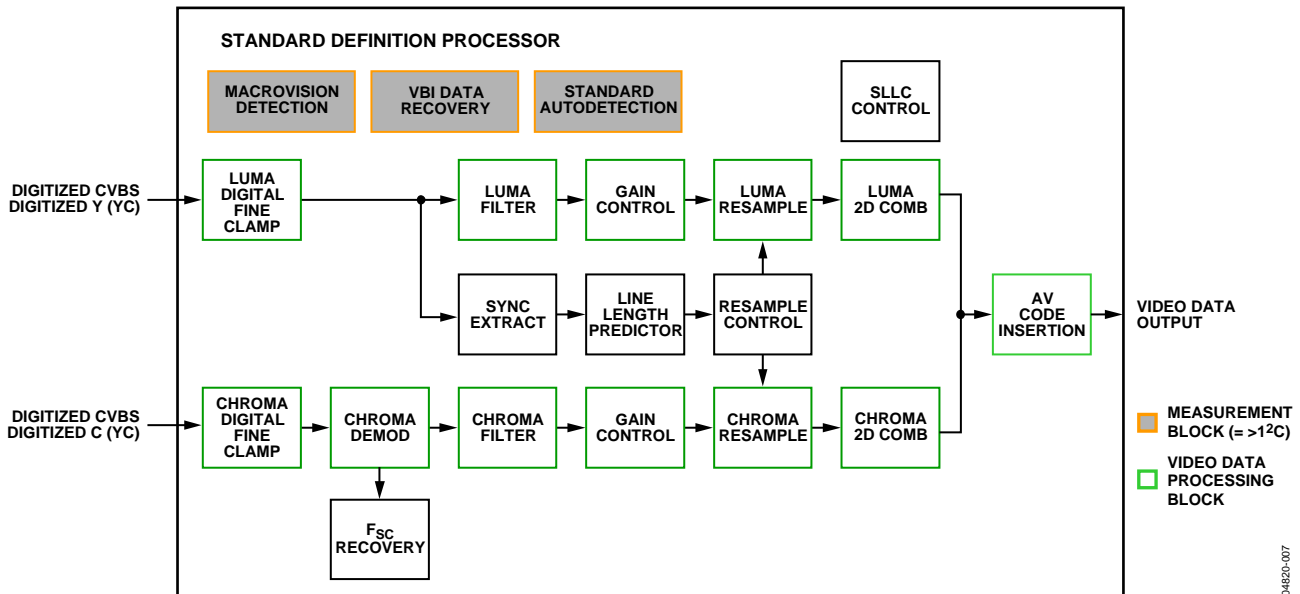

Figure 7. Block Diagram of the Standard Definition Processor

A block diagram of the ADV7181's standard definition processor is shown in Figure 7.

The SDP block can handle standard definition video in CVBS, YC, and YPrPb formats. It can be divided into a luminance and chrominance path. If the input video is of a composite type (CVBS), both processing paths are fed with the CVBS input.

SD LUMA PATH

The input signal is processed by the following blocks:

- Digital Fine Clamp. This block uses a high precision algorithm to clamp the video signal.
- Luma Filter Block. This block contains a luma decimation filter (YAA) with a fixed response, and some shaping filters (YSH) that have selectable responses.
- Luma Gain Control. The automatic gain control (AGC) can operate on a variety of different modes, including gain-based on the depth of the horizontal sync pulse, peak white mode, and fixed manual gain.
- Luma Resample. To correct for line-length errors as well as dynamic line-length changes, the data is digitally resampled.
- Luma 2D Comb. The two-dimensional comb filter provides YC separation.
- AV Code Insertion. At this point, the decoded luma (Y) signal is merged with the retrieved chroma values. AV codes (as per ITU-R. BT-656) can be inserted.

SD CHROMA PATH

The input signal is processed by the following blocks:

- Digital Fine Clamp. This block uses a high precision algorithm to clamp the video signal.
- Chroma Demodulation. This block uses a color subcarrier (Fsc) recovery unit to regenerate the color subcarrier for any modulated chroma scheme. The demodulation block then performs an AM demodulation for PAL and NTSC, and an FM demodulation for SECAM.
- Chroma Filter Block. This block contains a chroma decimation filter (CAA) with a fixed response, and some shaping filters (CSH) that have selectable responses.
- Gain Control. Automatic gain control (AGC) can operate on several different modes, including gain based on the color subcarrier's amplitude, gain based on the depth of the horizontal sync pulse on the luma channel, or fixed manual gain.
- Chroma Resample. The chroma data is digitally resampled to keep it perfectly aligned with the luma data. The resampling is done to correct for static and dynamic line-length errors of the incoming video signal.
- Chroma 2D Comb. The two-dimensional, 5-line, superadaptive comb filter provides high quality YC separation in case the input signal is CVBS.
- AV Code Insertion. At this point, the demodulated chroma (Cr and Cb) signal is merged with the retrieved luma values. AV codes (as per ITU-R. BT-656) can be inserted.

SYNC PROCESSING

The ADV7181 extracts syncs embedded in the video data stream. There is currently no support for external HS/VS inputs. The sync extraction has been optimized to support imperfect video sources, for example, videocassette recorders with head switches. The actual algorithm used employs a coarse detection based on a threshold crossing followed by a more detailed detection using an adaptive interpolation algorithm. The raw sync information is sent to a line-length measurement and prediction block. The output is then used to drive the digital resampling section to ensure that the ADV7181 outputs 720 active pixels per line.

The sync processing on the ADV7181 includes two specialized postprocessing blocks that filter and condition the raw sync information retrieved from the digitized analog video.

- VSYNC processor. This block provides extra filtering of the detected VSYNCS to give improved vertical lock.
- HSYNC processor. The HSYNC processor is designed to filter incoming HSYNCS that have been corrupted by noise, providing much improved performance for video signals with stable time base but poor SNR.

VBI DATA RECOVERY

The ADV7181 can retrieve the following information from the input video:

- Wide-screen signaling (WSS)
- Copy generation management system (CGMS)
- Closed caption (CC)
- Macrovision protection presence
- EDTV data
- Gemstar-compatible data slicing

The ADV7181 is capable of automatically detecting the incoming video standard with respect to color subcarrier frequency, field rate, and line rate.

It can configure itself to support PAL-BGHID, PAL-M/N, PAL-combination N, NTSC-M, NTSC-J, SECAM 50 Hz/60 Hz, NTSC4.43, and PAL60.

GENERAL SETUP

Video Standard Selection

The VID_SEL[3:0] register allows the user to force the digital core into a specific video standard. Under normal circumstances, this should not be necessary. The VID_SEL[3:0] bits default to an autodetection mode that supports PAL, NTSC, SECAM, and variants thereof.

Refer to the Autodetection of SD Modes section for more information on the autodetection system.

Autodetection of SD Modes

In order to guide the autodetect system of the ADV7181, individual enable bits are provided for each of the supported video standards. Setting the relevant bit to 0 inhibits the standard from being detected automatically. Instead, the system picks the closest of the remaining enabled standards. The results of the autodetection can be read back via the status registers. See the Global Status Registers section for more information.

Table 29. VID_SEL Function

VID_SEL[3:0] Address 0x00 [7:4]	Description
0000 (default)	Autodetect (PAL BGHID) <-> NTSC J (no pedestal), SECAM.
0001	Autodetect (PAL BGHID) <-> NTSC M (pedestal), SECAM.
0010	Autodetect (PAL N) <-> NTSC J (no pedestal), SECAM.
0011	Autodetect (PAL N) <-> NTSC M (pedestal), SECAM.
0100	NTSC J (1)
0101	NTSC M (1).
0110	PAL60.
0111	NTSC4.43 (1).
1000	PAL BGHID.
1001	PAL N (= PAL BGHID (with pedestal)).
1010	PAL M (without pedestal).
1011	PAL M.
1100	PAL combination N.
1101	PAL combination N (with pedestal).
1110	SECAM.
1111	SECAM (with pedestal).

AD_SEC525_EN Enable Autodetection of SECAM 525

Line Video, Address 0x07 [7]

Table 30. AD_SEC525_EN Function

AD_SEC525_EN	Description
0 (default)	Disable the autodetection of a 525-line system with a SECAM style, FM-modulated color component.
1	Enable the detection.

AD_SECAM_EN Enable Autodetection of SECAM,

Address 0x07 [6]

Table 31. AD_SECAM_EN Function

AD_SECAM_EN	Description
0	Disable the autodetection of SECAM.
1 (default)	Enable the detection.

AD_N443_EN Enable Autodetection of NTSC443,

Address 0x07 [5]

Table 32. AD_N443_EN Function

AD_N443_EN	Description
0	Disable the autodetection of NTSC style systems with a 4.43 MHz color subcarrier.
1 (default)	Enable the detection.

AD_P60_EN Enable Autodetection of PAL60,

Address 0x07 [4]

Table 33. AD_P60_EN Function

AD_P60_EN	Description
0	Disable the autodetection of PAL systems with a 60 Hz field rate.
1 (default)	Enable the detection.

AD_PALN_EN Enable Autodetection of PAL N,

Address 0x07 [3]

Table 34. AD_PALN_EN Function

AD_PALN_EN	Description
0	Disable the detection of the PAL N standard.
1 (default)	Enable the detection.

AD_PALM_EN Enable Autodetection of PAL M,

Address 0x07 [2]

Table 35. AD_PALM_EN Function

AD_PALM_EN	Description
0	Disable the autodetection of PAL M.
1 (default)	Enable the detection.

AD_NTSC_EN Enable Autodetection of NTSC,

Address 0x07 [1]

Table 36. AD_NTSC_EN Function

AD_NTSC_EN	Description
0	Disable the detection of standard NTSC.
1 (default)	Enable the detection.

AD_PAL_EN Enable Autodetection of PAL,

Address 0x07 [0]

Table 37. AD_PAL_EN Function

AD_PAL_EN	Description
0	Disable the detection of standard PAL.
1 (default)	Enable the detection.

SFL_INV Subcarrier Frequency Lock Inversion

This bit controls the behavior of the PAL switch bit in the SFL (GenLock Telegram) data stream. It was implemented to solve some compatibility issues with video encoders. It solves two problems:

- The PAL switch bit is only meaningful in PAL. Some encoders (including Analog Devices encoders) also look at the state of this bit in NTSC.
- There was a design change in Analog Devices encoders from ADV717x to ADV719x. The older versions used the SFL (GenLock Telegram) bit directly, while the later ones invert the bit prior to using it. This is because the inversion compensated for the 1-line delay of an SFL (GenLock Telegram) transmission.

As a result:

- ADV717x encoders need the PAL switch bit in the SFL (GenLock Telegram) to be 1 for NTSC to work.
- ADV7190/ADV7191/ADV7194 encoders need the PAL switch bit in the SFL to be 0 to work in NTSC.

If the state of the PAL switch bit is wrong, a 180° phase shift occurs.

In a decoder/encoder back-to-back system in which SFL is used, this bit must be set up properly for the specific encoder used.

Table 38. SFL_INV Function

SFL_INV Address 0x41 [6]	Description
0	SFL-compatible with ADV7190/ADV7191/ADV7194 encoders.
1 (default)	SFL-compatible with ADV717x/ADV7173x encoders.

Lock Related Controls

Lock information is presented to the user through Bits [1:0] of the Status 1 register. See the STATUS_1[7:0] Address 0x10 [7:0] section. Figure 8 outlines the signal flow and the controls available to influence the way the lock status information is generated.

SRLS Select Raw Lock Signal, Address 0x51 [6]

Using the SRLS bit, the user can choose between two sources for determining the lock status (per Bits [1:0] in the Status 1 register).

- The time_win signal is based on a line-to-line evaluation of the horizontal synchronization pulse of the incoming video. It reacts quite quickly.
- The free_run signal evaluates the properties of the incoming video over several fields, and takes vertical synchronization information into account.

Table 39. SRLS Function

SRLS	Description
0 (default)	Select the free_run signal.
1	Select the time_win signal.

FSCLE Fsc Lock Enable, Address 0x51 [7]

The FSCLE bit allows the user to choose whether or not the status of the color subcarrier loop is taken into account when the overall lock status is determined and presented via Bits [1:0] in Status Register 1. This bit must be set to 0 when operating the ADV7181 in YPrPb component mode in order to generate a reliable HLOCK status bit.

Table 40. FSCLE Function

FSCLE	Description
0	Overall lock status only dependent on horizontal sync lock.
1 (default)	Overall lock status dependent on horizontal sync lock and Fsc Lock.

CIL[2:0] Count Into Lock, Address 0x51 [2:0]

CIL[2:0] determine the number of consecutive lines for which the into lock condition must be true before the system switches into the locked state, and reports this via Status 0 [1:0].

Table 41. CIL Function

CIL[2:0]	Description (Count Value in Lines of Video)
000	1
001	2
010	5
011	10
100 (default)	100
101	500
110	1000
111	10000

COL[2:0] Count Out of Lock, Address 0x51 [5:3]

COL[2:0] determine the number of consecutive lines for which the out of lock condition must be true before the system switches into the unlocked state, and reports this via Status 0 [1:0].

Table 42. COL Function

COL[2:0]	Description (Count Value in Lines of Video)
000	1
001	2
010	5
011	10
100 (default)	100
101	500
110	1000
111	10000

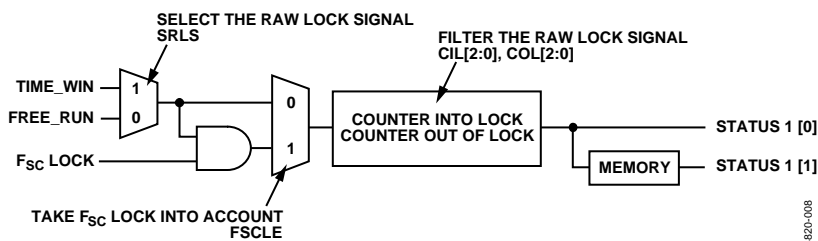

Figure 8. Lock Related Signal Path

COLOR CONTROLS

The following registers provide user control over the picture appearance, including control of the active data in the event of video being lost. They are independent of any other controls. For instance, brightness control is independent from picture clamping, although both controls affect the signal's dc level.

CON[7:0] Contrast Adjust, Address 0x08 [7:0]

This register allows the user to adjust the contrast of the picture.

Table 43. CON Function

CON[7:0]	Description (Adjust Contrast of the Picture)
0x80 (default)	Gain on luma channel = 1.
0x00	Gain on luma channel = 0.
0xFF	Gain on luma channel = 2.

SAT[7:0] Saturation Adjust, Address 0x09 [7:0]

The user can adjust the saturation of the color output using this register.

ADI encourages users not to use the SAT[7:0] register, which may be removed in future revisions of the ADV7181. Instead, the SD_SAT_Cb and SD_SAT_Cr registers should be used.

Table 44. SAT Function

SAT[7:0]	Description (Adjust Saturation of the Picture)
0x80 (default)	Chroma gain = 0 dB.
0x00	Chroma gain = -42 dB.
0xFF	Chroma gain = 6 dB.

SD_SAT_Cb[7:0] SD Saturation Cb Channel, Address 0xE3 [7:0]

This register allows the user to control the gain of the Cb channel only.

For this register to be active, SAT[7:0] must be programmed with its default value of 0x80. If SAT[7:0] is programmed with a different value, SD_SAT_Cb[7:0] and SD_SAT_Cr[7:0] are inactive.

Table 45. SD_SAT_Cb Function

SD_SAT_Cb[7:0]	Description (Adjust Saturation of the Picture)
0x80 (default)	Gain on Cb channel = 0 dB.
0x00	Gain on Cb channel = -42 dB.
0xFF	Gain on Cb channel = +6 dB.

SD_SAT_Cr[7:0] SD Saturation Cr Channel, Address 0xE4 [7:0]

This register allows the user to control the gain of the Cr channel only.

For this register to be active, SAT[7:0] must be programmed with its default value of 0x80. If SAT[7:0] is programmed with a different value, SD_SAT_Cb[7:0] and SD_SAT_Cr[7:0] are inactive.

Table 46. SD_SAT_Cr Function

SD_SAT_Cr[7:0]	Description (Adjust Saturation of the Picture)
0x80 (default)	Gain on Cr channel = 0 dB.
0x00	Gain on Cr channel = -42 dB.
0xFF	Gain on Cr channel = +6 dB.

SD_OFF_Cb[7:0] SD Offset Cb Channel, Address 0xE1 [7:0]

This register allows the user to select an offset for the Cb channel only. There is a functional overlap with the Hue [7:0] register.

Table 47. SD_OFF_Cb Function

SD_OFF_Cb[7:0]	Description (Adjust Hue of the Picture by Selecting an Offset for Data on the Cb Channel)
0x80 (default)	0 offset applied to the Cb channel.
0x00	-312 mV offset applied to the Cb channel.
0xFF	+312 mV offset applied to the Cb channel.

SD_OFF_Cr [7:0] SD Offset Cr Channel, Address 0xE2 [7:0]

This register allows the user to select an offset for the Cr channel only. There is a functional overlap with the Hue [7:0] register.

Table 48. SD_OFF_Cr Function

SD_OFF_Cr[7:0]	Description (Adjust Hue of the Picture by Selecting an Offset for Data on Cr Channel)
0x80 (default)	0 offset applied to the Cb channel.
0x00	-312 mV offset applied to the Cr channel.
0xFF	+312 mV offset applied to the Cr channel.

BRI[7:0] Brightness Adjust, Address 0x0A [7:0]

This register controls the brightness of the video signal through the ADV7181.

Table 49. BRI Function

BRI[7:0]	Description (Adjust Brightness of the Picture)
0x00 (default)	Offset of the luma channel = 0IRE.
0x7F	Offset of the luma channel = 100IRE.
0x80	Offset of the luma channel = -100IRE.

HUE[7:0] Hue Adjust, Address 0x0B [7:0]

This register contains the value for the color hue adjustment.

HUE[7:0] has a range of $\pm 90^\circ$, with 0x00 equivalent to an adjustment of 0° . The resolution of HUE[7:0] is 1 bit = 0.7° .

The hue adjustment value is fed into the AM color demodulation block. Therefore, it only applies to video signals that contain chroma information in the form of an AM modulated carrier (CVBS or Y/C in PAL or NTSC). It does not affect SECAM and does not work on component video inputs (YPrPb).

Table 50. HUE Function

HUE[7:0]	Description (Adjust Hue of the Picture)
0x00 (default)	Phase of the chroma signal = 0° .
0x7F	Phase of the chroma signal = $+90^\circ$.
0x80	Phase of the chroma signal = -90° .

DEF_Y[5:0] Default Value Y, Address 0x0C [7:2]

When the ADV7181 loses lock on the incoming video signal or when there is no input signal, the DEF_Y[5:0] register allows the user to specify a default luma value to be output.

This value is used under the following conditions:

- If DEF_VAL_AUTO_EN bit is set to high and the ADV7181 lost lock to the input video signal. This is the intended mode of operation (automatic mode).
- The DEF_VAL_EN bit is set, regardless of the lock status of the video decoder. This is a forced mode that may be useful during configuration.

The DEF_Y[5:0] values define the 6 MSBs of the output video. The remaining LSBs are padded with 0s. For example, in 8-bit mode, the output is $Y[7:0] = \{\text{DEF_Y}[5:0], 0, 0\}$.

Table 51. DEF_Y Function

DEF_Y[5:0]	Description
0x0D (blue) (default)	Default value of Y.

DEF_C[7:0] Default Value C, Address 0x0D [7:0]

The DEF_C[7:0] register complements the DEF_Y[5:0] value. It defines the 4 MSBs of Cr and Cb values to be output if

- The DEF_VAL_AUTO_EN bit is set to high and the ADV7181 can't lock to the input video (automatic mode).
- DEF_VAL_EN bit is set to high (forced output).

The data that is finally output from the ADV7181 for the chroma side is $Cr[7:0] = \{\text{DEF_C}[7:4], 0, 0, 0, 0\}$, $Cb[7:0] = \{\text{DEF_C}[3:0], 0, 0, 0, 0\}$.

Table 52. DEF_C Function

DEF_C[7:0]	Description
0x7C (blue) (default)	Default values for Cr and Cb.

DEF_VAL_EN Default Value Enable, Address 0x0C [0]

This bit forces the use of the default values for Y, Cr, and Cb. Refer to the descriptions for DEF_Y and DEF_C for additional information. The decoder also outputs a stable 27 MHz clock, HS, and VS in this mode.

Table 53. DEF_VAL_EN Function

DEF_VAL_EN	Description
0 (default)	Don't force the use of default Y, Cr, and Cb values. Output colors dependent on DEF_VAL_AUTO_EN.
1	Always use default Y, Cr, and Cb values. Override picture data even if the video decoder is locked.

DEF_VAL_AUTO_EN Default Value Automatic Enable, Address 0x0C [1]

This bit enables the automatic usage of the default values for Y, Cr, and Cb when the ADV7181 cannot lock to the video signal.

Table 54. DEF_VAL_AUTO_EN Function

DEF_VAL_AUTO_EN	Description
0	Don't use default Y, Cr, and Cb values. If unlocked, output noise.
1 (default)	Use default Y, Cr, and Cb values when the decoder loses lock.

CLAMP OPERATION

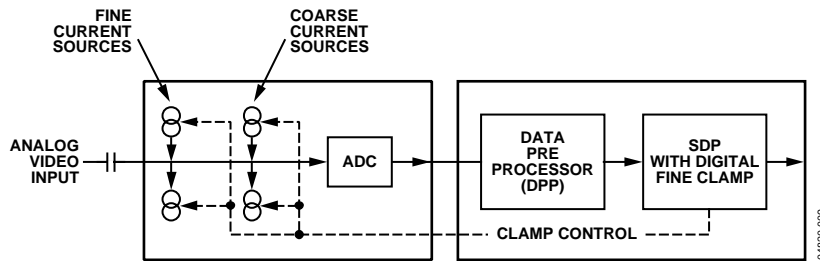

Figure 9. Clamping Overview

The input video is ac-coupled into the ADV7181 through a 0.1 μF capacitor. It is recommended that the range of the input video signal is 0.5 V to 1.6 V (typically 1 V p-p). If the signal exceeds this range, it cannot be processed correctly in the decoder. Since the input signal is ac-coupled into the decoder, its dc value needs to be restored. This process is referred to as clamping the video. This section explains the general process of clamping on the ADV7181 and shows the different ways in which a user can configure its behavior.

The ADV7181 uses a combination of current sources and a digital processing block for clamping, as shown in Figure 9. The analog processing channel shown is replicated three times inside the IC. While only one single channel (and only one ADC) would be needed for a CVBS signal, two independent channels are needed for YC (S-VHS) type signals, and three independent channels are needed to allow component signals (YPrPb) to be processed.

The clamping can be divided into two sections:

- Clamping before the ADC (analog domain): current sources.
- Clamping after the ADC (digital domain): digital processing block.

The ADCs can digitize an input signal only if it resides within the ADC's 1.6 V input voltage range. An input signal with a dc level that is too large or too small is clipped at the top or bottom of the ADC range.

The primary task of the analog clamping circuits is to ensure that the video signal stays within the valid ADC input window so the analog-to-digital conversion can take place. It is not necessary to clamp the input signal with a very high accuracy in the analog domain as long as the video signal fits the ADC range.

After digitization, the digital fine clamp block corrects for any remaining variations in dc level. Since the dc level of an input video signal refers directly to the brightness of the picture transmitted, it is important to perform a fine clamp with high accuracy; otherwise, brightness variations may occur. Furthermore, dynamic changes in the dc level almost certainly lead to visually objectionable artifacts, and must therefore be prohibited.

The clamping scheme has to complete two tasks: it must be able to acquire a newly connected video signal with a completely unknown dc level, and it must maintain the dc level during normal operation.

For a fast acquiring of an unknown video signal, the large current clamps may be activated. (It is assumed that the amplitude of the video signal at this point is of a nominal value.) Control of the coarse and fine current clamp parameters is performed automatically by the decoder.

Standard definition video signals may have excessive noise on them. In particular, CVBS signals transmitted by terrestrial broadcast and demodulated using a tuner usually show very large levels of noise (>100 mV). A voltage clamp would be unsuitable for this type of video signal. Instead, the ADV7181 employs a set of four current sources that can cause coarse (>0.5 mA) and fine (<0.1 mA) currents to flow into and away from the high impedance node that carries the video signal (see Figure 9).

The following sections describe the I²C signals that can be used to influence the behavior of the clamping.

Previous revisions of the ADV7181 had controls (FACL/FICL, fast and fine clamp length) to allow configuration of the length for which the coarse (fast) and fine current sources are switched on. These controls were removed on the ADV7181-FT and replaced by an adaptive scheme.

CCLEN Current Clamp Enable, Address 0x14 [4]

The current clamp enable bit allows the user to switch off the current sources in the analog front end altogether. This may be useful if the incoming analog video signal is clamped externally.

Table 55. CCLEN Function

CCLEN	Description
0	Current sources switched off.
1 (default)	Current sources enabled.

DCT[1:0] Digital Clamp Timing, Address 0x15 [6:5]

The Clamp Timing register determines the time constant of the digital fine clamp circuitry. It is important to realize that the digital fine clamp reacts very fast since it is supposed to immediately correct any residual dc level error for the active line. The time constant of the digital fine clamp must be much quicker than the one from the analog blocks.

By default, the time constant of the digital fine clamp is adjusted dynamically to suit the currently connected input signal.

Table 56. DCT Function

DCT[1:0]	Description
00	Slow (TC = 1 sec).
01	Medium (TC = 0.5 sec).
10 (default)	Fast (TC = 0.1 sec).
11	Determined by ADV7181 depending on video parameters.

DCFE Digital Clamp Freeze Enable, Address 0x15 [4]

This register bit allows the user to freeze the digital clamp loop at any time. It is intended for users who would like to do their own clamping. Users should disable the current sources for analog clamping via the appropriate register bits, wait until the digital clamp loop settles, and then freeze it via the DCFE bit.

Table 57. DCFE Function

DCFE	Description
0 (default)	Digital clamp operational.
1	Digital clamp loop frozen.

LUMA FILTER

Data from the digital fine clamp block is processed by three sets of filters. The data format at this point is CVBS for CVBS input or luma only for Y/C and YPrPb input formats.

- Luma antialias filter (YAA). The ADV7181 receives video at a rate of 27 MHz. (In the case of 4× oversampled video, the ADCs sample at 54 MHz, and the first decimation is performed inside the DPP filters. Therefore, the data rate into the ADV7181 is always 27 MHz.) The ITU-R BT.601 recommends a sampling frequency of 13.5 MHz. The luma antialias filter decimates the oversampled video using a high quality, linear phase, low-pass filter that preserves the luma signal while at the same time attenuating out-of-band components. The luma antialias filter (YAA) has a fixed response.
- Luma shaping filters (YSH). The shaping filter block is a programmable low-pass filter with a wide variety of responses. It can be used to selectively reduce the luma

video signal bandwidth (needed prior to scaling, for example). For some video sources that contain high frequency noise, reducing the bandwidth of the luma signal improves visual picture quality. A follow-on video compression stage may work more efficiently if the video is low-pass filtered.

The ADV7181 allows selection of two responses for the shaping filter: one that is used for good quality CVBS, component, and S-VHS type sources, and a second for nonstandard CVBS signals.

The YSH filter responses also include a set of notches for PAL and NTSC. However, it is recommended to use the comb filters for YC separation.

- Digital resampling filter. This block is used to allow dynamic resampling of the video signal to alter parameters such as the time base of a line of video. Fundamentally, the resampler is a set of low-pass filters. The actual response is chosen by the system with no requirement for user intervention.

Figure 11 through Figure 14 show the overall response of all filters together. Unless otherwise noted, the filters are set into a typical wideband mode.

Y Shaping Filter

For input signals in CVBS format, the luma shaping filters play an essential role in removing the chroma component from a composite signal. YC separation must aim for best possible crosstalk reduction while still retaining as much bandwidth (especially on the luma component) as possible. High quality YC separation can be achieved by using the internal comb filters of the ADV7181. Comb filtering, however, relies on the frequency relationship of the luma component (multiples of the video line rate) and the color subcarrier (Fsc). For good quality CVBS signals, this relationship is known; the comb filter algorithms can be used to separate out luma and chroma with high accuracy.

In the case of nonstandard video signals, the frequency relationship may be disturbed and the comb filters may not be able to remove all crosstalk artifacts in an optimum fashion without the assistance of the shaping filter block.

An automatic mode is provided. Here, the ADV7181 evaluates the quality of the incoming video signal and selects the filter responses in accordance with the signal quality and video standard. YFSM, WYSFMOVR, and WYSFM allow the user to manually override the automatic decisions in part or in full.

The luma shaping filter has three control registers:

- YFSM[4:0] allows the user to manually select a shaping filter mode (applied to all video signals) or to enable an automatic selection (depending on video quality and video standard).
- WYSFMOVR allows the user to manually override the WYSFM decision.
- WYSFM[4:0] allows the user to select a different shaping filter mode for good quality CVBS, component (YPrPb), and S-VHS (YC) input signals.

In automatic mode, the system preserves the maximum possible bandwidth for good CVBS sources (since they can successfully be combed) as well as for luma components of YPrPb and YC sources, since they need not be combed. For poor quality signals, the system selects from a set of proprietary shaping filter responses that complements comb filter operation in order to reduce visual artifacts.

The decisions of the control logic are shown in Figure 10.

YFSM[4:0] Y Shaping Filter Mode, Address 0x17 [4:0]

The Y shaping filter mode bits allow the user to select from a wide range of low-pass and notch filters. When switched in automatic mode, the filter is selected based on other register

selections, for example, detected video standard, as well as properties extracted from the incoming video itself, for example, quality, time base stability. The automatic selection always picks the widest possible bandwidth for the video input encountered.

- If the YFSM settings specify a filter (that is, YFSM is set to values other than 00000 or 00001), the chosen filter is applied to all video, regardless of its quality.
- In automatic selection mode, the notch filters are only used for bad quality video signals. For all other video signals, wideband filters are used.

WYSFMOVR Wideband Y Shaping Filter Override, Address 0x18 [7]

Setting the WYSFMOVR bit enables the use of the WYSFM[4:0] settings for good quality video signals. For more information, refer to the general discussion of the luma shaping filters in the Y Shaping Filter section and the flowchart shown in Figure 10.

Table 58. WYSFMOVR Function

WYSFMOVR	Description
0	Automatic selection of shaping filter for good quality video signals.
1 (default)	Enable manual override via WYSFM[4:0].

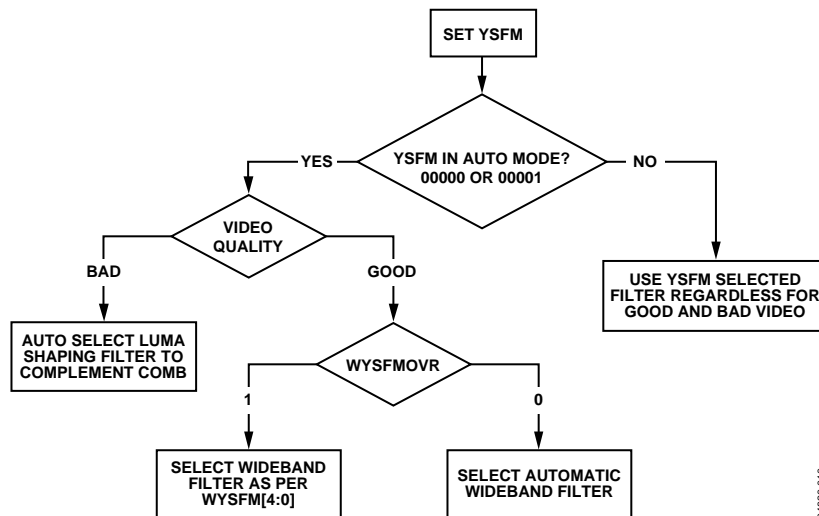

Figure 10. YFSM and WYSFM Control Flowchart

Table 59. YSFM Function

YSFM[4:0]	Description
0'0000	Automatic selection including a wide notch response (PAL/NTSC/SECAM)
0'0001 (default)	Automatic selection including a narrow notch response (PAL/NTSC/SECAM)
0'0010	SVHS 1
0'0011	SVHS 2
0'0100	SVHS 3
0'0101	SVHS 4
0'0110	SVHS 5
0'0111	SVHS 6
0'1000	SVHS 7
0'1001	SVHS 8
0'1010	SVHS 9
0'1011	SVHS 10
0'1100	SVHS 11
0'1101	SVHS 12
0'1110	SVHS 13
0'1111	SVHS 14
1'0000	SVHS 15
1'0001	SVHS 16
1'0010	SVHS 17
1'0011	SVHS 18 (CCIR 601)
1'0100	PAL NN 1
1'0101	PAL NN 2
1'0110	PAL NN 3
1'0111	PAL WN 1
1'1000	PAL WN 2
1'1001	NTSC NN 1
1'1010	NTSC NN 2
1'1011	NTSC NN 3
1'1100	NTSC WN 1
1'1101	NTSC WN 2
1'1110	NTSC WN 3
1'1111	Reserved.

WYSFM[4:0] Wide Band Y Shaping Filter Mode, Address 0x18 [4:0]

The WYSFM[4:0] bits allow the user to manually select a shaping filter for good quality video signals, for example, CVBS with stable time base, luma component of YPrPb, luma component of YC. The WYSFM bits are only active if the WYSFMOVR bit is set to 1. See the general discussion of the shaping filter settings in the Y Shaping Filter section.

Table 60. WYSFM Function

WYSFM[4:0]	Description
0'0000	Do not use
0'0001	Do not use
0'0010	SVHS 1
0'0011	SVHS 2
0'0100	SVHS 3
0'0101	SVHS 4
0'0110	SVHS 5
0'0111	SVHS 6
0'1000	SVHS 7
0'1001	SVHS 8
0'1010	SVHS 9
0'1011	SVHS 10
0'1100	SVHS 11
0'1101	SVHS 12
0'1110	SVHS 13
0'1111	SVHS 14
1'0000	SVHS 15
1'0001	SVHS 16
1'0010	SVHS 17
1'0011 (default)	SVHS 18 (CCIR 601)
1'0100–1'1111	Do not use

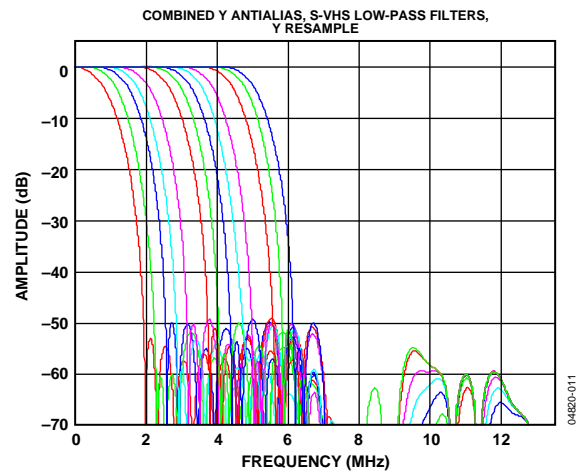

Figure 11. Y S-VHS Combined Responses

The filter plots in Figure 11 and Figure 22 show the S-VHS 1 (narrowest) to S-VHS 18 (widest) shaping filter settings. Figure 13 shows the PAL notch filter responses. The NTSC-compatible notches are shown in Figure 14.

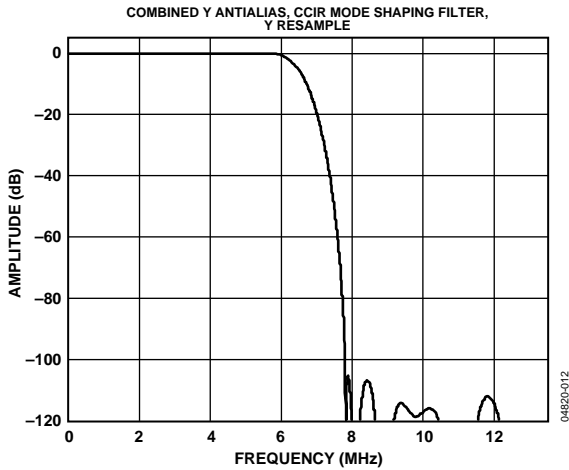

Figure 12. Y S-VHS 18 Extra Wideband Filter (CCIR 601-Compliant)

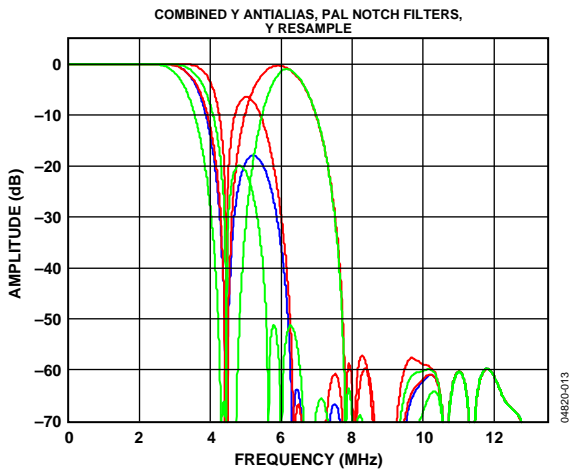

Figure 13. Pal Notch Filter Response

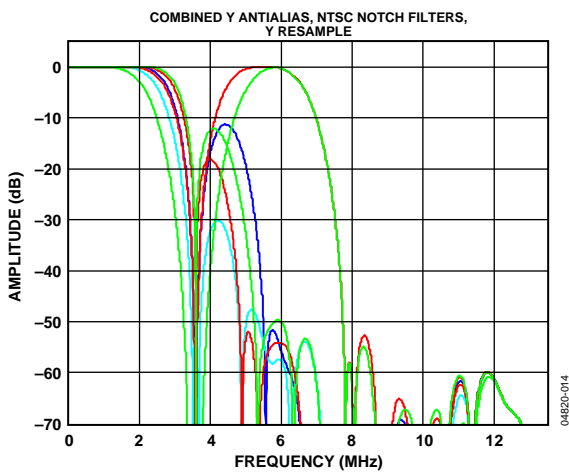

Figure 14. NTSC Notch Filter Response

CHROMA FILTER

Data from the digital fine clamp block is processed by three sets of filters. The data format at this point is CVBS for CVBS inputs, chroma only for Y/C, or U/V interleaved for YPrPb input formats.

- Chroma Anti-alias Filter (CAA). The ADV7181 over-samples the CVBS by a factor of 2 and the Chroma/PrPb by a factor of 4. A decimating filter (CAA) is used to preserve the active video band and remove any out-of-band components. The CAA filter has a fixed response.
- Chroma Shaping Filters (CSH). The shaping filter block (CSH) can be programmed to perform a variety of low-pass responses. It can be used to selectively reduce the bandwidth of the chroma signal for scaling or compression.
- Digital Resampling Filter. This block is used to allow dynamic resampling of the video signal to alter parameters such as the time base of a line of video. Fundamentally, the resampler is a set of low-pass filters. The actual response is chosen by the system with no requirement for user intervention.

The plots in Figure 15 show the overall response of all filters together.

CSFM[2:0] C Shaping Filter Mode, Address 0x17 [7]

The C shaping filter mode bits allow the user to select from a range of low-pass filters for the chrominance signal. When switched into automatic mode, the widest filter is selected based on the video standard/format and on user choice (see settings 000 and 001 in Table 61).

Table 61. CSFM Function

CSFM[2:0]	Description
000 (default)	Autoselect 1.5 MHz bandwidth
001	Autoselect 2.17 MHz bandwidth
010	SH1
011	SH2
100	SH3
101	SH4
110	SH5
111	Wideband mode

Figure 15 shows the responses of SH1 (narrowest) to SH5 (widest) in addition to the wideband mode (in red).

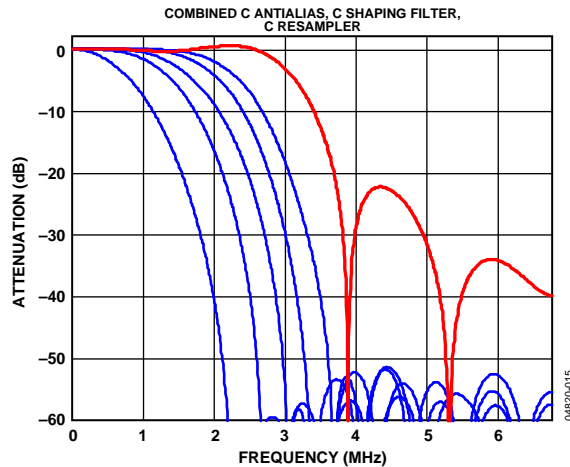

Figure 15. Chroma Shaping Filter Responses

GAIN OPERATION

The gain control within the ADV7181 is done on a purely digital basis. The input ADCs support a 9-bit range, mapped into a 1.6 V analog voltage range. Gain correction takes place after the digitization in the form of a digital multiplier.

There are several advantages of this architecture over the commonly used PGA (programmable gain amplifier) before the ADCs; among them is the fact that the gain is now completely independent of supply, temperature, and process variations.

As shown in Figure 16, the ADV7181 can decode a video signal as long as it fits into the ADC window. There are two components

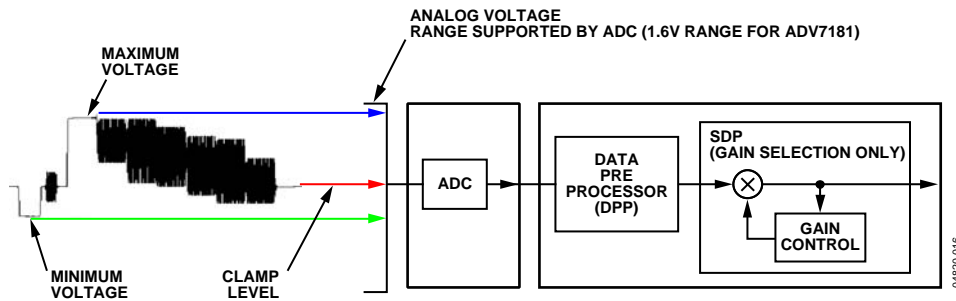

Figure 16. Gain Control Overview

Table 62. AGC Modes

Input Video Type	Luma Gain	Chroma Gain
Any	Manual gain luma.	Manual gain chroma.
CVBS	Dependent on horizontal sync depth.	Dependent on color burst amplitude. Taken from luma path.
	Peak White	Dependent on color burst amplitude. Taken from luma path.
Y/C	Dependent on horizontal sync depth.	Dependent on color burst amplitude. Taken from luma path.
	Peak White.	Dependent on color burst amplitude. Taken from luma path.
YPrPb	Dependent on horizontal sync depth.	Taken from luma path.

to this: the amplitude of the input signal and the dc level it resides on. The dc level is set by the clamping circuitry (see the Clamp Operation section).

If the amplitude of the analog video signal is too high, clipping may occur, resulting in visual artifacts. The analog input range of the ADC, together with the clamp level, determines the maximum supported amplitude of the video signal.

The minimum supported amplitude of the input video is determined by the ADV7181's ability to retrieve horizontal and vertical timing and to lock to the color burst (if present).

There are two gain control units, one each for luma and chroma data. Both can operate independently of each other. The chroma unit, however, can also take its gain value from the luma path.

Several AGC modes are possible; Table 62 summarizes them.

It is possible to freeze the automatic gain control loops. This causes the loops to stop updating. The AGC determined gain at the time of the freeze stays active until the loop is either unfrozen or the gain mode of operation is changed.

The currently active gain from any of the modes can be read back. Refer to the description of the dual-function manual gain registers, LG[11:0] Luma Gain and CG[11:0] Chroma Gain, in the Luma Gain and Chroma Gain sections.

Luma Gain

LAGC[2:0] Luma Automatic Gain Control, Address 0x2C [7:0]

The luma automatic gain control mode bits select the mode of operation for the gain control in the luma path.

There are ADI internal parameters to customize the peak white gain control. Contact ADI for more information.

Table 63. LAGC Function

LAGC[2:0]	Description
000	Manual fixed gain (use LMG[11:0]).
001	AGC (blank level to sync tip). No override through white peak.
010 (default)	AGC (blank level to sync tip). Automatic override through white peak.
011	Reserved.
100	Reserved.
101	Reserved.
110	Reserved.
111	Freeze gain.

LAGT[1:0] Luma Automatic Gain Timing, Address 0x2F [7:6]

The luma automatic gain timing register allows the user to influence the tracking speed of the luminance automatic gain control. This register has an effect only if the LAGC[2:0] register is set to 001, 010, 011, or 100 (automatic gain control modes).

If peak white AGC is enabled and active (see the STATUS_1[7:0] Address 0x10 [7:0] section), the actual gain update speed is dictated by the peak white AGC loop and, as a result, the LAGT settings have no effect. As soon as the part leaves peak white AGC, LAGT becomes relevant again.

The update speed for the peak white algorithm can be customized by the use of internal parameters. Contact ADI for more information.

Table 64. LAGT Function

LAGT[1:0]	Description
00	Slow (TC = 2 s)
01	Medium (TC = 1 s)
10	Fast (TC = 0.2 s)
11 (default)	Adaptive

LG[11:0] Luma Gain, Address 0x2F [3:0]; Address 0x30 [7:0]; LMG[11:0] Luma Manual Gain, Address 0x2F [3:0]; Address 0x30 [7:0]

Luma gain [11:0] is a dual-function register:

- If written to, a desired manual luma gain can be programmed. This gain becomes active if the LAGC[2:0] mode is switched to manual fixed gain.
- Equation 1 shows how to calculate a desired gain.
- If read back, this register returns the current gain value. Depending on the setting in the LAGC [2:0] bits, this is one of the following values:
 - Luma manual gain value (LAGC [2:0] set to luma manual gain mode).
 - Luma automatic gain value (LAGC [2:0] set to any of the automatic modes).

Table 65. LG/LMG Function

LG[11:0]/LMG[11:0]	Read/Write	Description
LMG[11:0] = X	Write	Manual gain for luma path
LG[11:0]	Read	Actually used gain

$$Luma_Gain = \frac{(0 < LG \leq 4095)}{2048} = 0...2 \quad (1)$$

Example

Program the ADV7181 into manual fixed gain mode with a desired gain of 0.89

1. Use Equation 1 to convert the gain:
 $0.89 \times 2048 = 1822.72$
2. Truncate to integer value:
 $1822.72 = 1822$
3. Convert to hexadecimal:
 $1822d = 0x71E$
4. Split into two registers and program:
Luma Gain Control 1 [3:0] = 0x7
Luma Gain Control 2 [7:0] = 0x1E
5. Enable Manual Fixed Gain Mode:
Set LAGC[2:0] to 000

BETACAM Enable Betacam Levels, Address 0x01 [5]

If YPrPb data is routed through the ADV7181, the automatic gain control modes can target different video input levels, as outlined in Table 70. The BETACAM bit is valid only if the input mode is YPrPb (component). The BETACAM bit sets the target value for AGC operation.

A review of the following sections is useful:

- SETADC_sw_man_en, Manual Input Muxing Enable, Address C4 [7] to find how component video (YPrPb) can be routed through the ADV7181.
- Video Standard Selection to select the various standards, for example, with and without pedestal.

The automatic gain control (AGC) algorithms adjust the levels based on the setting of the BETACAM bit (see Table 66.).

Table 66. BETACAM Function

BETACAM	Description
0 (default)	Assuming YPrPb is selected as input format. Selecting PAL with pedestal selects MII. Selecting PAL without pedestal selects SMPTE. Selecting NTSC with pedestal selects MII. Selecting NTSC without pedestal selects SMPTE.
1	Assuming YPrPb is selected as input format. Selecting PAL with pedestal selects BETACAM. Selecting PAL without pedestal selects BETACAM variant. Selecting NTSC with pedestal selects BETACAM. Selecting NTSC without pedestal selects BETACAM variant.

PW_UPD Peak White Update, Address 0x2B [0]

The peak white and average video algorithms determine the gain based on measurements taken from the active video. The PW_UPD bit determines the rate of gain change. LAGC[2:0] must be set to the appropriate mode to enable the peak white or average video mode in the first place. For more information, refer to the LAGC[2:0] Luma Automatic Gain Control, Address 0x2C [7:0] section.

Table 70. Betacam Levels

Name	Betacam (mV)	Betacam Variant (mV)	SMPTE (mV)	III (mV)
Y Range	0 to 714 (incl. 7.5% pedestal)	0 to 714	0 to 700	0 to 700 (incl. 7.5% pedestal)
Pb and Pr Range	-467 to +467	-505 to +505	-350 to +350	-324 to +324
Sync Depth	286	286	300	300

Table 67. PW_UPD Function

PW_UPD	Description
0	Update gain once per video line.
1 (default)	Update gain once per field.

Chroma Gain**CAGC[1:0] Chroma Automatic Gain Control, Address 0x2C [1:0]**

The two bits of Color Automatic Gain Control mode select the basic mode of operation for automatic gain control in the chroma path.

Table 68. CAGC Function

CAGC[1:0]	Description
00	Manual fixed gain (use CMG[11:0]).
01	Use luma gain for chroma.
10 (default)	Automatic gain (based on color burst).
11	Freeze chroma gain.

CAGT[1:0] Chroma Automatic Gain Timing, Address 0x2D [7:6]

The Chroma Automatic Gain Timing register allows the user to influence the tracking speed of the chroma automatic gain control. This register has an effect only if the CAGC[1:0] register is set to 10 (automatic gain).

Table 69. CAGT Function

CAGT[1:0]	Description
00	Slow (TC = 2 s)
01	Medium (TC = 1 s)
10	Fast (TC = 0.2 s)
11 (default)	Adaptive

**CG[11:0] Chroma Gain, Address 0x2D [3:0];
Address 0x2E [7:0] CMG[11:0] Chroma Manual Gain,
Address 0x2D [3:0]; Address 0x2E [7:0]**

Chroma gain [11:0] is a dual-function register:

- If written to, a desired manual chroma gain can be programmed. This gain becomes active if the CAGC[1:0] mode is switched to manual fixed gain.
- Refer to Equation 2 for calculating a desired gain.
- If read back, this register returns the current gain value. Depending on the setting in the CAGC[1:0] bits, this is one of the following values:
 - Chroma manual gain value (CAGC[1:0] set to chroma manual gain mode).
 - Chroma automatic gain value (CAGC[1:0] set to any of the automatic modes).

Table 71. CG/CMG Function

CG[11:0]/CMG[11:0]	Read/Write	Description
CMG[11:0]	Write	Manual gain for chroma path.
CG[11:0]	Read	Currently active gain.

$$Chroma_Gain = \frac{(0 < CG \leq 4095)}{1024} = 0...4 \quad (2)$$

Example

Freezing the automatic gain loop and reading back the CG[11:0] register results in a value of 0x47A.

1. Convert the read back value to decimal:
0x47A = 1146d
2. Apply Equation 2 to convert the readback value:
1146/1024 = 1.12

CKE Color Kill Enable, Address 0x2B [6]

The Color Kill Enable bit allows the optional color kill function to be switched on or off.

For QAM-based video standards (PAL and NTSC) as well as FM-based systems (SECAM), the threshold for the color kill decision is selectable via the CKILLTHR[2:0] bits.

If color kill is enabled, and if the color carrier of the incoming video signal is less than the threshold for 128 consecutive video lines, color processing is switched off (black and white output). To switch the color processing back on, another 128 consecutive lines with a color burst greater than the threshold are required.

The color kill option only works for input signals with a modulated chroma part. For component input (YPrPb), there is no color kill.

Table 72. CKE Function

CKE	Description
0	Color kill disabled.
1 (default)	Color kill enabled.

CKILLTHR[2:0] Color Kill Threshold, Address 0x3D [6:4]

The CKILLTHR[2:0] bits allow the user to select a threshold for the color kill function. The threshold only applies to QAM-based (NTSC and PAL) or FM modulated (SECAM) video standards.

To enable the color kill function, the CKE bit must be set. For settings 000, 001, 010, and 011, chroma demodulation inside the ADV7181 may not work satisfactorily for poor input video signals.

Table 73. CKILLTHR Function

CKILLTHR[2:0]	Description	
	SECAM	NTSC, PAL
000	No color kill	Kill at < 0.5%
001	Kill at < 5%	Kill at < 1.5%
010	Kill at < 7%	Kill at < 2.5%
011	Kill at < 8%	Kill at < 4.0%
100 (default)	Kill at < 9.5%	Kill at < 8.5%
101	Kill at < 15%	Kill at < 16.0%
110	Kill at < 32%	Kill at < 32.0%
111	Reserved for ADI internal use only. Do not select.	

CHROMA TRANSIENT IMPROVEMENT (CTI)

The signal bandwidth allocated for chroma is typically much smaller than that of luminance. In the past, this was a valid way to fit a color video signal into a given overall bandwidth because the human eye is less sensitive to chrominance than to luminance.

The uneven bandwidth, however, can lead to some visual artifact when it comes to sharp color transitions. At the border of two bars of color, both components (luma and chroma) change at the same time (see Figure 17). Due to the higher bandwidth, the signal transition of the luma component is usually a lot sharper than that of the chroma component. The color edge is not sharp but blurred, in the worst case, over several pixels.

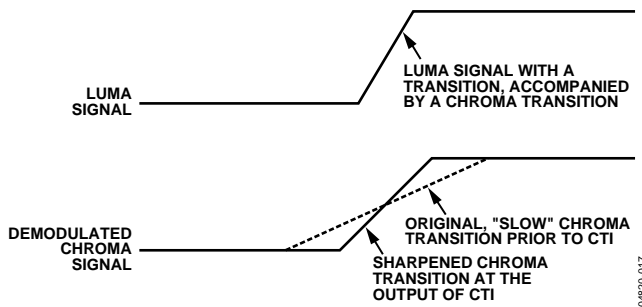

Figure 17. CTI Luma/Chroma Transition

The chroma transient improvement block examines the input video data. It detects transitions of chroma, and can be programmed to “steepen” the chroma edges in an attempt to artificially restore lost color bandwidth. The CTI block, however, only operates on edges above a certain threshold to ensure that noise is not emphasized. Care has been taken to ensure that edge ringing and undesirable saturation or hue distortion are avoided.

Chroma transient improvements are needed primarily for signals that experienced severe chroma bandwidth limitations. For those types of signals, it is strongly recommended to enable the CTI block via CTI_EN.

CTI_EN Chroma Transient Improvement Enable, Address 0x4D [0]

The CTI_EN bit enables the CTI function. If set to 0, the CTI block is inactive and the chroma transients are left untouched.

Table 74. CTI_EN Function

CTI_EN	Description
0 (default)	Disable CTI.
1	Enable CTI block.

CTI_AB_EN Chroma Transient Improvement Alpha Blend Enable, Address 0x4D [1]

The CTI_AB_EN bit enables an alpha-blend function within the CTI block. If set to 1, the alpha blender mixes the transient improved chroma with the original signal. The sharpness of the alpha blending can be configured via the CTI_AB[1:0] bits.

For the alpha blender to be active, the CTI block must be enabled via the CTI_EN bit.

Table 75. CTI_AB_EN Function

CTI_AB_EN	Description
0	Disable CTI alpha blender.
1 (default)	Enable CTI alpha-blend mixing function.

CTI_AB[1:0] Chroma Transient Improvement Alpha Blend, Address 0x4D [3:2]

The CTI_AB[1:0] controls the behavior of alpha-blend circuitry that mixes the sharpened chroma signal with the original one. It thereby controls the visual impact of CTI on the output data.

For CTI_AB[1:0] to become effective, the CTI block must be enabled via the CTI_EN bit, and the alpha blender must be switched on via CTI_AB_EN.

Sharp blending maximizes the effect of CTI on the picture, but can also increase the visual impact of small amplitude, high frequency chroma noise.

Table 76. CTI_AB Function

CTI_AB[1:0]	Description
00	Sharpest mixing between sharpened and original chroma signal.
01	Sharp mixing.
10	Smooth mixing.
11 (default)	Smoothest alpha blend function.

CTI_C_TH[7:0] CTI Chroma Threshold, Address 0x4E [7:0]

The CTI_C_TH[7:0] value is an unsigned, 8-bit number specifying how big the amplitude step in a chroma transition has to be in order to be steepened by the CTI block. Programming a small value into this register causes even smaller edges to be steepened by the CTI block. Making CTI_C_TH[7:0] a large value causes the block to improve large transitions only.

Table 77. CTI_C_TH Function

CTI_C_TH[7:0]	Description
0x08 (default)	Threshold for chroma edges prior to CTI.

DIGITAL NOISE REDUCTION (DNR)

Digital noise reduction is based on the assumption that high frequency signals with low amplitude are probably noise, and that their removal therefore improves picture quality.

DNR_EN Digital Noise Reduction Enable, Address 0x4D [5]

The DNR_EN bit enables the DNR block or bypasses it.

Table 78. DNR_EN Function

DNR_EN	Description
0	Bypass DNR (disable).
1 (default)	Enable digital noise reduction on the luma data.

DNR_TH[7:0] DNR Noise Threshold, Address 0x50 [7:0]

The DNR_TH[7:0] value is an unsigned 8-bit number used to determine the maximum edge that is interpreted as noise and therefore blanked from the luma data. Programming a large value into DNR_TH[7:0] causes the DNR block to interpret even large transients as noise and remove them. The effect on the video data is therefore more visible.

Programming a small value causes only small transients to be seen as noise and to be removed.

The recommended DNR_TH[7:0] setting for A/V inputs is 0x04, and the recommended DNR_TH[7:0] setting for tuner inputs is 0x0A.

Table 79. DNR_TH Function

DNR_TH[7:0]	Description
0x08 (default)	Threshold for maximum luma edges to be interpreted as noise.

COMB FILTERS

The comb filters of the ADV7181 have been greatly improved to automatically handle video of all types, standards, and levels of quality. Two user registers are available to customize comb filter operation.

Depending on whichever video standard has been detected (by autodetection) or selected (by manual programming), the NTSC or PAL configuration registers are used. In addition to the bits listed in this section, there are some further ADI internal controls; contact ADI for more information.

NTSC Comb Filter Settings

Used for NTSC-M/J CVBS inputs.

NSFSEL[1:0] Split Filter Selection NTSC, Address 0x19 [3:2]

The NSFSEL[1:0] control selects how much of the overall signal bandwidth is fed to the combs. A narrow split filter selection gives better performance on diagonal lines, but leaves more dot crawl in the final output image. The opposite is true for selecting a wide bandwidth split filter.

Table 80. NSFSEL Function

NSFSEL[1:0]	Description
00 (default)	Narrow
01	Medium
10	Medium
11	Wide

CTAPSN[1:0] Chroma Comb Taps NTSC, Address 0x38 [7:6]

Table 81. CTAPSN Function

CTAPSN[1:0]	Description
00	Do not use.
01	NTSC chroma comb adapts 3 lines (3 taps) to 2 lines (2 taps).
10 (default)	NTSC chroma comb adapts 5 lines (5 taps) to 3 lines (3 taps).
11	NTSC chroma comb adapts 5 lines (5 taps) to 4 lines (4 taps).

CCMN[2:0] Chroma Comb Mode NTSC, Address 0x38 [5:3]

Table 82. CCMN Function

CCMN[2:0]	Description	
0xx (default)	Adaptive comb mode.	Adaptive 3-line chroma comb for CTAPSN = 01. Adaptive 4-line chroma comb for CTAPSN = 10. Adaptive 5-line chroma comb for CTAPSN = 11.
100	Disable chroma comb.	
101	Fixed chroma comb (top lines of line memory).	Fixed 2-line chroma comb for CTAPSN = 01. Fixed 3-line chroma comb for CTAPSN = 10. Fixed 4-line chroma comb for CTAPSN = 11.
110	Fixed chroma comb (all lines of line memory).	Fixed 3-line chroma comb for CTAPSN = 01. Fixed 4-line chroma comb for CTAPSN = 10. Fixed 5-line chroma comb for CTAPSN = 11.
111	Fixed chroma comb (bottom lines of line memory).	Fixed 2-line chroma comb for CTAPSN = 01. Fixed 3-line chroma comb for CTAPSN = 10. Fixed 4-line chroma comb for CTAPSN = 11.

YCMN[2:0] Luma Comb Mode NTSC, Address 0x38 [2:0]

Table 83. YCMN Function

YCMN[2:0]	Description	
0xx (default)	Adaptive comb mode.	Adaptive 3-line (3 taps) luma comb.
100	Disable luma comb.	Use low-pass/notch filter; see the Y Shaping Filter section.
101	Fixed luma comb (top lines of line memory).	Fixed 2-line (2 taps) luma comb.
110	Fixed luma comb (all lines of line memory).	Fixed 3-line (3 taps) luma comb.
111	Fixed luma comb (bottom lines of line memory).	Fixed 2-line (2 taps) luma comb.

ADV7181

PAL Comb Filter Settings

Used for PAL-B/G/H/I/D, PAL-M, PAL-Combinational N, PAL-60, and NTSC443 CVBS inputs.

PSFSEL[1:0] Split Filter Selection PAL, Address 0x19 [1:0]

The NSFSEL[1:0] control selects how much of the overall signal bandwidth is fed to the combs. A wide split filter selection eliminates dot crawl, but shows imperfections on diagonal lines. The opposite is true for selecting a narrow bandwidth split filter.

Table 84. PSFSEL Function

PSFSEL[1:0]	Description
00	Narrow
01 (default)	Medium
10	Wide
11	Widest

CTAPSP[1:0] Chroma Comb Taps PAL, Address 0x39 [7:6]

Table 85. CTAPSP Function

CTAPSP[1:0]	Description
00	Do not use.
01	PAL chroma comb adapts 5 lines (3 taps) to 3 lines (2 taps); cancels cross luma only.
10	PAL chroma comb adapts 5 lines (5 taps) to 3 lines (3 taps); cancels cross luma and hue error less well.
11 (default)	PAL chroma comb adapts 5 lines (5 taps) to 4 lines (4 taps); cancels cross luma and hue error well.

CCMP[2:0] Chroma Comb Mode PAL, Address 0x39 [5:3]

Table 86. CCMP Function

CCMP[2:0]	Description	
0xx (default)	Adaptive comb mode.	Adaptive 3-line chroma comb for CTAPSP = 01. Adaptive 4-line chroma comb for CTAPSP = 10. Adaptive 5-line chroma comb for CTAPSP = 11.
100	Disable chroma comb.	
101	Fixed chroma comb (top lines of line memory).	Fixed 2-line chroma comb for CTAPSP = 01. Fixed 3-line chroma comb for CTAPSP = 10. Fixed 4-line chroma comb for CTAPSP = 11.
110	Fixed chroma comb (all lines of line memory).	Fixed 3-line chroma comb for CTAPSP = 01. Fixed 4-line chroma comb for CTAPSP = 10. Fixed 5-line chroma comb for CTAPSP = 11.
111	Fixed chroma comb (bottom lines of line memory).	Fixed 2-line chroma comb for CTAPSP = 01. Fixed 3-line chroma comb for CTAPSP = 10. Fixed 4-line chroma comb for CTAPSP = 11.

YCMP[2:0] Luma Comb Mode PAL, Address 0x39 [2:0]

Table 87. YCMP Function

YCMP[2:0]	Description	
0xx (default)	Adaptive comb mode.	Adaptive 5 lines (3 taps) luma comb.
100	Disable luma comb.	Use low-pass/notch filter; see the Y Shaping Filter section.
101	Fixed luma comb (top lines of line memory).	Fixed 3 lines (2 taps) luma comb.
110	Fixed luma comb (all lines of line memory).	Fixed 5 lines (3 taps) luma comb.
111	Fixed luma comb (bottom lines of line memory).	Fixed 3 lines (2 taps) luma comb.

AV CODE INSERTION AND CONTROLS

This section describes the I²C-based controls that affect

- Insertion of AV codes into the data stream
- Data blanking during the vertical blank interval (VBI)
- The range of data values permitted in the output data stream
- The relative delay of luma vs. chroma signals

Some of the decoded VBI data is being inserted during the horizontal blanking interval. See the Gemstar Data Recovery section for more information.

BT656-4 ITU Standard BT-R.656-4 Enable, Address 0x04 [7]

The ITU has changed the position for toggling of the V bit within the SAV EAV codes for NTSC between revisions 3 and 4. The BT656-4 standard bit allows the user to select an output mode that is compliant with either the previous or the new standard. For further information, review the standard at <http://www.itu.int>.

The standard change affects NTSC only and has no bearing on PAL.

Table 88. BT656-4 Function

BT656-4	Description
0 (default)	BT656-3 Spec: V bit goes low at EAV of Lines 10 and 273.
1	BT656-4 Spec: V bit goes low at EAV of Lines 20 and 283.

SD_DUP_AV Duplicate AV Codes, Address 0x03 [0]

Depending on the output interface width, it may be necessary to duplicate the AV codes from the luma path into the chroma path.

In an 8-bit-wide output interface (Cb/Y/Cr/Y interleaved data), the AV codes are defined as FF/00/00/AV, with AV being the transmitted word that contains information about H/V/E.

In this output interface mode, the following assignment takes place: Cb = FF, Y = 00, Cr = 00, and Y = AV.

In a 16-bit output interface where Y and Cr/Cb are delivered via separate data buses, the AV code is over the whole 16 bits. The SD_DUP_AV bit allows the user to double up the AV codes, so the full sequence can be found on the Y bus as well as (= duplicated) the Cr/Cb bus. See Figure 18.

Table 89. SD_DUP_AV Function

SD_DUP_AV	Description
0	AV codes in single fashion (to suit 8-bit interleaved data output).
1	AV codes duplicated (for 16-bit interfaces).

VBI_EN Vertical Blanking Interval Data Enable, Address 0x03 [7]

The VBI enable bit allows data such as intercast and closed caption data to be passed through the luma channel of the decoder with only a minimal amount of filtering. All data for Lines 1 to 21 is passed through and available at the output port. The ADV7181 does not blank the luma data, and automatically switches all filters along the luma data path into their widest bandwidth. For active video, the filter settings for YSH and YPK are restored.

Refer to the BL_C_VBI Blank Chroma during VBI section for information on the chroma path.

Table 90. VBI_En Function

VBI_EN	Description
0 (default)	All video lines are filtered/scaled.
1	Only active video region is filtered/scaled.

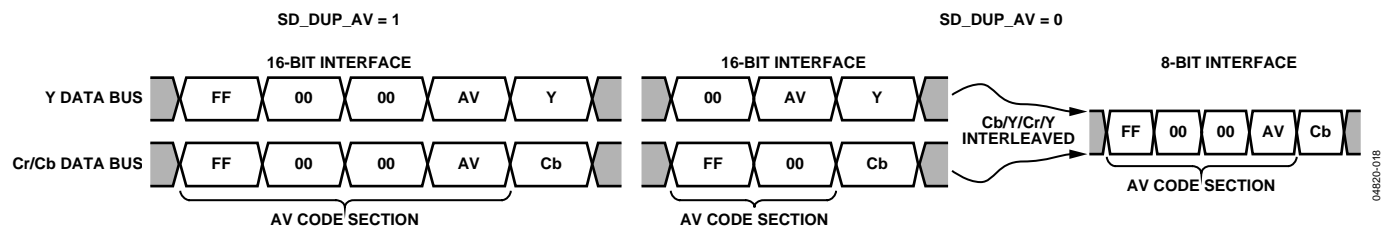

Figure 18. AV Code Duplication Control

BL_C_VBI Blank Chroma during VBI, Address 0x04 [2]

Setting BL_C_VBI high, the Cr and Cb values of all VBI lines get blanked. This is done so any data that comes during VBI is not decoded as color and output through Cr and Cb. As a result, it should be possible to send VBI lines into the decoder, then output them through an encoder again, undistorted. Without this blanking, any wrongly decoded color is encoded by the video encoder; therefore, the VBI lines are distorted.

Table 91. BL_C_VBI Function

BL_C_VBI	Description
0	Decode and output color during VBI.
1 (default)	Blank Cr and Cb values during VBI (no color, 0x80).

RANGE Range Selection, Address 0x04 [0]

AV codes (as per ITU-R BT-656, formerly known as CCIR-656) consist of a fixed header made up of 0xFF and 0x00 values. These two values are reserved and therefore are not to be used for active video. Additionally, the ITU also specifies that the nominal range for video should be restricted to values between 16 and 235 for luma and 16 to 240 for chroma.

The RANGE bit allows the user to limit the range of values output by the ADV7181 to the recommended value range. In any case, it is ensured that the reserved values of 255d (0xFF) and 00d (0x00) are not presented on the output pins unless they are part of an AV code header.

Table 92. RANGE Function

RANGE	Description	
0	$16 \leq Y \leq 235$	$16 \leq C/P \leq 240$
1 (default)	$1 \leq Y \leq 254$	$1 \leq C/P \leq 254$

AUTO_PDC_EN Automatic Programmed Delay Control, Address 0x27 [6]

Enabling the AUTO_PDC_EN function activates a function within the ADV7181 that automatically programs the LTA[1:0] and CTA[2:0] to have the chroma and luma data match delays for all modes of operation. If set, manual registers LTA[1:0] and CTA[2:0] are not used by the ADV7181. If the automatic mode is disabled (via setting the AUTO_PDC_EN bit to 0), the values programmed into LTA[1:0] and CTA[2:0] registers take effect.

Table 93. AUTO_PDC_EN Function

AUTO_PDC_EN	Description
0	Use LTA[1:0] and CTA[2:0] values for delaying luma and chroma samples. Refer to the LTA[1:0] Luma Timing Adjust, Address 0x27 [1:0] and CTA[2:0] Chroma Timing Adjust, Address 0x27 [5:3] sections.
1 (default)	The ADV7181 automatically determines the LTA and CTA values to have luma and chroma aligned at the output.

LTA[1:0] Luma Timing Adjust, Address 0x27 [1:0]

The Luma Timing Adjust register allows the user to specify a timing difference between chroma and luma samples.

There is a certain functionality overlap with the CTA[2:0] register.

For manual programming, use the following defaults:

- CVBS input LTA[1:0] = 00
- YC input LTA[1:0] = 01
- YPrPb input LTA[1:0] = 01

Table 94. LTA Function

LTA[1:0]	Description
00 (default)	No delay.
01	Luma 1 clk (37 ns) delayed.
10	Luma 2clk (74 ns) early.
11	Luma 1 clk (37 ns) early.

CTA[2:0] Chroma Timing Adjust, Address 0x27 [5:3]

The Chroma Timing Adjust register allows the user to specify a timing difference between chroma and luma samples. This can be used to compensate for external filter group delay differences in the luma vs. chroma path, and to allow a different number of pipeline delays while processing the video down-stream. Review this functionality together with the LTA[1:0] register.

The chroma can only be delayed/advanced in chroma pixel steps. One chroma pixel step is equal to two luma pixels. The programmable delay occurs after demodulation, where one can no longer delay by luma pixel steps.

For manual programming, use the following defaults:

- CVBS input CTA[2:0] = 011
- YC input CTA[2:0] = 101
- YPrPb input CTA[2:0] = 110

Table 95. CTA Function

CTA[2:0]	Description
000	Not used.
001	Chroma + 2 chroma pixel (early).
010	Chroma + 1 chroma pixel (early).
011 (default)	No delay.
100	Chroma – 1 chroma pixel (late).
101	Chroma – 2 chroma pixel (late).
110	Chroma – 3 chroma pixel (late).
111	Not used.

SYNCHRONIZATION OUTPUT SIGNALS

HS Configuration

The following controls allow the user to configure the behavior of the HS output pin only:

- Beginning of HS signal via HSB[10:0]
- End of HS signal via HSE[10:0]
- Polarity of HS using PHS

HSB[10:0] HS Begin, Address 0x34 [6:4], Address 0x35 [7:0]

The HS Begin and HS End registers allow the user to freely position the HS output (pin) within the video line. The values in HSB[10:0] and HSE[10:0] are measured in pixel units from the falling edge of HS. Using both values, the user can program both the position and length of the HS output signal.

The position of this edge is controlled by placing a binary number into HSB[10:0]. The number applied offsets the edge with respect to an internal counter that is reset to 0 immediately after EAV code FF,00,00,XY (see Figure 19). HSB is set to 00000000010b, which is 2 LLC1 clock cycles from count[0].

Table 96. HSB Function

HSB[10:0]	Description
0x002	The HS pulse starts after the HSB[10:0] pixel after falling edge of HS.

HSE[10:0] HS End, Address 0x34 [2:0], Address 0x36 [7:0]

The HS Begin and HS End registers allow the user to freely position the HS output (pin) within the video line. The values in HSB[10:0] and HSE[10:0] are measured in pixel units from the falling edge of HS. Using both values, the user can program both the position and length of the HS output signal.

Table 99. HS Timing Parameters (see Figure 19)

Standard	HS Begin Adjust (HSB[10:0]) ¹	HS End Adjust (HSE[10:0]) ¹	HS to Active Video (LLC1 Clock Cycles) (C in Figure 19) ¹	Active Video Samples/Line (D in Figure 19)	Total LLC1 Clock Cycles (E in Figure 19)
NTSC	00000000010b	00000000000b	272	720Y + 720C = 1440	1716
NTSC Square Pixel	00000000010b	00000000000b	276	640Y + 640C = 1280	1560
PAL	00000000010b	00000000000b	284	720Y + 720C = 1440	1728

¹Default.

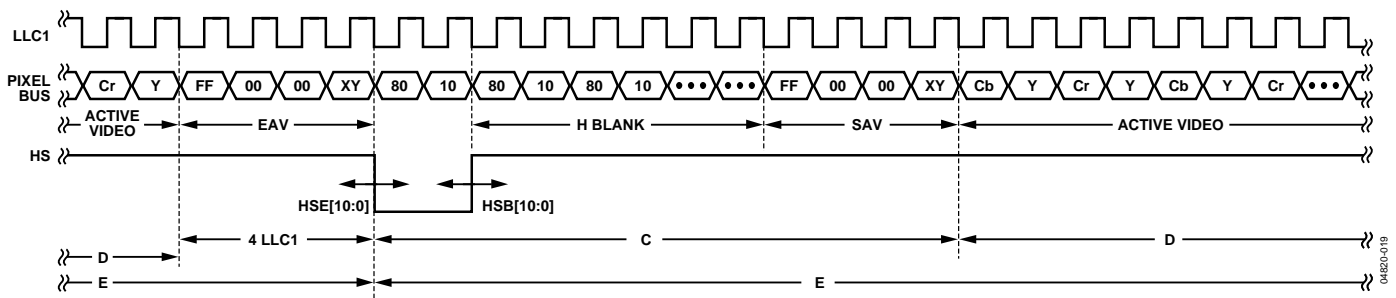

Figure 19. HS Timing

The position of this edge is controlled by placing a binary number into HSE[10:0]. The number applied offsets the edge with respect to an internal counter that is reset to 0 immediately after EAV code FF,00,00,XY (see Figure 19). HSE is set to 00000000000b, which is 0 LLC1 clock cycles from count[0].

Table 97. HSE Function

HSE[9:0]	Description
000 (default)	HS pulse ends after HSE[10:0] pixel after falling edge of HS.

Example

1. To shift the HS towards active video by 20 LLC1s, add 20 LLC1s to both HSB and HSE, that is, HSB[10:0] = [00000010110], HSE[10:0] = [00000010100]
2. To shift the HS away from active video by 20 LLC1s, add 1696 LLC1s to both HSB and HSE (for NTSC), that is, HSB[10:0] = [11010100010], HSE[10:0] = [11010100000]. (1696 is derived from the NTSC total number of pixels = 1716)

To move 20 LLC1s away from active video is equal to subtracting 20 from 1716 and adding the result in binary to both HSB[10:0] and HSE[10:0].

PHS Polarity HS, Address 0x37 [7]

The polarity of the HS pin can be inverted using the PHS bit.

Table 98. PHS Function

PHS	Description
0 (default)	HS active high.
1	HS active low.

VS and FIELD Configuration

The following controls allow the user to configure the behavior of the VS and FIELD output pins, as well as the generation of embedded AV codes:

- ADV encoder-compatible signals via NEWAVMODE
- PVS, PF
- HVSTIM
- VSBHO, VSBHE
- VSEHO, VSEHE
- For NTSC control:
 - NVBEGDELO, NVBEGDELE, NVBEGSIGN, NVBEG[4:0]
 - NVENDDELO, NVENDDELE, NVENDSIGN, NVEND[4:0]
 - NFTOGDELO, NFTOGDELE, NFTOGSIGN, NFTOG[4:0]
- For PAL control:
 - PVBEGDELO, PVBEGDELE, PVBEGSIGN, PVBEG[4:0]
 - PVENDDELO, PVENDDELE, PVENDSIGN, PVEND[4:0]
 - PFTOGDELO, PFTOGDELE, PFTOGSIGN, PFTOG[4:0]

NEWAVMODE New AV Mode, Address 0x31 [4]

Table 100. NEWAVMODE Function

NEWAVMODE	Description
0	EAV/SAV codes generated to suit ADI encoders. No adjustments possible.
1 (default)	Enable Manual Position of VSYNC, Field, and AV codes using 0x34 to 0x37 and 0xE5 to 0xEA. Default register settings are CCIR656 compliant; see Figure 20 for NTSC and Figure 25 for PAL. For recommended manual user settings, see Table 108 and Figure 21 for NTSC; see Table 121 and Figure 26 for PAL.

HVSTIM Horizontal VS Timing, Address 0x31 [3]

The HVSTIM bit allows the user to select where the VS signal is asserted within a line of video. Some interface circuitry may require VS to go low while HS is low.

Table 101. HVSTIM Function

HVSTIM	Description
0 (default)	Start of line relative to HSE.
1	Start of line relative to HSB.

VSBHO VS Begin Horizontal Position Odd, Address 0x32 [7]

The VSBHO and VSBHE bits select the position within a line at which the VS pin (not the bit in the AV code) becomes active. Some follow-on chips require the VS pin to change state only when HS is high/low.

Table 102. VSBHO Function

VSBHO	Description
0 (default)	VS pin goes high at the middle of a line of video (odd field).
1	VS pin changes state at the start of a line (odd field).

VSBHE VS Begin Horizontal Position Even, Address 0x32 [6]

The VSBHO and VSBHE bits select the position within a line at which the VS pin (not the bit in the AV code) becomes active. Some follow-on chips require the VS pin to change state only when HS is high/low.

Table 103. VSBHE Function

VSBHE	Description
0	VS pin goes high at the middle of a line of video (even field).
1 (default)	VS pin changes state at the start of a line (even field).

VSEHO VS End Horizontal Position Odd, Address 0x33 [7]

The VSEHO and VSEHE bits select the position within a line at which the VS pin (not the bit in the AV code) becomes active. Some follow-on chips require the VS pin to change state only when HS is high/low.

Table 104. VSEHO Function

VSEHO	Description
0	VS pin goes low (inactive) at the middle of a line of video (odd field).
1 (default)	VS pin changes state at the start of a line (odd field).

VSEHE VS End Horizontal Position Even, Address 0x33 [6]

The VSEHO and VSEHE bits select the position within a line at which the VS pin (not the bit in the AV code) becomes active. Some follow-on chips require the VS pin to change state only when HS is high/low.

Table 105. VSEHE Function

VSEHE	Description
0 (default)	VS pin goes low (inactive) at the middle of a line of video (even field).
1	VS pin changes state at the start of a line (even field).

PVS Polarity VS, Address 0x37 [5]

The polarity of the VS pin can be inverted using the PVS bit.

Table 106. PVS Function

PVS	Description
0 (default)	VS active high.
1	VS active low.

PF Polarity FIELD, Address 0x37 [3]

The polarity of the FIELD pin can be inverted using the PF bit.

Table 107. PF Function

PF	Description
0 (default)	FIELD active high.
1	FIELD active low.

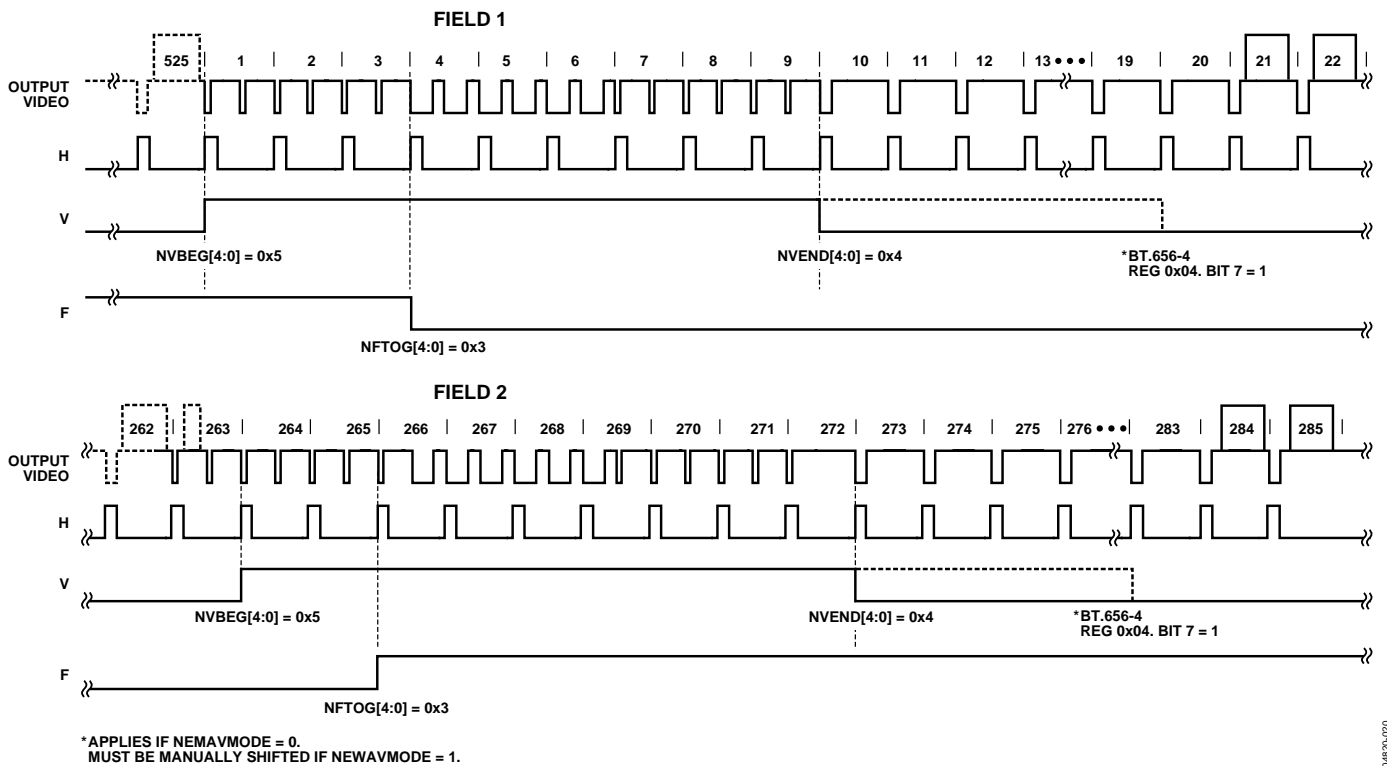

Figure 20. NTSC Default (BT.656). The polarity of H, V, and F is embedded in the data.

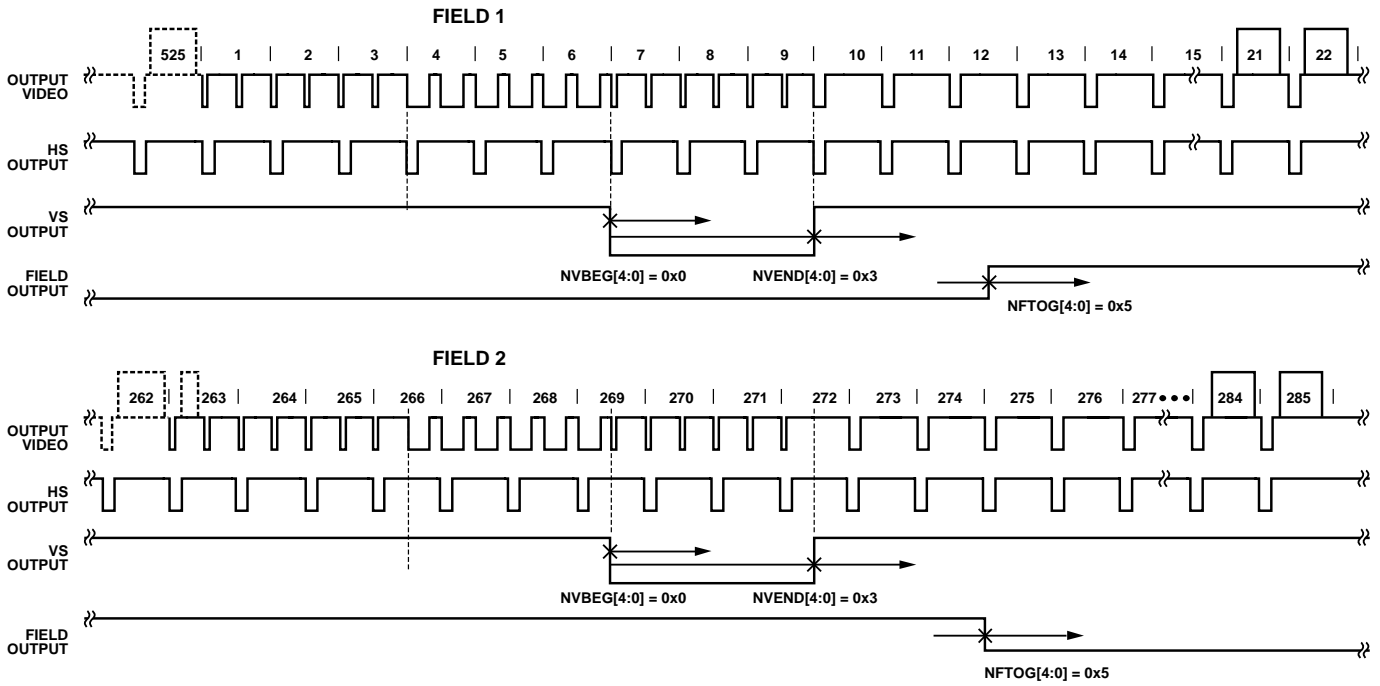

Figure 21. NTSC Typical VSync/Field Positions Using Register Writes in Table 108

Table 108. Recommended User Settings for NTSC (See Figure 21)

Register	Register Name	Write
0x31	VSync Field Control 1	0x12
0x32	VSync Field Control 2	0x81
0x33	VSync Field Control 3	0x84
0x37	Polarity	0x29
0xE5	NTSV_V_Bit_Beg	0x0
0xE6	NTSC_V_Bit_End	0x3
0xE7	NTSC_F_Bit_Tog	0x85

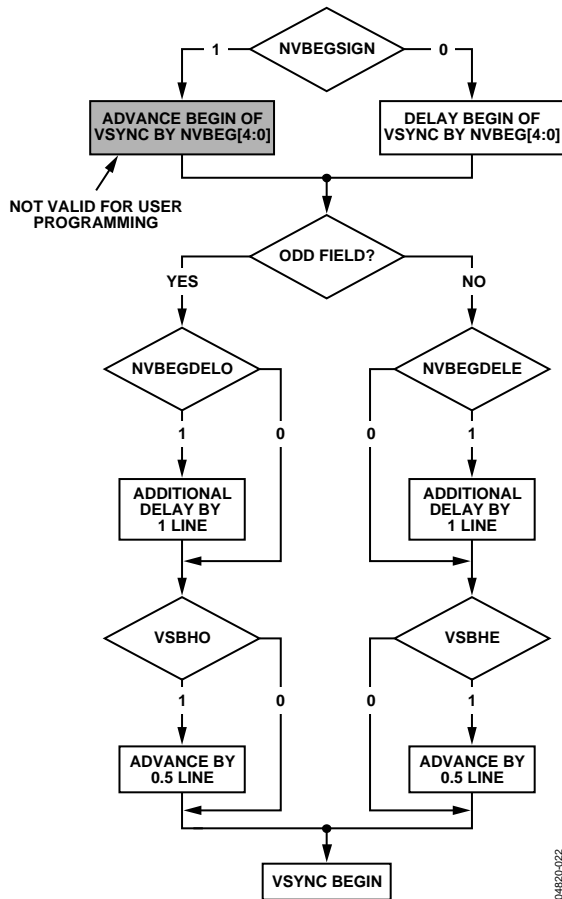

Figure 22. NTSC VSync Begin

NVBEGDELO NTSC VSync Begin Delay on Odd Field, Address 0xE5 [7]

Table 109. NVBEGDELO Function

NVBEGDELO	Description
0 (default)	No delay.
1	Delay VSync going high on an odd field by a line relative to NVBEG.

NVBEGDELE NTSC Vsync Begin Delay on Even Field, Address 0xE5 [6]

Table 110. NVBEGDELE Function

NVBEGDELE	Description
0 (default)	No delay.
1	Delay VSync going high on an even field by a line relative to NVBEG.

NVBEGSIGN NTSC VSync Begin Sign, Address 0xE5 [5]

Table 111. NVBEGSIGN Function

NVBEGSIGN	Description
0	Delay start of VSync. Set for user manual programming.
1 (default)	Advance start of VSync. Not recommended for user programming.

NVBEG[4:0] NTSC VSync Begin, Address 0xE5 [4:0]

Table 112. NVBEG Function

NVBEG	Description
00101 (default)	NTSC VSync begin position.

For all NTSC/PAL VSync timing controls, both the V bit in the AV code and the VSync on the VS pin are modified.

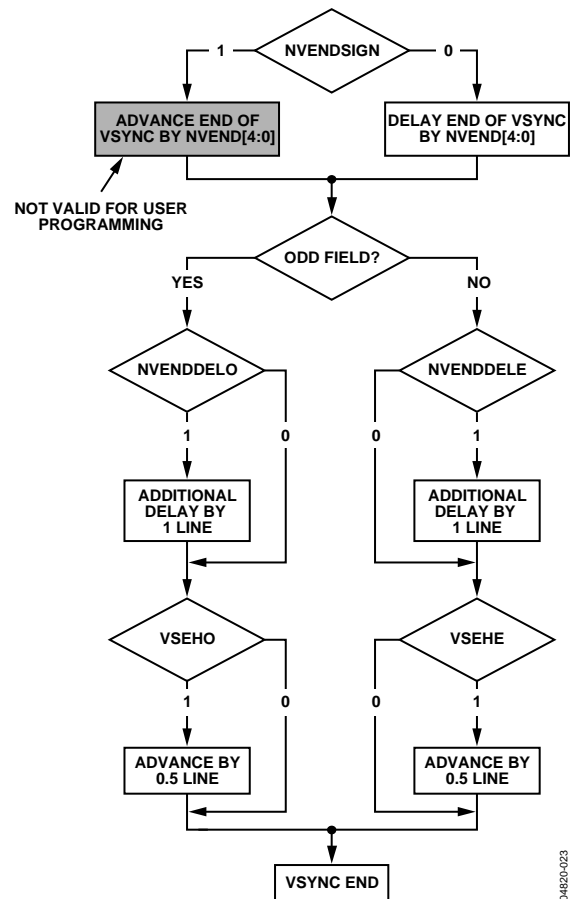

Figure 23. NTSC VSync End

NVENDDELO NTSC VSync End Delay on Odd Field, Address 0xE6 [7]

Address 0xE6 [7]

Table 113. NVENDDELO Function

NVENDDELO	Description
0 (default)	No delay.
1	Delay VSync going low on an odd field by a line relative to NVEND.

NVENDDELE NTSC VSync End Delay on Even Field, Address 0xE6 [6]

Address 0xE6 [6]

Table 114. NVENDDELE Function

NVENDDELE	Description
0 (default)	No delay.
1	Delay VSync going low on an even field by a line relative to NVEND

NVENDSIGN NTSC VSync End Sign, Address 0xE6 [5]

Table 115. NVENDSIGN Function

NVENDSIGN	Description
0 (default)	Delay end of VSync. Set for user manual programming.
1	Advance end of VSync. Not recommended for user programming.

NVEND NTSC[4:0] VSync End, Address 0xE6 [4:0]

Table 116. NVEND Function

NVEND	Description
00100 (default)	NTSC VSync end position.

For all NTSC/PAL VSync timing controls, both the V bit in the AV code and the VSync on the VS pin are modified.

NFTOGDELO NTSC Field Toggle Delay on Odd Field, Address 0xE7 [7]

Address 0xE7 [7]

Table 117. NFTOGDELO Function

NFTOGDELO	Description
0 (default)	No delay.
1	Delay Field toggle/transition on an odd field by a line relative to NFTOG.

NFTOGDELE NTSC Field Toggle Delay on Even Field, Address 0xE7 [6]

Address 0xE7 [6]

Table 118. NFTOGDELE Function

NFTOGDELE	Description
0	No delay.
1 (default)	Delay Field toggle/transition on an even field by a line relative to NFTOG.

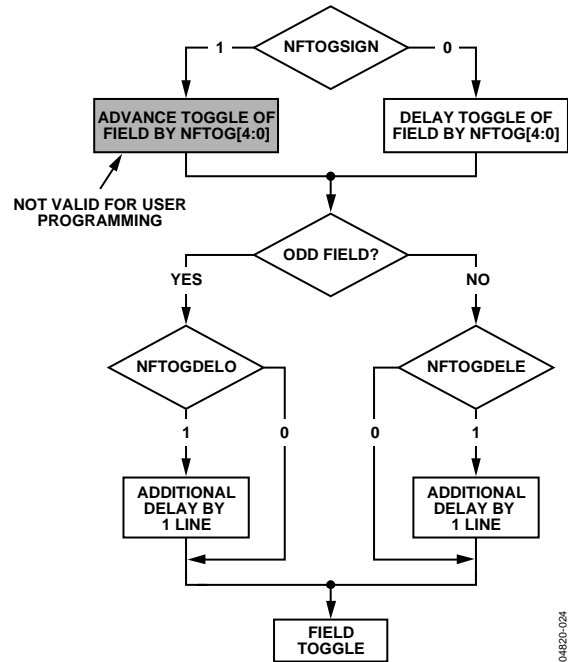

Figure 24. NTSC FIELD Toggle

NFTOGSIGN NTSC Field Toggle Sign, Address 0xE7 [5]

Table 119. NFTOGSIGN Function

NFTOGSIGN	Description
0	Delay field transition. Set for user manual programming.
1 (default)	Advance field transition. Not recommended for user programming.

NFTOG[4:0] NTSC Field Toggle, Address 0xE7 [4:0]

Table 120. NFTOG Function

NFTOG	Description
00011 (default)	NTSC Field toggle position.

For all NTSC/PAL Field timing controls, both the F bit in the AV code and the Field signal on the FIELD/DE pin are modified.

Table 121. Recommended User Settings for PAL (see Figure 26)

Register	Register Name	Write
0x31	VSync Field Control 1	0x12
0x32	VSync Field Control 2	0x81
0x33	VSync Field Control 3	0x84
0x37	Polarity	0x29
0xE8	PAL_V_Bit_Beg	0x1
0xE9	PAL_V_Bit_End	0x4
0xEA	PAL_F_Bit_Tog	0x6

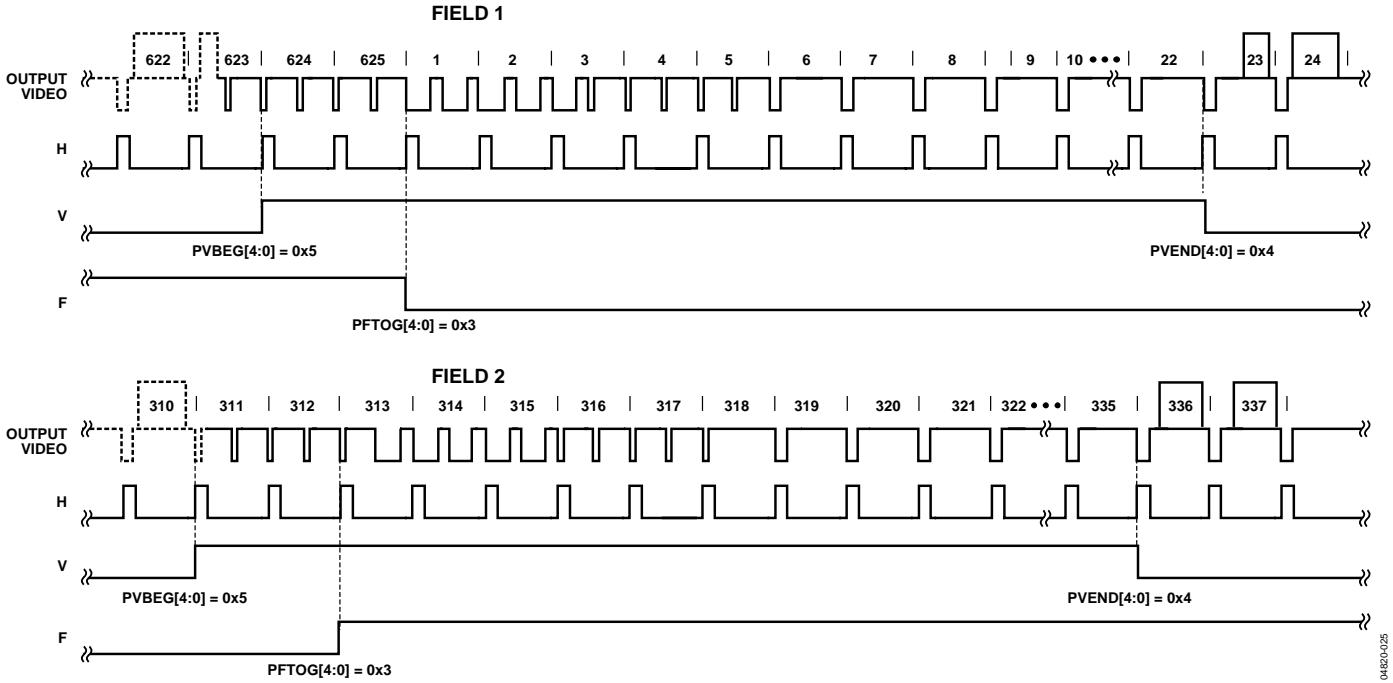

Figure 25. PAL Default (BT.656). The polarity of H, V, and F is embedded in the data.

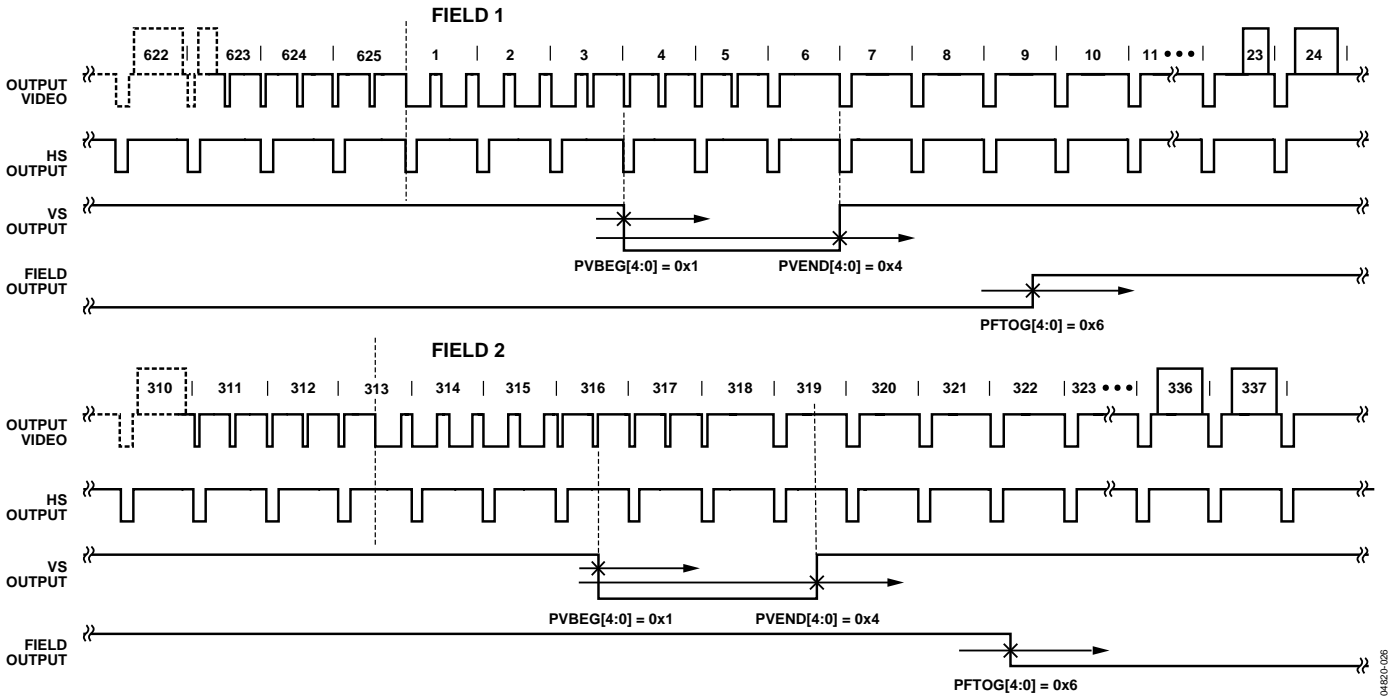

Figure 26. PAL Typical VSync/Field Positions Using Register Writes in Table 121

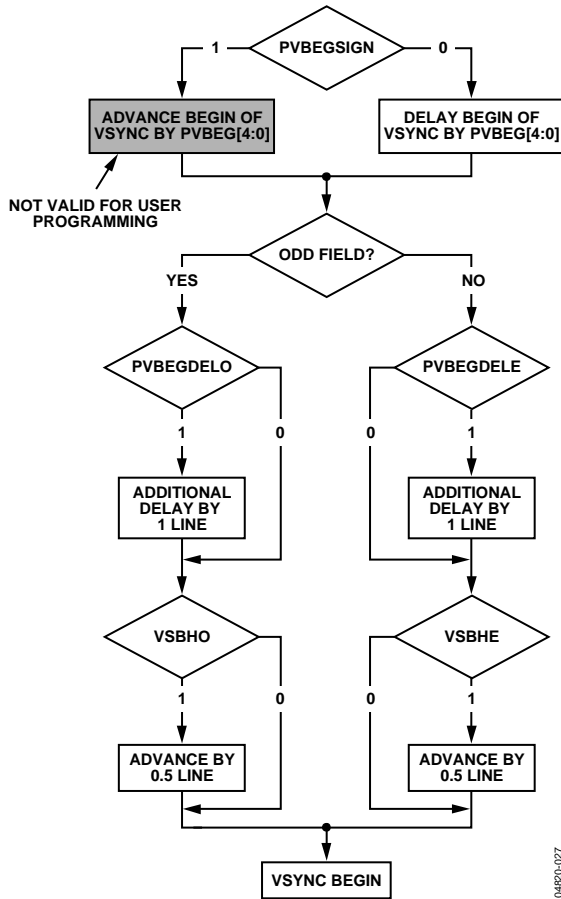

Figure 27. PAL VSync Begin

PVBEGDELO PAL VSync Begin Delay on Odd Field, Address 0xE8 [7]

Table 122. PVBEGDELO Function

PVBEGDELO	Description
0 (default)	No delay.
1	Delay VSync going high on an odd field by a line relative to PVBE.

PVBEGDELE PAL VSync Begin Delay on Even Field, Address 0xE8 [6]

Table 123. PVBEGDELE Function

PVBEGDELE	Description
0	No delay.
1 (default)	Delay VSync going high on an even field by a line relative to PVBE.

PVBEGSIGN PAL VSync Begin Sign, Address 0xE8 [5]

Table 124. PVBEGSIGN Function

PVBEGSIGN	Description
0	Delay begin of VSync. Set for user manual programming.
1 (default)	Advance begin of VSync. Not recommended for user programming.

PVBE[4:0] PAL VSync Begin, Address 0xE8 [4:0]

Table 125. PVBE Function

PVBE	Description
00101 (default)	PAL VSync begin position.

For all NTSC/PAL VSync timing controls, both the V bit in the AV code and the VSync on the VS pin are modified.

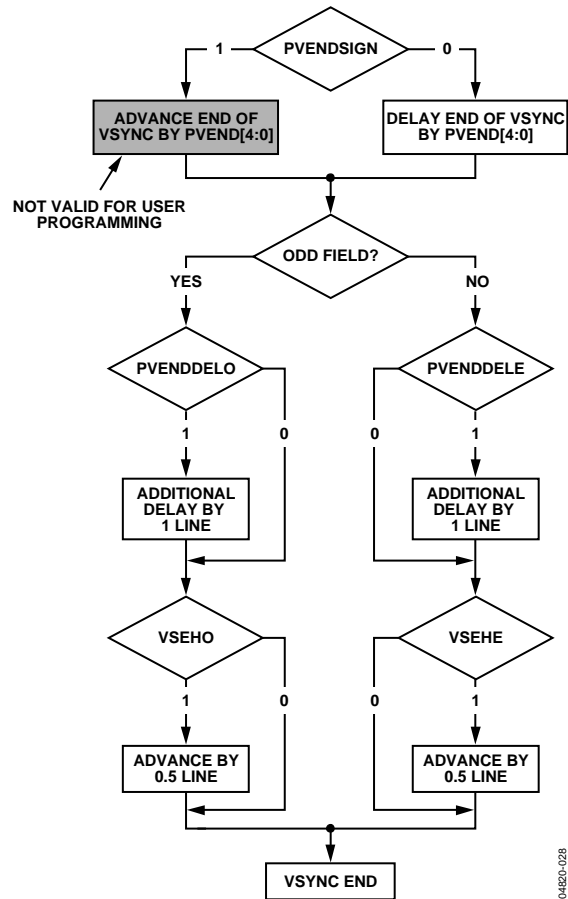

Figure 28. PAL VSync End

PVENDDELO PAL VSync End Delay on Odd Field, Address 0xE9 [7]

Table 126. PVENDDELO Function

PVENDDELO	Description
0 (default)	No delay.
1	Delay VSync going low on an odd field by a line relative to PVEND.

PVENDDELE PAL VSync End Delay on Even Field, Address 0xE9 [6]

Table 127. PVENDDELE Function

PVENDDELE	Description
0 (default)	No delay.
1	Delay VSync going low on an even field by a line relative to PVEND.

PVENDSIGN PAL VSync End Sign, Address 0xE9 [5]

Table 128. PVENDSIGN Function

PVENDSIGN	Description
0 (default)	Delay end of VSync. Set for user manual programming.
1	Advance end of VSync. Not recommended for user programming.

PVEND[4:0] PAL Vsync End, Address 0xE9,[4:0]

Table 129. PVEND Function

PVEND	Description
10100 (default)	PAL VSync end position.

For all NTSC/PAL VSync timing controls, both the V bit in the AV code and the VSync on the VS pin are modified.

PFTOGDELO PAL Field Toggle Delay on Odd Field, Address 0xEA [7]

Table 130. PFTOGDELO Function

PFTOGDELO	Description
0 (default)	No delay.
1	Delay F toggle/transition on an odd field by a line relative to PFTOG.

PFTOGDELE PAL Field Toggle Delay on Even Field, Address 0xEA [6]

Table 131. PFTOGDELE Function

PFTOGDELE	Description
0	No delay.
1 (default)	Delay F toggle/transition on an even field by a line relative to PFTOG.

PFTOGSIGN PAL Field Toggle Sign, Address 0xEA [5]

Table 132. PFTOGSIGN Function

PFTOGSIGN	Description
0	Delay Field transition. Set for user manual programming.
1 (default)	Advance Field transition. Not recommended for user programming.

PFTOG PAL Field Toggle, Address 0xEA [4:0]

Table 133. PFTOG Function

PFTOG	Description
00011 (default)	PAL Field toggle position.

For all NTSC/PAL Field timing controls, the F bit in the AV code and the Field signal on the FIELD/DE pin are modified.

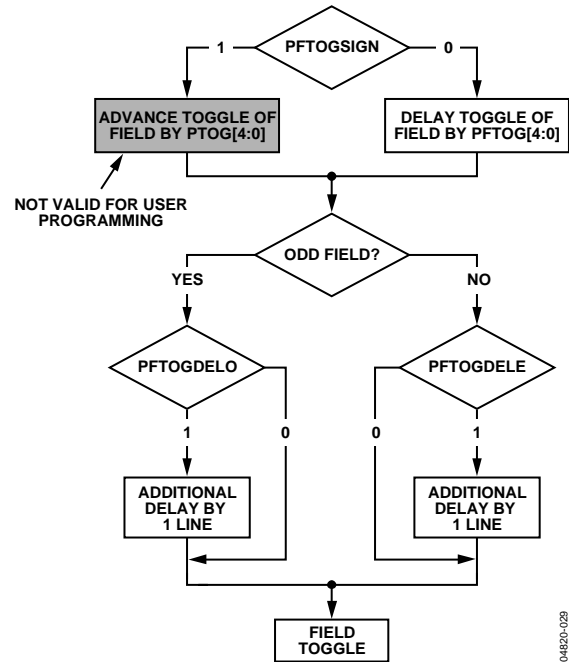

Figure 29. PAL F Toggle

SYNC PROCESSING

The ADV7181 has two additional sync processing blocks that postprocess the raw synchronization information extracted from the digitized input video. If desired, the blocks can be disabled via the following two I²C bits.

ENHSPLL Enable HSync Processor, Address 0x01 [6]

The HSYNC processor is designed to filter incoming HSyncs that have been corrupted by noise, providing improved performance for video signals with stable time bases but poor SNR.

For CVBS PAL/NTSC, YC PAL/NTSC, enable the HSync processor. For SECAM, disable the HSync processor. For YPrPb signals, disable Hsync processor.

Table 134. ENHSPLL Function

ENHSPLL	Description
0	Disable the HSync processor.
1 (default)	Enable the HSync processor.

ENVSPROC Enable VSync Processor, Address 0x01 [3]

This block provides extra filtering of the detected VSyncs to give improved vertical lock.

Table 135. ENVSPROC Function

ENVSPROC	Description
0	Disable VSync processor.
1 (default)	Enable VSync processor.

VBI DATA DECODE

The following low data rate VBI signals can be decoded by the ADV7181:

- Wide screen signaling (WSS)
- Copy generation management systems (CGMS)
- Closed captioning (CCAP)
- EDTV
- Gemstar 1×- and 2×-compatible data recovery

The presence of any of the above signals is detected and, if applicable, a parity check is performed. The result of this testing is contained in a confidence bit in the VBI Info[7:0] register. Users are encouraged to first examine the VBI Info register before reading the corresponding data registers. All VBI data decode bits are read-only.

All VBI data registers are double-buffered with the field signals. This means that data is extracted from the video lines and appears in the appropriate I²C registers with the next field transition. They are then static until the next field.

The user should start an I²C read sequence with VS by first examining the VBI Info register. Then, depending on the data detected, the appropriate data registers should be read.

The data registers are filled with decoded VBI data even if their corresponding detection bits are low; it is likely that bits within the decoded data stream are wrong.

Notes

- The closed captioning data (CCAP) is available in the I²C registers, and is also inserted into the output video data stream during horizontal blanking.
- The Gemstar-compatible data is not available in the I²C registers, and is inserted into the data stream only during horizontal blanking.

WSSD Wide Screen Signaling Detected, Address 0x90 [0]

Logic 1 for this bit indicates that the data in the WSS1 and WSS2 registers is valid.

The WSSD bit goes high if the rising edge of the start bit is detected within a time window, and if the polarity of the parity bit matches the data transmitted.

Table 136. WSSD Function

WSSD	Description
0	No WSS detected. Confidence in decoded data is low.
1	WSS detected. Confidence in decoded data is high.

CCAPD Closed Caption Detected, Address 0x90 [1]

Logic 1 for this bit indicates that the data in the CCAP1 and CCAP2 registers is valid.

The CCAPD bit goes high if the rising edge of the start bit is detected within a time window, and if the polarity of the parity bit matches the data transmitted.

Table 137. CCAPD Function

CCAPD	Description
0	No CCAP signals detected. Confidence in decoded data is low.
1	CCAP sequence detected. Confidence in decoded data is high.

EDTVD EDTV Sequence Detected, Address 0x90 [2]

Logic 1 for this bit indicates that the data in the EDTV1, 2, 3 registers is valid.

The EDTVD bit goes high if the rising edge of the start bit is detected within a time window, and if the polarity of the parity bit matches the data transmitted.

Table 138. EDTVD Function

EDTVD	Description
0	No EDTV sequence detected. Confidence in decoded data is low.
1	EDTV sequence detected. Confidence in decoded data is high.

CGMSD CGMS-A Sequence Detected, Address 0x90 [3]

Logic 1 for this bit indicates that the data in the CGMS1, 2, 3 registers is valid. The CGMSD bit goes high if a valid CRC checksum has been calculated from a received CGMS packet.

Table 139. CGMSD Function

CGMSD	Description
0	No CGMS transmission detected, confidence low.
1	CGMS sequence decoded, confidence high.

CRC_ENABLE CRC CGMS-A Sequence, Address 0xB2 [2]

For certain video sources, the CRC data bits may have an invalid format. In such circumstances, the CRC checksum validation procedure can be disabled. The CGMSD bit goes high if the rising edge of the start bit is detected within a time window.

Table 140. CRC_ENABLE Function

CRC_ENABLE	Description
0	No CRC check performed. The CGMSD bit goes high if the rising edge of the start bit is detected within a time window.
1 (default)	Use CRC checksum to validate the CGMS-A sequence. The CGMSD bit goes high for a valid checksum. ADI recommended setting.

Wide Screen Signaling Data

WSS1[7:0], Address 0x91 [7:0],
WSS2[7:0], Address 0x92 [7:0]

Figure 30 shows the bit correspondence between the analog video waveform and the WSS1/WSS2 registers. WSS2[7:6] are undetermined and should be masked out by software.

EDTV Data Registers

EDTV1[7:0], Address 0x93 [7:0],
EDTV2[7:0], Address 0x94 [7:0],
EDTV3[7:0], Address 0x95 [7:0]

Figure 31 shows the bit correspondence between the analog video waveform and the EDTV1/EDTV2/EDTV3 registers.

EDTV3[7:6] are undetermined and should be masked out by software. EDTV3[5] is reserved for future use and, for now, contains a 0. The three LSBs of the EDTV waveform are currently not supported.

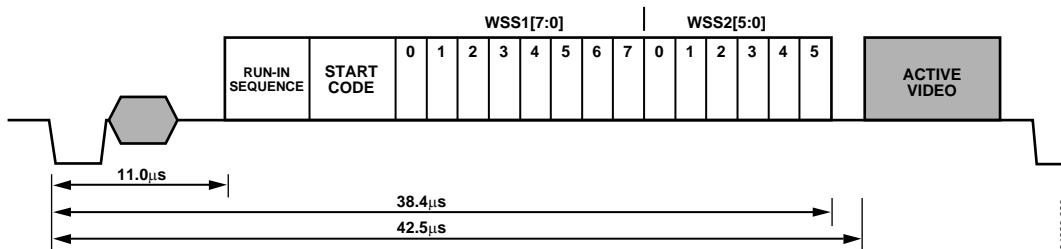

Figure 30. WSS Data Extraction

Table 141. WSS Access Information

Signal Name	Register Location	Address		Register Default Value
WSS1 [7:0]	WSS 1 [7:0]	145d	0x91	Readback Only
WSS2 [5:0]	WSS 2 [5:0]	146d	0x92	Readback Only

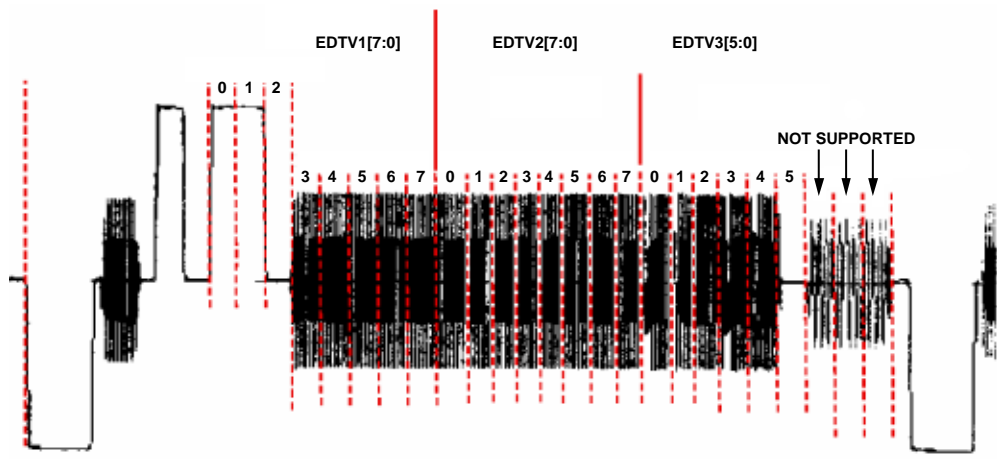

Figure 31. EDTV Data Extraction

Table 142. EDTV Access Information

Signal Name	Register Location	Address		Register Default Value
EDTV1[7:0]	EDTV 1 [7:0]	147d	0x93	Readback Only
EDTV2[7:0]	EDTV 2 [7:0]	148d	0x94	Readback Only
EDTV3[7:0]	EDTV 3 [7:0]	149d	0x95	Readback Only

CGMS Data Registers

CGMS1[7:0], Address 0x96 [7:0],
 CGMS2[7:0], Address 0x97 [7:0],
 CGMS3[7:0], Address 0x98 [7:0]

Figure 32 shows the bit correspondence between the analog video waveform and the CGMS1/CGMS2/CGMS3 registers. CGMS3[7:4] are undetermined and should be masked out by software.

Closed Caption Data Registers

CCAP1[7:0], Address 0x99 [7:0],
 CCAP2[7:0], Address 0x9A [7:0]

Figure 33 shows the bit correspondence between the analog video waveform and the CCAP1/CCAP2 registers.

Notes

- CCAP1[7] contains the parity bit from the first word. CCAP2[7] contains the parity bit from the second word.
- Refer to the GDECAD Gemstar Decode Ancillary Data Format, Address 0x4C [0] section.

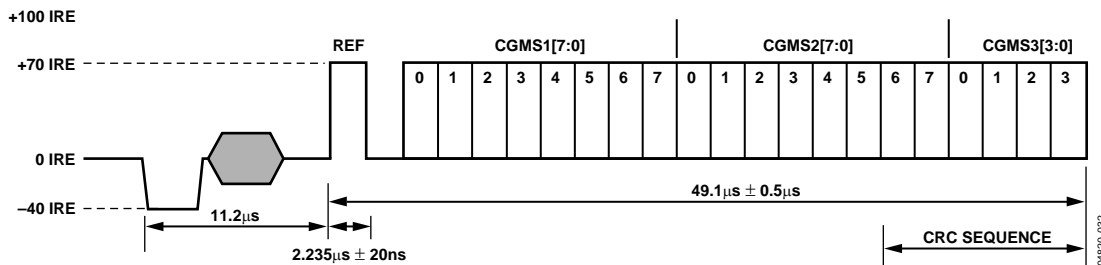

Figure 32. CGMS Data Extraction

Table 143. CGMS Access Information

Signal Name	Register Location	Address		Register Default Value
CGMS1[7:0]	CGMS 1 [7:0]	150d	0x96	Readback Only
CGMS2[7:0]	CGMS 2 [7:0]	151d	0x97	Readback Only
CGMS3[3:0]	CGMS 3 [3:0]	152d	0x98	Readback Only

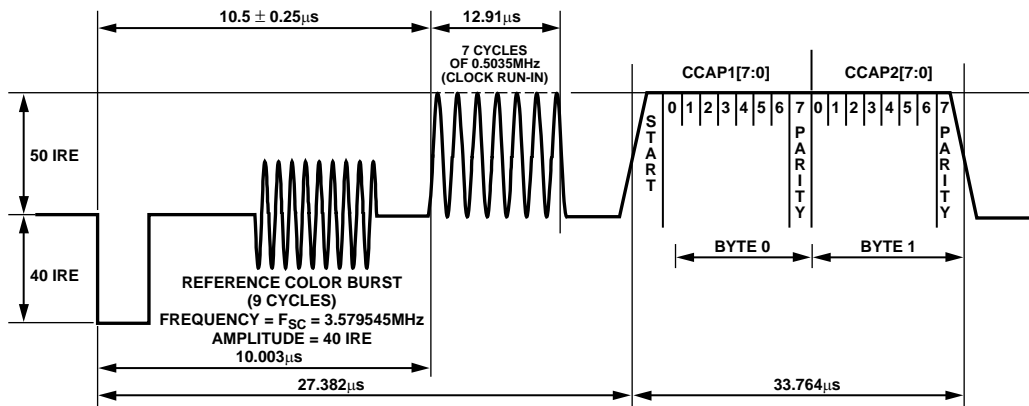

Figure 33. Closed Caption Data Extraction

Table 144. CCAP Access Information

Signal Name	Register Location	Address		Register Default Value
CCAP1[7:0]	CCAP 1 [7:0]	153d	0x99	Readback Only
CCAP2[7:0]	CCAP 2 [7:0]	154d	0x9A	Readback Only

Letterbox Detection

Incoming video signals may conform to different aspect ratios (16:9 wide screen of 4:3 standard). For certain transmissions in the wide screen format, a digital sequence (WSS) is transmitted with the video signal. If a WSS sequence is provided, the aspect ratio of the video can be derived from the digitally decoded bits WSS contains.

In the absence of a WSS sequence, letterbox detection can be used to find wide screen signals. The detection algorithm examines the active video content of lines at the start and end of a field. The detection of black lines can indicate that the currently shown picture is in wide screen format.

The active video content (luminance magnitude) over a line of video is summed together. At the end of a line, this accumulated value is compared with a threshold, and a decision is made as to whether or not a particular line is black. The threshold value needed may depend on the type of input signal; some control is provided via LB_TH[4:0].

Detection at the Start of a Field

The ADV7181 expects a section of at least six consecutive black lines of video at the top of a field. Once those lines have been detected, Register LB_LCT[7:0] reports back the number of black lines that were actually found. By default, the ADV7181 starts looking for those black lines in sync with the beginning of active video, for example, straight after the last VBI video line. LB_SL[3:0] allows the user to set the start of letterbox detection from the beginning of a frame on a line-by-line basis. The detection window closes in the middle of the field.

Detection at the End of a Field

The ADV7181 expects at least six continuous lines of black video at the bottom of a field before reporting back the number of lines actually found via the LB_LCB[7:0] value. The activity window for letterbox detection (end of field) starts in the middle of an active field. Its end is programmable via LB_EL[3:0].

Detection at the Midrange

Some transmissions of wide screen video include subtitles within the lower black box. If the ADV7181 finds at least two black lines followed by some more nonblack video, for example, the subtitle, and finally followed by the remainder of the bottom black block, it reports back a midcount via LB_LCM[7:0]. When no subtitles are found, LB_LCM[7:0] reports the same number as LB_LCB[7:0].

Notes

- There is a 2-field delay in the reporting of any line count parameters.
- There is no "letterbox detected" bit. The user is asked to read the LB_LCT[7:0] and LB_LCB[7:0] register values and

to come to a conclusion about the presence of letterbox type video in software.

LB_LCT[7:0] Letterbox Line Count Top, Address 0x9B [7:0];
LB_LCM[7:0] Letterbox Line Count Mid, Address 0x9C [7:0];
LB_LCB[7:0] Letterbox Line Count Bottom,
Address 0x9D [7:0]

Table 145. LB_LCx Access Information

Signal Name	Address	Register Default Value
LB_LCT[7:0]	0x9B	Readback only
LB_LCM[7:0]	0x9C	Readback only
LB_LCB[7:0]	0x9D	Readback only

LB_TH[4:0] Letterbox Threshold Control, Address 0xDC [4:0]

Table 146. LB_TH Function

LB_TH[4:0]	Description
01100 (default)	Default threshold for detection of black lines.
01101 to 10000	Increase threshold (need larger active video content before identifying non-black lines).
00000 to 01011	Decrease threshold (even small noise levels can cause the detection of non-black lines).

LB_SL[3:0] Letterbox Start Line, Address 0xDD [7:4]

Table 147. LB_SL Function

LB_SL[3:0]	Description
0100 (default)	Letterbox detection is aligned with active video. Window starts after the EDTV VBI data line. For example, 0100 = 23/286 (NTSC).
0001, 0010	For example, 0101 = 24/287 (NTSC).

LB_EL[3:0] Letterbox End Line, Address 0xDD [3:0]

Table 148. LB_EL Function

LB_EL[3:0]	Description
1101 (default)	Letterbox detection ends with the last active line of video on a field. For example, 1101 = 262/ 525 (NTSC).
0001,0010	For example, 1100 = 261/524 (NTSC).

Gemstar Data Recovery

The Gemstar-compatible data recovery block (GSCD) supports 1× and 2× data transmissions. In addition, it can also serve as a closed caption decoder. Gemstar-compatible data transmissions can only occur in NTSC. Closed caption data can be decoded in both PAL and NTSC.

The block is configured via I²C in the following way:

- GDECEL[15:0] allow data recovery on selected video lines on even fields to be enabled and disabled.
- GDECOL[15:0] enable the data recovery on selected lines for odd fields.

- GDECAD configures the way in which data is embedded in the video data stream. The recovered data is not available through I²C, but is inserted into the horizontal blanking period of an ITU-R. BT656-compatible data stream. The data format is intended to comply with the recommendation by the International Telecommunications Union, ITU-R BT.1364. See Figure 34. For more information, see the ITU website at www.itu.ch.

The format of the data packet depends on the following criteria:

- Transmission is 1× or 2×.
- Data is output in 8-bit or 4-bit format (see the description of the GDECAD Gemstar Decode Ancillary Data Format, Address 0x4C [0] bit).
- Data is closed caption (CCAP) or Gemstar-compatible.

Data packets are output if the corresponding enable bit is set (see the GDECEL and GDECOL descriptions) and if the decoder detects the presence of data. This means that for video lines where no data has been decoded, no data packet is output even if the corresponding line enable bit is set.

Each data packet starts immediately after the EAV code of the preceding line. See Figure 34 and Table 149, which show the overall structure of the data packet.

Entries within the packet are as follows:

- Fixed preamble sequence of 0x00, 0xFF, 0xFF.
- Data identification word (DID). The value for the DID marking a Gemstar or CCAP data packet is 0x140 (10-bit value).
- Secondary data identification word (SDID), which contains information about the video line from which data was retrieved, whether the Gemstar transmission was of 1× or 2× format, and whether it was retrieved from an even or odd field.
- Data count byte, giving the number of user data-words that follow.
- User data section.
- Optional padding to ensure that the length of the user data-word section of a packet is a multiple of four bytes. (Requirement as set in ITU-R BT.1364.)
- Checksum byte.

Table 149 lists the values within a generic data packet that is output by the ADV7181 in 8-bit format. In 8-bit systems, Bits D1 and D0 in the data packets are disregarded.

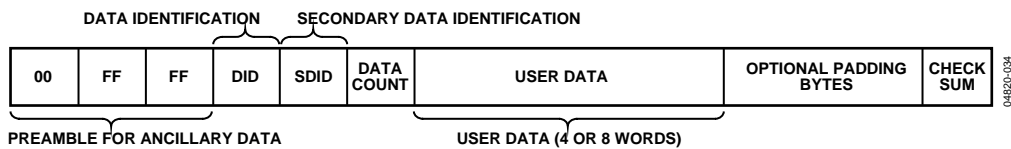

Figure 34. Gemstar and CCAP Embedded Data Packet (Generic)

Table 149. Generic Data Output Packet

Byte	D[9]	D[8]	D[7]	D[6]	D[5]	D[4]	D[3]	D[2]	D[1]	D[0]	Description
0	0	0	0	0	0	0	0	0	0	0	Fixed preamble
1	1	1	1	1	1	1	1	1	1	1	Fixed preamble
2	1	1	1	1	1	1	1	1	1	1	Fixed preamble
3	0	1	0	1	0	0	0	0	0	0	DID
4	!EP	EP	EF	2X	line[3:0]				0	0	SDID
5	!EP	EP	0	0	0	0	DC[1]	DC[0]	0	0	Data count (DC)
6	!EP	EP	0	0	word1[7:4]				0	0	User data-words
7	!EP	EP	0	0	word1[3:0]				0	0	User data-words
8	!EP	EP	0	0	word2[7:4]				0	0	User data-words
9	!EP	EP	0	0	word2[3:0]				0	0	User data-words
10	!EP	EP	0	0	word3[7:4]				0	0	User data-words
11	!EP	EP	0	0	word3[3:0]				0	0	User data-words
12	!EP	EP	0	0	word4[7:4]				0	0	User data-words
13	!EP	EP	0	0	word4[3:0]				0	0	User data-words
14	!CS[8]	CS[8]	CS[7]	CS[6]	CS[5]	CS[4]	CS[3]	CS[2]	0	0	Checksum

Table 150. Data Byte Allocation

2x	Raw Information Bytes Retrieved from the Video Line	GDECAD	User Data-Words (Including Padding)	Padding Bytes	DC[1:0]
1	4	0	8	0	10
1	4	1	4	0	01
0	2	0	4	0	01
0	2	1	4	2	01

Notes

- DID. The data identification value is 0x140 (10-bit value). Care has been taken that in 8-bit systems, the 2 LSBs do not carry vital information.
- EP and !EP. The EP bit is set to ensure even parity on the data-word D[8:0]. Even parity means there is always an even number of 1s within the D[8:0] bit arrangement. This includes the EP bit. !EP describes the logic inverse of EP and is output on D[9]. The !EP is output to ensure that the reserved codes of 00 and FF cannot happen.
- EF. Even field identifier. EF = 1 indicates that the data was recovered from a video line on an even field.
- 2X. This bit indicates whether the data sliced was in Gemstar 1x or 2x format. A high indicates 2x format.
- line[3:0]. This entry provides a code that is unique for each of the possible 16 source lines of video from which Gemstar data may have been retrieved. Refer to Table 162 and Table 163.
- DC[1:0]. Data count value. The number of user data-words in the packet divided by 4. The number of user data-words (UDW) in any packet must be an integral number of 4. Padding is required at the end, if necessary. (Requirement as set in ITU-R BT.1364.) Refer to Table 150.
- The 2X bit determines whether the raw information retrieved from the video line was 2 or 4 bytes. The state of the GDECAD bit affects whether the bytes are transmitted straight (that is, two bytes transmitted as two bytes) or whether they are split into nibbles (that is, two bytes transmitted as four half bytes). Padding bytes are then added where necessary.
- CS[8:2]. The checksum is provided to determine the integrity of the ancillary data packet. It is calculated by summing up D[8:2] of DID, SDID, the Data Count byte, and all UDWs, and ignoring any overflow during the summation. Since all data bytes that are used to calculate the checksum have their 2 LSBs set to 0, the CS[1:0] bits are also always 0.

!CS[8] describes the logic inversion of CS[8]. The value !CS[8] is included in the checksum entry of the data packet to ensure that the reserved values of 0x00 and 0xFF do not occur.

Table 151 to Table 154 outline the possible data packages.

Gemstar 2x Format, Half-Byte Output Mode

Half-byte output mode is selected by setting CDECAD = 0; full-byte output mode is selected by setting CDECAD = 1. See the GDECAD Gemstar Decode Ancillary Data Format, Address 0x4C [0] section.

Gemstar 1x Format

Half-byte output mode is selected by setting CDECAD = 0; full-byte output mode is selected by setting CDECAD = 1. See the GDECAD Gemstar Decode Ancillary Data Format, Address 0x4C [0] section.

Table 151. Gemstar 2× Data, Half-Byte Mode

Byte	D[9]	D[8]	D[7]	D[6]	D[5]	D[4]	D[3]	D[2]	D[1]	D[0]	Description
0	0	0	0	0	0	0	0	0	0	0	Fixed preamble
1	1	1	1	1	1	1	1	1	1	1	Fixed preamble
2	1	1	1	1	1	1	1	1	1	1	Fixed preamble
3	0	1	0	1	0	0	0	0	0	0	DID
4	!EP	EP	EF	1	line[3:0]				0	0	SDID
5	!EP	EP	0	0	0	0	1	0	0	0	Data count
6	!EP	EP	0	0	Gemstar word1[7:4]				0	0	User data-words
7	!EP	EP	0	0	Gemstar word1[3:0]				0	0	User data-words
8	!EP	EP	0	0	Gemstar word2[7:4]				0	0	User data-words
9	!EP	EP	0	0	Gemstar word2[3:0]				0	0	User data-words
10	!EP	EP	0	0	Gemstar word3[7:4]				0	0	User data-words
11	!EP	EP	0	0	Gemstar word3[3:0]				0	0	User data-words
12	!EP	EP	0	0	Gemstar word4[7:4]				0	0	User data-words
13	!EP	EP	0	0	Gemstar word4[3:0]				0	0	User data-words
14	!CS[8]	CS[8]	CS[7]	CS[6]	CS[5]	CS[4]	CS[3]	CS[2]	CS[1]	CS[0]	Checksum

Table 152. Gemstar 2× Data, Full-Byte Mode

Byte	D[9]	D[8]	D[7]	D[6]	D[5]	D[4]	D[3]	D[2]	D[1]	D[0]	Description
0	0	0	0	0	0	0	0	0	0	0	Fixed preamble
1	1	1	1	1	1	1	1	1	1	1	Fixed preamble
2	1	1	1	1	1	1	1	1	1	1	Fixed preamble
3	0	1	0	1	0	0	0	0	0	0	DID
4	!EP	EP	EF	1	line[3:0]				0	0	SDID
5	!EP	EP	0	0	0	0	0	1	0	0	Data count
6	Gemstar word1[7:0]								0	0	User data-words
7	Gemstar word2[7:0]								0	0	User data-words
8	Gemstar word3[7:0]								0	0	User data-words
9	Gemstar word4[7:0]								0	0	User data-words
10	!CS[8]	CS[8]	CS[7]	CS[6]	CS[5]	CS[4]	CS[3]	CS[2]	CS[1]	CS[0]	Checksum

Table 153. Gemstar 1× Data, Half-Byte Mode

Byte	D[9]	D[8]	D[7]	D[6]	D[5]	D[4]	D[3]	D[2]	D[1]	D[0]	Description
0	0	0	0	0	0	0	0	0	0	0	Fixed preamble
1	1	1	1	1	1	1	1	1	1	1	Fixed preamble
2	1	1	1	1	1	1	1	1	1	1	Fixed preamble
3	0	1	0	1	0	0	0	0	0	0	DID
4	!EP	EP	EF	0	line[3:0]				0	0	SDID
5	!EP	EP	0	0	0	0	0	1	0	0	Data count
6	!EP	EP	0	0	Gemstar word1[7:4]				0	0	User data-words
7	!EP	EP	0	0	Gemstar word1[3:0]				0	0	User data-words
8	!EP	EP	0	0	Gemstar word2[7:4]				0	0	User data-words
9	!EP	EP	0	0	Gemstar word2[3:0]				0	0	User data-words
10	!CS[8]	CS[8]	CS[7]	CS[6]	CS[5]	CS[4]	CS[3]	CS[2]	CS[1]	CS[0]	Checksum

Table 154. Gemstar 1× Data, Full-Byte Mode

Byte	D[9]	D[8]	D[7]	D[6]	D[5]	D[4]	D[3]	D[2]	D[1]	D[0]	Description
0	0	0	0	0	0	0	0	0	0	0	Fixed preamble
1	1	1	1	1	1	1	1	1	1	1	Fixed preamble
2	1	1	1	1	1	1	1	1	1	1	Fixed preamble
3	0	1	0	1	0	0	0	0	0	0	DID
4	!EP	EP	EF	0	line[3:0]				0	0	SDID
5	!EP	EP	0	0	0	0	0	1	0	0	Data count
6	Gemstar word1[7:0]								0	0	User data-words
7	Gemstar word2[7:0]								0	0	User data-words
8	1	0	0	0	0	0	0	0	0	0	UDW padding 200h
9	1	0	0	0	0	0	0	0	0	0	UDW padding 200h
10	!CS[8]	CS[8]	CS[7]	CS[6]	CS[5]	CS[4]	CS[3]	CS[2]	CS[1]	CS[0]	Checksum

Table 155. NTSC CCAP Data, Half-Byte Mode

Byte	D[9]	D[8]	D[7]	D[6]	D[5]	D[4]	D[3]	D[2]	D[1]	D[0]	Description
0	0	0	0	0	0	0	0	0	0	0	Fixed preamble
1	1	1	1	1	1	1	1	1	1	1	Fixed preamble
2	1	1	1	1	1	1	1	1	1	1	Fixed preamble
3	0	1	0	1	0	0	0	0	0	0	DID
4	!EP	EP	EF	0	1	0	1	1	0	0	SDID
5	!EP	EP	0	0	0	0	0	1	0	0	Data count
6	!EP	EP	0	0	CCAP word1[7:4]				0	0	User data-words
7	!EP	EP	0	0	CCAP word1[3:0]				0	0	User data-words
8	!EP	EP	0	0	CCAP word2[7:4]				0	0	User data-words
9	!EP	EP	0	0	CCAP word2[3:0]				0	0	User data-words
10	!CS[8]	CS[8]	CS[7]	CS[6]	CS[5]	CS[4]	CS[3]	CS[2]	CS[1]	CS[0]	Checksum

Table 156. NTSC CCAP Data, Full-Byte Mode

Byte	D[9]	D[8]	D[7]	D[6]	D[5]	D[4]	D[3]	D[2]	D[1]	D[0]	Description
0	0	0	0	0	0	0	0	0	0	0	Fixed preamble
1	1	1	1	1	1	1	1	1	1	1	Fixed preamble
2	1	1	1	1	1	1	1	1	1	1	Fixed preamble
3	0	1	0	1	0	0	0	0	0	0	DID
4	!EP	EP	EF	0	1	0	1	1	0	0	SDID
5	!EP	EP	0	0	0	0	0	1	0	0	Data count
6	CCAP word1[7:0]								0	0	User data-words
7	CCAP word2[7:0]								0	0	User data-words
8	1	0	0	0	0	0	0	0	0	0	UDW padding 200h
9	1	0	0	0	0	0	0	0	0	0	UDW padding 200h
10	!CS[8]	CS[8]	CS[7]	CS[6]	CS[5]	CS[4]	CS[3]	CS[2]	CS[1]	CS[0]	Checksum

NTSC CCAP Data

Half-byte output mode is selected by setting CDECAD = 0; the full-byte mode is enabled by CDECAD = 1. Refer to the GDECAD Gemstar Decode Ancillary Data Format, Address 0x4C [0] section. The data packet formats are shown in Table 155 and Table 156.

Notes

- NTSC closed caption data is sliced on line 21d on even and odd fields. The corresponding enable bit has to be set high. See the GDECEL[15:0] Gemstar Decoding Even Lines, Address 0x48 [7:0]; Address 0x49 [7:0] and GDECOL[15:0] Gemstar Decoding Odd Lines, Address 0x4A [7:0]; Address 0x4B [7:0] sections.

ADV7181

PAL CCAP Data

Half-Byte output mode is selected by setting CDECAD = 0, full-byte output mode is selected by setting CDECAD = 1. See the GDECAD Gemstar Decode Ancillary Data Format, Address 0x4C [0] section. Table 157 and Table 158 list the bytes of the data packet.

Notes

- PAL closed caption data is sliced from Lines 22 and 335. The corresponding enable bits have to be set.
- See the GDECEL[15:0] Gemstar Decoding Even Lines, Address 0x48 [7:0]; Address 0x49 [7:0] and GDECOL[15:0] Gemstar Decoding Odd Lines, Address 0x4A [7:0]; Address 0x4B [7:0] sections.

Table 157. PAL CCAP Data, Half-Byte Mode

Byte	D[9]	D[8]	D[7]	D[6]	D[5]	D[4]	D[3]	D[2]	D[1]	D[0]	Description
0	0	0	0	0	0	0	0	0	0	0	Fixed preamble
1	1	1	1	1	1	1	1	1	1	1	Fixed preamble
2	1	1	1	1	1	1	1	1	1	1	Fixed preamble
3	0	1	0	1	0	0	0	0	0	0	DID
4	!EP	EP	EF	0	1	0	1	0	0	0	SDID
5	!EP	EP	0	0	0	0	0	1	0	0	Data count
6	!EP	EP	0	0	CCAP word1[7:4]				0	0	User data-words
7	!EP	EP	0	0	CCAP word1[3:0]				0	0	User data-words
8	!EP	EP	0	0	CCAP word2[7:4]				0	0	User data-words
9	!EP	EP	0	0	CCAP word2[3:0]				0	0	User data-words
10	!CS[8]	CS[8]	CS[7]	CS[6]	CS[5]	CS[4]	CS[3]	CS[2]	CS[1]	CS[0]	Checksum

Table 158. PAL CCAP Data, Full-Byte Mode

Byte	D[9]	D[8]	D[7]	D[6]	D[5]	D[4]	D[3]	D[2]	D[1]	D[0]	Description
0	0	0	0	0	0	0	0	0	0	0	Fixed preamble
1	1	1	1	1	1	1	1	1	1	1	Fixed preamble
2	1	1	1	1	1	1	1	1	1	1	Fixed preamble
3	0	1	0	1	0	0	0	0	0	0	DID
4	!EP	EP	EF	0	1	0	1	0	0	0	SDID
5	!EP	EP	0	0	0	0	0	1	0	0	Data Count
6	CCAP word1[7:0]								0	0	User data-words
7	CCAP word2[7:0]								0	0	User data-words
8	1	0	0	0	0	0	0	0	0	0	UDW padding 200h
9	1	0	0	0	0	0	0	0	0	0	UDW padding 200h
10	!CS[8]	CS[8]	CS[7]	CS[6]	CS[5]	CS[4]	CS[3]	CS[2]	CS[1]	CS[0]	Checksum

**GDECEL[15:0] Gemstar Decoding Even Lines,
Address 0x48 [7:0]; Address 0x49 [7:0]**

The 16 bits of the GDECEL[15:0] are interpreted as a collection of 16 individual line decode enable signals. Each bit refers to a line of video in an even field. Setting the bit enables the decoder block trying to find Gemstar- or closed caption-compatible data on that particular line. Setting the bit to 0 prevents the decoder from trying to retrieve data. See Table 162 and Table 163.

Notes

- To retrieve closed caption data services on NTSC (Line 284), GDECEL[11] must be set.
- To retrieve closed caption data services on PAL (Line 335), GDECEL[14] must be set.

Table 159. GDECEL Function

GDECEL[15:0]	Description
0x0000 (default)	Do not attempt to decode Gemstar-compatible data or CCAP on any line (even field).

**GDECOL[15:0] Gemstar Decoding Odd Lines,
Address 0x4A [7:0]; Address 0x4B [7:0]**

The 16 bits of the GDECOL[15:0] form a collection of 16 individual line decode enable signals. See Table 162 and Table 163.

Notes

- To retrieve closed caption data services on NTSC (Line 21), GDECOL[11] must be set.
- To retrieve closed caption data services on PAL (Line 22), GDECOL[14] must be set.

Table 160. GDECOL Function

GDECOL[15:0]	Description
0x0000 (default)	Do not attempt to decode Gemstar-compatible data or CCAP on any line (odd field).

**GDECAD Gemstar Decode Ancillary Data Format,
Address 0x4C [0]**

The decoded data from Gemstar-compatible transmissions or closed caption is inserted into the horizontal blanking period of the respective line of video. There is a potential problem if the retrieved data bytes have the value 0x00 or 0xFF. In an ITU-R BT.656-compatible data stream, those values are reserved and used only to form a fixed preamble.

The GDECAD bit allows the data to be inserted into the horizontal blanking period in two ways:

- Insert all data straight into the data stream, even the reserved values of 0x00 and 0xFF, if they occur. This may violate the output data format specification ITU-R BT.1364.
- Split all data into nibbles and insert the half-bytes over double the number of cycles in a 4-bit format.

Table 161. GDECAD Function

GDECAD	Description
0 (default)	Split data into half-bytes and insert.
1	Output data straight in 8-bit format.

Table 162. NTSC Line Enable Bits and Corresponding Line Numbering

line[3:0]	Line Number (ITU-R BT.470)	Enable Bit	Comment
0	10	GDECOL[0]	Gemstar
1	11	GDECOL[1]	Gemstar
2	12	GDECOL[2]	Gemstar
3	13	GDECOL[3]	Gemstar
4	14	GDECOL[4]	Gemstar
5	15	GDECOL[5]	Gemstar
6	16	GDECOL[6]	Gemstar
7	17	GDECOL[7]	Gemstar
8	18	GDECOL[8]	Gemstar
9	19	GDECOL[9]	Gemstar
10	20	GDECOL[10]	Gemstar
11	21	GDECOL[11]	Gemstar or closed caption
12	22	GDECOL[12]	Gemstar
13	23	GDECOL[13]	Gemstar
14	24	GDECOL[14]	Gemstar
15	25	GDECOL[15]	Gemstar
0	273 (10)	GDECEL[0]	Gemstar
1	274 (11)	GDECEL[1]	Gemstar
2	275 (12)	GDECEL[2]	Gemstar
3	276 (13)	GDECEL[3]	Gemstar
4	277 (14)	GDECEL[4]	Gemstar
5	278 (15)	GDECEL[5]	Gemstar
6	279 (16)	GDECEL[6]	Gemstar
7	280 (17)	GDECEL[7]	Gemstar
8	281 (18)	GDECEL[8]	Gemstar
9	282 (19)	GDECEL[9]	Gemstar
10	283 (20)	GDECEL[10]	Gemstar
11	284 (21)	GDECEL[11]	Gemstar or closed caption
12	285 (22)	GDECEL[12]	Gemstar
13	286 (23)	GDECEL[13]	Gemstar
14	287 (24)	GDECEL[14]	Gemstar
15	288 (25)	GDECEL[15]	Gemstar

Table 163. PAL Line Enable Bits and Corresponding Line Numbering

line[3:0]	Line Number (ITU-R BT.470)	Enable Bit	Comment
12	8	GDECOL[0]	Not valid
13	9	GDECOL[1]	Not valid
14	10	GDECOL[2]	Not valid
15	11	GDECOL[3]	Not valid
0	12	GDECOL[4]	Not valid
1	13	GDECOL[5]	Not valid
2	14	GDECOL[6]	Not valid
3	15	GDECOL[7]	Not valid
4	16	GDECOL[8]	Not valid
5	17	GDECOL[9]	Not valid
6	18	GDECOL[10]	Not valid
7	19	GDECOL[11]	Not valid
8	20	GDECOL[12]	Not valid
9	21	GDECOL[13]	Not valid
10	22	GDECOL[14]	Closed caption
11	23	GDECOL[15]	Not valid
12	321 (8)	GDECEL[0]	Not valid
13	322 (9)	GDECEL[1]	Not valid
14	323 (10)	GDECEL[2]	Not valid
15	324 (11)	GDECEL[3]	Not valid
0	325 (12)	GDECEL[4]	Not valid
1	326 (13)	GDECEL[5]	Not valid
2	327 (14)	GDECEL[6]	Not valid
3	328 (15)	GDECEL[7]	Not valid
4	329 (16)	GDECEL[8]	Not valid
5	330 (17)	GDECEL[9]	Not valid
6	331 (18)	GDECEL[10]	Not valid
7	332 (19)	GDECEL[11]	Not valid
8	333 (20)	GDECEL[12]	Not valid
9	334 (21)	GDECEL[13]	Not valid
10	335 (22)	GDECEL[14]	Closed caption
11	336 (23)	GDECEL[15]	Not valid

PIXEL PORT CONFIGURATION

The ADV7181 has a very flexible pixel port that can be configured in a variety of formats to accommodate downstream ICs. Table 166 and Table 167 summarize the various functions that the ADV7181's pins can have in different modes of operation.

The ordering of components, for example, Cr vs. Cb, CHA/B/C, can be changed. Refer to the SWPC Swap Pixel Cr/Cb, Address 0x27 [7] section. Table 166 indicates the default positions for the Cr/Cb components.

OF_SEL[3:0] Output Format Selection, Address 0x03 [5:2]

There are several modes in which the ADV7181 pixel port can be configured. These modes are under the control of OF_SEL[3:0]. See Table 167 for details.

The default LLC frequency output on the LLC1 pin is approximately 27 MHz. For modes that operate with a nominal data rate of 13.5 MHz (0001, 0010), the clock frequency on the LLC1 pin stays at the higher rate of 27 MHz. For information on outputting the nominal 13.5 MHz clock on the LLC1 pin, see the LLC1 Output Selection, LLC_PAD_SEL[2:0], Address 0x8F [6:4] section.

SWPC Swap Pixel Cr/Cb, Address 0x27 [7]

This bit allows Cr and Cb samples to be swapped.

Table 164. SWPC Function

SWPC	Description
0 (default)	No swapping.
1	Swap Cr and Cb values.

LLC1 Output Selection, LLC_PAD_SEL[2:0], Address 0x8F [6:4]

The following I²C write allows the user to select between the LLC1 (nominally at 27 MHz) and LLC2 (nominally at 13.5 MHz).

The LLC2 signal is useful for LLC2-compatible wide bus (16-bit) output modes. See the OF_SEL[3:0] Output Format Selection, Address 0x03 [5:2] section for additional information. The LLC2 signal and data on the data bus are synchronized. By default, the rising edge of LLC1/LLC2 is aligned with the Y data; the falling edge occurs when the data bus holds C data. The polarity of the clock, and therefore the Y/C assignments to the clock edges, can be altered by using the Polarity LLC pin.

Table 165. LLC_PAD_SEL Function

LLC_PAD_SEL[2:0]	Description
000 (default)	Output nominal 27 MHz LLC on LLC1 pin.
101	Output nominal 13.5 MHz LLC on LLC1 pin.

Table 166. P15–P0 Output/Input Pin Mapping

Processor, Format, and Mode	Data Port Pins P[15:0]																
	15	14	13	12	11	10	9	8	7	6	5	4	3	2	1	0	
Video Out, 8-Bit, 4:2:2	YCrCb[7:0]OUT																
Video Out, 16-Bit, 4:2:2	Y[7:0]OUT								CrCb[7:0] OUT								

Table 167. Standard Definition Pixel Port Modes

OF_SEL[3:0]	Format	P[15:0]	
		P[15:8]	P[7:0]
0010	16-Bit @ LLC2 4:2:2	Y[7:0]	CrCb[7:0]
0011 (default)	8-Bit @ LLC1 4:2:2	YCrCb[7:0]	Three-State
0110-1111	Reserved.	Reserved. Do not use.	

MPU PORT DESCRIPTION

The ADV7181 supports a 2-wire (I²C-compatible) serial interface. Two inputs, serial data SDA and serial clock SCLK, carry information between the ADV7181 and the system I²C master controller. Each slave device is recognized by a unique address. The ADV7181's I²C port allows the user to set up and configure the decoder and to read back captured VBI data. The ADV7181 has four possible slave addresses for both read and write operations, depending on the logic level on the ALSB pin. These four unique addresses are shown in Table 168. The ADV7181's ALSB pin controls Bit 1 of the slave address. By altering the ALSB, it is possible to control two ADV7181s in an application without having a conflict with the same slave address. The LSB (Bit 0) sets either a read or write operation. Logic 1 corresponds to a read operation; Logic 0 corresponds to a write operation.

Table 168. I²C Address for ADV7181

ALSB	R/W	Slave Address
0	0	0x40
0	1	0x41
1	0	0x42
1	1	0x43

To control the device on the bus, a specific protocol must be followed. First, the master initiates a data transfer by establishing a start condition, which is defined by a high-to-low transition on SDA while SCLK remains high. This indicates that an address/data stream follows. All peripherals respond to the start condition and shift the next eight bits (7-bit address + R/W bit). The bits are transferred from MSB down to LSB. The peripheral that recognizes the transmitted address responds by pulling the data line low during the ninth clock pulse; this is known as an acknowledge bit. All other devices withdraw from the bus at this point and maintain an idle condition. The idle condition is where the device monitors the SDA and SCLK lines, waiting for the start condition and the correct transmitted address. The R/W bit determines the direction of the data. Logic 0 on the

LSB of the first byte means that the master writes information to the peripheral. Logic 1 on the LSB of the first byte means that the master reads information from the peripheral.

The ADV7181 acts as a standard slave device on the bus. The data on the SDA pin is eight bits long, supporting the 7-bit addresses plus the R/W bit. The ADV7181 has 196 subaddresses to enable access to the internal registers. It therefore interprets the first byte as the device address and the second byte as the starting subaddress. The subaddresses auto-increment, allowing data to be written to or read from the starting subaddress. A data transfer is always terminated by a stop condition. The user can also access any unique subaddress register on a one-by-one basis without updating all the registers.

Stop and start conditions can be detected at any stage during the data transfer. If these conditions are asserted out of sequence with normal read and write operations, they cause an immediate jump to the idle condition. During a given SCLK high period, the user should issue only one start condition, one stop condition, or a single stop condition followed by a single start condition. If an invalid subaddress is issued by the user, the ADV7181 does not issue an acknowledge and returns to the idle condition.

If in auto-increment mode the user exceeds the highest subaddress, the following action is taken:

1. In read mode, the highest subaddress register contents continue to be output until the master device issues a no-acknowledge. This indicates the end of a read. A no-acknowledge condition is when the SDA line is not pulled low on the ninth pulse.
2. In write mode, the data for the invalid byte is not loaded into any subaddress register, a no acknowledge is issued by the ADV7181, and the part returns to the idle condition.

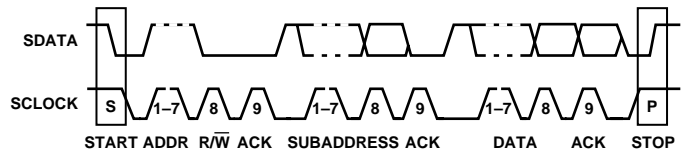

Figure 35. Bus Data Transfer

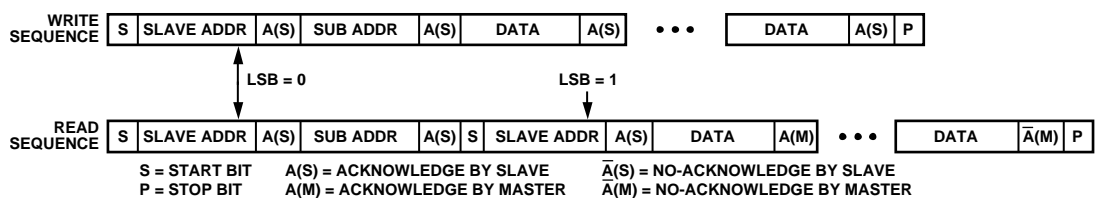

Figure 36. Read and Write Sequence

REGISTER ACCESSES

The MPU can write to or read from all of the ADV7181's registers, except those registers that are read-only or write-only. The Subaddress register determines which register the next read or write operation accesses. All communications with the part through the bus start with an access to the Subaddress register. Then a read/write operation is performed from/to the target address, which increments to the next address until a stop command on the bus is performed.

REGISTER PROGRAMMING

The following sections describe each register in terms of its configuration. The Communications register is an 8-bit, write-only register. After the part has been accessed over the bus and a read/write operation is selected, the subaddress is set up. The Subaddress register determines to/from which register the operation takes place. Table 170 lists the various operations under the control of the Subaddress register for the control port.

Register Select (SR7-SR0)

These bits are set up to point to the required starting address.

I²C SEQUENCER

An I²C sequencer is used when a parameter exceeds eight bits, and is therefore distributed over two or more I²C registers, for example, HSB [11:0].

When such a parameter is changed using two or more I²C write operations, the parameter may hold an invalid value for the time between the first I²C finishing and the last I²C being completed. In other words, the top bits of the parameter may already hold the new value while the remaining bits of the parameter still hold the previous value.

To avoid this problem, the I²C sequencer holds the already updated bits of the parameter in local memory; all bits of the parameter are updated together once the last register write operation has completed.

The correct operation of the I²C sequencer relies on the following:

- All I²C registers for the parameter in question must be written to in order of ascending addresses, for example, for HSB[10:0], write to Address 0x34 first, followed by 0x35.
- No other I²C taking place between the two (or more) I²C writes for the sequence, for example, for HSB[10:0], write to Address 0x34 first, immediately followed by 0x35.

I²C CONTROL REGISTER MAP

Table 169. Control Port Register Map Details

Register Name	Reset Value	rw	Subaddress	
			Dec	Hex
Input Control	0000 0000	rw	0	00
Video Selection	1100 1000	rw	1	01
Reserved	0000 0100	rw	2	02
Output Control	0000 1100	rw	3	03
Extended Output Control	0101 0101	rw	4	04
Reserved	0000 0000	rw	5	05
Reserved	0000 0010	rw	6	06
Autodetect Enable	0111 1111	rw	7	07
Contrast	1000 0000	rw	8	08
Reserved	1000 0000	rw	9	09
Brightness	0000 0000	rw	10	0A
Hue	0000 0000	rw	11	0B
Default Value Y	0011 0110	rw	12	0C
Default Value C	0111 1100	rw	13	0D
ADI Control	0000 0101	rw	14	0E
Power Management	0000 0000	rw	15	0F
Status 1	xxxx xxxx	r	16	10
Ident	xxxx xxxx	r	17	11
Status 2	xxxx xxxx	r	18	12
Status 3	xxxx xxxx	r	19	13
Analog Clamp Control	0001 0010	rw	20	14
Digital Clamp Control 1	0100 xxxx	rw	21	15
Reserved	xxxx xxxx	rw	22	16
Shaping Filter Control	0000 0001	rw	23	17
Shaping Filter Control 2	1001 0011	rw	24	18
Comb Filter Control	1111 0001	rw	25	19
Reserved	xxxx xxxx	rw	26–38	1A–26
Pixel Delay Control	0101 1000	rw	39	27
Reserved	xxxx xxxx	rw	40	28–2A
Misc Gain Control	1110 0011	rw	43	2B
AGC Mode Control	1010 1110	rw	44	2C
Chroma Gain Control 1	1111 0100	rw	45	2D
Chroma Gain Control 2	0000 0000	rw	46	2E
Luma Gain Control 1	1111 xxxx	rw	47	2F
Luma Gain Control 2	xxxx xxxx	rw	48	30
VSyn Field Control 1	0001 0010	rw	49	31
VSyn Field Control 2	0100 0001	rw	50	32
VSyn Field Control 3	1000 0100		51	33
HSyn Position Control 1	0000 0000	rw	52	34
HSyn Position Control 2	0000 0010	rw	53	35
HSyn Position Control 3	0000 0000	rw	54	36
Polarity	0000 0001	rw	55	37
NTSC Comb Control	1000 0000	rw	56	38
PAL Comb Control	1100 0000	rw	57	39
ADC Control	0001 0000	rw	58	3A
Reserved	xxxx xxxx	rw	59–60	3B–3C
Manual Window Control	0100 0011	rw	61	3D
Reserved	0101 0000	rw	62–70	3E–47
Gemstar Ctrl 1	00000000	rw	72	48
Gemstar Ctrl 2	0000 0000	rw	73	49

Register Name	Reset Value	rw	Subaddress	
			Dec	Hex
Gemstar Ctrl 3	0000 0000	rw	74	4A
Gemstar Ctrl 4	0000 0000	rw	75	4B
GemStar Ctrl 5	xxxx xxxx0	rw	76	4C
CTI DNR Ctrl 1	1110 1111	rw	77	4D
CTI DNR Ctrl 2	0000 1000	rw	78	4E
Reserved	xxxx xxxx	rw	79	4F
CTI DNR Ctrl 4	0000 1000	rw	80	50
Lock Count	1010 0100	rw	81	51
Reserved	xxxx xxxx	rw	82–142	52–8E
Free Run Line Length 1	0000 0000	w	143	8F
Reserved	0000 0000	w	144	90
VBI Info	xxxx xxxx	r	144	90
WSS 1	xxxx xxxx	r	145	91
WSS 2	xxxx xxxx	r	146	92
EDTV 1	xxxx xxxx	r	147	93
EDTV 2	xxxx xxxx	r	148	94
EDTV 3	xxxx xxxx	r	149	95
CGMS 1	xxxx xxxx	r	150	96
CGMS 2	xxxx xxxx	r	151	97
CGMS 3	xxxx xxxx	r	152	98
CCAP 1	xxxx xxxx	r	153	99
CCAP 2	xxxx xxxx	r	154	9A
Letterbox 1	xxxx xxxx	r	155	9B
Letterbox 2	xxxx xxxx	r	156	9C
Letterbox 3	xxxx xxxx	r	157	9D
Reserved	xxxx xxxx	rw	158-177	9E–B1
CRC Enable	0001 1100	w	178	B2
Reserved	xxxx xxxx	rw	179–194	B2–C2
ADC Switch 1	xxxx xxxx	rw	195	C3
ADC Switch 2	0xxx xxxx	rw	196	C4
Reserved	xxxx xxxx	rw	197–219	C5–DB
Letterbox Control 1	1010 1100	rw	220	DC
Letterbox Control 2	0100 1100	rw	221	DD
Reserved	0000 0000	rw	222	DE
Reserved	0000 0000	rw	223	DF
Reserved	0001 0100	rw	224	E0
SD Offset Cb	1000 0000	rw	225	E1
SD Offset Cr	1000 0000	rw	226	E2
SD Saturation Cb	1000 0000	rw	227	E3
SD Saturation Cr	1000 0000	rw	228	E4
NTSC V Bit Begin	0010 0101	rw	225	E5
NTSC V Bit End	0000 0100	rw	226	E6
NTSC F Bit Toggle	0110 0011	rw	227	E7
PAL V Bit Begin	0110 0101	rw	225	E8
PAL V Bit End	0001 0100	rw	226	E9
PAL F Bit Toggle	0110 0011	rw	227	EA

Table 170. Control Port Register Map Bit Details

Register Name	Bit 7	Bit 6	Bit 5	Bit 4	Bit 3	Bit 2	Bit 1	Bit 0
Input Control	VID_SEL.3	VID_SEL.2	VID_SEL.1	VID_SEL.0	INSEL.3	INSEL.2	INSEL.1	INSEL.0
Video Selection		ENHSPLL	BETACAM		ENVSPROC			
Reserved								
Output Control	VBI_EN	TOD	OF_SEL.3	OF_SEL.2	OF_SEL.1	OF_SEL.0		SD_DUP_AV
Extended Output Control	BT656-4		DR_STR.1	DR_STR.0	TIM_OE	BL_C_VBI	EN_SFL_PI	RANGE
Reserved								
Reserved								
Autodetect Enable	AD_SEC525_EN	AD_SECAM_EN	AD_N443_EN	AD_P60_EN	AD_PALN_EN	AD_PALM_EN	AD_NTSC_EN	AD_PAL_EN
Contrast	CON.7	CON.6	CON.5	CON.4	CON.3	CON.2	CON.1	CON.0
Reserved								
Brightness	BRI.7	BRI.6	BRI.5	BRI.4	BRI.3	BRI.2	BRI.1	BRI.0
Hue	HUE.7	HUE.6	HUE.5	HUE.4	HUE.3	HUE.2	HUE.1	HUE.0
Default Value Y	DEF_Y.5	DEF_Y.4	DEF_Y.3	DEF_Y.2	DEF_Y.1	DEF_Y.0	DEF_VAL_AUTO_EN	DEF_VAL_EN
Default Value C	DEF_C.7	DEF_C.6	DEF_C.5	DEF_C.4	DEF_C.3	DEF_C.2	DEF_C.1	DEF_C.0
ADI Control		TRI_LLC			DR_STR_C.1	DR_STR_C.0	DR_STR_S.1	DR_STR_S.0
Power Management			PWRDN			PDBP		
Status 1	COL_KILL	AD_RESULT.2	AD_RESULT.1	AD_RESULT.0	FOLLOW_PW	FSC_LOCK	LOST_LOCK	IN_LOCK
Ident	IDENT.7	IDENT.6	IDENT.5	IDENT.4	IDENT.3	IDENT.2	IDENT.1	IDENT.0
Status 2			FSC_NSTD	LL_NSTD	MV_AGC_DET	MV_PS_DET	MVCS_T3	MVCS_DET
Status 3	PAL_SW_LOCK	INTERLACE	STD_FLD_LEN	FREE_RUN_ACT				INST_HLOCK
Analog Clamp Control				CCLEN				
Digital Clamp Control 1		DCT.1	DCT.0					
Reserved								
Shaping Filter Control	CSFM.2	CSFM.1	CSFM.0	YSFM.4	YSFM.3	YSFM.2	YSFM.1	YSFM.0
Shaping Filter Control 2	WYSFMOVR			WYSFM.4	WYSFM.3	WYSFM.2	WYSFM.1	WYSFM.0
Comb Filter Control					NSFSEL.1	NSFSEL.0	PSFSEL.1	PSFSEL.0
Reserved								
Pixel Delay Control	SWPC	AUTO_PDC_EN	CTA.2	CTA.1	CTA.0		LTA.1	LTA.0
Reserved								
Misc Gain Control		CKE						PW_UPD
AGC Mode Control		LAGC.2	LAGC.1	LAGC.0			CAGC.1	CAGC.0
Chroma Gain Control 1	CAGT.1	CAGT.0			CMG.11	CMG.10	CMG.9	CMG.8
Chroma Gain Control 2	CMG.7	CMG.6	CMG.5	CMG.4	CMG.3	CMG.2	CMG.1	CMG.0
Luma Gain Control 1	LAGT.1	LGAT.0			LMG.11	LMG.10	LMG.9	LMG.8
Luma Gain Control 2	LMG.7	LMG.6	LMG.5	LMG.4	LMG.3	LMG.2	LMG.1	LMG.0
VSync Field Control 1				NEWAVMODE	HVSTIM			
VSync Field Control 2	VSBHO	VSBHE						
VSync Field Control 3	VSEHO	VSEHE						
HSync Position Control 1		HSB.10	HSB.9	HSB.8		HSE.10	HSE.9	HSE.8
HSync Position Control 2	HSB.7	HSB.6	HSB.5	HSB.4	HSB.3	HSB.2	HSB.1	HSB.0
HSync Position Control 3	HSE.7	HSE.6	HSE.5	HSE.4	HSE.3	HSE.2	HSE.1	HSE.0
Polarity	PHS		PVS		PF			PCLK
NTSC Comb Control	CTAPSN.1	CTAPSN.0	CCMN.2	CCMN.1	CCMN.0	YCMN.2	YCMN.1	YCMN.0
PAL Comb Control	CTAPSP.1	CTAPSP.0	CCMP.2	CCMP.1	CCMP.0	YCMP.2	YCMP.1	YCMP.0
ADC Control					PWRDN_AD_C_0	PWRDN_AD_C_1	PWRDN_ADC_2	
Reserved								
Manual Window Control		CKILLTHR.2	CKILLTHR.1	CKILLTHR.0				
Reserved								

ADV7181

Register Name	Bit 7	Bit 6	Bit 5	Bit 4	Bit 3	Bit 2	Bit 1	Bit 0
Gemstar Ctrl 1	GDECEL.15	GDECEL.14	GDECEL.13	GDECEL.12	GDECEL.11	GDECEL.10	GDECEL.9	GDECEL.8
Gemstar Ctrl 2	GDECEL.7	GDECEL.6	GDECEL.5	GDECEL.4	GDECEL.3	GDECEL.2	GDECEL.1	GDECEL.0
Gemstar Ctrl 3	GDECOL.15	GDECOL.14	GDECOL.13	GDECOL.12	GDECOL.11	GDECOL.10	GDECOL.9	GDECOL.8
Gemstar Ctrl 4	GDECOL.7	GDECOL.6	GDECOL.5	GDECOL.4	GDECOL.3	GDECOL.2	GDECOL.1	GDECOL.0
Gemstar Ctrl 5								GDECAD
CTI DNR Ctrl 1			DNR_EN		CTI_AB.1	CTI_AB.0	CTI_AB_EN	CTI_EN
CTI DNR Ctrl 2	CTI_C_TH.7	CTI_C_TH.6	CTI_C_TH.5	CTI_C_TH.4	CTI_C_TH.3	CTI_C_TH.2	CTI_C_TH.1	CTI_C_TH.0
Reserved								
CTI DNR Ctrl 4	DNR_TH.7	DNR_TH.6	DNR_TH.5	DNR_TH.4	DNR_TH.3	DNR_TH.2	DNR_TH.1	DNR_TH.0
Lock Count	FSCLE	SRLS	COL.2	COL.1	COL.0	CIL.2	CIL.1	CIL.0
Reserved								
Free Run Line Length 1		LLC_PAD_SEL.2	LLC_PAD_SEL.1	LLC_PAD_SEL.0				
Reserved								
VBI Info					CGMSD	EDTVD	CCAPD	WSSD
WSS 1	WSS1.7	WSS1.6	WSS1.5	WSS1.4	WSS1.3	WSS1.2	WSS1.1	WSS1.0
WSS 2	WSS2.7	WSS2.6	WSS2.5	WSS2.4	WSS2.3	WSS2.2	WSS2.1	WSS2.0
EDTV 1	EDTV1.7	EDTV1.6	EDTV1.5	EDTV1.4	EDTV1.3	EDTV1.2	EDTV1.1	EDTV1.0
EDTV 2	EDTV2.7	EDTV2.6	EDTV2.5	EDTV2.4	EDTV2.3	EDTV2.2	EDTV2.1	EDTV2.0
EDTV 3	EDTV3.7	EDTV3.6	EDTV3.5	EDTV3.4	EDTV3.3	EDTV3.2	EDTV3.1	EDTV3.0
CGMS 1	CGMS1.7	CGMS1.6	CGMS1.5	CGMS1.4	CGMS1.3	CGMS1.2	CGMS1.1	CGMS1.0
CGMS 2	CGMS2.7	CGMS2.6	CGMS2.5	CGMS2.4	CGMS2.3	CGMS2.2	CGMS2.1	CGMS2.0
CGMS 3	CGMS3.7	CGMS3.6	CGMS3.5	CGMS3.4	CGMS3.3	CGMS3.2	CGMS3.1	CGMS3.0
CCAP 1	CCAP1.7	CCAP1.6	CCAP1.5	CCAP1.4	CCAP1.3	CCAP1.2	CCAP1.1	CCAP1.0
CCAP 2	CCAP2.7	CCAP2.6	CCAP2.5	CCAP2.4	CCAP2.3	CCAP2.2	CCAP2.1	CCAP2.0
Letterbox 1	LB_LCT.7	LB_LCT.6	LB_LCT.5	LB_LCT.4	LB_LCT.3	LB_LCT.2	LB_LCT.1	LB_LCT.0
Letterbox 2	LB_LCM.7	LB_LCM.6	LB_LCM.5	LB_LCM.4	LB_LCM.3	LB_LCM.2	LB_LCM.1	LB_LCM.0
Letterbox 3	LB_LCB.7	LB_LCB.6	LB_LCB.5	LB_LCB.4	LB_LCB.3	LB_LCB.2	LB_LCB.1	LB_LCB.0
Reserved								
CRC Enable						CRC_ENABLE		
Reserved								
ADC Switch 1	ADC1_SW.3	ADC1_SW.2	ADC1_SW.1	ADC1_SW.0	ADC0_SW.3	ADC0_SW.2	ADC0_SW.1	ADC0_SW.0
ADC Switch 2	ADC_SW_M AN				ADC2_SW.3	ADC2_SW.2	ADC2_SW.1	ADC2_SW.0
Reserved								
Letterbox Control 1				LB_TH.4	LB_TH.3	LB_TH.2	LB_TH.1	LB_TH.0
Letterbox Control 2	LB_SL.3	LB_SL.2	LB_SL.1	LB_SL.0	LB_EL.3	LB_EL.2	LB_EL.1	LB_EL.0
Reserved								
Reserved								
Reserved								
SD Offset Cb	SD_OFF_CB.7	SD_OFF_CB.6	SD_OFF_CB.5	SD_OFF_CB.4	SD_OFF_CB.3	SD_OFF_CB.2	SD_OFF_CB.1	SD_OFF_CB.0
SD Offset Cr	SD_OFF_CR.7	SD_OFF_CR.6	SD_OFF_CR.5	SD_OFF_CR.4	SD_OFF_CR.3	SD_OFF_CR.2	SD_OFF_CR.1	SD_OFF_CR.0
SD Saturation Cb	SD_SAT_CB.7	SD_SAT_CB.6	SD_SAT_CB.5	SD_SAT_CB.4	SD_SAT_CB.3	SD_SAT_CB.2	SD_SAT_CB.1	SD_SAT_CB.0
SD Saturation Cr	SD_SAT_CR.7	SD_SAT_CR.6	SD_SAT_CR.5	SD_SAT_CR.4	SD_SAT_CR.3	SD_SAT_CR.2	SD_SAT_CR.1	SD_SAT_CR.0
NTSC V Bit Begin	NVBEGDEL O	NVBEGDEL E	NVBEGSIGN	NVBEG.4	NVBEG.3	NVBEG.2	NVBEG.1	NVBEG.0
NTSC V Bit End	NVENDDEL O	NVENDDEL E	NVENDSIGN	NVEND.4	NVEND.3	NVEND.2	NVEND.1	NVEND.0
NTSC F Bit Toggle	NFTOGDEL O	NFTOGDEL E	NFTOGSIGN	NFTOG.4	NFTOG.3	NFTOG.2	NFTOG.1	NFTOG.0
PAL V Bit Begin	PVBEGDEL O	PVBEGDEL E	PVBEGSIGN	PVBEG.4	PVBEG.3	PVBEG.2	PVBEG.1	PVBEG.0
PAL V Bit End	PVENDDEL O	PVENDDEL E	PVENDSIGN	PVEND.4	PVEND.3	PVEND.2	PVEND.1	PVEND.0
PAL F Bit Toggle	PFTOGDEL O	PFTOGDEL E	PFTOGSIGN	PFTOG.4	PFTOG.3	PFTOG.2	PFTOG.1	PFTOG.0

I²C REGISTER MAP DETAILS

Grayed out sections mark the reset value of the register.

Table 171. Register 0x00

Subaddress	Register	Bit Description	Bit								Register Setting	
			7	6	5	4	3	2	1	0		
0x00	Input Control	INSEL [3:0] . The INSEL bits must be set to correctly configure the ADV7181 to process the input video format.										
							0	0	0	0	Composite	
							0	1	1	0	S-Video	
						1	0	0	1	YPrPb		
		VID_SEL [3:0] . The VID_SEL bits allow the user to select the input video standard.	0	0	0	0					Autodetect PAL (BGHID), NTSC (without pedestal), SECAM	
			0	0	0	1					Autodetect PAL (BGHID), NTSC (M) (with pedestal), SECAM	
			0	0	1	0					Autodetect PAL (N), NTSC (M) (without pedestal), SECAM	
			0	0	1	1					Autodetect PAL (N), NTSC (M) (with pedestal), SECAM	
			0	1	0	0					NTSC(J)	
			0	1	0	1					NTSC(M)	
			0	1	1	0					PAL 60	
			0	1	1	1					NTSC 4.43	
			1	0	0	0					PAL BGHID	
			1	0	0	1					PAL N (BGHID without pedestal)	
			1	0	1	0					PAL M (without pedestal)	
			1	0	1	1					PAL M	
			1	1	0	0					PAL combination N	
1	1		0	1					PAL combination N (with pedestal)			
1	1	1	0					SECAM				
1	1	1	1					SECAM (with pedestal)				

Table 172. Register 0x01

Subaddress	Register	Bit Description	Bit								Register Setting	Comments
			7	6	5	4	3	2	1	0		
0x01	Video Selection	Reserved.										
								0	0	0	Set to default	
		ENVSPROC					0				Disable VSync processor	
						1					Enable VSync processor	
		Reserved.										
						0					Set to default	
		BETACAM			0						Standard video input	
					1						Betacam input enable	
		ENHSPLL										
					0						Disable HSync processor	
					1						Enable HSync processor	
Reserved.												
			1						Set to default			

ADV7181

Table 173. Register 0x03

Subaddress	Register	Bit Description	Bit								Register Setting	Comments	
			7	6	5	4	3	2	1	0			
0x03	Output Control	SD_DUP_AV. Duplicates the AV codes from the Luma into the chroma path.									0	AV codes to suit 8-bit interleaved data output	
											1	AV codes duplicated (for 16-bit interfaces)	
		Reserved.								0	Set as default		
		OF_SEL [3:0]. Allows the user to choose from a set of output formats.										Reserved	
					0	0	0	0				Reserved	
					0	0	0	1				16-bit @ LLC1 4:2:2	
					0	0	1	1				8-bit @ LLC1 4:2:2 ITU-R BT.656	
					0	1	0	0				Not used	
					0	1	0	1				Not used	
					0	1	1	0				Not used	
					0	1	1	1				Not used	
					1	0	0	0				Not used	
					1	0	0	1				Not used	
					1	0	1	0				Not used	
					1	0	1	1				Not used	
					1	1	0	0				Not used	
					1	1	0	1				Not used	
					1	1	1	0				Not used	
					1	1	1	1				Not used	
		TOD. Three-State Output Drivers. This bit allows the user to three-state the output drivers: P[19:0], HS, VS, FIELD, and SFL.										See also TIM_OE (Table 174); TRI_LLC (Table 176)	
			0	Output pins enabled									
			1	Drivers three-stated									
		VBI_EN. Allows VBI data (Lines 1 to 21) to be passed through with only a minimum amount of filtering performed.	0	All lines filtered and scaled									
			1	Only active video region filtered									

Table 174. Register 0x04

Subaddress	Register	Bit Description	Bit								Register Setting	Comments			
			7	6	5	4	3	2	1	0					
0x04	Extended Output Control	RANGE. Allows the user to select the range of output values. Can be BT656 compliant, or can fill the whole accessible number range.													
												0	16 < Y < 235, 16 < C < 240	ITU-R BT.656	
												1	1 < Y < 254, 1 < C < 254	Extended range	
		EN_SFL_PIN.										0	SFL output is disabled	SFL output enables encoder and decoder to be connected directly	
												1	SFL information output on the SFL pin		
		BL_C_VBI. Blank Chroma during VBI. If set, enables data in the VBI region to be passed through the decoder undistorted.										0	Decode and output color	During VBI	
												1	Blank Cr and Cb		
		TIM_OE. Timing signals output enable.										0	HS, VS, F three-stated	Controlled by TOD	
												1	HS, VS, F forced active		
		DR_STR[1:0]. Drive strength of output drivers can be increased or decreased for EMC or crosstalk reasons.				0	0						Low drive, 1x	Recommended	
						0	1						Medium-low, 2x		
						1	0						Medium-high, 3x		
						1	1						High drive, 4x		
		Reserved.													
												1	Set to default		
BT656-4. Allows the user to select an output mode compatible with ITU- R BT656-3/4.										0	BT656-3-compatible				
										1	BT656-4-compatible				

ADV7181

Table 175. Registers 0x07 and 0x08

Subaddress	Register	Bit Description	Bit								Register Setting	Comments				
			7	6	5	4	3	2	1	0						
0x07	Autodetect Enable	AD_PAL_EN. PAL B/G/I/H autodetect enable.									0	Disable				
											1	Enable				
		AD_NTSC_EN. NTSC autodetect enable.									0	Disable				
											1	Enable				
		AD_PALM_EN. PAL M autodetect enable									0	Disable				
											1	Enable				
		AD_PALN_EN. PAL N autodetect enable.									0	Disable				
											1	Enable				
		AD_P60_EN. PAL 60 autodetect enable.					0					Disable				
							1					Enable				
		AD_N443_EN. NTSC443 autodetect enable.				0						Disable				
						1						Enable				
		AD_SECAM_EN. SECAM autodetect enable.									0	Disable				
											1	Enable				
		AD_SEC525_EN. SECAM 525 autodetect enable.									0	Disable				
											1	Enable				
		0x08	Contrast	CON[7:0]. Contrast adjust. This is the user control for contrast adjustment.											Luma gain = 1	0x00 gain = 0 0x80 gain = 1 0xFF gain = 2
					1	0	0	0	0	0	0	0				

Table 176. Registers 0x09 to 0x0E

Subaddress	Register	Bit Description	Bit								Register Setting	Comments			
			7	6	5	4	3	2	1	0					
0x09	Reserved. (Saturation)	Reserved.	1	0	0	0	0	0	0	0					
0x0A	Brightness	BRI[7:0] . This register controls the brightness of the video signal.	0	0	0	0	0	0	0	0		0x00 = 0IRE 0x7F = 100IRE 0x80 = -100IRE			
0x0B	Hue	HUE[7:0] . This register contains the value for the color hue adjustment.	0	0	0	0	0	0	0	0		Hue range = -90° to +90°			
0x0C	Default Value Y	DEF_VAL_EN . Default value enable.								0	Free Run mode dependent on DEF_VAL_AUTO_EN				
										1	Force Free Run mode on and output blue screen				
		DEF_VAL_AUTO_EN . Default value.							0	Disable Free Run mode	When lock is lost, Free Run mode can be enabled to output stable timing, clock, and a set color.				
									1	Enable Automatic Free Run mode (blue screen)					
		DEF_Y[5:0] . Default value Y. This register holds the Y default value.	0	0	1	1	0	1					Y[7:0] = {DEF_Y[5:0], 0, 0, 0, 0}	Default Y value output in free-run mode.	
0x0D	Default Value C	DEF_C[7:0] . Default value C. Cr and Cb default values are defined in this register.	0	1	1	1	1	1	0	0	Cr[7:0] = {DEF_C[7:4], 0, 0, 0, 0, 0, 0} Cb[7:0] = {DEF_C[3:0], 0, 0, 0, 0, 0, 0}	Default Cb/Cr value output in Free Run mode. Default values give blue screen output.			
0x0E	ADI Control	DR_STR_S[1:0] . Select the drive strength of the sync signals. HS, VS, and F can be increased or decreased for EMC or crosstalk reasons.								0	0	Low drive strength (1x)			
											0	1		Medium-low (2x)	
												1		0	Medium-high (3x)
												1		1	High drive strength (4x)
		DR_STR_C[1:0] . Select the strength of the clock signal output driver. Can be increased or decreased for EMC or crosstalk reasons.								0	0			Low drive strength (1x)	
										0	1			Medium-low (2x)	
										1	0			Medium-high (3x)	
										1	1			High drive strength (4x)	
		Reserved.				0	0								See TOD (Table 173); TIM_OE (Table 174)
		TRI_LLC . Enables the LLC pin to be three-stated.												Set as default	
				0										LLC pin active	
				1										LLC pin drivers three-stated	
		Reserved.												Set as default	

ADV7181

Table 177. Registers 0x0F to 0x11

Subaddress	Register	Bit Description	Bit							Register Setting	Comments			
			7	6	5	4	3	2	1			0		
0x0F	Power Management	Reserved.												
									0	0	Set to default			
		PDBP. Power-down bit priority selects between PWRDN bit or PIN.						0		Chip power-down controlled by pin				
								1		Bit has priority (pin disregarded)				
		Reserved.												
					0	0				Set to default				
		PWRDN. Power-down places the decoder in a full power-down mode.		0						System functional	See PDBP, 0x0F, Bit 2			
				1						Powered down				
		Reserved.												
				0						Set to default				
		RES. ChprReset loads all I ² C bits with default values.	0							Normal operation	Executing reset takes approx. 2 ms. This bit is self clearing.			
			1							Start reset sequence				
0x10	Status. Read-only	STATUS_1[7:0]. Provides information about the internal status of the decoder.												
		STATUS_1[3:0].								x	In lock (right now) = 1			
										x	Lost lock (since last read)			
									x		Fsc lock (right now) = 1			
							x				Peak white AGC mode active = 1			
		STATUS_1[6:4]												
		AD_RESULT[2:0]. Autodetection result reports the findings.		0	0	0				NTSM-MJ	Detected standard			
				0	0	1				NTSC-443				
				0	1	0				PAL-M				
				0	1	1				PAL-60				
		1	0	0				PAL-BGHID						
		1	0	1				SECAM						
		1	1	0				PAL combination N						
		1	1	1				SECAM 525						
STATUS_1[7]														
COL_KILL. Color Kill.		x							Color kill is active = 1					
0x11	Info. Read-only	IDENT[7:0] Provides identification on the revision of the part.	x	x	x	x	x	x	x					

Table 178. Registers 0x12 and 0x13

Subaddress	Register	Bit Description	Bit								Register Setting	Comments		
			7	6	5	4	3	2	1	0				
0x12	Status Register 2. Read-only.	STATUS_2[7:0] . Provides information about the internal status of the decoder.												
		STATUS_2[5:0].									x	MV color striping detected	1 = Detected	
											x	MV color striping type	0 = Type 2, 1 = Type 3	
										x		MV pseudosync detected	1 = Detected	
								x				MV AGC pulses detected	1 = Detected	
									x			Nonstandard line length	1 = Detected	
										x		Fsc frequency nonstandard	1 = Detected	
				Reserved.										
0x13	Status Register 3. Read-only.	STATUS_3[7:0] . Provides information about the internal status of the decoder.	x	x										
											x	1 = Horizontal lock achieved	Unfiltered	
									x	x	x		1 = Reserved bits	No function
												x	1 = Free Run mode active	Blue screen output
												x	1 = Field length standard	
												x	1 = Swinging burst detected	Reliable sequence

Table 179. Register 0x14

Subaddress	Register	Bit Description	Bit								Register Setting			
			7	6	5	4	3	2	1	0				
0x14	Analog Clamp Control	Reserved.												
								0	0	1	0	Reserved. Set to default.		
		CLEN . Current clamp enable allows the user to switch off the current sources in the analog front.						0						1 sources switched off.
								1						1 sources enabled.
		Reserved.						0						Reserved. Set to default.
		Reserved.												
						0	0						Reserved. Set to default.	

Table 180. Register 0x15

Subaddress	Register	Bit Description	Bit								Register Setting			
			7	6	5	4	3	2	1	0				
0x15	Digital Clamp Control 1	Reserved.												
								x	x	x	x	x	Set to default	
		DCT[1:0] . Digital clamp timing determines the time constant of the digital fine clamp circuitry.												
								0	0					Slow (TC = 1 s)
								0	1					Medium (TC = 0.5 s)
								1	0					Fast (TC = 0.1 s)
						1	1					TC dependent on video		
		Reserved.												
			0									Set to default		

Table 181. Register 0x17

Subaddress	Register	Bit Description	Bit								Register Setting	Comments
			7	6	5	4	3	2	1	0		
0x17	Shaping Filter Control	YSFM[4:0] . Selects Y Shaping Filter mode when in CVBS only mode. Allows the user to select a wide range of low-pass and notch filters. If either auto mode is selected, the decoder selects the optimum Y filter depending on the CVBS video source quality (good vs. bad).				0	0	0	0	0	Auto wide notch for poor quality sources or wide-band filter with Comb for good quality input.	Decoder selects optimum Y shaping filter depending on CVBS quality.
						0	0	0	0	1	Auto narrow notch for poor quality sources or wideband filter with comb for good quality input.	
						0	0	0	1	0	SVHS 1	If one of these modes is selected, the decoder does not change filter modes depending on video quality. A fixed filter response (the one selected) is used for good and bad quality video.
						0	0	0	1	1	SVHS 2	
						0	0	1	0	0	SVHS 3	
						0	0	1	0	1	SVHS 4	
						0	0	1	1	0	SVHS 5	
						0	0	1	1	1	SVHS 6	
						0	1	0	0	0	SVHS 7	
						0	1	0	0	1	SVHS 8	
						0	1	0	1	0	SVHS 9	
						0	1	0	1	1	SVHS 10	
						0	1	1	0	0	SVHS 11	
						0	1	1	0	1	SVHS 12	
						0	1	1	1	0	SVHS 13	
						0	1	1	1	1	SVHS 14	
						1	0	0	0	0	SVHS 15	
						1	0	0	0	1	SVHS 16	
						1	0	0	1	0	SVHS 17	
						1	0	0	1	1	SVHS 18 (CCIR601)	
					1	0	1	0	0	PAL NN1		
					1	0	1	0	1	PAL NN2		
					1	0	1	1	0	PAL NN3		
					1	0	1	1	1	PAL WN 1		
					1	1	0	0	0	PAL WN 2		
					1	1	0	0	1	NTSC NN1		
					1	1	0	1	0	NTSC NN2		
					1	1	0	1	1	NTSC NN3		
					1	1	1	0	0	NTSC WN1		
					1	1	1	0	1	NTSC WN2		
			1	1	1	1	0	NTSC WN3				
			1	1	1	1	1	Reserved				
		CSFM[2:0] . C Shaping Filter mode allows the selection from a range of low-pass chrominance filters. If either auto mode is selected, the decoder selects the optimum C filter depending on the CVBS video source quality (good vs. bad). Non-auto settings force a C filter for all standards and quality of CVBS video.	0	0	0					Auto selection 1.5 MHz	Automatically selects a C filter based on video standard and quality.	
			0	0	1							Auto selection 2.17 MHz
			0	1	0							SH1
			0	1	1							SH2
			1	0	0							SH3
			1	0	1							SH4
			1	1	0							SH5
		1	1	1						Wideband mode		

Table 182. Register 0x18 to 0x19

Subaddress	Register	Bit Description	Bit								Comments
			7	6	5	4	3	2	1	0	
0x18	Shaping Filter Control 2	WYSFM[4:0] Wideband Y Shaping Filter mode allows the user to select which Y shaping filter is used for the Y component of Y/C, YPbPr, B/W input signals; it is also used when a good quality input CVBS signal is detected. For all other inputs, the Y shaping filter chosen is controlled by YFSM[4:0].				0	0	0	0	0	Reserved. Do not use.
						0	0	0	0	1	Reserved. Do not use.
						0	0	0	1	0	SVHS 1
						0	0	0	1	1	SVHS 2
						0	0	1	0	0	SVHS 3
						0	0	1	0	1	SVHS 4
						0	0	1	1	0	SVHS 5
						0	0	1	1	1	SVHS 6
						0	1	0	0	0	SVHS 7
						0	1	0	0	1	SVHS 8
						0	1	0	1	0	SVHS 9
						0	1	0	1	1	SVHS 10
						0	1	1	0	0	SVHS 11
						0	1	1	0	1	SVHS 12
						0	1	1	1	0	SVHS 13
						0	1	1	1	1	SVHS 14
						1	0	0	0	0	SVHS 15
						1	0	0	0	1	SVHS 16
						1	0	0	1	0	SVHS 17
						1	0	0	1	1	SVHS 18 (CCIR 601)
			1	0	1	0	0	Reserved. Do not use.			
								Reserved. Do not use.			
			1	1	1	1	1	Reserved. Do not use.			
		Reserved.									
			0	0					Set to default		
		WYSFMOVR. Enables the use of the automatic WYSFN filter.	0						Auto selection of best filter		
			1						Manual select filter using WYSFM[4:0]		
0x19	Comb Filter Control	PSFSEL[1:0]. Controls the signal bandwidth that is fed to the comb filters (PAL).						0	0	Narrow	
								0	1	Medium	
								1	0	Wide	
								1	1	Widest	
		NSFSEL[1:0]. Controls the signal bandwidth that is fed to the comb filters (NTSC).					0	0			Narrow
							0	1			Medium
							1	0			Medium
							1	1			Wide
				Reserved.							
			1	1	1	1			Set as default		

Table 183. Registers 0x27

Subaddress	Register	Bit Description	Bit							Comments	Notes			
			7	6	5	4	3	2	1			0		
0x27	Pixel Delay Control	LTA[1:0] . Luma timing adjust allows the user to specify a timing difference between chroma and luma samples.											CVBS mode LTA[1:0] = 00b; S-Video mode LTA[1:0] = 01b, YPrPb mode LTA[1:0] = 01b	
									0	0	No Delay			
									0	1	Luma 1 clk (37 ns) delayed			
									1	0	Luma 2 clk (72 ns) early			
								0	1	Luma 1 clk (37 ns) early				
													CVBS mode CTA[2:0] = 011b, S-Video mode CTA[2:0] = 101b, YPrPb mode CTA[2:0] = 110b	
		CTA[2:0] . Chroma timing adjust allows a specified timing difference between the luma and chroma samples.												
					0	0	0							Not a valid setting
					0	0	1							Chroma + 2 pixels (early)
					0	1	0							Chroma + 1 pixel (early)
				0	1	1						No Delay		
				1	0	0						Chroma - 1 pixel (late)		
			1	0	1						Chroma - 2 pixels (late)			
			1	1	0						Chroma - 3 pixels (late)			
			1	1	1						Not a valid setting			
	AUTO_PDC_EN . Automatically programs the LTA/CTA values so that luma and chroma are aligned at output for all modes of operation.		0									Use values in LTA[1:0] and CTA[2:0] for delaying luma/chroma		
			1									LTA and CTA values determined automatically		
	SWPC . Allows the Cr and Cb samples to be swapped.		0									No swapping		
			1									Swap the Cr and Cb		

Table 184. Registers 0x2B and 0x2C

Subaddress	Register	Bit Description	Bit							Comments	Notes			
			7	6	5	4	3	2	1			0		
0x2B	Misc Gain Control	PW_UPD . Peak white update determines the rate of gain.									0	Update once per video line	Peak white must be enabled. See LAGC[2:0].	
											1	Update once per field		
		Reserved.										0		
					1	0	0	0	1					Set to default
		CKE . Color kill enable allows the color kill function to be switched on and off.												For SECAM color kill, threshold is set at 8%.
			0										Color kill disabled	
			1										Color kill enabled	See CKILLTHR[2:0] (Table 192).
		Reserved.												
			1			1	1						Set to default	
		0x2C	AGC Mode Control	CAGC[1:0] . Chroma automatic gain control selects the basic mode of operation for the AGC in the chroma path.								0	0	Manual fixed gain
										0	1	Use luma gain for chroma		
										1	0	Automatic gain	Based on color burst.	
										1	1	Freeze chroma gain		
Reserved.														
							1	1					Set to 1	
LAGC[2:0] . Luma automatic gain control selects the mode of operation for the gain control in the luma path.	0			0	0								Manual fixed gain	Use LMG[11:0].
	0			0	1								AGC no override through white peak. Man IRE control.	Blank level to sync tip.
	0			1	0								AGC auto-override through white peak. Man IRE control.	Blank level to sync tip.
	0			1	1								AGC no override through white peak. Auto IRE control.	Blank level to sync tip.
	1			0	0								AGC auto-override through white peak. Auto IRE control.	Blank level to sync tip.
	1			0	1								AGC active video with white peak	
	1			1	0								AGC active video with average video	
	1			1	1								Freeze gain	
Reserved.														
	1												Set to 1	

Table 185. Registers 0x2D to 0x30

Subaddress	Register	Bit Description	Bit								Comments	Notes	
			7	6	5	4	3	2	1	0			
0x2D	Chroma Gain Control 1	CMG[11:8] . Chroma manual gain can be used to program a desired manual chroma gain. Reading back from this register in AGC mode gives the current gain.									CAGC[1:0] settings decide in which mode CMG[11:0] operates .		
							0	1	0	0			
	Reserved.										Set to 1		
				1	1								
	CAGT[1:0] . Chroma automatic gain timing allows adjustment of the chroma AGC tracking speed.										Has an effect only if CAGC[1:0] is set to auto gain (10).		
		0	0										Slow (TC = 2 s)
		0	1										Medium (TC = 1 s)
		1	0										Fast (TC = 0.2 s)
										Adaptive			
0x2E	Chroma Gain Control 2	CMG[7:0] . Chroma manual gain lower 8 bits. See CMG[11:8] for description.									CMG[11:0] = 750d; gain is 1 in NTSC CMG[11:0] = 741d; gain is 1 in PAL.	Min value is 0d (G = -60 dB) Max value is 3750 (gain = 5).	
			0	0	0	0	0	0	0	0			
0x2F	Luma Gain Control 1	LMG[11:8] . Luma manual gain can be used program a desired manual chroma gain, or to read back the actual gain value used.									LAGC[1:0] settings decide in which mode LMG[11:0] operates.		
							x	x	x	x			
	Reserved.										Set to 1		
				1	1								
	LAGT[1:0] . Luma automatic gain timing allows adjustment of the luma AGC tracking speed.										Only has an effect if AGC[1:0] is set to auto gain (001, 010, 011, or 100)		
		0	0										Slow (TC = 2 s)
		0	1										Medium (TC = 1 s)
		1	0										Fast (TC = 0.2 s)
										Adaptive			
0x30	Luma Gain Control 2	LMG[7:0] . Luma manual gain can be used to program a desired manual chroma gain or read back the actual used gain value.									LMG[11:0] = 1234d; gain is 1 in NTSC LMG[11:0] = 1266d; gain is 1 in PAL.	Min value NTSC 1024 (G = 0.85) PAL (G = 0.81) Max value NTSC 2468 (G = 2), PAL = 2532 (G = 2)	
			x	x	x	x	x	x	x	x			

Table 186. Register 0x31

Subaddress	Register	Bit Description	Bit								Comments	Notes	
			7	6	5	4	3	2	1	0			
0x31	VS and FIELD Control 1	Reserved.											
								0	1	0	Set to default.		
		HVSTIM. Selects where within a line of video the VS signal is asserted.					0						
							1						
		NEWAVMODE. Sets the EAV/SAV mode.				0							EAV/SAV codes generated to suit ADI encoders.
						1							Manual VS/Field position controlled by Registers 0x32, 0x33, and 0xE5–0xEA.
		Reserved.											
			0	0	0							Set to default.	

Table 187. Registers 0x32 and 0x33

Subaddress	Register	Bit Description	Bit								Comments	Notes	
			7	6	5	4	3	2	1	0			
0x32	VSync Field Control 2	Reserved.											
					0	0	0	0	0	0	1	Set to default.	
		VSBHE		0									
				1									
		VSBHO		0									
				1									
0x33	VSync Field Control 3	Reserved.											
					0	0	0	1	0	0	Set to default.		
		VSEHE		0									
				1									
		VSEHO		0									
				1									

ADV7181

Table 188. Registers 0x34 to 0x36

Subaddress	Register	Bit Description	Bit								Comments	Notes		
			7	6	5	4	3	2	1	0				
0x34	HS Position Control 1												HS output ends HSE[10:0] pixels after the falling edge of HSync.	Using HSB and HSE, the user can program the position and length of the output HSync.
		HSE[10:8]. HS end allows the positioning of the HS output within the video line.						0	0	0				
		Reserved.												
							0							
		HSB[10:8]. HS begin allows the positioning of the HS output within the video line.		0	0	0								
		Reserved.												
0x35	HS Position Control 2	HSB[7:0] See above, using HSB[9:0] and HSE[9:0] the user can program the position and length of HS output signal.	0	0	0	0	0	0	1	0				
		Reserved.	0								Set to 0.			
0x36	HS Position Control 3	HSE[7:0] See above.	0	0	0	0	0	0	0	0				
		Reserved.	0								Set to 0.			

Table 189. Register 0x37

Subaddress	Register	Bit Description	Bit								Comments		
			7	6	5	4	3	2	1	0			
0x37	Polarity	PCLK. Sets the polarity of LLC1.											
												0	Invert polarity
												1	Normal polarity as per Timing Diagrams
		Reserved.											
										0	0	Set to 0	
		PF. Sets the FIELD polarity.											
									0			Active high	
									1			Active low	
		Reserved.											
							0					Set to 0	
		PVS. Sets the VS polarity.											
						0						Active high	
						1						Active low	
		Reserved.											
							0					Set to 0	
		PHS. Sets HS polarity.											
								0		Active high			
								1		Active low			

Table 190. Register 0x38

Subaddress	Register	Bit Description	Bit							Comments	Notes		
			7	6	5	4	3	2	1			0	
0x38	NTSC Comb Control	YCMN[2:0] . Luma Comb Mode, NTSC.											
								0	0	0	Adaptive 3-line, 3-tap luma		
								1	0	0	Use low-pass notch		
								1	0	1	Fixed luma comb (2-line)	Top lines of memory	
								1	1	0	Fixed luma comb (3-line)	All lines of memory	
							1	1	1	Fixed luma comb (2-line)	Bottom lines of memory		
				CCMN[2:0] . Chroma Comb Mode, NTSC.			0	0	0			3-line adaptive for CTAPSN = 01	
												4-line adaptive for CTAPSN = 10	
												5-line adaptive for CTAPSN = 11	
							1	0	0			Disable chroma comb	
							1	0	1			Fixed 2-line for CTAPSN = 01	Top lines of memory
												Fixed 3-line for CTAPSN = 10	
												Fixed 4-line for CTAPSN = 11	
							1	1	0			Fixed 3-line for CTAPSN = 01	All lines of memory
												Fixed 4-line for CTAPSN = 10	
												Fixed 5-line for CTAPSN = 11	
							1	1	1			Fixed 2-line for CTAPSN = 01	Bottom lines of memory
												Fixed 3-line for CTAPSN = 10	
											Fixed 4-line for CTAPSN = 11		
				CTAPSN[1:0] . Chroma Comb Taps, NTSC.	0	0						Not used	
					0	1						Adapts 3 lines – 2 lines	
					1	0						Adapts 5 lines – 3 lines	
					1	1						Adapts 5 lines – 4 lines	

Table 191. Registers 0x39 and 0x3A

Subaddress	Register	Bit Description	Bit								Comments	Notes
			7	6	5	4	3	2	1	0		
0x39	PAL Comb Control	YCMP[2:0] . Luma Comb mode, PAL.						0	0	0	Adaptive 5-line, 3-tap luma comb	
								1	0	0	Use low-pass notch	
								1	1	0	Fixed luma comb	Top lines of memory
								1	1	0	Fixed luma comb (5-line)	All lines of memory
								1	1	1	Fixed luma comb (3-line)	Bottom lines of memory
		CCMP[2:0] . Chroma Comb mode, PAL.			0	0	0				3-line adaptive for CTAPSN = 01 4-line adaptive for CTAPSN = 10 5-line adaptive for CTAPSN = 11	
					1	0	0				Disable chroma comb	
					1	0	1				Fixed 2-line for CTAPSN = 01 Fixed 3-line for CTAPSN = 10 Fixed 4-line for CTAPSN = 11	Top lines of memory
					1	1	0				Fixed 3-line for CTAPSN = 01 Fixed 4-line for CTAPSN = 10 Fixed 5-line for CTAPSN = 11	All lines of memory
		CTAPSP[1:0] . Chroma comb taps, PAL.	0	0							Not used	
	0		1							Adapts 5-lines – 2 lines (2 taps)		
	1		0							Adapts 5 lines – 3 lines (3 taps)		
	1		1							Adapts 5 lines – 4 lines (4 taps)		
	0x3A	ADC Control	Reserved.							0	Set as default	
PWRDN_ADC_2 . Enables power down of ADC2.									0	ADC2 normal operation		
									1	Power down ADC2		
PWRDN_ADC_1 . Enables power down of ADC1.									0	ADC1 normal operation		
									1	Power down ADC1		
PWRDN_ADC_0 . Enables power down of ADC0.									0	ADC0 normal operation		
							1	Power down ADC0				
	Reserved.	0	0	0	1					Set as default		

Table 192. Register 0x3D

Subaddress	Register	Bit Description	Bit								Comments	Notes	
			7	6	5	4	3	2	1	0			
0x3D	Manual Window	Reserved.											
						0	0	1	1			Set to default	
		CKILLTHR[2:0].											
				0	0	0							Kill at 0.5%
				0	0	1							Kill at 1.5%
				0	1	0							Kill at 2.5%
				0	1	1							Kill at 4%
				1	0	0							Kill at 8.5%
				1	0	1							Kill at 16%
				1	1	0							Kill at 32%
		Reserved.									Reserved		
		Reserved.	0									Set to default	

Table 193. Registers 0x41 to 0x4C

Subaddress	Register	Bit Description	Bit								Comments	Notes	
			7	6	5	4	3	2	1	0			
0x41	Resample Control	Reserved.											
					0	1	0	0	0	0	0		Set to default
		SFL_INV. Controls the behavior of the PAL switch bit.		0									SFL-compatible with ADV7190/ADV7191/ADV7194 encoders
				1									SFL-compatible with ADV717x/ADV7173x encoders
		Reserved.											
			0									Set to default	
0x48	Gemstar Control 1	GDECEL[15:0]. 16 individual enable bits that select the lines of video (even field Lines 10–25) that the decoder checks for Gemstar-compatible data.											LSB = Line 10 MSB = Line 25 Default = Do not check for Gemstar-compatible data on any lines [10–25] in even fields
		GDECEL[15:8]. See above.	0	0	0	0	0	0	0	0	0		
0x49	Gemstar Control 2	GDECEL[7:0]. See above.											
			0	0	0	0	0	0	0	0	0		
0x4A	Gemstar Control 3	GDECOL[15:0]. 16 individual enable bits that select the lines of video (odd field lines 10–25) that the decoder checks for Gemstar-compatible data.											LSB = Line 10 MSB = Line 25 Default = Do not check for Gemstar-compatible data on any lines [10–25] in odd fields
		GDECOL[15:8]. See above.	0	0	0	0	0	0	0	0	0		
0x4B	Gemstar Control 4	GDECOL[7:0]. See above.											
			0	0	0	0	0	0	0	0	0		
0x4C	Gemstar Control 5	GDECAD. Controls the manner in which decoded Gemstar data is inserted into the horizontal blanking period.										0	Split data into half byte
												1	Output in straight 8-bit format
		Reserved.	x	x	x	x	x	x	x	x			Undefined

ADV7181

Table 194. Registers 0x4D to 0x50

Subaddress	Register	Bit Description	Bit								Comments			
			7	6	5	4	3	2	1	0				
0x4D	CTI DNR Control 1	CTI_EN. CTI enable.												
												0	Disable CTI	
												1	Enable CTI	
		CTI_AB_EN. Enables the mixing of the transient improved chroma with the original signal.										0	Disable CTI alpha blender	
												1	Enable CTI alpha blender	
			CTI_AB[1:0]. Controls the behavior of the alpha-blend circuitry.						0	0				Sharpest mixing
									0	1				Sharp mixing
								1	0				Smooth	
		Reserved.						1	1				Smoothest	
							0						Set to default	
		DNR_EN. Enable or bypass the DNR block.				0							Bypass the DNR block	
						1							Enable the DNR block	
			Reserved.		1								Set to default	
		Reserved.										1	Set to default	
0x4E	CTI DNR Control 2	CTI_CTH[7:0]. Specifies how big the amplitude step must be to be steepened by the CTI block.	0	0	0	0	1	0	0	0				
0x50	CTI DNR Control 4	DNR_TH[7:0]. Specifies the maximum edge that is interpreted as noise and is therefore blanked.	0	0	0	0	1	0	0	0	Set to 0x04 for A/V input; set to 0x0A for tuner input.			

Table 195. Register 0x51

Subaddress	Register	Bit Description	Bit								Comments	Notes				
			7	6	5	4	3	2	1	0						
0x51	Lock Count	CIL[2:0] . Count-into-lock determines the number of lines the system must remain in lock before showing a locked status.														
								0	0	0				1 line of video		
								0	0	1						2 lines of video
								0	1	0						5 lines of video
								0	1	1						10 lines of video
								1	0	0						100 lines of video
								1	0	1						500 lines of video
								1	1	0						1000 lines of video
							1	1	1					100000 lines of video		
				COL[2:0] . Count-out-of-lock determines the number of lines the system must remain out-of-lock before showing a lost-locked status.			0	0	0							1 line of video
							0	0	1							2 lines of video
							0	1	0							5 lines of video
							0	1	1							10 lines of video
							1	0	0							100 lines of video
						1	0	1						500 lines of video		
						1	1	0						1000 lines of video		
					1	1	1						100000 lines of video			
			SRLS . Select raw lock signal. Selects the determination of the lock status.													
					0											Over field with vertical info
				1										Line-to-line evaluation		
			FSCLE . Fsc lock enable.													FSCLE must be set to 0 in YPrPb mode if a reliable LOST_LOCK bit is set to 0.
				0										Lock status set only by horizontal lock		
				1										Lock status set by horizontal lock and subcarrier lock		

ADV7181

Table 196. Registers 0x8F and 0x90

Subaddress	Register	Bit Description	Bit							Comments	Notes		
			7	6	5	4	3	2	1			0	
0x8F	Free Run Line Length 1	Reserved.											
							0	0	0	0	Set to default		
		LLC_PAD_SEL [2:0] . Enables manual selection of clock for LLC1 pin.		0	0	0					LLC1 (nominally 27 MHz) selected out on LLC1 pin		
				1	0	1					LLC2 (nominally 13.5 MHz) selected out on LLC1 pin	For 16-bit 4:2:2 out, OF_SEL[3:0] = 0010	
		Reserved.	0								Set to default		
0x90	VBI Info Read Mode Details	WSSD . Screen signaling detected.									0	No WSS detected	Ready-only status bits
											1	WSS detected	
		CCAPD . Closed caption data.									0	No CCAP signals detected	
											1	CCAP sequence detected	
		EDTVD . EDTV sequence.									0	No EDTV sequence detected	
											1	EDTV sequence detected	
		CGMSD . CGMS sequence.									0	No CGMS transition detected	
											1	CGMS sequence decoded	
		Reserved.											
			x	x	x	x							

Table 197. Registers 0x91 to 0x9D

Subaddress	Register	Bit Description	Bit								Comments	Notes
			7	6	5	4	3	2	1	0		
0x91	WSS1[7:0]. Wide screen signaling data. Read-only.	WSS1[7:0]	x	x	x	x	x	x	x	x		
0x92	WSS2[7:0]. Wide screen signaling data. Read-only.	WSS2[7:0]	x	x	x	x	x	x	x	x	WSS2[7:6] are undetermined.	
0x93	EDTV1[7:0]. EDTV data. Read-only.	EDTV1[7:0]	x	x	x	x	x	x	x	x		
0x94	EDTV2[7:0]. EDTV data. Read-only.	EDTV2[7:0]	x	x	x	x	x	x	x	x		
0x95	EDTV3[7:0]. EDTV data. Read-only.	EDTV3[7:0]	x	x	x	x	x	x	x	x	EDTV3[7:6] are undetermined.	EDTV3[5] is reserved for future use.
0x96	CGMS1[7:0]. CGMS data. Read-only.	CGMS1[7:0]	x	x	x	x	x	x	x	x		
0x97	CGMS2[7:0]. CGMS data. Read-only.	CGMS2[7:0]	x	x	x	x	x	x	x	x		
0x98	CGMS3[7:0]. CGMS data. Read-only.	CGMS3[7:0]	x	x	x	x	x	x	x	x	CGMS3[7:4] are undetermined.	
0x99	CCAP1[7:0]. Closed caption data. Read-only.	CCAP1[7:0]	x	x	x	x	x	x	x	x	CCAP1[7] contains parity bit for Byte 0.	
0x9A	CCAP2[7:0]. Closed caption data. Read-only.	CCAP2[7:0]	x	x	x	x	x	x	x	x	CCAP2[7] contains parity bit for Byte 0.	
0x9B	Letterbox 1. Read-only.	LB_LCT[7:0]	x	x	x	x	x	x	x	x	Reports the number of black lines detected at top of active video.	This feature examines the active video at the start and at the end of each field. It enables format detection even if the video is not accompanied by a CGMS or WSS sequence.
0x9C	Letterbox 2. Read-only.	LB_LCM[7:0]	x	x	x	x	x	x	x	x	Reports the number of black lines detected in the bottom half of active video if subtitles are detected.	
0x9D	Letterbox 3. Read-only.	LB_LCB[7:0]	x	x	x	x	x	x	x	x	Reports the number of black lines detected at the bottom of active video.	

Table 198. Register 0xB2

Subaddress	Register	Bit Description	Bit								Comments	
			7	6	5	4	3	2	1	0		
0xB2	CRC Enable Write	Reserved.										
								0	0		Set as default.	
		CRC_ENABLE. Enables CRC checksum decoded from CGMS packet to validate CGMSD.						0			Turn off CRC check.	
								1			CGMSD goes high with valid checksum.	
		Reserved.						0	0	0	1	1

ADV7181

Table 199. Register 0xC3

Subaddress	Register	Bit Description	Bit								Comment (default)	Note		
			7	6	5	4	3	2	1	0				
0xC3	ADC SWITCH 1	ADC0_SW[3:0] . Manual muxing control for ADC0.					0	0	0	0	NC	SETADC_sw_man_en = 1		
							0	0	0	1	AIN2			
							0	0	1	0	NC			
							0	0	1	1	NC			
							0	1	0	0	AIN4			
							0	1	0	1	AIN6			
							0	1	1	0	NC			
							0	1	1	1	NC			
							1	0	0	0	NC			
							1	0	0	1	AIN1			
							1	0	1	0	NC			
							1	0	1	1	NC			
							1	1	0	0	AIN3			
							1	1	0	1	AIN5			
							1	1	1	0	NC			
						1	1	1	1	NC				
				ADC1_SW[3:0] . Manual muxing control for ADC1.	0	0	0	0					NC	
						0	0	0	1					NC
						0	0	1	0					NC
						0	0	1	1					NC
						0	1	0	0					AIN4
						0	1	0	1					AIN6
						0	1	1	0					NC
						0	1	1	1					NC
						1	0	0	0					NC
						1	0	0	1					NC
						1	0	1	0					NC
						1	0	1	1					NC
						1	1	0	0					AIN3
						1	1	0	1					AIN5
			1		1	1	0				NC			
			1	1	1	1				NC				

NC = no connection.

Table 200. Register 0xC4

Subaddress	Register	Bit Description	Bit								Comments (default)	Notes		
			7	6	5	4	3	2	1	0				
0xC4	ADC SWITCH 2	ADC_SW[3:0] . Manual muxing control for ADC2.					0	0	0	0	NC	SETADC_sw_man_en = 1		
							0	0	0	1	NC			
							0	0	1	0	NC			
							0	0	1	1	NC			
							0	1	0	0	NC			
							0	1	0	1	AIN6			
							0	1	1	0	NC			
							0	1	1	1	NC			
							1	0	0	0	NC			
							1	0	0	1	NC			
							1	0	1	0	NC			
							1	0	1	1	NC			
							1	1	0	0	NC			
							1	1	0	1	AIN5			
							1	1	1	0	NC			
							1	1	1	1	NC			
					Reserved.									
						x	x	x						
					ADC_SW_MAN_EN . Enable manual setting of the input signal muxing.									
				0							Disable			
			1							Enable				

NC = no connection.

ADV7181

Table 201. Registers 0xDC to 0xE4

Subaddress	Register	Bit Description	Bit							Comments	
			7	6	5	4	3	2	1		0
0xDC	Letterbox Control 1	LB_TH [4:0] . Sets the threshold value that detects a black.				0	1	1	0	0	Default threshold for detection of black lines.
		Reserved.									
			1	0	1						Set as default.
0xDD	Letterbox Control 2	LB_EL[3:0] . Programs the end line of the activity window for LB detection (end of field).					1	1	0	0	LB detection ends with the last line of active video on a field. 1100: 262/525.
		LB_SL[3:0] . Programs the start line of the activity window for LB detection (start of field).	0	1	0	0					
		Reserved.									
0xDE		Reserved.	0	0	0	0	0	0	0	0	
0xDF		Reserved.	0	0	0	0	0	0	0	0	
0xE0		Reserved.	0	0	0	1	0	1	0	0	
0xE1	SD Offset Cb	SD_OFF_CB [7:0] . Adjusts hue by selecting offset for the Cb channel.	1	0	0	0	0	0	0	0	
0xE2	SD Offset Cr	SD_OFF_CR [7:0] . Adjusts hue by selecting offset for the Cr channel.	1	0	0	0	0	0	0	0	
0xE3	SD Saturation Cb	SD_SAT_CB [7:0] . Adjusts saturation of the picture by affecting gain on the Cb channel.	1	0	0	0	0	0	0	0	Chroma gain = 0 dB
0xE4	SD Saturation Cr	SD_SAT_CR [7:0] . Adjusts saturation of the picture by affecting gain on the Cr channel.	1	0	0	0	0	0	0	0	Chroma gain = 0 dB

Table 202. Registers 0xE5 to 0xE7

Subaddress	Register	Bit Description	Bit							Comments			
			7	6	5	4	3	2	1		0		
0xE5	NTSC V Bit Begin	NVBEG[4:0]. How many lines after I _{COUNT} rollover to set V high.				0	0	1	0	1	NTSC default (BT.656)		
		NVBEGSIGN.			0						Set to low when manual programming		
					1						Not suitable for user programming		
		NVBEGDELE. Delay V bit going high by one line relative to NVBEG (even field).		0							No delay		
				1							Additional delay by 1 line		
		NVBEGDELO. Delay V bit going high by one line relative to NVBEG (odd field).	0								No delay		
			1								Additional delay by 1 line		
		0xE6	NTSC V Bit End	NVEND[4:0]. How many lines after I _{COUNT} rollover to set V low.				0	0	1	0	0	NTSC default (BT.656)
				NVENDSIGN.			0						Set to low when manual programming
							1						Not suitable for user programming
NVENDDELE. Delay V bit going low by one line relative to NVEND (even field).				0							No delay		
				1							Additional delay by 1 line		
NVENDDELO. Delay V bit going low by one line relative to NVEND (odd field).	0										No delay		
	1										Additional delay by 1 line		
0xE7	NTSC F Bit Toggle			NFTOG[4:0]. How many lines after I _{COUNT} rollover to toggle F signal.				0	0	0	1	1	NTSC default
				NFTOGSIGN.			0						Set to low when manual programming
							1						Not suitable for user programming
		NFTOGDELE. Delay F transition by one line relative to NFTOG (even field).		0							No delay		
				1							Additional delay by 1 line		
		NFTOGDELO. Delay F transition by one line relative to NFTOG (odd field).	0								No delay		
			1								Additional delay by 1 line		

Table 203. Registers 0xE8 to 0xEA

Subaddress	Register	Bit Description	Bit								Comments		
			7	6	5	4	3	2	1	0			
0xE8	PAL V Bit Begin	PVBEG[4:0]. How many lines after I _{COUNT} rollover to set V high.				0	0	1	0	1	PAL default (BT.656)		
		PVBEGSIGN.			0						Set to low when manual programming		
					1						Not suitable for user programming		
		PVBEGDELE. Delay V bit going high by one line relative to PVBEG (even field).		0							No delay		
				1							Additional delay by 1 line		
		PVBEGDELO. Delay V bit going high by one line relative to PVBEG (odd field).	0								No delay		
			1								Additional delay by 1 line		
		0xE9	PAL V Bit End	PVEND[4:0]. How many lines after I _{COUNT} rollover to set V low.				1	0	1	0	0	PAL default (BT.656)
				PVENDSIGN.			0						Set to low when manual programming
							1						Not suitable for user programming
PVENDDELE. Delay V bit going low by one line relative to PVEND (even field).				0							No delay		
				1							Additional delay by 1 line		
PVENDDELO. Delay V bit going low by one line relative to PVEND (odd field).	0										No delay		
	1										Additional delay by 1 line		
0xEA	PAL F Bit Toggle			PFTOG[4:0]. How many lines after I _{COUNT} rollover to toggle F signal.				0	0	0	1	1	PAL default (BT.656)
				PFTOGSIGN.			0						Set to low when manual programming
							1						Not suitable for user programming
		PFTOGDELE. Delay F transition by one line relative to PFTOG (even field).		0							No delay		
				1							Additional delay by 1 line		
		PFTOGDELO. Delay F transition by one line relative to PFTOG (odd field).	0								No delay		
			1								Additional delay by 1 line		

I²C PROGRAMMING EXAMPLES

MODE 1—CVBS INPUT (COMPOSITE VIDEO ON AIN6)

All standards are supported through autodetect, 8-bit, 4:2:2, ITU-R BT.656 output on P15–P8.

Table 204. Mode 1—CVBS Input

Register Address	Register Value	Notes
0x00	0x04	CVBS input
0x01	0x88	Turn off Hsync processor (SECAM only ⁴).
0x17	0x41	Set CSFM to SH1.
0x2B	0xE2	AGC flash tweak.
0x3A	0x16	Power down ADC 1 and ADC 2.
0x50	0x04	Set DNR threshold.
0x51	0x24	Turn off FSC detect for IN LOCK status.
0xC3	0x05	Man mux AIN6 to ADC0 (0101).
0xC4	0x80	Set setadc_sw_man_en = 1.
0xD2	0x01	AGC flash tweak.
0xD3	0x01	AGC flash tweak.
0xDB	0x9B	AGC flash tweak.
0x0E	0x85	ADI recommended programming sequence. This sequence must be followed exactly when setting up the decoder.
0x89	0x0D	Recommended setting.
0x8D	0x9B	Recommended setting.
0x8F	0x48	Recommended setting.
0xB5	0x8B	Recommended setting.
0xD4	0xFB	Recommended setting.
0xD6	0x6D	Recommended setting.
0xE2	0xAF	Recommended setting.
0xE3	0x00	Recommended setting.
0xE4	0xB5	Recommended setting.
0xE8	0xF3	Recommended setting.
0x0E	0x05	Recommended setting.

⁴ For all SECAM modes of operation, Hsync processor must be turned off.

MODE 2—S-VIDEO INPUT (Y ON AIN1 AND C ON AIN4)

All standards are supported through autodetect, 8-bit, ITU-R BT.656 output on P15–P8.

Table 205. Mode 2—S-Video Input

Register Address	Register Value	Notes
0x00	0x06	S-Video input.
0x01	0x88	Turn off HSYNC processor (SECAM only). ¹
0x2B	0xE2	AGC flash tweak.
0x3A	0x12	Power down ADC 2.
0x50	0x04	Set DNR threshold.
0x51	0x24	Turn off FSC detect for IN LOCK status.
0xC3	0x41	Man mux AIN2 to ADC0 (0001), AIN4 to ADC1 (0100).
0xC4	0x80	Set setadc_sw_man_en = 1.
0xD2	0x01	AGC flash tweak.
0xD3	0x01	AGC flash tweak.
0xDB	0x9B	AGC flash tweak.
0x0E	0x85	ADI recommended programming sequence. This sequence must be followed exactly when setting up the decoder.
0xB5	0x8B	Recommended setting.
0xD4	0xFB	Recommended setting.
0xD6	0x6D	Recommended setting.
0xE2	0xAF	Recommended setting.
0xE3	0x00	Recommended setting.
0xE4	0xB5	Recommended setting.
0xE8	0xF3	Recommended setting.
0x0E	0x05	Recommended setting.

¹ For all SECAM modes of operation, the Hsync processor must be turned off.

MODE 3—525i/625i YPrPb INPUT (Y ON AIN1, Pr ON AIN3, AND Pb ON AIN5)

All standards are supported through autodetect, 8-bit, ITU-R BT.656 output on P15–P8.

Table 206. Mode 3—YPrPb Input 525i/625i

Register Address	Register Value	Notes
0x00	0x0A	Y2 = AIN2, Pr2 = AIN3, Pb2 = AIN6.
0x01	0x88	Disable HSync PLL. ¹
0x2B	0xE2	AGC flash tweak.
0x3A	0x10	Set latch clock.
0x51	0x24	Turn off FSC detect for IN LOCK status.
0xC3	0xC9	Man mux AIN1 to ADC0 (1001), AIN3 to ADC1 (1100).
0xC4	0x8D	Set setadc_sw_man_en = 1.
0xD2	0x01	AGC flash tweak.
0xD3	0x01	AGC flash tweak.
0xDB	0x9B	AGC flash tweak.
0x0E	0x85	ADI recommended programming sequence. This sequence must be followed exactly when setting up the decoder.
0xD6	0x6D	Recommended setting.
0xE8	0xF3	Recommended setting.
0x0E	0x05	Recommended setting.

¹ For all YPrPb input modes of operation, the Hsync processor must be turned off.

MODE 4—CVBS TUNER INPUT CVBS PAL ON AIN6

8-bit, ITU-R BT.656 output on P15–P8.

Table 207. Mode 4—Tuner Input CVBS PAL Only

Register Address	Register Value	Notes
0x07	0x01	Enable PAL autodetection only.
0x17	0x41	Set CSFM to SH1.
0x2B	0xE2	AGC flash tweak.
0x19	0xFA	Stronger dot crawl reduction.
0x3A	0x16	Power down ADC 1 and ADC 2.
0x50	0x0A	Set higher DNR threshold.
0x51	0x24	Turn off FSC detect for IN LOCK status.
0xC3	0x05	Man mux AIN6 to ADC0 (0101).
0xC4	0x80	Set setadc_sw_man_en = 1.
0xD2	0x01	AGC flash tweak.
0xD3	0x01	AGC flash tweak.
0xDB	0x9B	AGC flash tweak.
0x0E	0x85	ADI recommended programming sequence. This sequence must be followed exactly when setting up the decoder.
0x89	0x0D	Recommended setting.
0x8D	0x9B	Recommended setting.
0x8F	0x48	Recommended setting.
0xB5	0x8B	Recommended setting.
0xD4	0xFB	Recommended setting.
0xD6	0x6D	Recommended setting.
0xE2	0xAF	Recommended setting.
0xE3	0x00	Recommended setting.
0xE4	0xB5	Recommended setting.
0xE8	0xF3	Recommended setting.
0x0E	0x05	Recommended setting.

PCB LAYOUT RECOMMENDATIONS

The ADV7181 is a high precision, high speed mixed-signal device. To achieve the maximum performance from the part, it is important to have a well laid out PCB board. The following is a guide for designing a board using the ADV7181.

ANALOG INTERFACE INPUTS

The inputs should receive care when being routed on the PCB. Track lengths should be kept to a minimum, and 75 Ω trace impedances should be used when possible. Trace impedances other than 75 Ω also increase the chance of reflections.

POWER SUPPLY DECOUPLING

It is recommended to decouple each power supply pin with 0.1 μF and 10 nF capacitors. The fundamental idea is to have a decoupling capacitor within about 0.5 cm of each power pin. Also, avoid placing the capacitor on the opposite side of the PCB board from the ADV7181; doing so interposes resistive vias in the path. The decoupling capacitors should be located between the power plane and the power pin. Current should flow from the power plane to the capacitor to the power pin. Do not make the power connection between the capacitor and the power pin. Placing a via underneath the 100 nF capacitor pads, down to the power plane, is generally the best approach (see Figure 37).

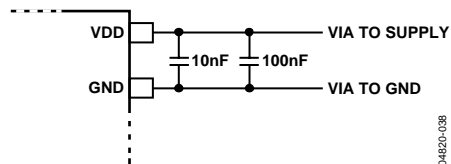

Figure 37. Recommend Power Supply Decoupling

It is particularly important to maintain low noise and good stability of PVDD. Careful attention must be paid to regulation, filtering, and decoupling. It is highly desirable to provide separate regulated supplies for each of the analog circuitry groups (AVDD, DVDD, DVDDIO, and PVDD).

Some graphic controllers use substantially different levels of power when active (during active picture time) and when idle (during horizontal and vertical sync periods). This can result in a measurable change in the voltage supplied to the analog supply regulator, which can, in turn, produce changes in the regulated analog supply voltage. This can be mitigated by regulating the analog supply, or at least PVDD, from a different, cleaner, power source, for example, from a 12 V supply.

It is also recommend to use a single ground plane for the entire board. This ground plane should have a spacing gap between the analog and digital sections of the PCB (see Figure 38).

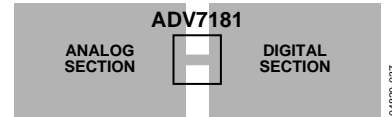

Figure 38. PCB Ground Layout

Experience has repeatedly shown that the noise performance is the same or better with a single ground plane. Using multiple ground planes can be detrimental because each separate ground plane is smaller, and long ground loops can result.

In some cases, using separate ground planes is unavoidable. For those cases, it is recommended to at least place a single ground plane under the ADV7181. The location of the split should be under the ADV7181. For this case, it is even more important to place components wisely because the current loops are much longer (current takes the path of least resistance). An example of a current loop: power plane to ADV7181 to digital output trace to digital data receiver to digital ground plane to analog ground plane.

PLL

Place the PLL loop filter components as close to the ELPF pin as possible. Do not place any digital or other high frequency traces near these components. Use the values suggested in the data sheet with tolerances of 10% or less.

DIGITAL OUTPUTS (BOTH DATA AND CLOCKS)

Try to minimize the trace length that the digital outputs have to drive. Longer traces have higher capacitance, which requires more current, which causes more internal digital noise. Shorter traces reduce the possibility of reflections.

Adding a 30 Ω and 50 Ω series resistor can suppress reflections, reduce EMI, and reduce the current spikes inside the ADV7181. If series resistors are used, place them as close as possible to the ADV7181 pins. However, try not to add vias or extra length to the output trace to make the resistors closer.

If possible, limit the capacitance that each of the digital outputs drives to less than 15 pF. This can easily be accomplished by keeping traces short and by connecting the outputs to only one device. Loading the outputs with excessive capacitance increases the current transients inside the ADV7181, creating more digital noise on its power supplies.

DIGITAL INPUTS

The digital inputs on the ADV7181 were designed to work with 3.3 V signals, and are not tolerant of 5 V signals. Extra components are needed if 5 V logic signals are required to be applied to the decoder.

Antialiasing Filters

For inputs from some video sources that are not bandwidth limited, signals outside the video band can alias back into the video band during A/D conversion and appear as noise on the output video. The ADV7181 oversamples the analog inputs by a factor of 4. This 54 MHz sampling frequency reduces the requirement for an input filter; for optimal performance it is recommended that an antialiasing filter be used. The recommended low cost circuit for implementing this buffer and filter circuit for all analog input signals is shown in Figure 41.

The buffer is a simple emitter-follower using a single npn transistor. The antialiasing filter is implemented using passive components. The passive filter is a third-order Butterworth filter with a -3 dB point of 9 MHz. The frequency response of the passive filter is shown in Figure 39. The flat pass band up to 6 MHz is essential. The attenuation of the signal at the output of the filter due to the voltage divider of R24 and R63 is compensated for in the ADV7181 part using the automatic gain control. The ac coupling capacitor at the input to the buffer creates a high-pass filter with the biasing resistors for the transistor. This filter has a cutoff of

$$\{2 \times \pi \times (R39 || R89) \times C93\}^{-1} = 0.62 \text{ Hz}$$

It is essential that the cutoff of this filter be less than 1 Hz to ensure correct operation of the internal clamps within the part. These clamps ensure that the video stays within the 5 V range of the op amp used.

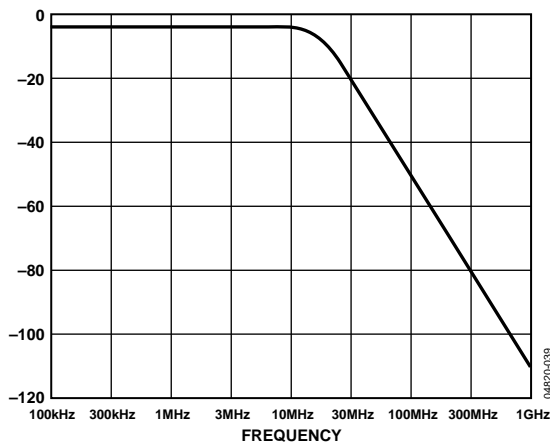

Figure 39. Third-Order Butterworth Filter Response

XTAL AND LOAD CAPACITOR VALUE SELECTION

Figure 40 shows an example reference clock circuit for the ADV7181. Special care must be taken when using a crystal circuit to generate the reference clock for the ADV7181. Small variations in reference clock frequency can cause autodetection issues and impair the ADV7181 performance.

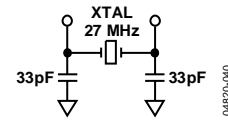

Figure 40. Crystal Circuit

Use the following guidelines to ensure correct operation:

- Use the correct frequency crystal, which is 27 MHz. Tolerance should be 50 ppm or better.
- Use a parallel-resonant crystal.
- Know the C_{load} for the crystal part number selected. The value of Capacitors C1 and C2 must match C_{load} for the specific crystal part number in the user's system.

To find C_{load}, use the following formula:

$$C1 = C2 = 2C_{load} - C_{stray}$$

where C_{stray} is 3 pF to 8 pF, depending on board traces.

Example

$$C_{load} = 20 \text{ pF}$$

$$C1 = 33 \text{ pF}$$

$$C2 = 33 \text{ pF}$$

TYPICAL CIRCUIT CONNECTION

Examples of how to connect the ADV7181 video decoder are shown in Figure 41 and Figure 42.

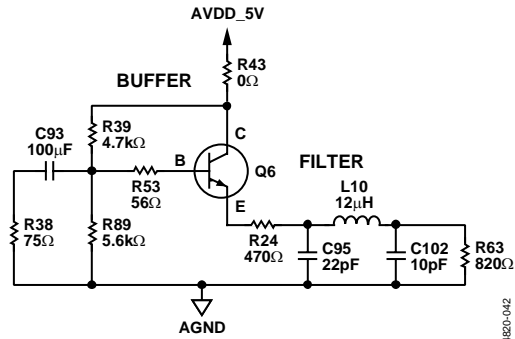

Figure 41. ADI Recommended Antialiasing Circuit for All Input Channels

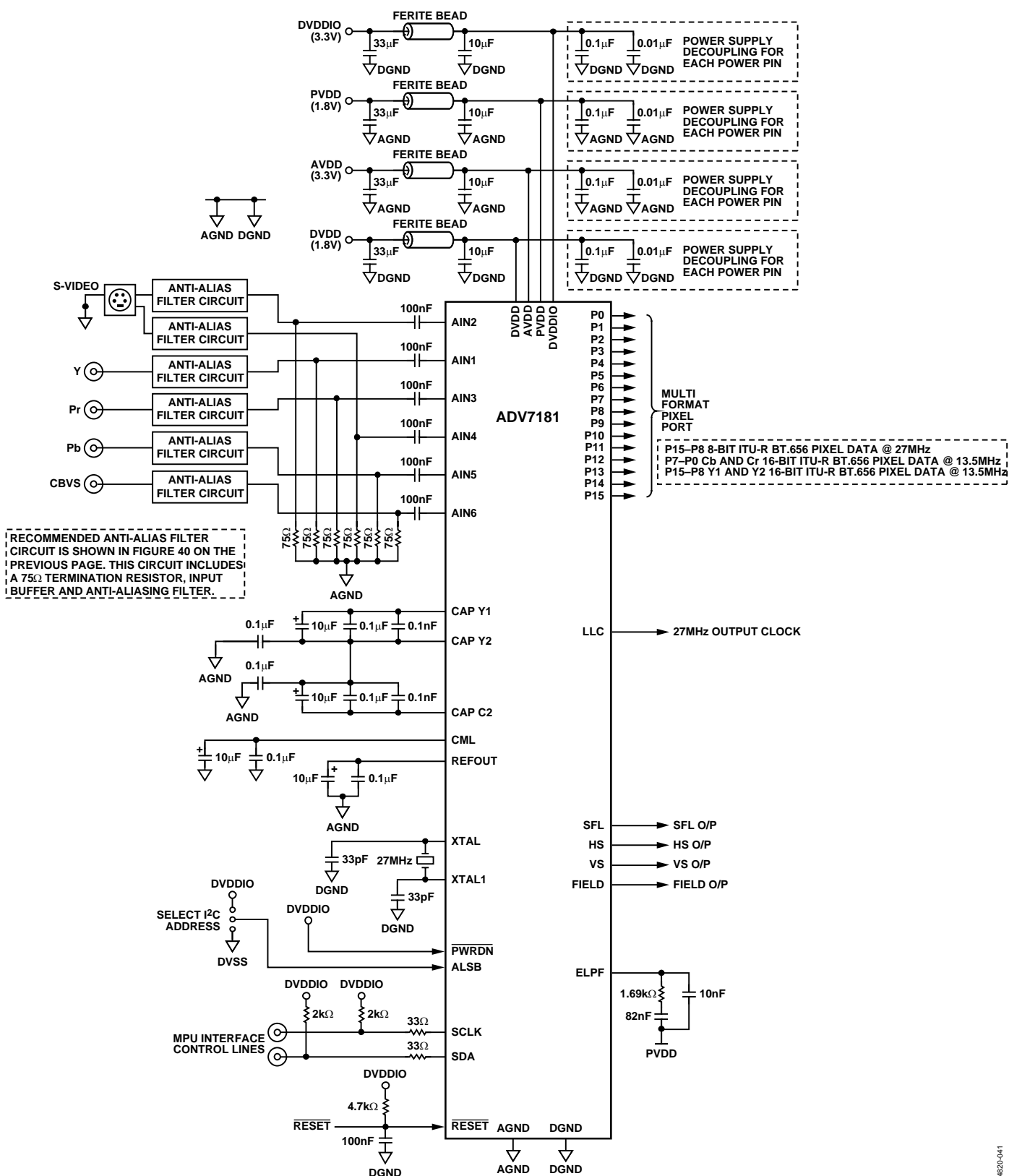

Figure 42. Typical Connection Diagram

OUTLINE DIMENSIONS

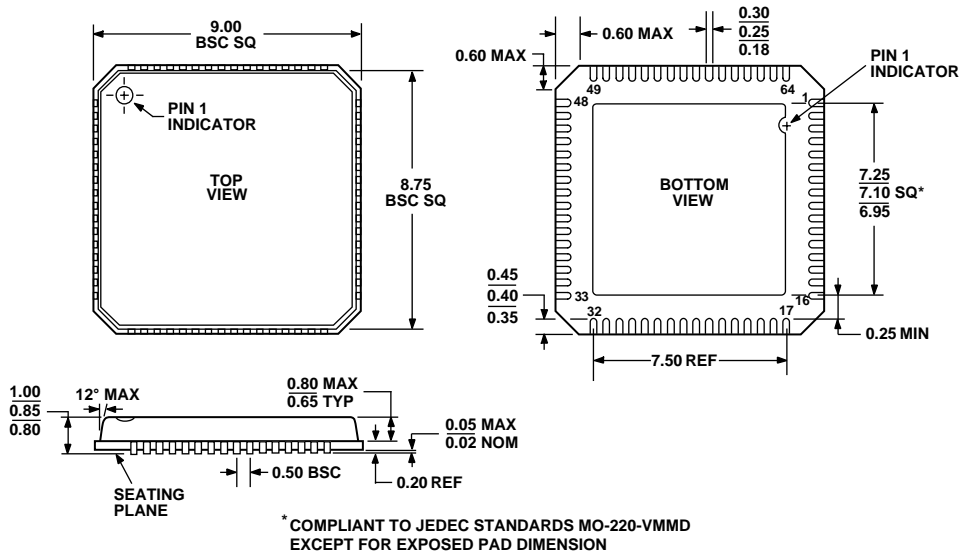

Figure 43. 64-Lead Lead Frame Chip Scale Package [LFCSP]
 9 mm × 9 mm Body
 (CP-64-3)
 Dimensions shown in millimeters

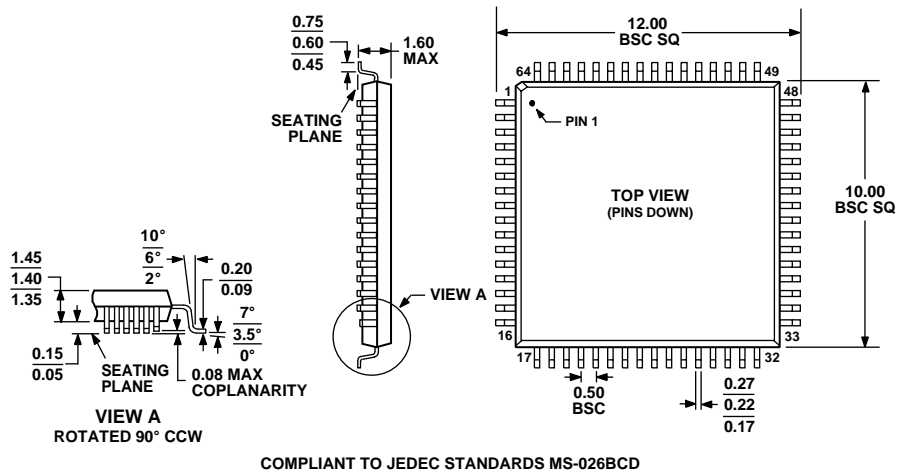

Figure 44. 64-Lead Low Profile Quad Flat Package [LQFP]
 (ST-64-2)
 Dimensions shown in Millimeters

ORDERING GUIDE

Model	Temperature Range	Package Description	Package Option
ADV7181BCP	-40°C to +85°C	Lead Frame Chip Scale Package (LFCSP)	CP-64-3
ADV7181BST	-40°C to +85°C	Low Profile Quad Flat Package (LQFP)	ST-64-2
EVAL-ADV7181BEB		Evaluation Board	

The ADV7181 is a Pb-free environmentally friendly product. It is manufactured using the most up-to-date materials and processes. The coating on the leads of each device is 100% pure Sn electroplate. The device is suitable for Pb-free applications, and can withstand surface-mount soldering at up to 255°C ($\pm 5^\circ\text{C}$).

In addition, it is backward-compatible with conventional SnPb soldering processes. This means the electroplated Sn coating can be soldered with Sn/Pb solder pastes at conventional reflow temperatures of 220°C to 235°C.

The ADV7181 evaluation board is now obsolete. For new evaluation and design, the ADV7181B evaluation board is recommended.

ADV7181

NOTES

NOTES

ADV7181

NOTES

Purchase of licensed I²C components of Analog Devices or one of its sublicensed Associated Companies conveys a license for the purchaser under the Philips I²C Patent Rights to use these components in an I²C system, provided that the system conforms to the I²C Standard Specification as defined by Philips.

© 2005 Analog Devices, Inc. All rights reserved. Trademarks and registered trademarks are the property of their respective owners.
D04820-0-3/05(B)



www.analog.com