

ISP1507E; ISP1507F

ULPI Hi-Speed USB On-The-Go transceiver

Rev. 04 — 20 May 2010

Product data sheet

1. General description

The ISP1507 is a Universal Serial Bus (USB) On-The-Go (OTG) transceiver that is fully compliant with *Universal Serial Bus Specification Rev. 2.0, On-The-Go Supplement to the USB 2.0 Specification Rev. 1.3* and *UTMI+ Low Pin Interface (ULPI) Specification Rev. 1.1*.

The ISP1507 can transmit and receive USB data at high-speed (480 Mbit/s), full-speed (12 Mbit/s) and low-speed (1.5 Mbit/s), and provides a pin-optimized, physical layer front-end attachment to USB host, peripheral and OTG devices.

It is ideal for use in portable electronic devices, such as mobile phones, digital still cameras, digital video cameras, Personal Digital Assistants (PDAs) and digital audio players. It allows USB Application-Specific Integrated Circuits (ASICs), Programmable Logic Devices (PLDs) and any system chip set to interface with the physical layer of the USB through an 8-pin interface.

The ISP1507 can interface to devices with digital I/O voltages in the range of 1.65 V to 1.95 V.

The ISP1507 is available in HVQFN24 package.

2. Features

- Fully complies with:
 - ◆ *Universal Serial Bus Specification Rev. 2.0*
 - ◆ *On-The-Go Supplement to the USB 2.0 Specification Rev. 1.3*
 - ◆ *UTMI+ Low Pin Interface (ULPI) Specification Rev. 1.1*
- Interfaces to host, peripheral and OTG device cores; optimized for portable devices or system ASICs with built-in USB OTG device core
- Complete Hi-Speed USB physical front-end solution that supports high-speed (480 Mbit/s), full-speed (12 Mbit/s) and low-speed (1.5 Mbit/s)
 - ◆ Integrated $45\ \Omega \pm 10\%$ high-speed termination resistors, $1.5\ \text{k}\Omega \pm 5\%$ full-speed device pull-up resistor, and $15\ \text{k}\Omega \pm 5\%$ host termination resistors
 - ◆ Integrated parallel-to-serial and serial-to-parallel converters to transmit and receive
 - ◆ USB clock and data recovery to receive USB data up to ± 500 ppm
 - ◆ Insertion of stuff bits during transmit and discarding of stuff bits during receive
 - ◆ Non-Return-to-Zero Inverted (NRZI) encoding and decoding
 - ◆ Supports bus reset, suspend, resume and high-speed detection handshake (chirp)
- Complete USB OTG physical front-end that supports Host Negotiation Protocol (HNP) and Session Request Protocol (SRP)

- ◆ Integrated 5 V charge pump; also supports external charge pump or 5 V V_{BUS} switch
- ◆ Complete control over bus resistors
- ◆ Data line and V_{BUS} pulsing session request methods
- ◆ Integrated V_{BUS} voltage comparators
- ◆ Integrated cable (ID) detector
- Highly optimized ULPI compliant
 - ◆ 60 MHz, 8-bit interface between the core and the transceiver
 - ◆ Supports 4-bit dual-edge data bus
 - ◆ Supports 60 MHz output clock configuration
 - ◆ Integrated Phase-Locked Loop (PLL), supporting one crystal or clock frequency: 19.2 MHz (ISP1507E) and 26 MHz (ISP1507F)
 - ◆ Fully programmable ULPI-compliant register set
 - ◆ Internal Power-On Reset (POR) circuit
- Flexible system integration and very low current consumption, optimized for portable devices
 - ◆ Power-supply input range is 3.0 V to 3.6 V
 - ◆ Internal voltage regulator supplies 3.3 V and 1.8 V
 - ◆ Charge pump regulator outputs 4.65 V to 5.25 V at a current of up to 50 mA, tunable using an external capacitor
 - ◆ Supports interfacing I/O voltage of 1.65 V to 1.95 V; separate I/O voltage pins minimize crosstalk
 - ◆ Typical operating current of 11 mA to 48 mA, depending on the USB speed and bus utilization; not including the charge pump
 - ◆ Typical suspend current of 30 μ A
- Full industrial grade operating temperature range from -40°C to $+85^{\circ}\text{C}$
- 4 kV ElectroStatic Discharge (ESD) protection at pins DP, DM, ID, V_{BUS} and GND
- Available in a small HVQFN24 (4 mm \times 4 mm) Restriction of Hazardous Substances (RoHS) compliant, halogen-free and lead-free package

3. Applications

- Digital still camera
- Digital TV
- Digital Video Disc (DVD) recorder
- External storage device, for example:
 - ◆ Magneto-Optical (MO) drive
 - ◆ Optical drive: CD-ROM, CD-RW, DVD
 - ◆ Zip drive
- Mobile phone
- MP3 player
- PDA
- Portable Media Player (PMP)
- Printer
- Scanner

- Set-Top Box (STB)
- Video camera

4. Ordering information

Table 1. Ordering information

Commercial product code	Marking	Crystal or clock frequency	Package description	Packing	Minimum sellable quantity
ISP1507EBSUM	07E ^[1]	19.2 MHz	HVQFN24; 24 terminals; body 4 × 4 × 0.85 mm	13 inch tape and reel dry pack	6000 pieces
ISP1507FBSUM	07F ^[1]	26 MHz	HVQFN24; 24 terminals; body 4 × 4 × 0.85 mm	13 inch tape and reel dry pack	6000 pieces

[1] The package marking is the first line of text on the IC package and can be used for IC identification.

5. Block diagram

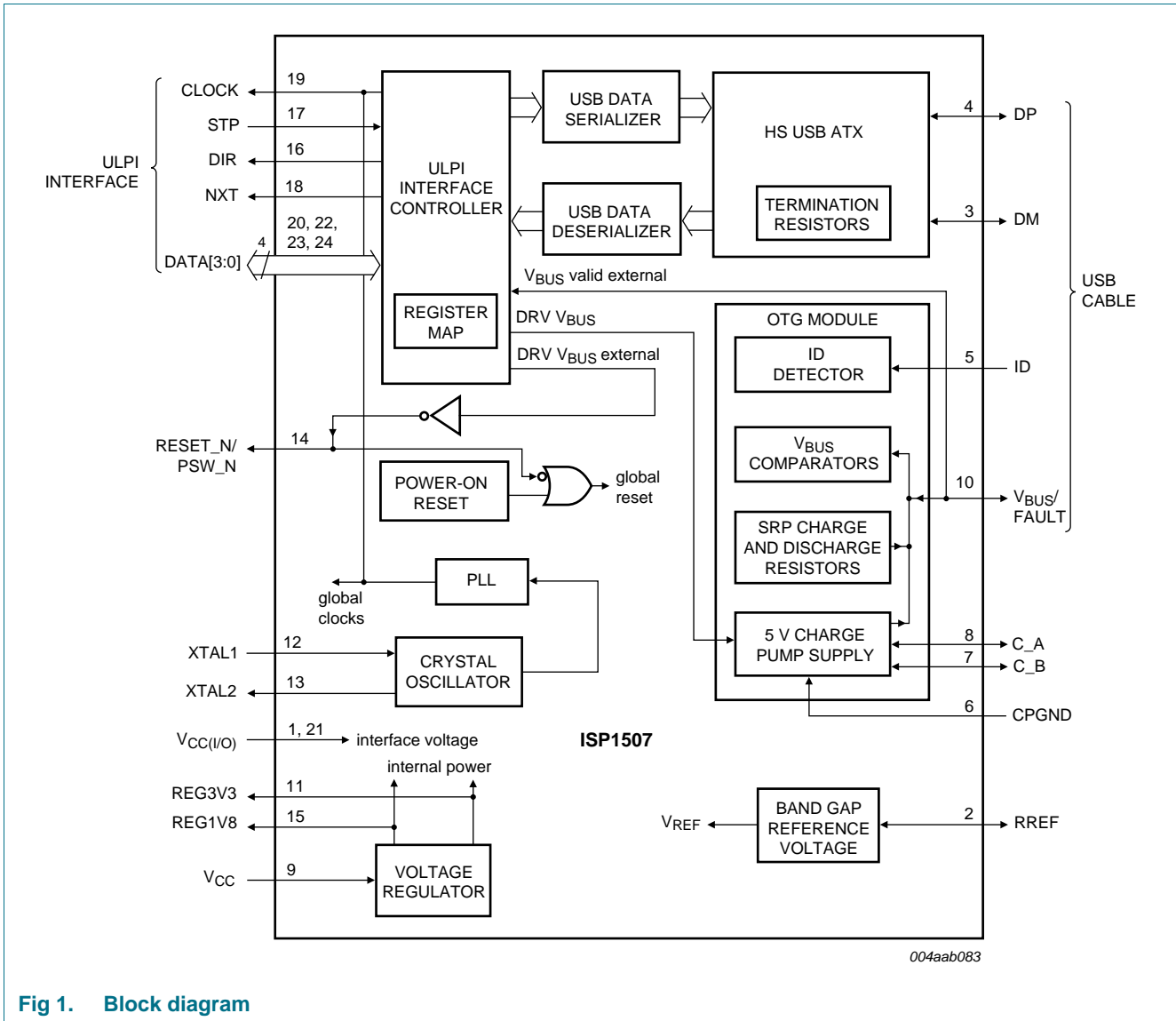

Fig 1. Block diagram

6. Pinning information

6.1 Pinning

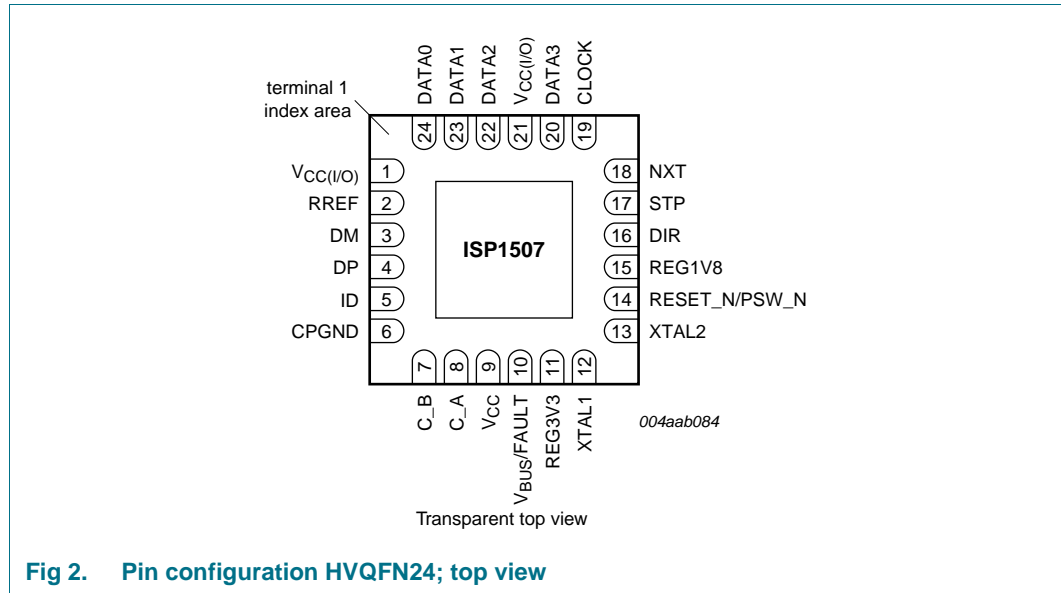

Fig 2. Pin configuration HVQFN24; top view

6.2 Pin description

Table 2. Pin description

Symbol ^{[1][2][3]}	Pin	Type ^[4]	Description
V _{CC(I/O)}	1	P	I/O supply rail
RREF	2	AI/O	resistor reference
DM	3	AI/O	data minus (D-) pin of the USB cable
DP	4	AI/O	data plus (D+) pin of the USB cable
ID	5	I	identification (ID) pin of the micro-USB cable If this pin is not used, it is recommended to connect it to REG3V3. plain input; TTL level
CPGND	6	P	charge pump ground
C_B	7	AI/O	flying capacitor pin connection for the charge pump If this pin is not in use, it must be left floating.
C_A	8	AI/O	flying capacitor pin connection for the charge pump If this pin is not in use, it must be left floating.
V _{CC}	9	P	input supply voltage or battery source
V _{BUS/FAULT}	10	AI/O	This pin has two possible functions: V_{BUS} (analog input and output) — V _{BUS} pin of the USB cable FAULT (input) — Input pin for the external V _{BUS} digital overcurrent or fault detector signal If this pin is not used as either V _{BUS} or FAULT, it must be connected to ground. plain input; 5 V tolerant
REG3V3	11	P	3.3 V regulator output; requires parallel 0.1 μF and 4.7 μF capacitors; internally powers ATX and other analog circuits; must not be used to power external circuits

Table 2. Pin description ...continued

Symbol ^{[1][2][3]}	Pin	Type ^[4]	Description
XTAL1	12	AI	crystal oscillator or clock input
XTAL2	13	AO	crystal oscillator output
RESET_N/ PSW_N	14	I/O	This pin has two possible functions: RESET_N (input) — Active LOW asynchronous reset input 3.3 V tolerant; plain input PSW_N (output) — Active LOW external V _{BUS} power switch or external charge pump enable open-drain; 3.3 V tolerant If not used, this pin must be connected to V _{CC(I/O)} .
REG1V8	15	P	1.8 V regulator output; requires parallel 0.1 μF and 4.7 μF capacitors; internally powers the digital core; must not be used to power external circuits
DIR	16	O	ULPI direction signal slew-rate controlled output (1 ns)
STP	17	I	ULPI stop signal plain input; programmable pull up
NXT	18	O	ULPI next signal slew-rate controlled output (1 ns)
CLOCK	19	O	60 MHz clock output 2 mA output drive
DATA3	20	I/O	pin 3 of the bidirectional ULPI data bus 2 mA output drive; plain input; programmable pull down
V _{CC(I/O)}	21	P	I/O supply rail
DATA2	22	I/O	pin 2 of the bidirectional ULPI data bus 2 mA output drive; plain input; programmable pull down
DATA1	23	I/O	pin 1 of the bidirectional ULPI data bus 2 mA output drive; plain input; programmable pull down
DATA0	24	I/O	pin 0 of the bidirectional ULPI data bus 2 mA output drive; plain input; programmable pull down
GND	die pad	P	ground supply; down bonded to the exposed die pad (heat sink); to be connected to the PCB ground

[1] A detailed description of these pins can be found in [Section 7.9](#).

[2] Symbol names ending with an underscore N (for example, NAME_N) indicate active LOW signals.

[3] For details on external components required on each pin, see list of materials and application diagrams in [Section 16](#).

[4] I = input; O = output; I/O = digital input/output; AI = analog input; AO = analog output; AI/O = analog input/output; P = power or ground pin.

7. Functional description

7.1 ULPI controller

The ISP1507 provides an 8-pin interface that is compliant with *UTMI+ Low Pin Interface (ULPI) Specification Rev. 1.1*. This interface must be connected to the USB link.

The ULPI controller provides the following functions:

- ULPI-compliant interface and register set
- Allows full control over the USB peripheral, host and OTG functionality
- Parses the USB transmit and receive data
- Prioritizes the USB receive data, USB transmit data, interrupts and register operations
- Control of the V_{BUS} charge pump or external source
- V_{BUS} monitoring, charging and discharging
- Low-power mode
- 3-pin serial mode
- Generates RXCMDs (status updates)
- Maskable interrupts
- Control over the ULPI bus state; can attach weak pull-down resistors to DATA[3:0]

For more information on the ULPI protocol, see [Section 9](#).

7.2 USB data serializer and deserializer

The USB data serializer prepares data to transmit on the USB bus. To transmit data, the USB link sends a transmit command and data on the ULPI bus. The serializer performs parallel-to-serial conversion, bit stuffing and NRZI encoding. For packets with a PID, the serializer adds a SYNC pattern to the start of the packet, and an EOP pattern to the end of the packet. When the serializer is busy and cannot accept any more data, the ULPI controller deasserts NXT.

The USB data deserializer decodes data received from the USB bus. When data is received, the deserializer strips the SYNC and EOP patterns, and then performs serial-to-parallel conversion, NRZI decoding and discarding of stuff bits on the data payload. The ULPI controller sends data to the USB link by asserting DIR, and then asserting NXT whenever a byte is ready. The deserializer also detects various receive errors, including bit stuff errors, elasticity buffer underrun or overrun, and byte-alignment errors.

7.3 Hi-Speed USB (USB 2.0) ATX

The Hi-Speed USB ATX block is an analog front-end containing the circuitry needed to transmit, receive and terminate the USB bus in high-speed, full-speed and low-speed, for USB peripheral, host and OTG implementations. The following circuitry is included:

- Differential drivers to transmit data at high-speed, full-speed and low-speed
- Differential and single-ended receivers to receive data at high-speed, full-speed and low-speed

- Squelch circuit to detect high-speed bus activity
- High-speed disconnect detector
- 45 Ω high-speed bus terminations on DP and DM for peripheral and host modes
- 1.5 k Ω pull-up resistor on DP for full-speed peripheral mode
- 15 k Ω bus terminations on DP and DM for host and OTG modes

For details on controlling resistor settings, see [Table 7](#).

7.4 Voltage regulator

The ISP1507 contains a built-in voltage regulator that conditions the V_{CC} supply for use inside the ISP1507. The voltage regulator:

- Supports input supply range of $3.0\text{ V} < V_{CC} < 3.6\text{ V}$
- Supplies internal circuitry with 1.8 V and 3.3 V

Remark: The REG1V8 and REG3V3 pins require external decoupling capacitors. For details, see [Section 16](#).

7.5 Crystal oscillator and PLL

The ISP1507 has a built-in crystal oscillator and a Phase-Locked Loop (PLL) for clock generation.

The crystal oscillator takes a sine-wave input from an external crystal on the XTAL1 pin, and converts it to a square wave clock for internal use. Alternatively, a square wave clock of the same frequency can also be directly driven into the XTAL1 pin. Using an existing square wave clock can save the cost of the crystal and also reduce the board size.

The PLL takes the square wave clock from the crystal oscillator, and multiplies or divides it into various frequencies for internal use.

The PLL produces the following frequencies, irrespective of the clock source:

- 60 MHz clock for the ULPI controller
- 1.5 MHz for the low-speed USB data
- 12 MHz for the full-speed USB data
- 480 MHz for the high-speed USB data
- Other internal frequencies for data conversion and data recovery

7.6 OTG module

This module contains several sub-blocks that provide all the functionality required by the USB OTG specification. Specifically, it provides the following circuits:

- The ID detector to sense the ID pin of the micro-USB cable. The ID pin dictates which device is initially configured as the host and which as the peripheral.
- V_{BUS} comparators to determine the V_{BUS} voltage level. This is required for the V_{BUS} detection, SRP and HNP.
- Resistors to temporarily charge and discharge V_{BUS} . This is required for SRP.

- Charge pump to provide 5 V power on V_{BUS} . The downstream peripheral can draw its power from the ISP1507 V_{BUS} .

7.6.1 ID detector

The ID detector detects which end of the micro-USB cable is plugged in. The detector must first be enabled by setting the ID_PULLUP register bit to logic 1. If the ISP1507 senses a value on ID that is different from the previously reported value, an RXCMD status update will be sent to the USB link, or an interrupt will be asserted.

- If the micro-B end of the cable is plugged in, the ISP1507 will report that ID_GND is logic 1. The USB link must change to peripheral mode.
- If the micro-A end of the cable is plugged in, the ISP1507 will report that ID_GND is logic 0. The USB link must change to host mode.

7.6.2 V_{BUS} comparators

The ISP1507 provides three comparators, V_{BUS} valid comparator, session valid comparator and session end comparator, to detect the V_{BUS} voltage level.

7.6.2.1 V_{BUS} valid comparator

This comparator is used by hosts and A-devices to determine whether the voltage on V_{BUS} is at a valid level for operation. The ISP1507 minimum threshold for the V_{BUS} valid comparator is 4.4 V. Any voltage on V_{BUS} below this threshold is considered invalid. During power-up, it is expected that the comparator output will be ignored.

7.6.2.2 Session valid comparator

The session valid comparator is a TTL-level input that determines when V_{BUS} is high enough for a session to start. Peripherals, A-devices and B-devices use this comparator to detect when a session is started. The A-device also uses this comparator to determine when a session is completed. The session valid threshold of the ISP1507 is $V_{B_SESS_VLD}$, with a hysteresis of $V_{hys}(B_SESS_VLD)$.

7.6.2.3 Session end comparator

The ISP1507 session end comparator determines when V_{BUS} is below the B-device session end threshold. The B-device uses this threshold to determine when a session has ended. The session end threshold of the ISP1507 is $V_{B_SESS_END}$.

7.6.3 SRP charge and discharge resistors

The ISP1507 provides on-chip resistors for short-term charging and discharging of V_{BUS} . These are used by the B-device to request a session, prompting the A-device to restore the V_{BUS} power. First, the B-device makes sure that V_{BUS} is fully discharged from the previous session by setting the DISCHRG_VBUS register bit to logic 1 and waiting for SESS_END to be logic 1. Then the B-device charges V_{BUS} by setting the CHRG_VBUS register bit to logic 1. The A-device sees that V_{BUS} is charged above the session valid threshold and starts a session by turning on the V_{BUS} power.

7.6.4 Charge pump

The ISP1507 uses a built-in charge pump to supply current to V_{BUS} at a nominal voltage of 5 V. The charge pump works as a capacitive DC-DC converter. An external holding capacitor, $C_{cp}(C_A)-(C_B)$, is required between the C_A and C_B pins as shown in [Figure 3](#),

which also shows a typical OTG V_{BUS} load. The value of $C_{cp(C_A)-(C_B)}$ depends on the amount of current drive required. If the internal charge pump is not used, the $C_{cp(C_A)-(C_B)}$ capacitor is not required.

For details on the C_A and C_B pins, see [Section 7.9.7](#).

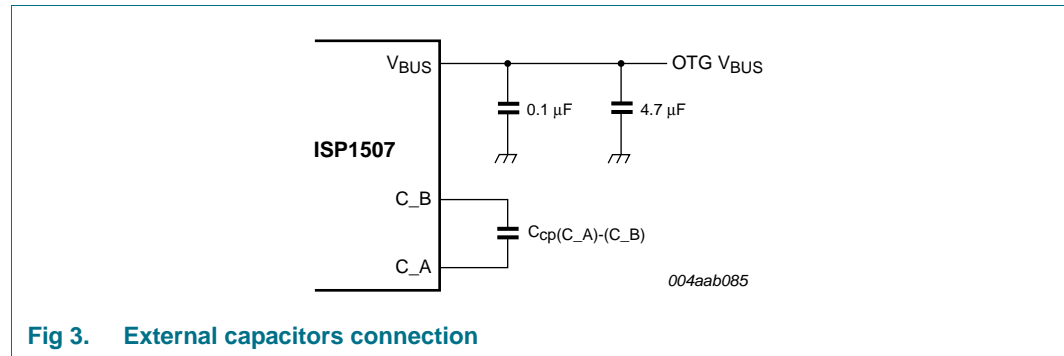

Fig 3. External capacitors connection

7.7 Band gap reference voltage

The band gap circuit provides a stable internal voltage reference to bias the analog circuitry. This band gap requires an accurate external reference resistor R_{REF} connected between the RREF and GND pins. For details, see [Section 16](#).

7.8 Power-On Reset (POR)

The ISP1507 has an internal power-on-reset circuit that resets all internal logic on power-up. The ULPI is also reset on power-up.

Remark: When CLOCK starts toggling after power-up, the USB link must issue a reset command over the ULPI bus to ensure correct operation of the ISP1507.

7.9 Detailed description of pins

7.9.1 DATA[3:0]

The ISP1507 is a Physical layer (PHY) containing a USB transceiver. DATA[3:0] is a dual-edge bidirectional data bus. The USB link must drive DATA[3:0] to LOW when the ULPI bus is idle. When the link has data to transmit to the PHY, it drives a nonzero value.

The data bus can be reconfigured to carry various data types, as given in [Section 8](#) and [Section 9](#).

7.9.2 $V_{CC(I/O)}$

The input power pin that sets the I/O voltage level. For details, see [Section 12](#), [Section 13](#) and [Section 16](#). $V_{CC(I/O)}$ provides power to on-chip pads of the following pins:

- CLOCK
- DATA[3:0]
- DIR
- NXT
- RESET_N/PSW_N

- STP

7.9.3 RREF

Resistor reference analog I/O pin. A resistor, R_{RREF} , must be connected between RREF and GND, as shown in [Section 16](#). This provides an accurate voltage reference that biases internal analog circuitry. Less accurate resistors cannot be used and will render the ISP1507 unusable.

7.9.4 DP and DM

DP (data plus) and DM (data minus) are USB differential data pins. These must be connected to the D+ and D- pins of the USB receptacle.

7.9.5 ID

For OTG implementations, the ID (identification) pin is connected to the ID pin of the micro-USB receptacle. As defined in *On-The-Go Supplement to the USB 2.0 Specification Rev. 1.3*, the ID pin dictates the initial role of the link. If ID is detected as HIGH, the link must assume the role of a peripheral. If ID is detected as LOW, the link must assume a host role. Roles can be swapped at a later time by using HNP.

If the ISP1507 is not used as an OTG PHY, but as a standard USB host or peripheral PHY, the ID pin must be connected to REG3V3.

7.9.6 CPGND

CPGND indicates the analog ground for the on-board charge pump. CPGND must always be connected to ground, even when the charge pump is not used.

7.9.7 C_A and C_B

The C_A and C_B pins are to connect the flying capacitor of the charge pump. The output current capability of the charge pump depends on the value of the capacitor used, as shown in [Table 3](#). For maximum efficiency, place capacitors as close as possible to pins. For details, see [Section 16](#).

If the charge pump is not used, C_A and C_B must be left floating (not connected).

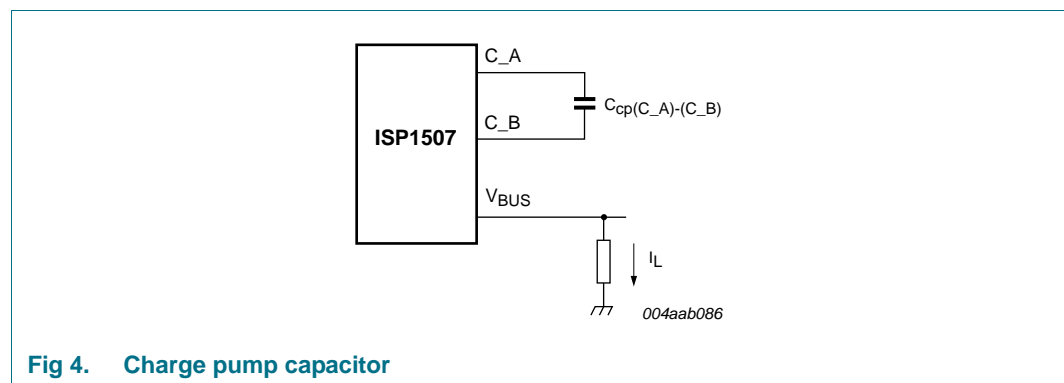

Fig 4. Charge pump capacitor

Table 3. Recommended charge pump capacitor value

$C_{cp(C_A)-(C_B)}$	I_L (max)
22 nF	8 mA
270 nF	50 mA

7.9.8 V_{CC}

V_{CC} is the main input supply voltage for the ISP1507. Decoupling capacitors are recommended. For details, see [Section 16](#).

7.9.9 $V_{BUS}/FAULT$

This pin provides two options for V_{BUS} driving and monitoring. If neither function is used, this pin must be connected to ground.

7.9.9.1 V_{BUS}

This pin acts as an input to V_{BUS} comparators, and also as a power pin for the charge pump, and SRP charge and discharge resistors.

The V_{BUS} pin requires a capacitive load as shown in [Section 16](#).

To prevent electrical overstress, it is strongly recommended that you attach a series resistor on the V_{BUS} pin (R_{VBUS}). R_{VBUS} must not be attached when using the ISP1507 internal charge pump. For details, see [Section 16](#).

7.9.9.2 FAULT (external overcurrent or fault detector)

If an external V_{BUS} overcurrent or fault circuit is used, the output fault indicator of that circuit can be connected to the ISP1507 FAULT input pin. The ISP1507 will inform the link of V_{BUS} fault events by sending RXCMDs on the ULPI bus. To use the FAULT pin, the link must:

- Set the USE_EXT_VBUS_IND register bit to logic 1.
- Set the polarity of the external fault signal using the IND_COMPL register bit.

7.9.10 REG3V3 and REG1V8

Regulator output voltage. These supplies are used to power the ISP1507 internal digital and analog circuits, and must not be used to power external circuits.

For correct operation of the regulator, it is recommended that you connect REG3V3 and REG1V8 to decoupling capacitors. For examples, see [Section 16](#).

7.9.11 XTAL1 and XTAL2

XTAL1 is the crystal input, and XTAL2 is the crystal output. The allowed frequency on the XTAL1 pin depends on the ISP1507 product version.

The ISP1507 requires external load capacitors to GND on each terminal of the crystal. For details, see [Section 16](#).

If at any time the system wants to stop the clock on XTAL1, the link must first put the ISP1507 into low-power mode. The clock on XTAL1 must be restarted before low-power mode is exited.

7.9.12 RESET_N/PSW_N

This pin provides two optional functions. If neither function is used, this pin must be connected to $V_{CC(I/O)}$.

7.9.12.1 RESET_N

An active LOW asynchronous reset pin that resets all circuits in the ISP1507. The ISP1507 contains an internal power-on reset circuit, and therefore using the RESET_N pin is optional. If RESET_N is not used, it must be connected to $V_{CC(I/O)}$.

For details on using RESET_N, see [Section 9.3.2](#).

7.9.12.2 PSW_N

PSW_N is an active LOW, open-drain output pin. This pin can be connected to an active LOW, external V_{BUS} switch or charge pump enable circuit to control the external V_{BUS} power source. An external pull-up resistor, R_{pullup} , is required when PSW_N is used. This pin is open-drain, allowing ganged-mode power control for multiple USB ports. For application details, see [Section 16](#).

To use the PSW_N pin, the link must disable the reset input by setting the IGNORE_RESET bit in the PWR_CTRL register (see [Section 10.1.14](#)) to logic 1. This will ensure that PSW_N is not misinterpreted as a reset.

If the link is in host mode, it can enable the external V_{BUS} power source by setting the DRV_VBUS_EXT bit in the OTG_CTRL register (see [Section 10.1.4](#)) to logic 1. The ISP1507 will drive PSW_N to LOW to enable the external V_{BUS} power source. If the link detects an overcurrent condition (the V_{BUS} state in RXCMD is not 11b), it must disable the external V_{BUS} supply by setting DRV_VBUS_EXT to logic 0.

7.9.13 DIR

ULPI direction output pin. Controls the direction of the data bus. By default, the ISP1507 holds DIR at LOW, causing the data bus to be an input. When DIR is LOW, the ISP1507 listens for data from the link. The ISP1507 pulls DIR to HIGH only when it has data to send to the link, which is for one of two reasons:

- To send the USB receive data, RXCMD status updates and register reads data to the link.
- To block the link from driving the data bus during power-up, reset and low-power mode (suspend).

For details on DIR usage, refer to *UTMI+ Low Pin Interface (ULPI) Specification Rev. 1.1*.

7.9.14 STP

ULPI stop input pin. The link must assert STP to signal the end of a USB transmit packet or a register write operation. When DIR is asserted, the link can optionally assert STP to abort the ISP1507, causing it to deassert DIR in the next clock cycle. A weak pull-up resistor is incorporated into the STP pin as part of the interface protect feature. For details, see [Section 9.3.1](#).

For details on STP usage, refer to *UTMI+ Low Pin Interface (ULPI) Specification Rev. 1.1*.

7.9.15 NXT

ULPI next data output pin. The ISP1507 holds NXT at LOW by default. When DIR is LOW and the link is sending data to the ISP1507, NXT will be asserted to notify the link to provide the next data byte. When DIR is at HIGH and the ISP1507 is sending data to the link, NXT will be asserted to notify the link that another valid byte is on the bus. NXT is not used for register read data or the RXCMD status update.

For details on NXT usage, refer to *UTMI+ Low Pin Interface (ULPI) Specification Rev. 1.1*.

7.9.16 CLOCK

A 60 MHz output interface clock to synchronize the ULPI bus. The ISP1507 provides two clocking options:

- A crystal is attached between the XTAL1 and XTAL2 pins.
- A clock is driven into the XTAL1 pin, with the XTAL2 pin left floating.

For details on CLOCK usage, refer to *UTMI+ Low Pin Interface (ULPI) Specification Rev. 1.1*.

7.9.17 GND (die pad)

Global ground signal, except for the charge pump that uses CPGND. The die pad is exposed on the underside of the package as a ground plate. This acts as a ground to all circuits in the ISP1507, except the charge pump. To ensure correct operation of the ISP1507, GND must be soldered to the cleanest ground available.

8. Modes of operation

8.1 ULPI modes

The ISP1507 ULPI bus can be programmed to operate in three modes. Each mode reconfigures the signals on the data bus as described in the following subsections. Setting more than one mode will lead to undefined behavior.

8.1.1 Synchronous mode

This is default mode. At power-up, and when CLOCK is stable, the ISP1507 will enter synchronous mode. The link must synchronize all ULPI signals to CLOCK, meeting the set-up and hold times as defined in [Section 15](#). A description of the ULPI pin behavior in synchronous mode is given in [Table 4](#).

This mode is used by the link to perform the following tasks:

- High-speed detection handshake (chirp)
- Transmit and receive USB packets
- Read and write to registers
- Receive USB status updates (RXCMDs)

For more information on the various synchronous mode protocols, see [Section 9](#).

Table 4. ULPI signal description

Signal name	Direction on ISP1507	Signal description
CLOCK	I/O	60 MHz interface clock. If a crystal is attached or a clock is driven into the XTAL1 pin, the ISP1507 will drive a 60 MHz output clock.
DATA[3:0]	I/O	4-bit data bus. In synchronous mode, the link drives DATA[3:0] to LOW by default. The link initiates transfers by sending a nonzero data pattern called TXCMD (transmit command). In synchronous mode, the direction of DATA[3:0] is controlled by DIR. Contents of DATA[3:0] lines must be ignored for exactly one clock cycle whenever DIR changes value. This is called the turnaround cycle. Bytes of data are transferred between the link and PHY in 4-bit nibbles. The least significant nibble, DATA[3:0], is transferred first on the rising edge of clock. The most significant nibble, DATA[7:4], is transferred next on the falling edge of clock. Transferring an odd number of 4-bit nibbles is not allowed. Data lines have fixed direction and different meaning in low-power and 3-pin serial modes.

Table 4. ULPI signal description ...continued

Signal name	Direction on ISP1507	Signal description
DIR	O	<p>Direction: Controls the direction of data bus DATA[3:0]. In synchronous mode, the ISP1507 drives DIR to LOW by default, making the data bus an input so that the ISP1507 can listen for TXCMDs from the link. The ISP1507 drives DIR to HIGH only when it has data for the link. When DIR and NXT are HIGH, the byte on the data bus contains decoded USB data. When DIR is HIGH and NXT is LOW, the byte contains status information called RXCMD (receive command). The only exception to this rule is when the PHY returns register read data, where NXT is also LOW, replacing the usual RXCMD byte. Every change in DIR causes a turnaround cycle on the data bus, during which DATA[3:0] is not valid and must be ignored by the link.</p> <p>DIR is always asserted during low-power and 3-pin serial modes.</p>
STP	I	<p>Stop: In synchronous mode, the link drives STP to HIGH for one cycle after the last byte of data is sent to the ISP1507. The link can optionally assert STP to force DIR to be deasserted.</p> <p>In low-power and 3-pin serial modes, the link holds STP at HIGH to wake up the ISP1507, causing the ULPI bus to return to synchronous mode.</p>
NXT	O	<p>Next: In synchronous mode, the ISP1507 drives NXT to HIGH to throttle data. If DIR is LOW, the ISP1507 asserts NXT to notify the link to place the next data byte on DATA[3:0] in the following clock cycle. If DIR is HIGH, the ISP1507 asserts NXT to notify the link that a valid USB data byte is on DATA[3:0] in the current cycle. The ISP1507 always drives an RXCMD when DIR is HIGH and NXT is LOW, unless register read data is to be returned to the link in the current cycle.</p> <p>NXT is not used in low-power or 3-pin serial modes.</p>

8.1.2 Low-power mode

When the USB is idle, the link can place the ISP1507 into low-power mode (also called suspend mode). In low-power mode, the data bus definition changes to that shown in [Table 5](#). To enter low-power mode, the link sets the SUSPENDM bit in the FUNC_CTRL register (see [Section 10.1.2](#)) to logic 0. To exit low-power mode, the link asserts the STP signal. The ISP1507 will draw only suspend current from the V_{CC} supply (see [Table 45](#)).

During low-power mode, the clock on XTAL1 may be stopped. The clock must be started again before asserting STP to exit low-power mode. After exiting low-power mode, the ISP1507 will send an RXCMD to the link if a change was detected in any interrupt source, and the change still exists. An RXCMD may not be sent if the interrupt condition is removed before exiting.

For more information on low-power mode enter and exit protocols, refer to *UTMI+ Low Pin Interface (ULPI) Specification Rev. 1.1*.

Table 5. Signal mapping during low-power mode

Signal	Maps to	Direction	Description
LINESTATE0	DATA0	O	combinatorial LINESTATE0 directly driven by the analog receiver
LINESTATE1	DATA1	O	combinatorial LINESTATE1 directly driven by the analog receiver
Reserved	DATA2	O	reserved; the ISP1507 will drive this pin to LOW
INT	DATA3	O	active HIGH interrupt indication; will be asserted whenever any unmasked interrupt occurs

8.1.3 3-pin full-speed or low-speed serial mode

If the link requires a 3-pin serial interface to transmit and receive full-speed or low-speed USB data, it can set the ISP1507 to 3-pin serial mode. In 3-pin serial mode, the data bus definition changes to that shown in [Table 6](#). To enter 3-pin serial mode, the link sets the 3PIN_FSLS_SERIAL bit in the INTF_CTRL register (see [Section 10.1.3](#)) to logic 1. To exit 3-pin serial mode, the link asserts STP. This is primarily provided for links that contain legacy full-speed or low-speed functionality, providing a more cost-effective upgrade path to high-speed. An interrupt pin is also provided to inform the link of USB events. If the link requires CLOCK to be running during 3-pin serial mode, the CLOCK_SUSPENDM register bit must be set to logic 1.

For more information on 3-pin serial mode enter and exit protocols, refer to *UTMI+ Low Pin Interface (ULPI) Specification Rev. 1.1*.

Table 6. Signal mapping for 3-pin serial mode

Signal	Maps to	Direction	Description
TX_ENABLE	DATA0	I	active HIGH transmit enable
DAT	DATA1	I/O	transmit differential data on DP and DM when TX_ENABLE is HIGH receive differential data from DP and DM when TX_ENABLE is LOW
SE0	DATA2	I/O	transmit single-ended zero on DP and DM when TX_ENABLE is HIGH receive single-ended zero from DP and DM when TX_ENABLE is LOW
INT	DATA3	O	active HIGH interrupt indication; will be asserted whenever any unmasked interrupt occurs

8.2 USB and OTG state transitions

A Hi-Speed USB peripheral, host or OTG device handles more than one electrical state as defined in *Universal Serial Bus Specification Rev. 2.0* and *On-The-Go Supplement to the USB 2.0 Specification Rev. 1.3*. The ISP1507 accommodates various states through register bit settings of XCVRSELECT[1:0], TERMSELECT, OPMODE[1:0], DP_PULLDOWN and DM_PULLDOWN.

[Table 7](#) summarizes operating states. The values of register settings in [Table 7](#) will force resistor settings as also given in [Table 7](#). Resistor setting signals are defined as follows:

- RPU_DP_EN enables the 1.5 k Ω pull-up resistor on DP
- RPD_DP_EN enables the 15 k Ω pull-down resistor on DP
- RPD_DM_EN enables the 15 k Ω pull-down resistor on DM
- HSTERM_EN enables the 45 Ω termination resistors on DP and DM

The link is responsible for setting the desired USB and OTG states.

Table 7. Operating states and their corresponding resistor settings

Signaling mode	Register settings					Internal resistor settings			
	XCVR SELECT [1:0]	TERM SELECT	OPMODE [1:0]	DP_PULL DOWN	DM_PULL DOWN	RPU_DP_EN	RPD_DP_EN	RPD_DM_EN	HSTERM_EN
General settings									
3-state drivers	XXb	Xb	01b	Xb	Xb	0b	0b	0b	0b
Power-up or $V_{BUS} < V_{B_SESS_END}$	01b	0b	00b	1b	1b	0b	1b	1b	0b
Host settings									
Host chirp	00b	0b	10b	1b	1b	0b	1b	1b	1b
Host high-speed	00b	0b	00b	1b	1b	0b	1b	1b	1b
Host full-speed	X1b	1b	00b	1b	1b	0b	1b	1b	0b
Host high-speed or full-speed suspend	01b	1b	00b	1b	1b	0b	1b	1b	0b
Host high-speed or full-speed resume	01b	1b	10b	1b	1b	0b	1b	1b	0b
Host low-speed	10b	1b	00b	1b	1b	0b	1b	1b	0b
Host low-speed suspend	10b	1b	00b	1b	1b	0b	1b	1b	0b
Host low-speed resume	10b	1b	10b	1b	1b	0b	1b	1b	0b
Host Test J or Test K	00b	0b	10b	1b	1b	0b	1b	1b	1b
Peripheral settings									
Peripheral chirp	00b	1b	10b	0b	0b	1b	0b	0b	0b
Peripheral high-speed	00b	0b	00b	0b	0b	0b	0b	0b	1b
Peripheral full-speed	01b	1b	00b	0b	0b	1b	0b	0b	0b
Peripheral high-speed or full-speed suspend	01b	1b	00b	0b	0b	1b	0b	0b	0b
Peripheral high-speed or full-speed resume	01b	1b	10b	0b	0b	1b	0b	0b	0b
Peripheral Test J or Test K	00b	0b	10b	0b	0b	0b	0b	0b	1b
OTG settings									
OTG device peripheral chirp	00b	1b	10b	0b	1b	1b	0b	1b	0b
OTG device peripheral high-speed	00b	0b	00b	0b	1b	0b	0b	1b	1b
OTG device peripheral full-speed	01b	1b	00b	0b	1b	1b	0b	1b	0b

Table 7. Operating states and their corresponding resistor settings ...continued

Signaling mode	Register settings					Internal resistor settings			
	XCVR SELECT [1:0]	TERM SELECT	OPMODE [1:0]	DP_PULL DOWN	DM_PULL DOWN	RPU_DP_EN	RPD_DP_EN	RPD_DM_EN	HSTERM_EN
OTG device peripheral high-speed and full-speed suspend	01b	1b	00b	0b	1b	1b	0b	1b	0b
OTG device peripheral high-speed and full-speed resume	01b	1b	10b	0b	1b	1b	0b	1b	0b
OTG device peripheral Test J or Test K	00b	0b	10b	0b	1b	0b	0b	1b	1b

9. Protocol description

The following subsections describe the protocol for using the ISP1507.

Remark: In all figures, the ULPI data is shown in a generic form and not as nibbles on the rising and falling edges of the clock.

9.1 ULPI references

The ISP1507 provides an 8-pin ULPI to communicate with the link. It is highly recommended that you read *UTMI+ Low Pin Interface (ULPI) Specification Rev. 1.1* and *UTMI+ Specification Rev. 1.0*.

9.2 Power-On Reset (POR)

An internal POR is generated when REG1V8 rises above $V_{POR(trip)}$, for at least $t_{w(REG1V8_H)}$. The internal POR pulse will also be generated whenever REG1V8 drops below $V_{POR(trip)}$ for more than $t_{w(REG1V8_L)}$, and then rises above $V_{POR(trip)}$ again. The voltage on REG1V8 is generated from V_{CC} .

To give a better view of the functionality, [Figure 5](#) shows a possible curve of REG1V8. The internal POR starts with logic 0 at t_0 . At t_1 , the detector will see the passing of the trip level so that POR turns to logic 1 and a delay element will add another t_{PORP} before it drops to logic 0. If REG1V8 dips from t_2 to t_3 for $> t_{w(REG1V8_L)}$, another POR pulse is generated. If the dip at t_4 to t_5 is too short, that is, $< t_{w(REG1V8_L)}$, the internal POR pulse will not react and will remain LOW.

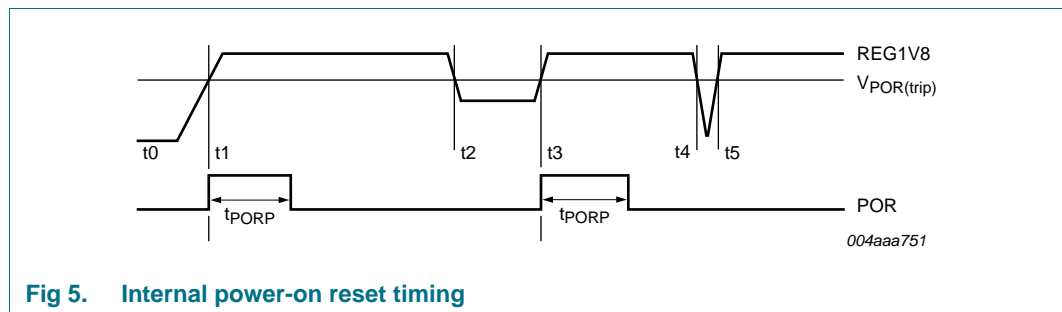

Fig 5. Internal power-on reset timing

9.3 Power-up, reset and bus idle sequence

[Figure 6](#) shows a typical start-up sequence.

On power-up, the ISP1507 performs an internal power-on reset and asserts DIR to indicate to the link that the ULPI bus cannot be used. When the internal PLL is stable, the ISP1507 deasserts DIR. The power-up time depends on the V_{CC} supply rise time, the crystal start-up time, and PLL start-up time $t_{startup(o)(CLOCK)}$. Whenever DIR is asserted, the ISP1507 drives the NXT pin to LOW and drives DATA[3:0] with RXCMD values. When DIR is deasserted, the link must drive the data bus to a valid level. By default, the link must drive data to LOW. When the ISP1507 initially deasserts DIR on power-up, the link must ignore all RXCMDs until it resets the ISP1507. Before beginning USB packets, the link must set the RESET bit in the FUNC_CTRL register (see [Section 10.1.2](#)) to reset the ISP1507. After the RESET bit is set, the ISP1507 will assert DIR until the internal reset completes. The ISP1507 will automatically deassert DIR and clear the RESET bit when

reset has completed. After every reset, an RXCMD is sent to the link to update USB status information. After this sequence, the ULPI bus is ready for use and the link can start USB operations.

When the internal PLL is stable, the ISP1507 will drive a 60 MHz clock out from the CLOCK pin when DIR deasserts. An example start-up sequence is shown in [Figure 6](#).

The recommended power-up sequence for the link is as follows:

1. The link waits for t_{REGUP} , ignoring all the ULPI pin status.
2. The link may start to detect the DIR status level. If DIR is detected as LOW for three clock cycles, the link may send a RESET command.

The ULPI is ready for use.

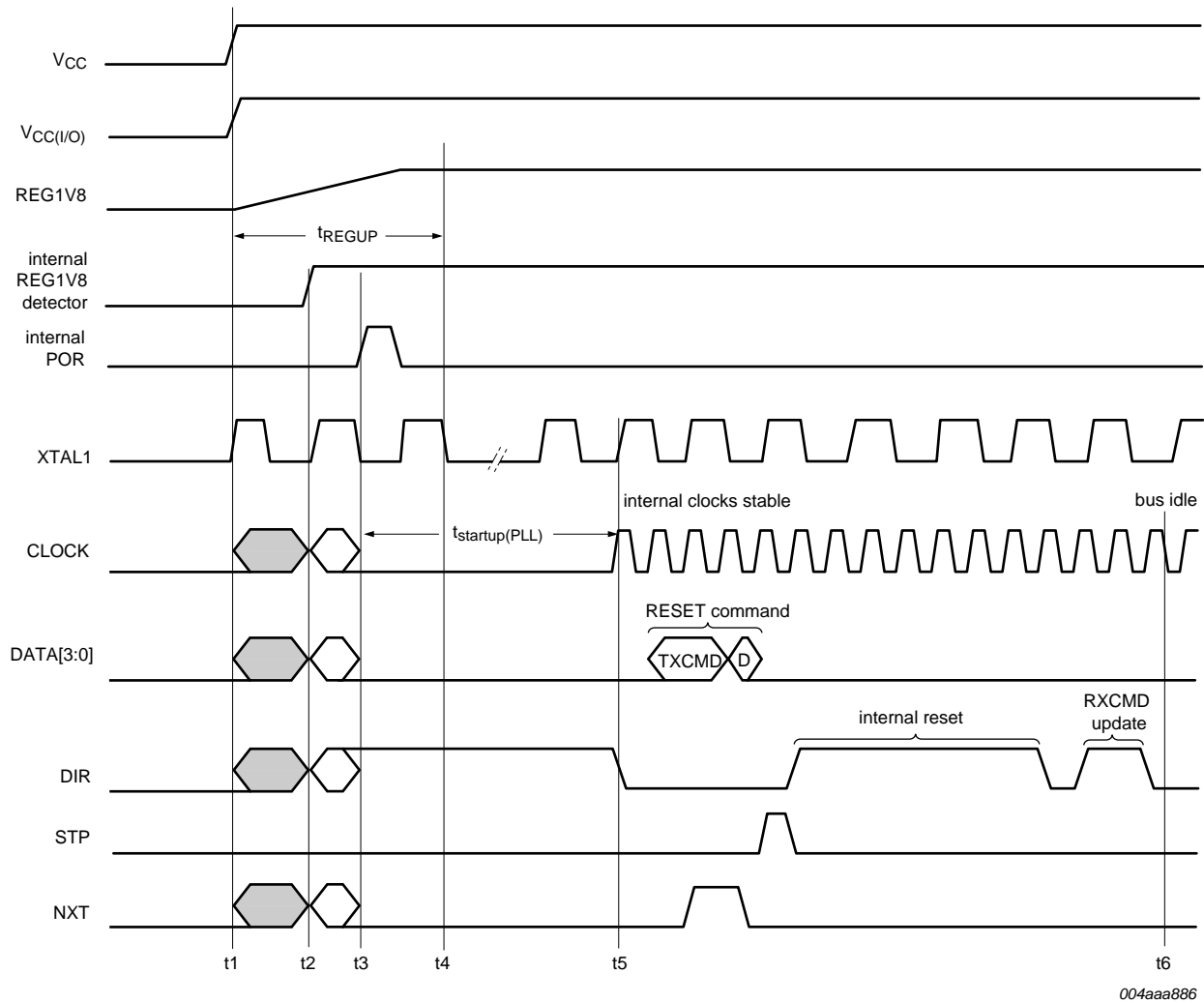

t1 = V_{CC} and $V_{CC(I/O)}$ are applied to the ISP1507. The ISP1507 regulator starts to turn on.

t2 = ULPI pads detect REG1V8 rising above the REG1V8 regulator threshold and are not in 3-state. These pads may drive either LOW or HIGH. It is recommended that the link ignores the ULPI pins status during t_{REGUP} .

t3 = The POR threshold is reached and a POR pulse is generated. After the POR pulse, ULPI pins are driven to a defined level. DIR is driven to HIGH and the other pins are driven to LOW.

t4 = The ISP1507 regulator is powered up and is stable.

t5 = The internal PLL is stabilized after $t_{startup(PLL)}$. If the 19.2 MHz or 26 MHz clock is started before POR, the internal PLL will be stabilized after $t_{startup(PLL)}$ from POR. The CLOCK pin starts to output 60 MHz. The DIR pin will transition from HIGH to LOW. The DIR pin will remain LOW before the link issues a RESET command to the ISP1507.

t6 = The power-up sequence is completed, and the ULPI bus is ready for use.

004aaa886

Fig 6. Power-up and reset sequence required before the ULPI bus is ready for use

9.3.1 Interface protection

By default, the ISP1507 enables a weak pull-up resistor on STP. If the STP pin is unexpectedly HIGH at any time, the ISP1507 will protect the ULPI by enabling weak pull-down resistors on DATA[3:0].

The interface protect feature prevents unwanted activity of the ISP1507 whenever the ULPI is not correctly driven by the link. For example, when the link powers up more slowly than the ISP1507.

The interface protect feature can be disabled by setting the INTF_PROT_DIS bit to logic 1.

9.3.2 Interface behavior with respect to RESET_N

The use of the RESET_N pin is optional. When RESET_N is asserted (LOW), the ISP1507 will assert DIR. All logic in the ISP1507 will be reset, including the analog circuitry and ULPI registers. During reset, the link must drive DATA[3:0] and STP to LOW; otherwise undefined behavior may result. When RESET_N is deasserted (HIGH), the DIR output will deassert (LOW) four or five clock cycles later. [Figure 7](#) shows the ULPI behavior when RESET_N is asserted (LOW), and subsequently deasserted (HIGH). If RESET_N is not used, it must be connected to $V_{CC(I/O)}$.

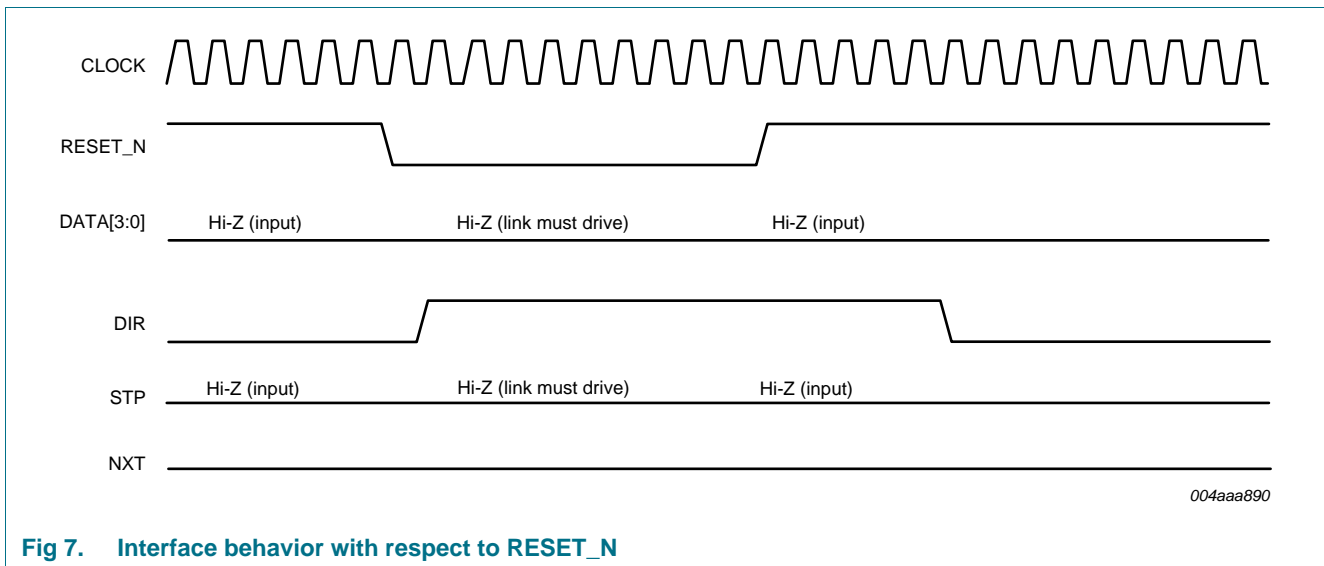

Fig 7. Interface behavior with respect to RESET_N

9.4 V_{BUS} power and fault detection

9.4.1 Driving 5 V on V_{BUS}

The ISP1507 provides a built-in charge pump. To enable the charge pump, the link must set the DRV_VBUS bit in the OTG_CTRL register (see [Section 10.1.4](#)).

The ISP1507 also supports external 5 V supplies. The ISP1507 can control the external supply using the active-LOW PSW_N open-drain output pin. To enable the external supply by driving PSW_N to LOW, the link must set the DRV_VBUS_EXT bit in the OTG_CTRL register to logic 1. The link can optionally set both the DRV_VBUS and DRV_VBUS_EXT bits to logic 1 to enable the external supply.

[Table 8](#) summarizes settings to drive 5 V on V_{BUS} .

Table 8. OTG_CTRL register power control bits

DRV_VBUS	DRV_VBUS_EXT	Power source used
0	0	internal and external V _{BUS} power sources are disabled
1	0	internal V _{BUS} charge pump is enabled
X	1	external 5 V V _{BUS} supply is enabled

9.4.2 Fault detection

The ISP1507 supports external V_{BUS} fault detector circuits that output a digital fault indicator signal. The indicator signal must be connected to the FAULT pin. To enable the ISP1507 to monitor the digital fault input, the link must set the USE_EXT_VBUS_IND bit in the OTG_CTRL register (see [Section 10.1.4](#)) and the IND_PASSTHRU bit in the INTF_CTRL register (see [Section 10.1.3](#)) to logic 1. For details, see [Figure 9](#).

The FAULT input pin is mapped to the A_VBUS_VLD bit in RXCMD. Any changes for the FAULT input will trigger RXCMD carrying the FAULT condition with A_VBUS_VLD.

9.5 TXCMD and RXCMD

Commands between the ISP1507 and the link are described in the following subsections.

9.5.1 TXCMD

By default, the link must drive the ULPI bus to its idle state of 00h. To send commands and USB packets, the link drives a nonzero value on DATA[3:0] to the ISP1507 by sending a byte called TXCMD. Commands include USB packet transmissions, and register reads and writes. Once the TXCMD is interpreted and accepted by the ISP1507, the NXT signal is asserted and the link can follow up with the required number of data bytes. The TXCMD byte format is given in [Table 9](#). Any values other than those in [Table 9](#) are illegal and will result in undefined behavior.

Various TXCMD packet and register sequences are shown in later sections.

Table 9. TXCMD byte format

Command type name	Command code	Command payload	Command name	Command description
Idle	00b	00 0000b	NOOP	No operation. 00h is the idle value of the data bus. The link must drive NOOP by default.
Packet transmit	01b	00 0000b	NOPID	Transmit USB data that does not have a PID, such as chirp and resume signaling. The ISP1507 starts transmitting only after accepting the next data byte.
		00 XXXXb	PID	Transmit USB packet. DATA[3:0] indicates USB packet identifier PID[3:0].
Register write	10b	10 1111b	EXTW	Extended register write command (optional). The 8-bit address must be provided after the command is accepted.
		XX XXXXb	REGW	Register write command with 6-bit immediate address.
Register read	11b	10 1111b	EXTR	Extended register read command (optional). The 8-bit address must be provided after the command is accepted.
		XX XXXXb	REGR	Register read command with 6-bit immediate address.

9.5.2 RXCMD

The ISP1507 communicates status information to the link by asserting DIR and sending an RXCMD byte on the data bus. The RXCMD data byte format is given in [Table 10](#).

The ISP1507 will automatically send an RXCMD whenever there is a change in any of the RXCMD data fields. The link must be able to accept an RXCMD at any time; including single RXCMDs, back-to-back RXCMDs, and RXCMDs at any time during USB receive packets when NXT is LOW. An example is shown in [Figure 8](#). For details and diagrams, refer to *UTMI+ Low Pin Interface (ULPI) Specification Rev. 1.1*.

An RXCMD may not be sent when exiting low-power mode or serial mode, if the interrupt condition is removed before exiting.

Table 10. RXCMD byte format

DATA	Name	Description and value
1 to 0	LINESTATE	LINESTATE signals: For a definition of LINESTATE, see Section 9.5.2.1 . DATA0 — LINESTATE[0] DATA1 — LINESTATE[1]
3 to 2	V _{BUS} state	Encoded V_{BUS} voltage state: For an explanation of the V _{BUS} state, see Section 9.5.2.2 .
5 to 4	RxEvent	Encoded USB event signals: For an explanation of RxEvent, see Section 9.5.2.4 .
6	ID	Set to the value of the ID pin.
7	ALT_INT	By default, this signal is not used and is not needed in typical designs. Optionally, the link can enable the BVALID_RISE and/or BVALID_FALL bits in the PWR_CTRL register. Corresponding changes in BVALID will cause an RXCMD to be sent to the link with the ALT_INT bit asserted.

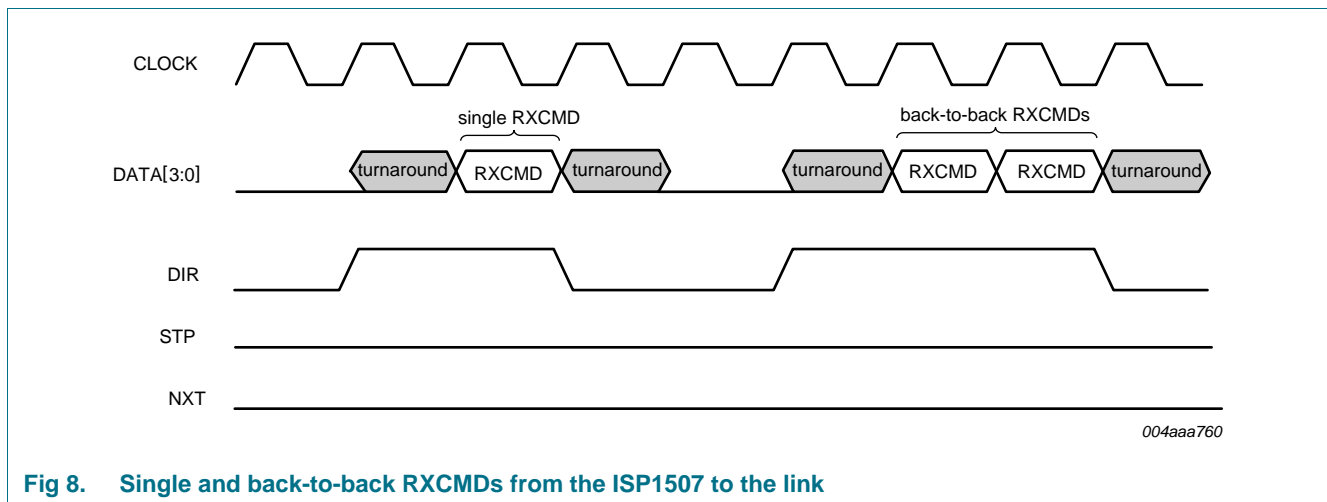

Fig 8. Single and back-to-back RXCMDs from the ISP1507 to the link

9.5.2.1 Linestate encoding

LINESTATE[1:0] reflects the current state of DP and DM. Whenever the ISP1507 detects a change in DP or DM, an RXCMD will be sent to the link with the new LINESTATE[1:0] value. The value given on LINESTATE[1:0] depends on the setting of various registers.

[Table 11](#) shows the LINESTATE[1:0] encoding for upstream facing ports, which applies to peripherals. [Table 12](#) shows the LINESTATE[1:0] encoding for downstream facing ports, which applies to host controllers. Dual-role devices must choose the correct table, depending on whether it is in peripheral or host mode.

Table 11. LINESTATE[1:0] encoding for upstream facing ports: peripheral
DP_PULLDOWN = 0.[\[1\]](#)

Mode	Full-speed	High-speed	Chirp
XCVRSELECT[1:0]	01, 11	00	00
TERMSELECT	1	0	1
LINESTATE[1:0]	00 SE0	squelch	squelch
	01 FS-J	!squelch	!squelch and HS_Differential_Receiver_Output
	10 FS-K	invalid	!squelch and !HS_Differential_Receiver_Output
	11 SE1	invalid	invalid

[1] !squelch indicates inactive squelch. !HS_Differential_Receiver_Output indicates inactive HS_Differential_Receiver_Output.

Table 12. LINESTATE[1:0] encoding for downstream facing ports: host
DP_PULLDOWN and DM_PULLDOWN = 1.[\[1\]](#)

Mode	Low-speed	Full-speed	High-speed	Chirp
XCVRSELECT[1:0]	10	01, 11	00	00
TERMSELECT	1	1	0	0
OPMODE[1:0]	X	X	00, 01 or 11	10
LINESTATE[1:0]	00 SE0	SE0	squelch	squelch
	01 LS-K	FS-J	!squelch	!squelch and HS_Differential_Receiver_Output
	10 LS-J	FS-K	invalid	!squelch and !HS_Differential_Receiver_Output
	11 SE1	SE1	invalid	invalid

[1] !squelch indicates inactive squelch. !HS_Differential_Receiver_Output indicates inactive HS_Differential_Receiver_Output.

9.5.2.2 V_{BUS} state encoding

USB devices must monitor the V_{BUS} voltage for purposes such as overcurrent detection, starting a session and SRP. The V_{BUS} state field in the RXCMD is an encoding of the voltage level on V_{BUS}.

The A_VBUS_VLD, SESS_VLD and SESS_END indicators in the V_{BUS} state are directly taken from internal comparators built-in to the ISP1507, and encoded as shown in [Table 10](#) and [Table 13](#).

Table 13. Encoded V_{BUS} voltage state

Value	V _{BUS} voltage	SESS_END	SESS_VLD	A_VBUS_VLD
00	V _{BUS} < V _{B_SESS_END}	1	0	0
01	V _{B_SESS_END} ≤ V _{BUS} < V _{B_SESS_VLD}	0	0	0
10	V _{B_SESS_VLD} ≤ V _{BUS} < V _{A_VBUS_VLD}	X	1	0
11	V _{BUS} ≥ V _{A_VBUS_VLD}	X	X	1

For high-power USB hosts supplying more than 100 mA, it is recommended that you use an external FAULT indicator. Internal comparators must not be used.

Note that V_{BUS} and FAULT share the same pin and cannot be used simultaneously. A_VBUS_VLD and FAULT will be interpreted by the ISP1507 as shown in [Figure 9](#).

A description on how to use and select the V_{BUS} state encoding is given in [Section 9.5.2.3](#).

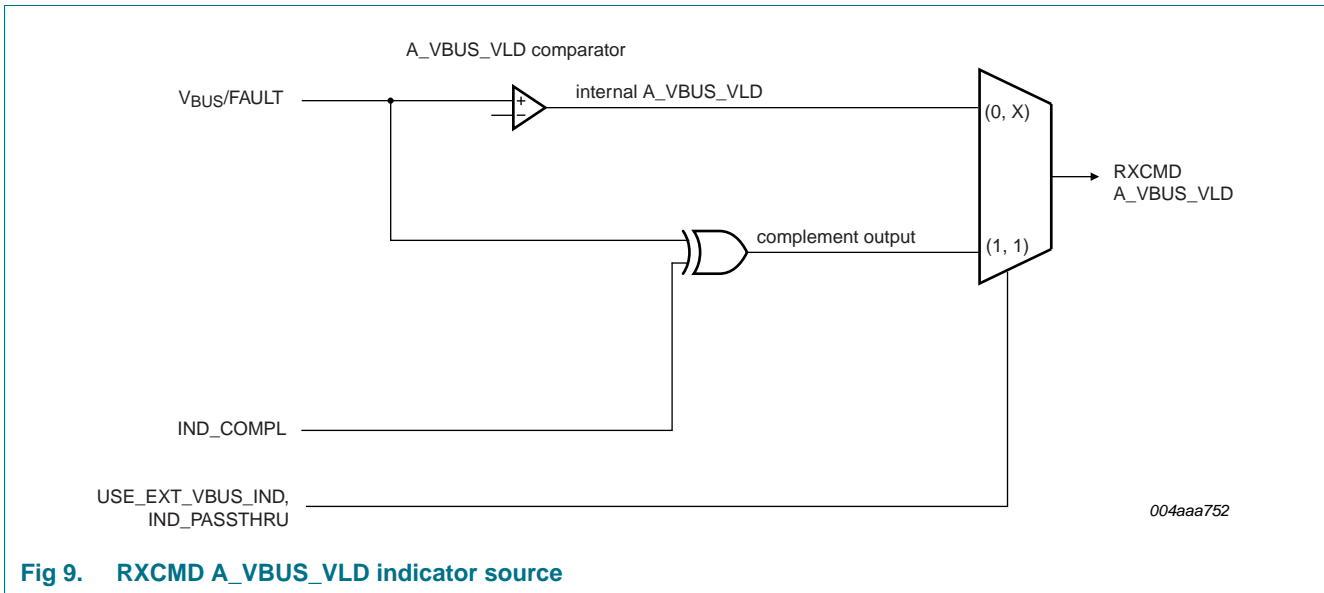

Fig 9. RXCMD A_VBUS_VLD indicator source

9.5.2.3 Using and selecting the V_{BUS} state encoding

The V_{BUS} state encoding is shown in [Table 10](#). The ISP1507 will send an RXCMD to the link whenever there is a change in the V_{BUS} state. To receive V_{BUS} state updates, the link must first enable the corresponding interrupts in the USB_INTR_EN_R_E and USB_INTR_EN_F_E registers.

The link can use the V_{BUS} state to monitor V_{BUS} and take appropriate action. [Table 14](#) shows the recommended usage for typical applications.

Table 14. V_{BUS} indicators in RXCMD required for typical applications

Application	A_VBUS_VLD	SESS_VLD	SESS_END
Standard host	yes	no	no
Standard peripheral	no	yes	no
OTG A-device	yes	yes	no
OTG B-device	no	yes	yes

Standard USB host controllers: For standard hosts, the system must be able to provide 500 mA on V_{BUS} in the range of 4.75 V to 5.25 V. An external circuit must be used to detect overcurrent conditions. If the external overcurrent detector provides a digital fault signal, then the fault signal must be connected to the ISP1507 FAULT input pin, and the link must do the following:

1. Set the IND_COMPL bit in the INTF_CTRL register (see [Section 10.1.3](#)) to logic 0 or logic 1, depending on the polarity of the external fault signal.
2. Set the USE_EXT_VBUS_IND bit in the OTG_CTRL register (see [Section 10.1.4](#)) to logic 1.
3. Set the IND_PASSTHRU bit in the INTF_CTRL register to logic 1 (mandatory).

Standard USB peripheral controllers: Standard peripherals must be able to detect when V_{BUS} is at a sufficient level for operation. SESS_VLD must be enabled to detect the start and end of USB peripheral operations. Detection of A_VBUS_VLD and SESS_END thresholds is not needed for standard peripherals.

OTG devices: When an OTG device is configured as an OTG A-device, it must be able to provide a minimum of 8 mA on V_{BUS} . If the OTG A-device provides less than 100 mA, then there is no need for an overcurrent detection circuit because the internal A_VBUS_VLD comparator is sufficient. If the OTG A-device provides more than 100 mA on V_{BUS} , an overcurrent detector must be used and [Section “Standard USB host controllers” on page 27](#) applies. The OTG A-device also uses $SESS_VLD$ to detect when an OTG B-device is initiating V_{BUS} pulsing SRP.

When an OTG device is configured as an OTG B-device, $SESS_VLD$ must be used to detect when V_{BUS} is at a sufficient level for operation. $SESS_END$ must be used to detect when V_{BUS} has dropped to a LOW level, allowing the B-device to safely initiate V_{BUS} pulsing SRP.

9.5.2.4 RxEvent encoding

The RxEvent field (see [Table 15](#)) of the RXCMD informs the link of information related packets received on the USB bus. RxActive and RxError are defined in *USB 2.0 Transceiver Macrocell Interface (UTMI) Specification Ver. 1.05*. HostDisconnect is defined in *UTMI+ Specification Rev. 1.0*. A short definition is also given in the following subsections.

Table 15. Encoded USB event signals

Value	RxActive	RxError	HostDisconnect
00	0	0	0
01	1	0	0
11	1	1	0
10	X	X	1

RxActive: When the ISP1507 has detected a SYNC pattern on the USB bus, it signals an RxActive event to the link. An RxActive event can be communicated using two methods. The first method is for the ISP1507 to simultaneously assert DIR and NXT. The second method is for the ISP1507 to send an RXCMD to the link with the RxActive field in RxEvent bits set to logic 1. The link must be able to detect both methods. RxActive frames the receive packet from the first byte to the last byte.

The link must assume that RxActive is set to logic 0 when indicated in an RXCMD or when DIR is deasserted, whichever occurs first.

The link uses RxActive to time high-speed packets and ensure that bus turnaround times are met. For more information on the USB packet timing, see [Section 9.8.1](#).

RxError: When the ISP1507 has detected an error while receiving a USB packet, it deasserts NXT and sends an RXCMD with the RxError field set to logic 1. The received packet is no longer valid and must be dropped by the link.

HostDisconnect: HostDisconnect is encoded into the RxEvent field of the RXCMD. HostDisconnect is valid only when the ISP1507 is configured as a host (both DP_PULLDOWN and DM_PULLDOWN are set to logic 1), and indicates to the host controller when a peripheral is connected or disconnected. The host controller must enable HostDisconnect by setting the HOST_DISCON_R and HOST_DISCON_F bits in the USB_INTR_EN_R_E and USB_INTR_EN_F_E registers, respectively. Changes in HostDisconnect will cause the PHY to send an RXCMD to the link with the updated value.

9.6 Register read and write operations

Figure 10 shows the register read and write sequences. The ISP1507 supports immediate addressing and extended addressing register operations. Extended register addressing is optional for links. Note that register operations will be aborted if the ISP1507 unexpectedly asserts DIR during the operation. When a register operation is aborted, the link must retry until successful. For more information on register operations, refer to *UTMI+ Low Pin Interface (ULPI) Specification Rev. 1.1*.

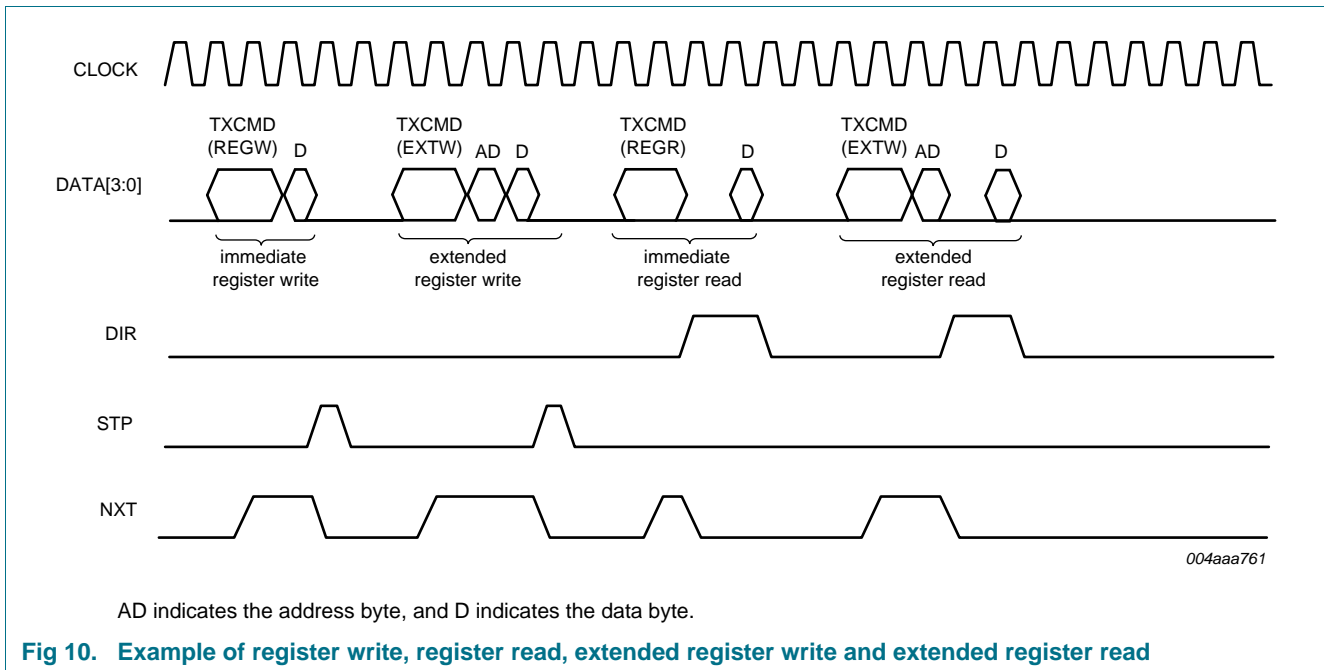

9.7 USB reset and high-speed detection handshake (chirp)

Figure 11 shows the sequence of events for USB reset and high-speed detection handshake (chirp). The sequence is shown for hosts and peripherals. Figure 11 does not show all RXCMD updates, and timing is not to scale. The sequence is as follows:

1. USB reset: The host detects a peripheral attachment as low-speed if DM is HIGH and as full-speed if DP is HIGH. If a host detects a full-speed peripheral, it resets the peripheral by writing to the Function Control register (see Section 10.1.2). XCVRSELECT[1:0] = 00b (high-speed) and TERMSELECT = 0b are then set which drives SE0 on the bus (DP and DM are connected to ground through 45 Ω). The host also sets OPMODE[1:0] = 10b for correct chirp transmit and receive. The start of SE0 is labeled T₀.

Remark: To receive chirp signaling, the host must also consider the high-speed differential receiver output. The host controller must interpret LINESTATE[1:0] as shown in Table 12.

2. High-speed detection handshake (chirp)
 - a. Peripheral chirp: After detecting SE0 for no less than 2.5 μ s, if the peripheral is capable of high-speed, it sets XCVRSELECT[1:0] = 00b (high-speed) and OPMODE[1:0] = 10b (chirp). The peripheral immediately follows this with a TXCMD (NOPID), transmitting a Chirp K for no less than 1 ms and ending no more than 7 ms after reset time T_0 . If the peripheral is in low-power mode, it must wake up its clock within 5.6 ms, leaving 200 μ s for the link to start transmitting the Chirp K, and 1.2 ms for the Chirp K to complete (worst case with 10 % slow clock).
 - b. Host chirp: If the host does not detect the peripheral chirp, it must continue asserting SE0 until the end of reset. If the host detects the peripheral Chirp K for no less than 2.5 μ s, then no more than 100 μ s after the bus leaves the Chirp K state, the host sends a TXCMD (NOPID) with an alternating sequence of Chirp Ks and Chirp Js. Each Chirp K or Chirp J must last no less than 40 μ s and no longer than 60 μ s.
 - c. High-speed idle: The peripheral must detect a minimum of Chirp K-J-K-J-K-J. Each Chirp K and Chirp J must be detected for at least 2.5 μ s. After seeing that minimum sequence, the peripheral sets TERMSELECT = 0b and OPMODE[1:0] = 00b. The peripheral is now in high-speed mode and sees !squelch (01b on LINESTATE). When the peripheral sees squelch (10b on LINESTATE), it knows that the host has completed chirp and waits for Hi-Speed USB traffic to begin. After transmitting the chirp sequence, the host changes OPMODE[1:0] to 00b and begins sending USB packets.

For more information, refer to *UTMI+ Low Pin Interface (ULPI) Specification Rev. 1.1*.

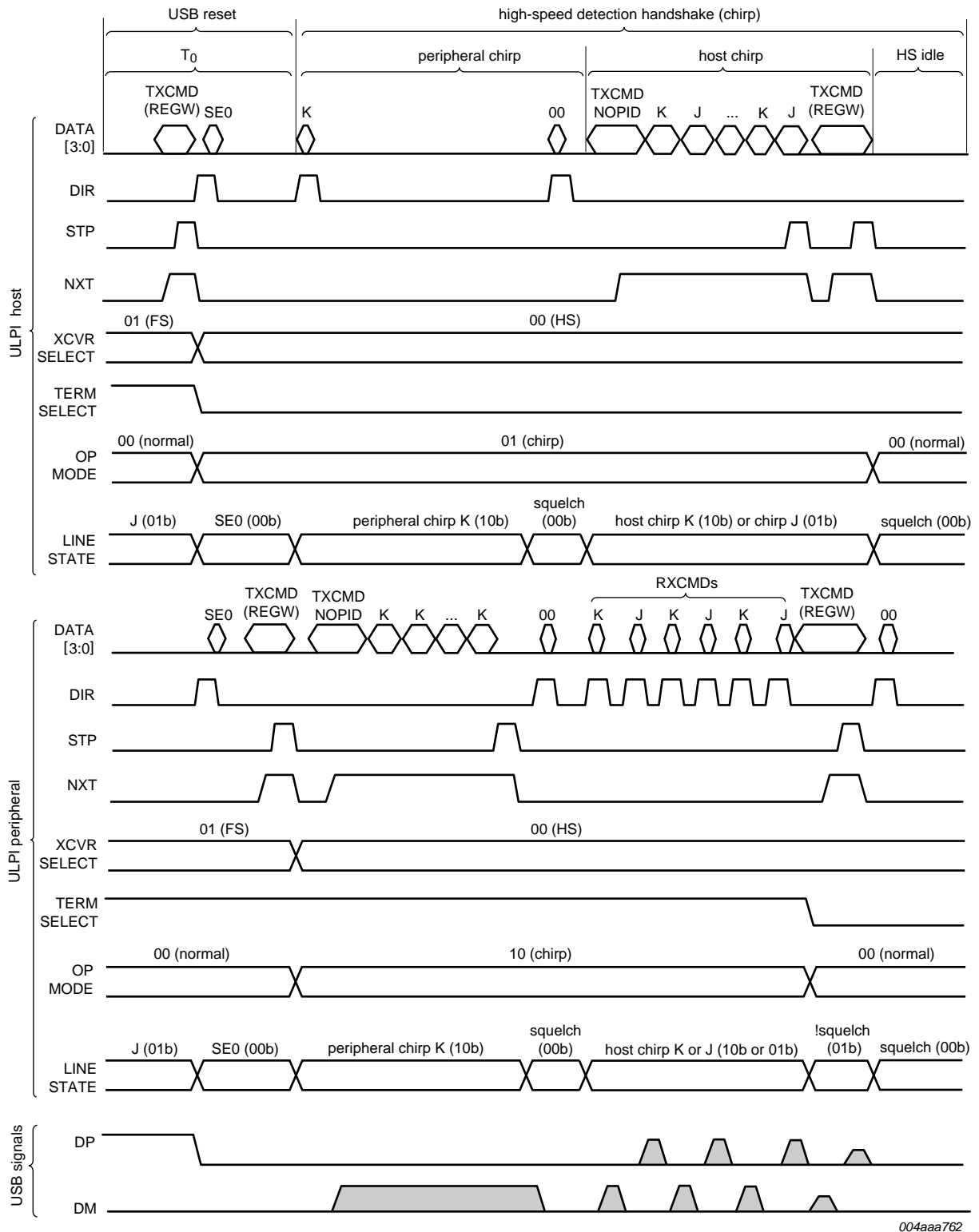

004aaa762

Fig 11. USB reset and high-speed detection handshake (chirp) sequence

9.8 USB packet transmit and receive

An example of a packet transmit and receive is shown in [Figure 12](#). For details on USB packets, refer to *UTMI+ Low Pin Interface (ULPI) Specification Rev. 1.1*.

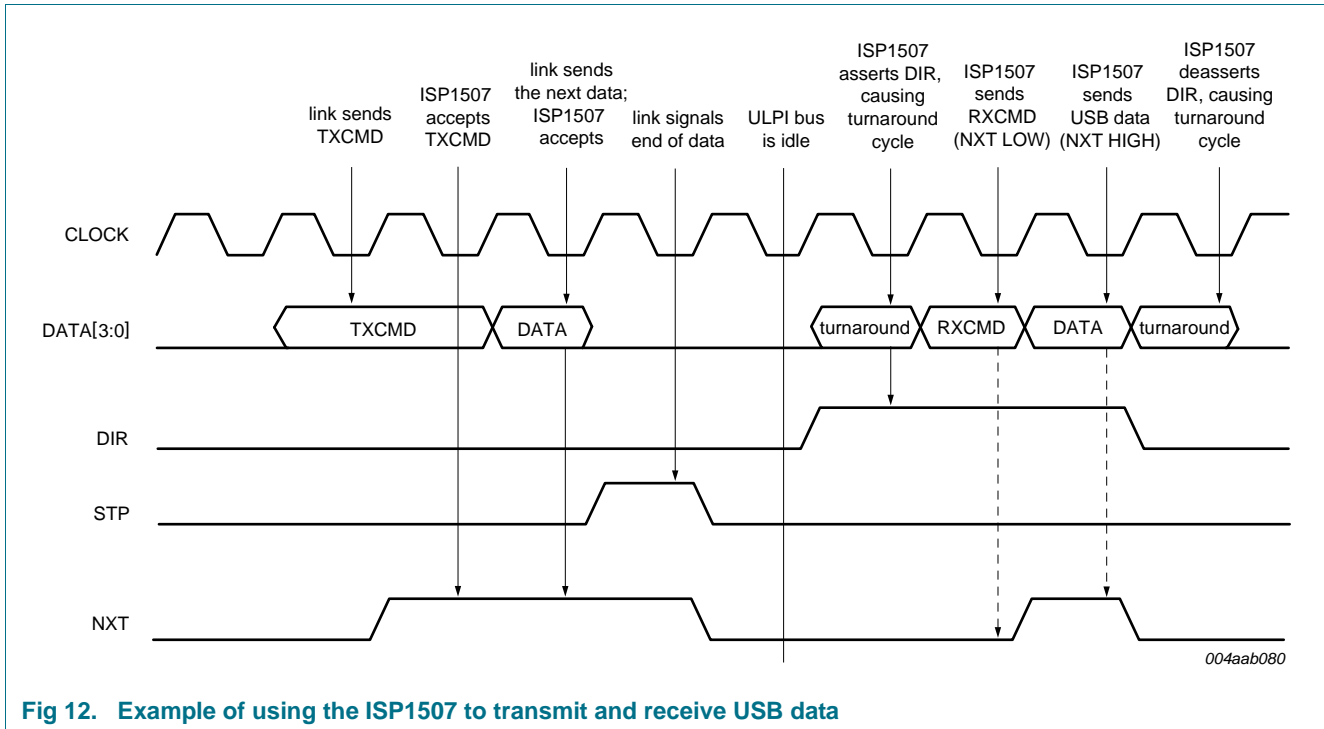

Fig 12. Example of using the ISP1507 to transmit and receive USB data

9.8.1 USB packet timing

9.8.1.1 ISP1507 pipeline delays

The ISP1507 delays are shown in [Table 16](#). For a detailed description, refer to *UTMI+ Low Pin Interface (ULPI) Specification Rev. 1.1*, Section 3.8.2.6.2.

Table 16. PHY pipeline delays

Parameter name ^[1]	High-speed PHY delay	Full-speed PHY delay	Low-speed PHY delay
RXCMD delay (J and K)	4	4	4
RXCMD delay (SE0)	4	4 to 6	16 to 18
TX start delay	1 to 2	6 to 10	74 to 75
TX end delay (packets)	3 to 4	not applicable	not applicable
TX end delay (SOF)	6 to 9	not applicable	not applicable
RX start delay	5 to 6	not applicable	not applicable
RX end delay	5 to 6	17 to 18	122 to 123

[1] According to *UTMI+ Low Pin Interface (ULPI) Specification Rev. 1.1*, Section 3.8.2.6, the TX and RX start or end delays must be used for high-speed inter-packet timing. If the link uses RXCMDs for high-speed inter-packet timing, the result cannot be guaranteed.

9.8.1.2 Allowed link decision time

The amount of clock cycles allocated to the link to respond to a received packet and correctly receive back-to-back packets is given in [Table 17](#). Link designs must follow values given in [Table 17](#) for correct USB system operation. Examples of high-speed packet sequences and timing are shown in [Figure 13](#) and [Figure 14](#). For details, refer to *UTMI+ Low Pin Interface (ULPI) Specification Rev. 1.1*, Section 3.8.2.6.3.

Table 17. Link decision times

Packet sequence	High-speed link delay	Full-speed link delay	Low-speed link delay	Definition
Transmit-Transmit (host only)	15 to 24	7 to 18	77 to 247	<p>Number of clock cycles a host link must wait before driving the TXCMD for the second packet.</p> <p>In high-speed, the link starts counting from the assertion of STP for the first packet.</p> <p>In full-speed, the link starts counting from the RXCMD, indicating LINESTATE has changed from SE0 to J for the first packet. The timing given ensures inter-packet delays of 2 bit times to 6.5 bit times.</p>
Receive-Transmit (host or peripheral)	1 to 14	7 to 18	77 to 247	<p>Number of clock cycles the link must wait before driving the TXCMD for the transmit packet.</p> <p>In high-speed, the link starts counting from the end of the receive packet; deassertion of DIR or an RXCMD indicating RxActive is LOW.</p> <p>In full-speed or low-speed, the link starts counting from the RXCMD, indicating LINESTATE has changed from SE0 to J for the receive packet. The timing given ensures inter-packet delays of 2 bit times to 6.5 bit times.</p>
Receive-Receive (peripheral only)	1	1	1	<p>Minimum number of clock cycles between consecutive receive packets. The link must be able to receive both packets.</p>
Transmit-Receive (host or peripheral)	92	80	718	<p>Host or peripheral transmits a packet and will time-out after this number of clock cycles if a response is not received. Any subsequent transmission can occur after this time.</p>

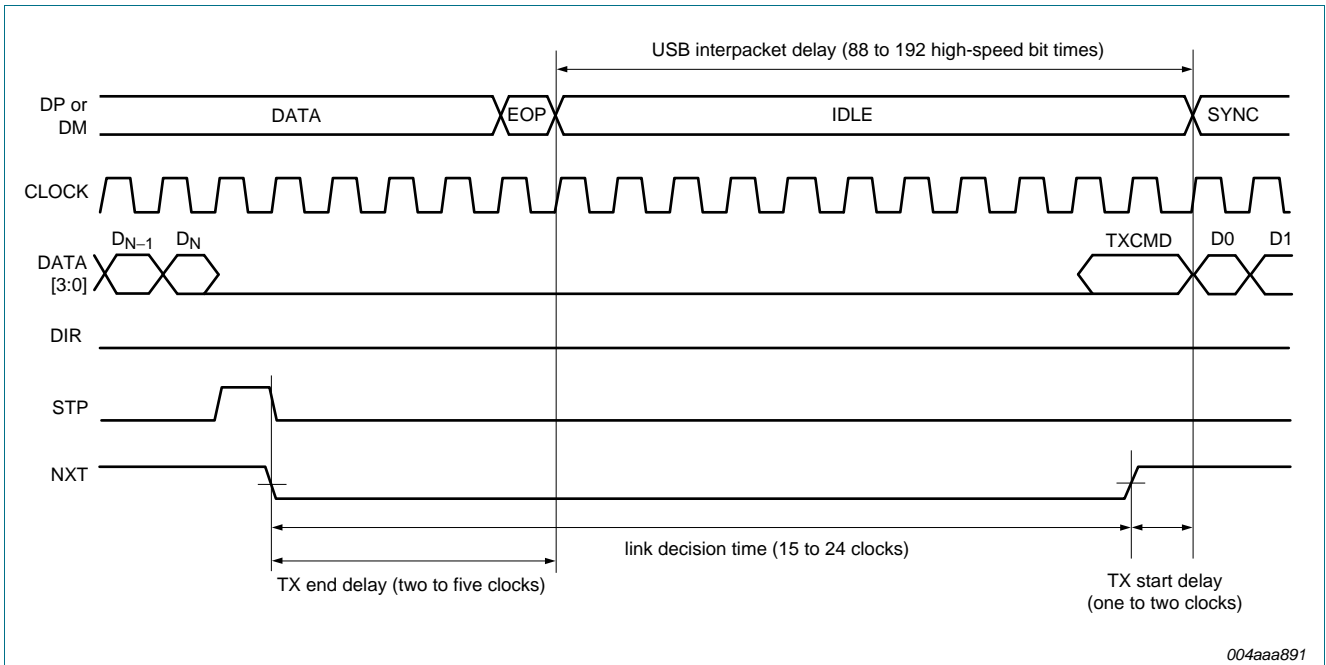

Fig 13. High-speed transmit-to-transmit packet timing

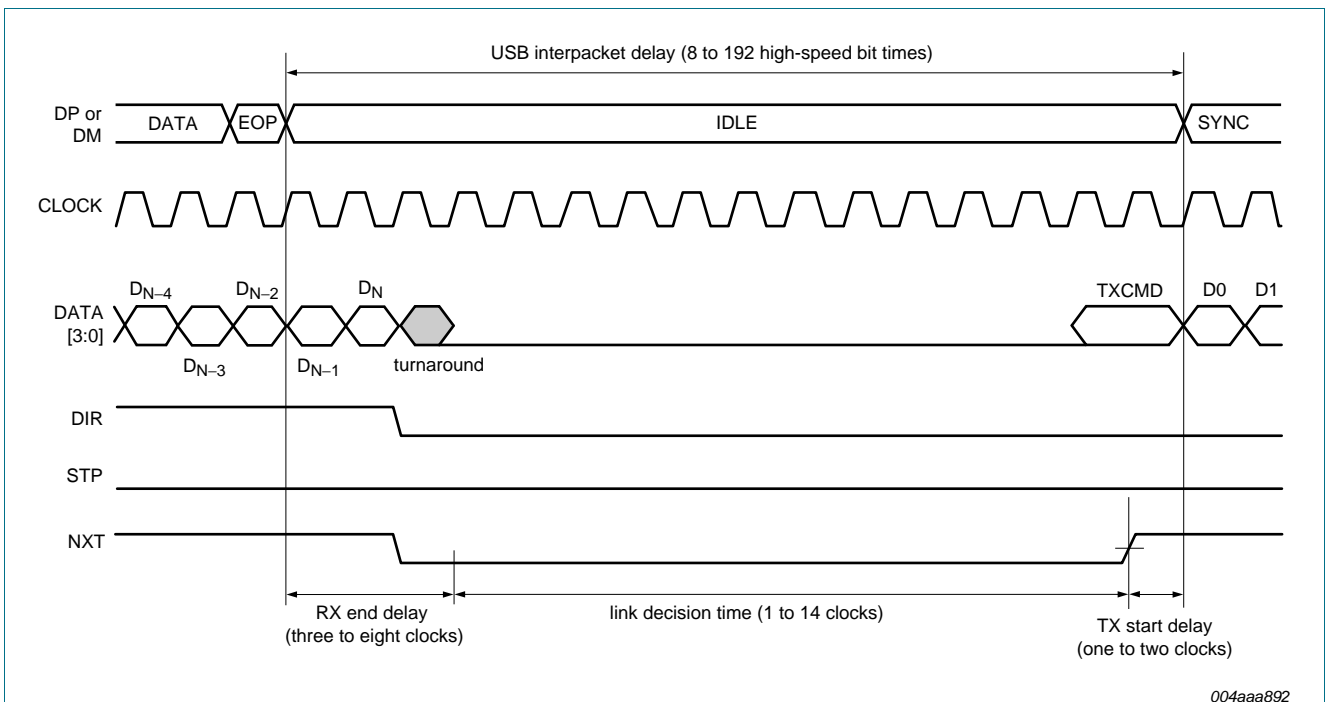
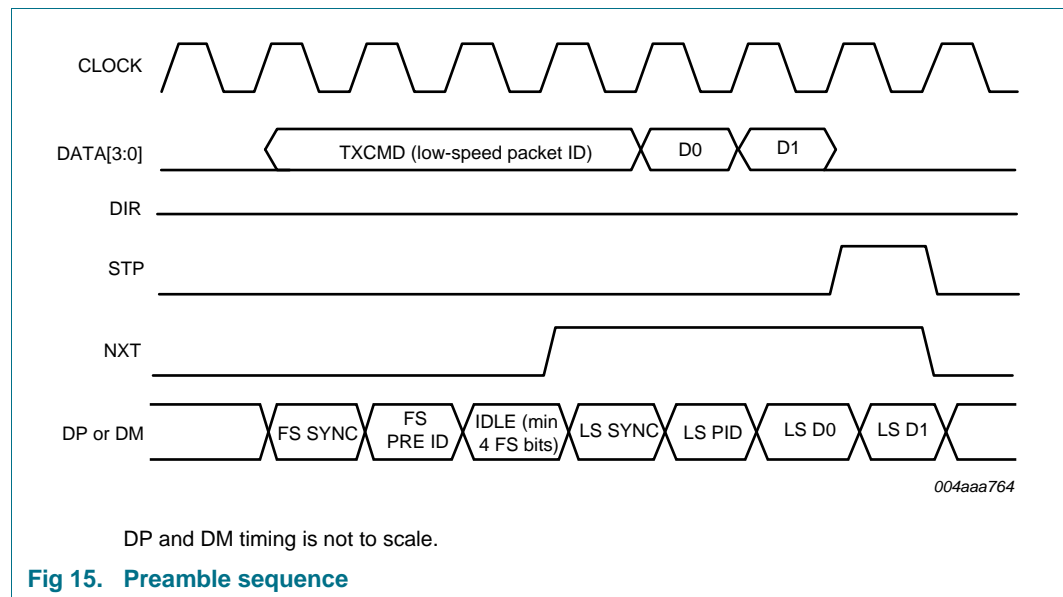

Fig 14. High-speed receive-to-transmit packet timing

9.9 Preamble

Preamble packets are headers to low-speed packets that must travel over a full-speed bus, between a host and a hub. To enter preamble mode, the link sets $XCVRSELECT[1:0] = 11b$ in the `FUNC_CTRL` register (see [Section 10.1.2](#)). When in preamble mode, the ISP1507 operates just as in full-speed mode, and sends all data with the full-speed rise time and fall time. Whenever the link transmits a USB packet in preamble mode, the ISP1507 will automatically send a preamble header at full-speed bit rate before sending the link packet at low-speed bit rate. The ISP1507 will ensure a minimum gap of four full-speed bit times between the last bit of the full-speed PRE PID and the first bit of the low-speed packet SYNC. The ISP1507 will drive a J for at least one full-speed bit time after sending the PRE PID, after which the pull-up resistor can hold the J state on the bus. An example transmit packet is shown in [Figure 15](#).

In preamble mode, the ISP1507 can also receive low-speed packets from the full-speed bus.



9.10 USB suspend and resume

9.10.1 Full-speed or low-speed host-initiated suspend and resume

[Figure 16](#) illustrates how a host or a hub places a full-speed or low-speed peripheral into suspend and sometime later initiates resume signaling to wake up the downstream peripheral. Note that [Figure 16](#) timing is not to scale, and does not show all RXCMD LINESTATE updates.

The sequence of events for a host and a peripheral, both with ISP1507, is as follows.

1. Idle: Initially, the host and the peripheral are idle. The host has its 15 k Ω pull-down resistors enabled (`DP_PULLDOWN` and `DM_PULLDOWN` are set to 1b), and 45 Ω terminations disabled (`TERMSELECT` is set to 1b). The peripheral has the 1.5 k Ω pull-up resistor connected to DP for full-speed or DM for low-speed (`TERMSELECT` is set to 1b).

2. Suspend: When the peripheral sees no bus activity for 3 ms, it enters the suspend state. The peripheral link places the PHY into low-power mode by clearing the SUSPENDM bit in the FUNC_CTRL register (see [Section 10.1.2](#)), causing the PHY to draw only suspend current. The host may or may not be powered down.
3. Resume K: When the host wants to wake up the peripheral, it sets OPMODE[1:0] to 10b and transmits a K for at least 20 ms. The peripheral link sees the resume K on LINESTATE, and asserts STP to wake up the PHY.
4. EOP: When STP is asserted, the ISP1507 on the host side automatically appends an EOP of two bits of SE0 at low-speed bit rate, followed by one bit of J. The ISP1507 on the host side knows to add the EOP because DP_PULLDOWN and DM_PULLDOWN are set to 1b for a host. After the EOP is completed, the host link sets OPMODE[1:0] to 00b for normal operation. The peripheral link sees the EOP and also resumes normal operation.

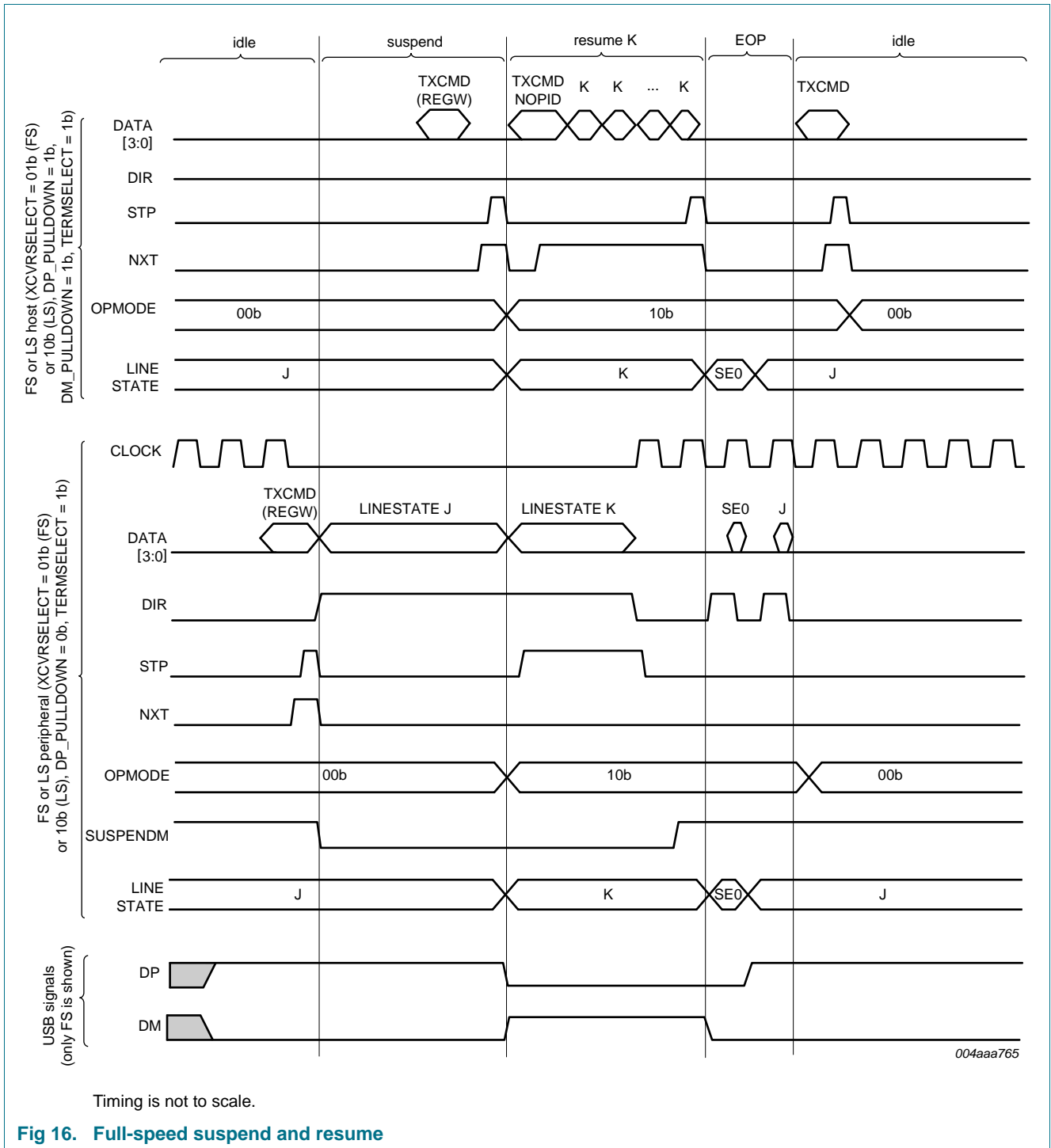

Fig 16. Full-speed suspend and resume

9.10.2 High-speed suspend and resume

Figure 17 illustrates how a host or a hub places a high-speed enabled peripheral into suspend and then initiates resume signaling. The high-speed peripheral will wake up and return to high-speed operations. Note that Figure 17 timing is not to scale, and does not show all RXCMD LINESTATE updates.

The sequence of events related to a host and a peripheral, both with ISP1507, is as follows.

1. High-speed idle: Initially, the host and the peripheral are idle. The host has its 15 k Ω pull-down resistors enabled (DP_PULLDOWN and DM_PULLDOWN are set to 1b) and 45 Ω terminations enabled (TERMSELECT is set to 0b). The peripheral has its 45 Ω terminations enabled (TERMSELECT is set to 0b).
2. Full-speed suspend: When the peripheral sees no bus activity for 3 ms, it enters the suspend state. The peripheral link places the ISP1507 into full-speed mode (XCVRSELECT is set to 01b), removes 45 Ω terminations, and enables the 1.5 k Ω pull-up resistor on DP (TERMSELECT is set to 1b). The peripheral link then places the ISP1507 into low-power mode by clearing SUSPENDM, causing the ISP1507 to draw only suspend current. The host also changes the ISP1507 to full-speed (XCVRSELECT is set to 01b), removes 45 Ω terminations (TERMSELECT is set to 1b), and then may or may not be powered down.
3. Resume K: When the host wants to wake up the peripheral, it sets OPMODE to 10b and transmits a full-speed K for at least 20 ms. The peripheral link sees the resume K (10b) on LINESTATE, and asserts STP to wake up the ISP1507.
4. High-speed traffic: The host link sets high-speed (XCVRSELECT is set to 00b) and enables its 45 Ω terminations (TERMSELECT is set to 0b). The peripheral link sees SE0 on LINESTATE and also sets high-speed (XCVRSELECT is set to 00b) and enables its 45 Ω terminations (TERMSELECT is set to 0b). The host link sets OPMODE to 00b for normal high-speed operation.

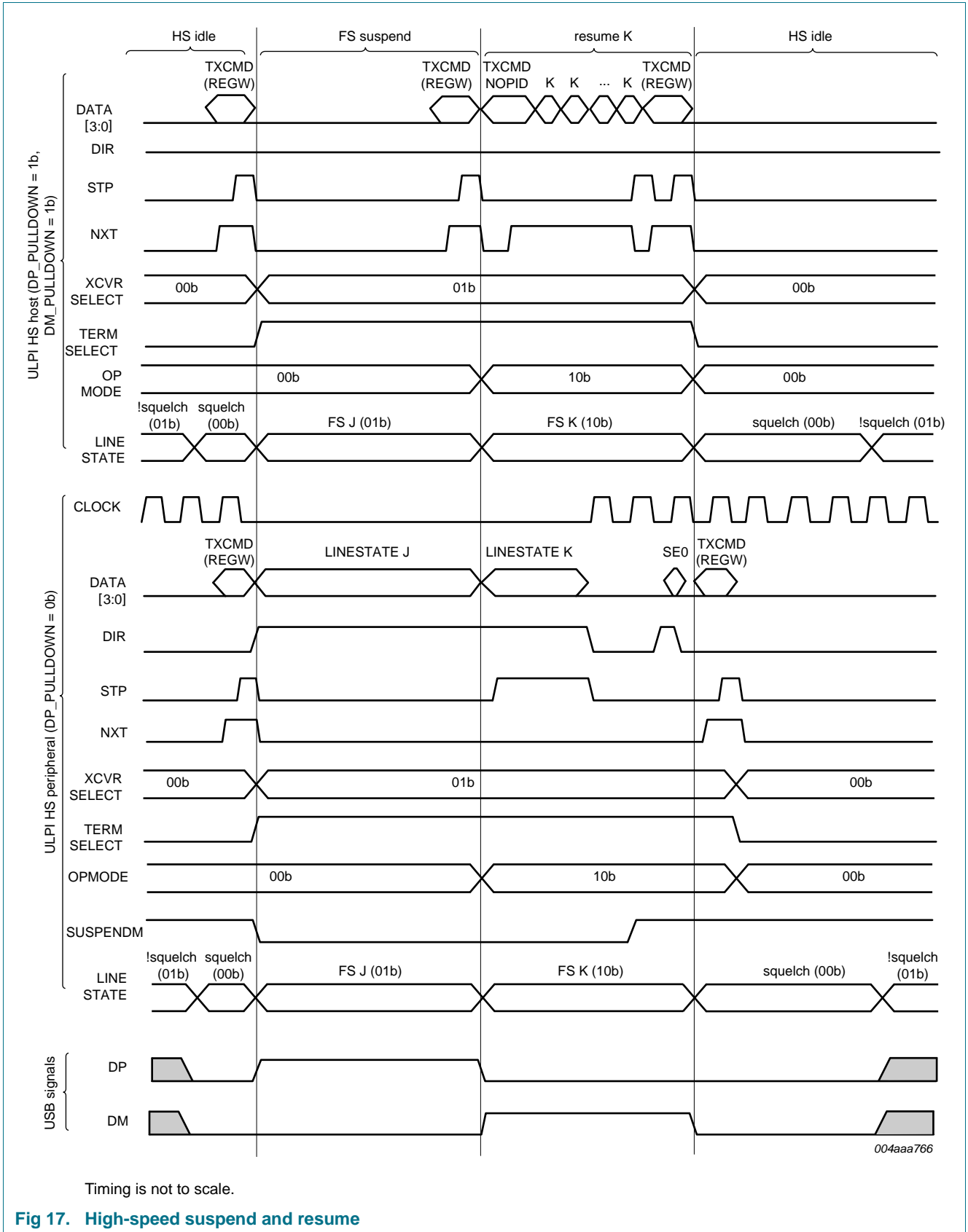

Fig 17. High-speed suspend and resume

9.10.3 Remote wake-up

The ISP1507 supports peripherals that initiate remote wake-up resume. When placed into USB suspend, the peripheral link remembers at what speed it was originally operating. Depending on the original speed, the link follows one of the protocols detailed here. In [Figure 18](#), timing is not to scale, and not all RXCMD LINESTATE updates are shown.

The sequence of events related to a host and a peripheral, both with ISP1507, is as follows.

1. Both the host and the peripheral are assumed to be in low-power mode.
2. The peripheral begins remote wake-up by re-enabling its clock and setting its SUSPENDM bit to 1b.
3. The peripheral begins driving K on the bus to signal resume. Note that the peripheral link must assume that LINESTATE is K (01b) while transmitting because it will not receive any RXCMDs.
4. The host recognizes resume, re-enables its clock and sets its SUSPENDM bit.
5. The host takes over resume driving within 1 ms of detecting the remote wake-up.
6. The peripheral stops driving resume.
7. The peripheral sees the host continuing to drive resume.
8. The host stops driving resume and the ISP1507 automatically adds the EOP to the end of resume. The peripheral recognizes the EOP as the end of resume.
9. Both the host and the peripheral revert to normal operation by writing 00b to OPMODE. If the host or the peripheral was previously in high-speed mode, it must revert to high-speed before the SE0 of the EOP is completed. This can be achieved by writing XCVRSELECT[1:0] = 00b and TERMSELECT = 0b after LINESTATE indicates SE0.

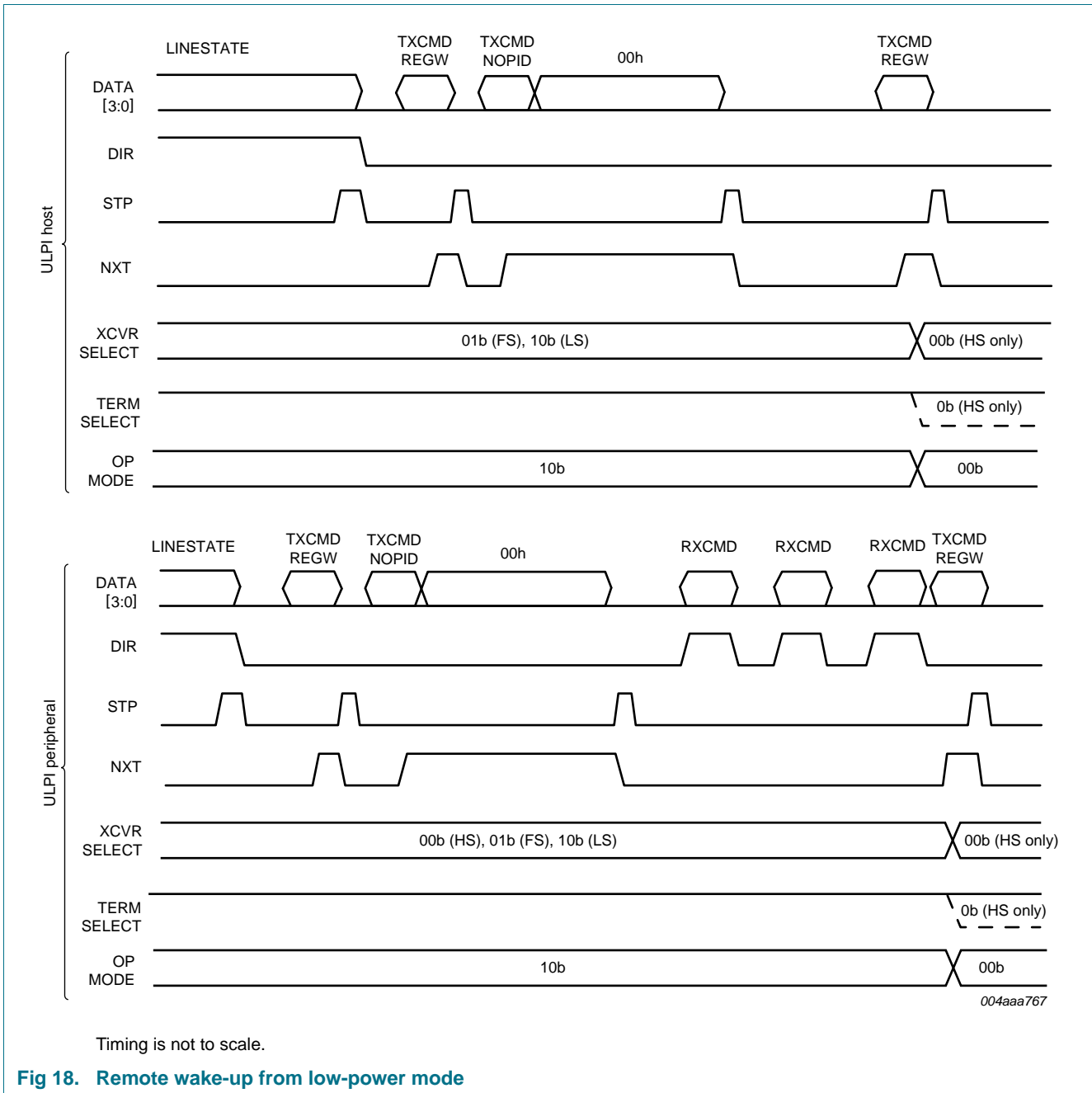

Fig 18. Remote wake-up from low-power mode

9.11 No automatic SYNC and EOP generation (optional)

This setting allows the link to turn off the automatic SYNC and EOP generation, and must be used for high-speed packets only. It is provided for backward compatibility with legacy controllers that include SYNC and EOP bytes in the data payload when transmitting packets. The ISP1507 will not automatically generate SYNC and EOP patterns when OPMODE[1:0] is set to 11b. The ISP1507 will still NRZI encode data and perform bit stuffing. An example of a sequence is shown in [Figure 19](#). The link must always send packets using the TXCMD (NOPID) type. The ISP1507 does not provide a mechanism to control bit stuffing in individual bytes, but will automatically turn off bit stuffing for EOP when STP is asserted with data set to FEh. If data is set to 00h when STP is asserted, the

PHY will not transmit any EOP. The ISP1507 will also detect if the PID byte is A5h, indicating an SOF packet, and automatically send a long EOP when STP is asserted. To transmit chirp and resume signaling, the link must set OPMODE to 10b.

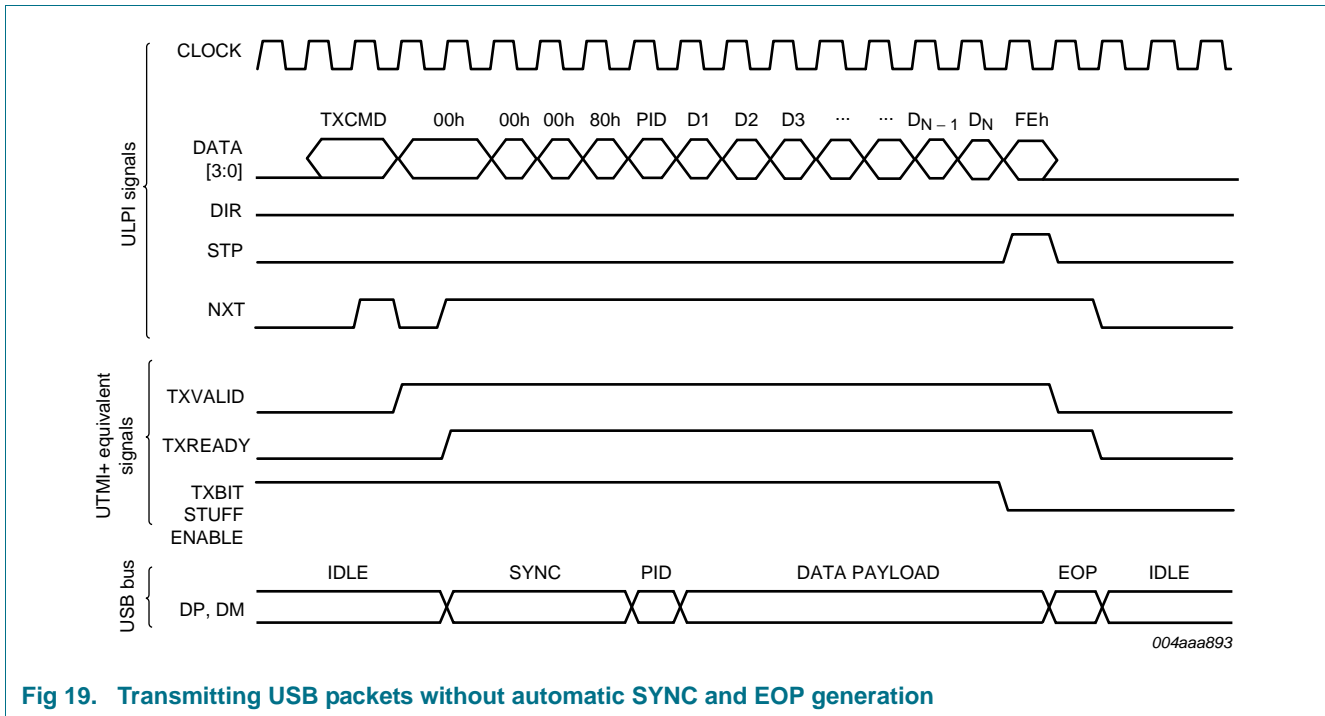

Fig 19. Transmitting USB packets without automatic SYNC and EOP generation

9.12 On-The-Go operations

On-The-Go (OTG) is a supplement to *Universal Serial Bus Specification Rev. 2.0* that allows a portable USB device to assume the role of a limited USB host by defining improvements, such as a small connector and low power. Non-portable devices, such as standard hosts and embedded hosts, can also benefit from OTG features.

The ISP1507 OTG PHY is designed to support all the tasks specified in the OTG supplement. The ISP1507 provides the front-end analog support for Host Negotiation Protocol (HNP) and Session Request Protocol (SRP) for dual-role devices. The supporting components include:

- Built-in 5 V charge pump
- Voltage comparators
 - A_VBUS_VLD
 - SESS_VLD (session valid, can be used for both A-session and B-session valid)
 - SESS_END (session end)
- Pull-up and pull-down resistors on DP and DM
- ID detector indicates if micro-A or micro-B plug is inserted
- Charge and discharge resistors on V_{BUS}

The following subsections describe how to use the ISP1507 OTG components.

9.12.1 OTG charge pump

A description of the charge pump is given in [Section 7.6.4](#). When the controller is configured as an A-device, it can provide the V_{BUS} power by turning on the charge pump. Control of the charge pump is described in [Section 9.4.1](#) and [Section 10.1.4](#).

9.12.2 OTG comparators

The ISP1507 provides comparators that conform to *On-The-Go Supplement to the USB 2.0 Specification Rev. 1.3* requirements of $V_{A_VBUS_VLD}$, $V_{A_SESS_VLD}$, $V_{B_SESS_VLD}$ and $V_{B_SESS_END}$. In this data sheet, $V_{A_SESS_VLD}$ and $V_{B_SESS_VLD}$ are combined into $V_{B_SESS_VLD}$. Comparators are described in [Section 7.6.2](#). Changes in comparator values are communicated to the link by RXCMDs as described in [Section 9.5.2.2](#). Control over comparators is described in [Section 10.1.5](#) to [Section 10.1.8](#).

9.12.3 Pull-up and pull-down resistors

The USB resistors on DP and DM can be used to initiate data-line pulsing SRP. The link must set the required bus state using mode settings in [Table 7](#).

9.12.4 ID detection

The ISP1507 provides an internal pull-up resistor to sense the value of the ID pin. The pull-up resistor must first be enabled by setting the ID_PULLUP register bit to logic 1. If the value on ID has changed, the ISP1507 will send an RXCMD or interrupt to the link by time t_{ID} . If the link does not receive any RXCMD or interrupt by t_{ID} , then the ID value has not changed.

9.12.5 V_{BUS} charge and discharge resistors

A pull-up resistor, $R_{UP(VBUS)}$, is provided to perform V_{BUS} pulsing SRP. A B-device is allowed to charge V_{BUS} above the session valid threshold to request the host to turn on the V_{BUS} power.

A pull-down resistor, $R_{DN(VBUS)}$, is provided for a B-device to discharge V_{BUS} . This is done whenever the A-device turns off the V_{BUS} power. The B-device can use the pull-down resistor to ensure V_{BUS} is below $V_{B_SESS_END}$ before starting a session.

For details, refer to *On-The-Go Supplement to the USB 2.0 Specification Rev. 1.3*.

9.13 Serial mode

The ISP1507 supports 3-pin serial mode, controlled by bit 3PIN_FSLs_SERIAL of the INTF_CTRL register (see [Section 10.1.3](#)). For details, refer to *UTMI+ Low Pin Interface (ULPI) Specification Rev. 1.1*, Section 3.10.

[Figure 20](#) provides an example of 3-pin serial mode.

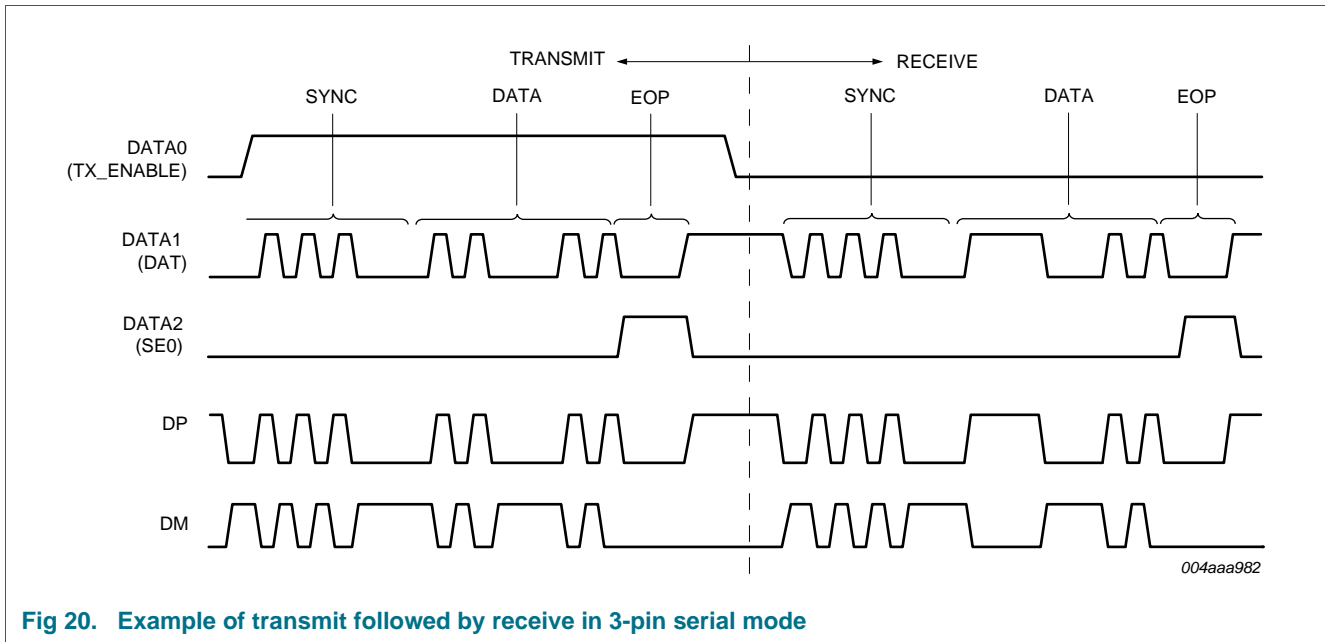

Fig 20. Example of transmit followed by receive in 3-pin serial mode

9.14 Aborting transfers

The ISP1507 supports aborting transfers on the ULPI bus. For details, refer to *UTMI+ Low Pin Interface (ULPI) Specification Rev. 1.1*, Section 3.8.4.

9.15 Avoiding contention on the ULPI data bus

Because the ULPI data bus is bidirectional, avoid situations in which both the link and the PHY simultaneously drive the data bus.

The following points must be considered while implementing the data bus drive control on the link.

After power-up and clock stabilization, default states are as follows:

- The ISP1507 drives DIR to LOW.
- The data bus is input to the ISP1507.
- The ULPI link data bus is output, with all data bus lines driven to LOW.

When the ISP1507 wants to take control of the data bus to initiate a data transfer, it changes the DIR value from LOW to HIGH.

At this point, the link must disable its output buffers. This must be as fast as possible so the link must use a combinational path from DIR.

The ISP1507 will not immediately enable its output buffers, but will delay the enabling of its buffers until the next clock edge, avoiding bus contention.

When the data transfer is no longer required by the ISP1507, it changes DIR from HIGH to LOW and starts to immediately turn off its output drivers. The link senses the change of DIR from HIGH to LOW, but delays enabling its output buffers for one CLOCK cycle, avoiding data bus contention.

10. Register map

Table 18. Immediate register set overview

Field name	Size (bit)	Address (6 bit)				References
		R ^[1]	W ^[2]	S ^[3]	C ^[4]	
VENDOR_ID_LOW	8	00h	-	-	-	Section 10.1.1 on page 46
VENDOR_ID_HIGH	8	01h	-	-	-	
PRODUCT_ID_LOW	8	02h	-	-	-	
PRODUCT_ID_HIGH	8	03h	-	-	-	
FUNC_CTRL	8	04h to 06h	04h	05h	06h	Section 10.1.2 on page 46
INTF_CTRL	8	07h to 09h	07h	08h	09h	Section 10.1.3 on page 47
OTG_CTRL	8	0Ah to 0Ch	0Ah	0Bh	0Ch	Section 10.1.4 on page 48
USB_INTR_EN_R_E	8	0Dh to 0Fh	0Dh	0Eh	0Fh	Section 10.1.5 on page 49
USB_INTR_EN_F_E	8	10h to 12h	10h	11h	12h	Section 10.1.6 on page 50
USB_INTR_STAT	8	13h	-	-	-	Section 10.1.7 on page 50
USB_INTR_L	8	14h	-	-	-	Section 10.1.8 on page 51
DEBUG	8	15h	-	-	-	Section 10.1.9 on page 52
SCRATCH	8	16h to 18h	16h	17h	18h	Section 10.1.10 on page 52
Reserved (do not use)	-			19h to 2Eh		Section 10.1.11 on page 52
Access extended register set	8	-	2Fh	-	-	Section 10.1.12 on page 52
Vendor-specific register	8			30h to 3Ch		Section 10.1.13 on page 52
PWR_CTRL	8			3Dh to 3Fh		Section 10.1.14 on page 52

- [1] Read (R): A register can be read. Read-only if this is the only mode given.
- [2] Write (W): The pattern on the data bus will be written over all bits of a register.
- [3] Set (S): The pattern on the data bus is OR-ed with and written to a register.
- [4] Clear (C): The pattern on the data bus is a mask. If a bit in the mask is set, then the corresponding register bit will be set to zero (cleared).

Table 19. Extended register set overview

Field name	Size (bit)	Address (6 bit)				References
		R ^[1]	W ^[2]	S ^[3]	C ^[4]	
Maps to immediate register set above	8			00h to 3Fh		Section 10.2 on page 53
Reserved (do not use)	8			40h to FFh		

- [1] Read (R): A register can be read. Read-only if this is the only mode given.
- [2] Write (W): The pattern on the data bus will be written over all bits of a register.
- [3] Set (S): The pattern on the data bus is OR-ed with and written to a register.
- [4] Clear (C): The pattern on the data bus is a mask. If a bit in the mask is set, then the corresponding register bit will be set to zero (cleared).

10.1 Immediate register set

10.1.1 Vendor ID and Product ID registers

10.1.1.1 VENDOR_ID_LOW register

[Table 20](#) shows the bit description of the register.

Table 20. VENDOR_ID_LOW - Vendor ID Low register (address R = 00h) bit description

Legend: * reset value

Bit	Symbol	Access	Value	Description
7 to 0	VENDOR_ID_LOW[7:0]	R	CCh*	Vendor ID Low: Lower byte of the ST-Ericsson vendor ID supplied by USB-IF; has a fixed value of CCh

10.1.1.2 VENDOR_ID_HIGH register

The bit description of the register is given in [Table 21](#).

Table 21. VENDOR_ID_HIGH - Vendor ID High register (address R = 01h) bit description

Legend: * reset value

Bit	Symbol	Access	Value	Description
7 to 0	VENDOR_ID_HIGH[7:0]	R	04h*	Vendor ID High: Upper byte of the ST-Ericsson vendor ID supplied by USB-IF; has a fixed value of 04h

10.1.1.3 PRODUCT_ID_LOW register

The bit description of the PRODUCT_ID_LOW register is given in [Table 22](#).

Table 22. PRODUCT_ID_LOW - Product ID Low register (address R = 02h) bit description

Legend: * reset value

Bit	Symbol	Access	Value	Description
7 to 0	PRODUCT_ID_LOW[7:0]	R	06h*	Product ID Low: Lower byte of the ST-Ericsson product ID number; has a fixed value of 06h

10.1.1.4 PRODUCT_ID_HIGH register

The bit description of the register is given in [Table 23](#).

Table 23. PRODUCT_ID_HIGH - Product ID High register (address R = 03h) bit description

Legend: * reset value

Bit	Symbol	Access	Value	Description
7 to 0	PRODUCT_ID_HIGH[7:0]	R	15h*	Product ID High: Upper byte of the ST-Ericsson product ID number; has a fixed value of 15h

10.1.2 FUNC_CTRL register

This register controls UTMI function settings of the PHY. The bit allocation of the register is given in [Table 24](#).

Table 24. FUNC_CTRL - Function Control register (address R = 04h to 06h, W = 04h, S = 05h, C = 06h) bit allocation

Bit	7	6	5	4	3	2	1	0
Symbol	reserved	SUSPENDM	RESET	OPMODE[1:0]		TERM SELECT	XCVRSELECT[1:0]	
Reset	0	1	0	0	0	0	0	1
Access	R/W/S/C	R/W/S/C	R/W/S/C	R/W/S/C	R/W/S/C	R/W/S/C	R/W/S/C	R/W/S/C

Table 25. FUNC_CTRL - Function Control register (address R = 04h to 06h, W = 04h, S = 05h, C = 06h) bit description

Bit	Symbol	Description
7	-	reserved
6	SUSPENDM	<p>Suspend LOW: Active LOW PHY suspend.</p> <p>Places the PHY into low-power mode. The PHY will power down all blocks, except the full-speed receiver, OTG comparators and ULPI pins.</p> <p>To come out of low-power mode, the link must assert STP. The PHY will automatically clear this bit when it exits low-power mode.</p> <p>0b — Low-power mode 1b — Powered (default)</p>
5	RESET	<p>Reset: Active HIGH transceiver reset.</p> <p>After the link sets this bit, the PHY will assert DIR and reset the digital core. This does not reset the ULPI interface or the ULPI register set.</p> <p>When reset is completed, the PHY will deassert DIR and automatically clear this bit, followed by an RXCMD update to the link.</p> <p>0b — Do not reset (default) 1b — Reset</p> <p>The link must wait for DIR to deassert before using the ULPI bus. Does not reset the ULPI interface or ULPI register set.</p>
4 to 3	OPMODE[1:0]	<p>Operation Mode: Selects the required bit-encoding style during transmit.</p> <p>00b — Normal operation (default) 01b — Non-driving 10b — Disable bit-stuffing and NRZI encoding 11b — Do not automatically add SYNC and EOP when transmitting; must be used only for high-speed packets</p>
2	TERMSELECT	<p>Termination Select: Controls the internal 1.5 kΩ full-speed pull-up resistor and 45 Ω high-speed terminations. Control over bus resistors changes, depending on XCVRSELECT[1:0], OPMODE[1:0], DP_PULLDOWN and DM_PULLDOWN, as shown in Table 7.</p>
1 to 0	XCVRSELECT [1:0]	<p>Transceiver Select: Selects the required transceiver speed.</p> <p>00b — Enable the high-speed transceiver 01b — Enable the full-speed transceiver (default) 10b — Enable the low-speed transceiver 11b — Enable the full-speed transceiver for low-speed packets (full-speed preamble is automatically prefixed)</p>

10.1.3 INTF_CTRL register

The INTF_CTRL register enables alternative interfaces. All of these modes are optional features provided for legacy link cores. Setting more than one of these fields results in undefined behavior. [Table 26](#) provides the bit allocation of the register.

Table 26. INTF_CTRL - Interface Control register (address R = 07h to 09h, W = 07h, S = 08h, C = 09h) bit allocation

Bit	7	6	5	4	3	2	1	0
Symbol	INTF_PROT_DIS	IND_PASS_THRU	IND_COMPL	reserved	CLOCK_SUSPENDM	reserved	3PIN_FSL_SERIAL	reserved
Reset	0	0	0	0	0	0	0	0
Access	R/W/S/C	R/W/S/C	R/W/S/C	R/W/S/C	R/W/S/C	R/W/S/C	R/W/S/C	R/W/S/C

Table 27. INTF_CTRL - Interface Control register (address R = 07h to 09h, W = 07h, S = 08h, C = 09h) bit description

Bit	Symbol	Description
7	INTF_PROT_DIS	<p>Interface Protect Disable: Controls circuitry built into the ISP1507 to protect the ULPI when the link 3-states STP and DATA[3:0]. When this bit is enabled, the ISP1507 will automatically detect when the link stops driving STP.</p> <p>0b — Enables the interface protect circuit (default). The ISP1507 attaches a weak pull-up resistor on STP. If STP is unexpectedly HIGH, the ISP1507 attaches weak pull-down resistors on DATA[3:0], protecting data inputs.</p> <p>1b — Disables the interface protect circuit, detaches weak pull-down resistors on DATA[3:0], and a weak pull-up resistor on STP.</p>
6	IND_PASSTHRU	<p>Indicator Pass-through: The ISP1507 does not support the qualification of an external FAULT with the internal V_{A_VBUS_VLD} comparator. Either a digital FAULT is input on the V_{BUS}/FAULT pin or the V_{BUS} power is connected to the V_{BUS}/FAULT pin, not both. This bit must always be set to logic 1.</p> <p>0b — Not supported (default).</p> <p>1b — The complement output signal is not qualified with the internal A_VBUS_VLD comparator. The link must always set this bit to logic 1.</p>
5	IND_COMPL	<p>Indicator Complement: Informs the PHY to invert the FAULT input signal, generating the complement output. For details, see Section 9.5.2.2.</p> <p>0b — The ISP1507 will not invert the FAULT signal (default).</p> <p>1b — The ISP1507 will invert the FAULT signal.</p>
4	-	reserved
3	CLOCK_SUSPENDM	<p>Clock Suspend LOW: Active LOW clock suspend.</p> <p>Powers down the internal clock circuitry only. By default, the clock will not be powered in 3-pin serial mode.</p> <p>Valid only in 3-pin serial mode. Valid only when SUSPENDM is set to logic 1, otherwise this bit is ignored.</p> <p>0b — Clock will not be powered in 3-pin serial mode (default).</p> <p>1b — Clock will be powered in 3-pin serial mode.</p>
2	-	reserved
1	3PIN_FSLS_SERIAL	<p>3-Pin Full-Speed Low-Speed Serial Mode: Changes the ULPI to a 3-bit serial interface. The PHY will automatically clear this bit when 3-pin serial mode is exited.</p> <p>0b — Full-speed or low-speed packets are sent using the parallel interface (default).</p> <p>1b — Full-speed or low-speed packets are sent using the 3-pin serial interface.</p>
0	-	reserved

10.1.4 OTG_CTRL register

This register controls various OTG functions of the ISP1507. The bit allocation of the OTG_CTRL register is given in [Table 28](#).

Table 28. OTG_CTRL - OTG Control register (address R = 0Ah to 0Ch, W = 0Ah, S = 0Bh, C = 0Ch) bit allocation

Bit	7	6	5	4	3	2	1	0
Symbol	USE_EXT_VBUS_IND	DRV_VBUS_EXT	DRV_VBUS	CHRG_VBUS	DISCHRG_VBUS	DM_PULL_DOWN	DP_PULL_DOWN	ID_PULL_UP
Reset	0	0	0	0	0	1	1	0
Access	R/W/S/C	R/W/S/C	R/W/S/C	R/W/S/C	R/W/S/C	R/W/S/C	R/W/S/C	R/W/S/C

Table 29. OTG_CTRL - OTG Control register (address R = 0Ah to 0Ch, W = 0Ah, S = 0Bh, C = 0Ch) bit description

Bit	Symbol	Description
7	USE_EXT_VBUS_IND	<p>Use External V_{BUS} Indicator: Informs the PHY to use an external V_{BUS} overcurrent indicator.</p> <p>0b — Use the internal OTG comparator (default).</p> <p>1b — Use the external V_{BUS} valid indicator signal input from the FAULT pin.</p>
6	DRV_VBUS_EXT	<p>Drive V_{BUS} External: Selects between the internal and external 5 V V_{BUS} supply. Using an external charge pump or a 5 V supply is optional.</p> <p>0b — Drives V_{BUS} using the internal charge pump. Also ensures PSW_N is not driven to LOW (default).</p> <p>1b — Drives V_{BUS} using the external charge pump or the 5 V supply. Drives PSW_N to LOW.</p>
5	DRV_VBUS	<p>Drive V_{BUS}: Signals the ISP1507 to drive 5 V on V_{BUS}. If DRV_VBUS_EXT is set to logic 1, then setting DRV_VBUS is optional.</p> <p>0b — Do not drive V_{BUS} (default).</p> <p>1b — Drive 5 V on V_{BUS}.</p>
4	CHRG_VBUS	<p>Charge V_{BUS}: Charges V_{BUS} through a resistor. Used for the V_{BUS} pulsing SRP. The link must first check that V_{BUS} is discharged (see bit DISCHRG_VBUS), and that both the DP and DM data lines have been LOW (SE0) for 2 ms.</p> <p>0b — Do not charge V_{BUS} (default).</p> <p>1b — Charge V_{BUS}.</p>
3	DISCHRG_VBUS	<p>Discharge V_{BUS}: Discharges V_{BUS} through a resistor. If the link sets this bit to logic 1, it waits for an RXCMD indicating that SESS_END has changed from 0 to 1, and then resets this bit to 0 to stop the discharge.</p> <p>0b — Do not discharge V_{BUS} (default).</p> <p>1b — Discharge V_{BUS}.</p>
2	DM_PULL_DOWN	<p>DM Pull Down: Enables the 15 kΩ pull-down resistor on DM.</p> <p>0b — Pull-down resistor is not connected to DM.</p> <p>1b — Pull-down resistor is connected to DM (default).</p>
1	DP_PULL_DOWN	<p>DP Pull Down: Enables the 15 kΩ pull-down resistor on DP.</p> <p>0b — Pull-down resistor is not connected to DP.</p> <p>1b — Pull-down resistor is connected to DP (default).</p>
0	ID_PULLUP	<p>ID Pull Up: Connects a pull-up to the ID line and enables sampling of the ID level. Disabling the ID line sampler will reduce the PHY power consumption.</p> <p>0b — Disables sampling of the ID line (default).</p> <p>1b — Enables sampling of the ID line.</p>

10.1.5 USB_INTR_EN_R_E register

The bits in this register enable interrupts and RXCMDs to be sent when the corresponding bits in the USB_INTR_STAT register change from logic 0 to logic 1. By default, all transitions are enabled. [Table 30](#) shows the bit allocation of the register.

Table 30. USB_INTR_EN_R_E - USB Interrupt Enable Rising Edge register (address R = 0Dh to 0Fh, W = 0Dh, S = 0Eh, C = 0Fh) bit allocation

Bit	7	6	5	4	3	2	1	0
Symbol	reserved			ID_GND_R	SESS_END_R	SESS_VALID_R	VBUS_VALID_R	HOST_DISCON_R
Reset	0	0	0	1	1	1	1	1
Access	R/W/S/C	R/W/S/C	R/W/S/C	R/W/S/C	R/W/S/C	R/W/S/C	R/W/S/C	R/W/S/C

Table 31. USB_INTR_EN_R_E - USB Interrupt Enable Rising Edge register (address R = 0Dh to 0Fh, W = 0Dh, S = 0Eh, C = 0Fh) bit description

Bit	Symbol	Description
7 to 5	-	reserved
4	ID_GND_R	ID Ground Rise: Enables interrupts and RXCMDs for logic 0 to logic 1 transitions on ID_GND.
3	SESS_END_R	Session End Rise: Enables interrupts and RXCMDs for logic 0 to logic 1 transitions on SESS_END.
2	SESS_VALID_R	Session Valid Rise: Enables interrupts and RXCMDs for logic 0 to logic 1 transitions on SESS_VLD.
1	VBUS_VALID_R	V_{BUS} Valid Rise: Enables interrupts and RXCMDs for logic 0 to logic 1 transitions on VBUS_VLD.
0	HOST_DISCON_R	Host Disconnect Rise: Enables interrupts and RXCMDs for logic 0 to logic 1 transitions on HOST_DISCON.

10.1.6 USB_INTR_EN_F_E register

The bits in this register enable interrupts and RXCMDs to be sent when the corresponding bits in the USB_INTR_STAT register change from logic 1 to logic 0. By default, all transitions are enabled. See [Table 32](#).

Table 32. USB_INTR_EN_F_E - USB Interrupt Enable Falling Edge register (address R = 10h to 12h, W = 10h, S = 11h, C = 12h) bit allocation

Bit	7	6	5	4	3	2	1	0
Symbol		reserved		ID_GND_F	SESS_END_F	SESS_VALID_F	VBUS_VALID_F	HOST_DISCON_F
Reset	0	0	0	1	1	1	1	1
Access	R/W/S/C	R/W/S/C	R/W/S/C	R/W/S/C	R/W/S/C	R/W/S/C	R/W/S/C	R/W/S/C

Table 33. USB_INTR_EN_F_E - USB Interrupt Enable Falling Edge register (address R = 10h to 12h, W = 10h, S = 11h, C = 12h) bit description

Bit	Symbol	Description
7 to 5	-	reserved
4	ID_GND_F	ID Ground Fall: Enables interrupts and RXCMDs for logic 1 to logic 0 transitions on ID_GND.
3	SESS_END_F	Session End Fall: Enables interrupts and RXCMDs for logic 1 to logic 0 transitions on SESS_END.
2	SESS_VALID_F	Session Valid Fall: Enables interrupts and RXCMDs for logic 1 to logic 0 transitions on SESS_VLD.
1	VBUS_VALID_F	V_{BUS} Valid Fall: Enables interrupts and RXCMDs for logic 1 to logic 0 transitions on VBUS_VLD.
0	HOST_DISCON_F	Host Disconnect Fall: Enables interrupts and RXCMDs for logic 1 to logic 0 transitions on HOST_DISCON.

10.1.7 USB_INTR_STAT register

This register (see [Table 34](#)) indicates the current value of the interrupt source signal.

Table 34. USB_INTR_STAT - USB Interrupt Status register (address R = 13h) bit allocation

Bit	7	6	5	4	3	2	1	0
Symbol	reserved			ID_GND	SESS_END	SESS_VALID	VBUS_VALID	HOST_DISCON
Reset	X	X	X	0	0	0	0	0
Access	R	R	R	R	R	R	R	R

Table 35. USB_INTR_STAT - USB Interrupt Status register (address R = 13h) bit description

Bit	Symbol	Description
7 to 5	-	reserved
4	ID_GND	ID Ground: Reflects the current value of the ID detector circuit.
3	SESS_END	Session End: Reflects the current value of the session end voltage comparator.
2	SESS_VALID	Session Valid: Reflects the current value of the session valid voltage comparator.
1	VBUS_VALID	V_{BUS} Valid: Reflects the current value of the V _{BUS} valid voltage comparator.
0	HOST_DISCON	Host Disconnect: Reflects the current value of the host disconnect detector.

10.1.8 USB_INTR_L register

The bits of the USB_INTR_L register are automatically set by the ISP1507 when an unmasked change occurs on the corresponding interrupt source signal. The ISP1507 will automatically clear all bits when the link reads this register, or when the PHY enters low-power or serial mode.

Remark: It is optional for the link to read this register when the clock is running because all signal information will automatically be sent to the link through the RXCMD byte.

The bit allocation of this register is given in [Table 36](#).

Table 36. USB_INTR_L - USB Interrupt Latch register (address R = 14h) bit allocation

Bit	7	6	5	4	3	2	1	0
Symbol	reserved			ID_GND_L	SESS_END_L	SESS_VALID_L	VBUS_VALID_L	HOST_DISCON_L
Reset	0	0	0	0	0	0	0	0
Access	R	R	R	R	R	R	R	R

Table 37. USB_INTR_L - USB Interrupt Latch register (address R = 14h) bit description

Bit	Symbol	Description
7 to 5	-	reserved
4	ID_GND_L	ID Ground Latch: Automatically set when an unmasked event occurs on ID_GND. Cleared when this register is read.
3	SESS_END_L	Session End Latch: Automatically set when an unmasked event occurs on SESS_END. Cleared when this register is read.
2	SESS_VALID_L	Session Valid Latch: Automatically set when an unmasked event occurs on SESS_VLD. Cleared when this register is read.
1	VBUS_VALID_L	V_{BUS} Valid Latch: Automatically set when an unmasked event occurs on VBUS_VLD. Cleared when this register is read.
0	HOST_DISCON_L	Host Disconnect Latch: Automatically set when an unmasked event occurs on HOST_DISCON. Cleared when this register is read.

10.1.9 DEBUG register

The bit allocation of the DEBUG register is given in [Table 38](#). This register indicates the current value of signals useful for debugging.

Table 38. DEBUG - Debug register (address R = 15h) bit allocation

Bit	7	6	5	4	3	2	1	0
Symbol	reserved						LINE STATE1	LINE STATE0
Reset	0	0	0	0	0	0	0	0
Access	R	R	R	R	R	R	R	R

Table 39. DEBUG - Debug register (address R = 15h) bit description

Bit	Symbol	Description
7 to 2	-	reserved
1	LINESTATE1	Line State 1: Contains the current value of LINESTATE 1
0	LINESTATE0	Line State 0: Contains the current value of LINESTATE 0

10.1.10 SCRATCH register

[Table 40](#) shows the bit description of the SCRATCH register. It is an empty register for testing purposes.

Table 40. SCRATCH - Scratch register (address R = 16h to 18h, W = 16h, S = 17h, C = 18h) bit description

Legend: * reset value

Bit	Symbol	Access	Value	Description
7 to 0	SCRATCH[7:0]	R/W/S/C	00h*	Scratch: This is an empty register byte for testing purposes. Software can read, write, set and clear this register. The functionality of the PHY will not be affected.

10.1.11 Reserved

Registers 19h to 2Eh are not implemented. Operating on these addresses will have no effect on the PHY.

10.1.12 Access extended register set

Address 2Fh does not contain register data. Instead it links to the extended register set. The immediate register set maps to the lower end of the extended register set.

10.1.13 Vendor-specific registers

Addresses 30h to 3Fh contain vendor-specific registers.

10.1.14 PWR_CTRL register

This register controls various aspects of the ISP1507. [Table 41](#) shows the bit allocation of the register.

Table 41. PWR_CTRL - Power Control register (address R = 3Dh to 3Fh, W = 3Dh, S = 3Eh, C = 3Fh) bit allocation

Bit	7	6	5	4	3	2	1	0
Symbol	reserved				BVALID_FALL	BVALID_RISE	reserved	IGNORE_RESET
Reset	0	0	0	0	0	0	0	0
Access	R/W/S/C	R/W/S/C	R/W/S/C	R/W/S/C	R/W/S/C	R/W/S/C	R/W/S/C	R/W/S/C

Table 42. PWR_CTRL - Power Control register (address R = 3Dh to 3Fh, W = 3Dh, S = 3Eh, C = 3Fh) bit description

Bit	Symbol	Description
7 to 4	-	reserved; the link must never write logic 1 to these bits
3	BVALID_FALL	BVALID Fall: Enables RXCMDs for HIGH-to-LOW transitions on BVALID. When BVALID changes from HIGH to LOW, the ISP1507 will send an RXCMD to the link with the ALT_INT bit set to logic 1. This bit is optional and is not necessary for OTG devices. This bit is provided for debugging purposes. The session valid comparator must be used instead.
2	BVALID_RISE	BVALID Rise: Enables RXCMDs for LOW-to-HIGH transitions on BVALID. When BVALID changes from LOW to HIGH, the ISP1507 will send an RXCMD to the link with the ALT_INT bit set to logic 1. This bit is optional and is not necessary for OTG devices. This bit is provided for debugging purposes. The session valid comparator must be used instead.
1	-	reserved
0	IGNORE_RESET	Ignore Reset: Selects between the RESET_N and PSW_N functions of the RESET_N/PSW_N pin. The link must set this bit to logic 1 if PSW_N is used in a ganged mode configuration. 0b — The RESET_N/PSW_N pin behaves as an active-LOW reset input (RESET_N) (default). 1b — The RESET_N/PSW_N pin behaves as an active-LOW power switch output (PSW_N).

10.2 Extended register set

Addresses 00h to 3Fh of the extended register set directly map to the immediate set. This means a read, write, set or clear operation to these extended addresses will operate on the immediate register set.

Addresses 40h to FFh are not implemented. Operating on these addresses may result in undefined behavior of the PHY.

11. ElectroStatic Discharge (ESD)

11.1 ESD protection

The pins that are connected to the USB connector (DP, DM, ID, V_{BUS} and GND) have a minimum of ± 4 kV ESD protection. Capacitors 0.1 μF and 1 μF must be connected in parallel from V_{BUS} to GND to achieve this ± 4 kV ESD protection (see [Figure 21](#)).

Remark: Capacitors 0.1 μF and 1 μF are also required by *Universal Serial Bus Specification Rev. 2.0*. For details on the requirements for $C_{V_{BUS}}$, see [Section 16](#).

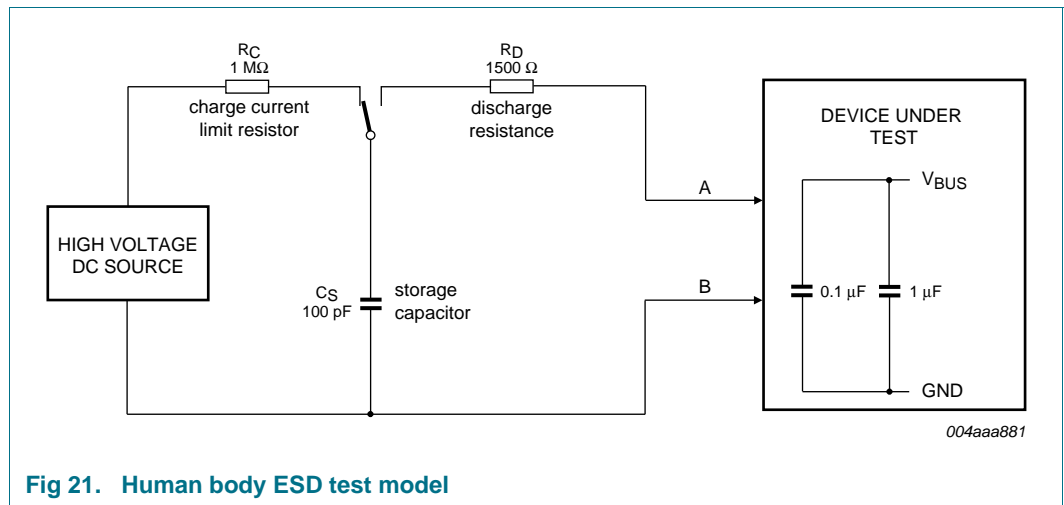

Fig 21. Human body ESD test model

11.2 ESD test conditions

A detailed report on test setup and results is available on request.

12. Limiting values

Table 43. Limiting values

In accordance with the Absolute Maximum Rating System (IEC 60134).

Symbol	Parameter	Conditions	Min	Max	Unit
V_{CC}	supply voltage		-0.5	+4.6	V
$V_{CC(I/O)}$	input/output supply voltage		-0.5	+2.5	V
V_I	input voltage	on pins STP, DATA[3:0] and RESET_N/PSW_N	-0.5	$V_{CC(I/O)} + 0.5$ ^{[1][2][3]}	V
		on pin $V_{BUS/FAULT}$	-0.5	+6.0	V
		on pin XTAL1	-0.5	+2.5	V
		on pin ID	-0.5	+4.6	V
		on pins DP and DM	^[4] -0.5	+4.6	V
V_{ESD}	electrostatic discharge voltage	pins DP, DM, ID, V_{BUS} and GND; $I_{LI} < 1 \mu A$	^[5] -4	+4	kV
		all other pins; $I_{LI} < 1 \mu A$	^[5] -1.5	+1.5	kV
I_{lu}	latch-up current	$-0.5 \times V_{CC} < V < +1.5 \times V_{CC}$	-	100	mA
T_{stg}	storage temperature		-40	+125	°C

[1] Maximum value may not exceed 2.5 V.

[2] Includes voltage on outputs in 3-state mode.

[3] Only valid when the $V_{CC(I/O)}$ supply voltage is present.

[4] The ISP1507 has been tested according to the additional requirements listed in *Universal Serial Bus Specification Rev. 2.0*, Section 7.1.1. The short circuit withstand test and the AC stress test were performed for 24 hours, and the ISP1507 was found to be fully operational after the test completed.

[5] Equivalent to discharging a 100 pF capacitor through a 1.5 k Ω resistor (Human Body Model JESD22-A114D).

13. Recommended operating conditions

Table 44. Recommended operating conditions

Symbol	Parameter	Conditions	Min	Typ	Max	Unit
V_{CC}	supply voltage		3.0	3.3	3.6	V
$V_{CC(I/O)}$	input/output supply voltage		1.65	-	1.95	V
V_I	input voltage	on pins STP, DATA[3:0] and RESET_N/PSW_N	0	-	$V_{CC(I/O)}$	V
		on pin $V_{BUS/FAULT}$	0	-	5.5	V
		on pins DP, DM and ID	0	-	3.6	V
		on pin XTAL1	0	-	1.95	V
T_{amb}	ambient temperature		-40	+25	+85	°C
T_j	junction temperature		-40	-	+125	°C

14. Static characteristics

Table 45. Static characteristics: supply pins

$V_{CC} = 3.0\text{ V to }3.6\text{ V}$; $V_{CC(I/O)} = 1.65\text{ V to }1.95\text{ V}$; $T_{amb} = -40\text{ }^{\circ}\text{C to }+85\text{ }^{\circ}\text{C}$; unless otherwise specified.

Typical values are at $V_{CC} = 3.3\text{ V}$; $V_{CC(I/O)} = 1.8\text{ V}$; $T_{amb} = +25\text{ }^{\circ}\text{C}$; unless otherwise specified.

Symbol	Parameter	Conditions	Min	Typ	Max	Unit	
$V_{(REG3V3)}$	voltage on pin REG3V3		3.0	3.3	3.6	V	
$V_{(REG1V8)}$	voltage on pin REG1V8		1.65	1.8	1.95	V	
$V_{POR(trip)}$	power-on reset trip voltage		1.0	-	1.5	V	
I_{CC}	supply current	charge pump disabled					
		low-power mode; V_{BUS} valid detector disabled; 1.5 k Ω pull-up resistor on pin DP disconnected	-	30	85	μA	
		low-power mode; V_{BUS} valid detector disabled; 1.5 k Ω pull-up resistor on pin DP connected	-	210	280	μA	
		full-speed continuous data transmit; 50 pF load on pins DP and DM	[1]	-	15	-	mA
		full-speed continuous data receive	[1]	-	11	-	mA
		high-speed continuous data transmit; 45 Ω load on pins DP and DM to ground	[1]	-	48	-	mA
		high-speed continuous data receive	[1]	-	28	-	mA
		charge pump enabled					
		$I_{O(VBUS)} = 8\text{ mA}$; charge pump supply current only	-	20	23	mA	
$I_{CC(I/O)}$	supply current on pin $V_{CC(I/O)}$	ULPI pins are static	-	-	1	μA	
		$I_{O(VBUS)} = 0\text{ mA}$; charge pump supply current only	-	300	-	μA	

[1] A continuous stream of 1 kB packets with minimum inter-packet gap and all data bits set to logic 0 for continuous toggling.

Table 46. Static characteristics: digital pins (CLOCK, DIR, STP, NXT, DATA[3:0], RESET_N/PSW_N)

$V_{CC} = 3.0\text{ V to }3.6\text{ V}$; $V_{CC(I/O)} = 1.65\text{ V to }1.95\text{ V}$; $T_{amb} = -40\text{ }^{\circ}\text{C to }+85\text{ }^{\circ}\text{C}$; unless otherwise specified.

Typical values are at $V_{CC} = 3.3\text{ V}$; $V_{CC(I/O)} = 1.8\text{ V}$; $T_{amb} = +25\text{ }^{\circ}\text{C}$; unless otherwise specified.

Symbol	Parameter	Conditions	Min	Typ	Max	Unit
Input levels						
V_{IL}	LOW-level input voltage		-	-	$0.25 \times V_{CC(I/O)}$	V
V_{IH}	HIGH-level input voltage		$0.8 \times V_{CC(I/O)}$	-	-	V
I_{IL}	LOW-level input current	$V_I = 0\text{ V}$	-	-	1	μA
I_{IH}	HIGH-level input current	$V_I = V_{CC(I/O)}$	-	-	1	μA
I_{LI}	input leakage current		-1	+0.1	+1	μA
Output levels						
V_{OL}	LOW-level output voltage	$I_{OL} = +4\text{ mA}$	-	-	0.4	V
V_{OH}	HIGH-level output voltage	$I_{OH} = -4\text{ mA}$	$V_{CC(I/O)} - 0.4$	-	-	V
I_{OH}	HIGH-level output current	$V_{OH} = V_{CC(I/O)} - 0.4\text{ V}$	-4	-	-	mA
I_{OL}	LOW-level output current	$V_{OL} = 0.4\text{ V}$	+4	-	-	mA

Table 46. Static characteristics: digital pins (CLOCK, DIR, STP, NXT, DATA[3:0], RESET_N/PSW_N) ...continued

$V_{CC} = 3.0\text{ V to }3.6\text{ V}$; $V_{CC(I/O)} = 1.65\text{ V to }1.95\text{ V}$; $T_{amb} = -40\text{ }^{\circ}\text{C to }+85\text{ }^{\circ}\text{C}$; unless otherwise specified.

Typical values are at $V_{CC} = 3.3\text{ V}$; $V_{CC(I/O)} = 1.8\text{ V}$; $T_{amb} = +25\text{ }^{\circ}\text{C}$; unless otherwise specified.

Symbol	Parameter	Conditions	Min	Typ	Max	Unit
I_{OZ}	off-state output current	$0\text{ V} < V_O < V_{CC(I/O)}$	-	-	1	μA
Impedance						
Z_L	load impedance		40	-	75	Ω
Pull-up and pull-down						
I_{pd}	pull-down current	interface protect enabled; DATA[3:0] pins only; $V_I = V_{CC(I/O)}$	25	50	90	μA
I_{pu}	pull-up current	interface protect enabled; STP pin only; $V_I = 0\text{ V}$	-30	-50	-75	μA
Capacitance						
C_{in}	input capacitance	pins STP, RESET_N, CLOCK, DATA[3:0]	-	-	3.5	pF

Table 47. Static characteristics: digital pin FAULT

$V_{CC} = 3.0\text{ V to }3.6\text{ V}$; $V_{CC(I/O)} = 1.65\text{ V to }1.95\text{ V}$; $T_{amb} = -40\text{ }^{\circ}\text{C to }+85\text{ }^{\circ}\text{C}$; unless otherwise specified.

Symbol	Parameter	Conditions	Min	Typ	Max	Unit
Input levels						
V_{IL}	LOW-level input voltage		-	-	0.8	V
V_{IH}	HIGH-level input voltage		2.0	-	-	V
I_{IL}	LOW-level input current	$V_I = 0\text{ V}$	-	-	1	μA
I_{IH}	HIGH-level input current	$V_I = V_{CC(I/O)}$	-	-	1	μA

Table 48. Static characteristics: analog I/O pins (DP, DM)

$V_{CC} = 3.0\text{ V to }3.6\text{ V}$; $V_{CC(I/O)} = 1.65\text{ V to }1.95\text{ V}$; $T_{amb} = -40\text{ }^{\circ}\text{C to }+85\text{ }^{\circ}\text{C}$; unless otherwise specified.

Typical values are at $V_{CC} = 3.3\text{ V}$; $V_{CC(I/O)} = 1.8\text{ V}$; $T_{amb} = +25\text{ }^{\circ}\text{C}$; unless otherwise specified.

Symbol	Parameter	Conditions	Min	Typ	Max	Unit
Original USB transceiver (low-speed and full-speed)						
Input levels (differential receiver)						
V_{DI}	differential input sensitivity voltage	$ V_{DP} - V_{DM} $	0.2	-	-	V
V_{CM}	differential common mode voltage range	includes V_{DI} range	0.8	-	2.5	V
Input levels (single-ended receivers)						
V_{IL}	LOW-level input voltage		-	-	0.8	V
V_{IH}	HIGH-level input voltage		2.0	-	-	V
Output levels						
V_{OL}	LOW-level output voltage	pull-up on pin DP; $R_L = 1.5\text{ k}\Omega\text{ to }3.6\text{ V}$	0.0	0.18	0.3	V
V_{OH}	HIGH-level output voltage	pull-down on pins DP and DM; $R_L = 15\text{ k}\Omega\text{ to }GND$	2.8	3.2	3.6	V

Table 48. Static characteristics: analog I/O pins (DP, DM) ...continued

$V_{CC} = 3.0\text{ V to }3.6\text{ V}$; $V_{CC(I/O)} = 1.65\text{ V to }1.95\text{ V}$; $T_{amb} = -40\text{ °C to }+85\text{ °C}$; unless otherwise specified.

Typical values are at $V_{CC} = 3.3\text{ V}$; $V_{CC(I/O)} = 1.8\text{ V}$; $T_{amb} = +25\text{ °C}$; unless otherwise specified.

Symbol	Parameter	Conditions	Min	Typ	Max	Unit
Termination						
V_{TERM}	termination voltage for upstream facing port pull-up	for 1.5 k Ω pull-up resistor	3.0	-	3.6	V
Resistance						
$R_{UP(DP)}$	pull-up resistance on pin DP		1425	1500	1575	Ω
High-speed USB transceiver						
Input levels (differential receiver)						
V_{HSSQ}	high-speed squelch detection threshold voltage (differential signal amplitude)		100	-	150	mV
V_{HSDSC}	high-speed disconnect detection threshold voltage (differential signal amplitude)		525	-	625	mV
V_{HSDI}	high-speed differential input sensitivity	$ V_{DP} - V_{DM} $	100	-	-	mV
V_{HSCM}	high-speed data signaling common mode voltage range (guideline for receiver)	includes V_{DI} range	-50	-	+500	mV
V_{HSOI}	high-speed idle level voltage		-10	-	+10	mV
V_{HSOL}	high-speed data signaling LOW-level voltage		-10	-	+10	mV
Output levels						
V_{HSOH}	high-speed data signaling HIGH-level voltage		360	-	440	mV
V_{CHIRPJ}	Chirp J level (differential voltage)		700	-	1100	mV
V_{CHIRPK}	Chirp K level (differential voltage)		-900	-	-500	mV
Leakage current						
I_{LZ}	off-state leakage current		-1	-	+1	μA
Capacitance						
C_{in}	input capacitance	pin to GND	-	-	5	pF
Resistance						
$R_{DN(DP)}$	pull-down resistance on pin DP		14.25	15	15.75	k Ω
$R_{DN(DM)}$	pull-down resistance on pin DM		14.25	15	15.75	k Ω
Termination						
$Z_{O(drv)(DP)}$	driver output impedance on pin DP	steady-state drive	[1] 40.5	45	49.5	Ω
$Z_{O(drv)(DM)}$	driver output impedance on pin DM	steady-state drive	[1] 40.5	45	49.5	Ω
Z_{INP}	input impedance exclusive of pull-up/pull-down (for low-/full-speed)		10	-	-	M Ω

[1] For high-speed USB and full-speed USB.

Table 49. Static characteristics: charge pump

$V_{CC} = 3.0\text{ V to }3.6\text{ V}$; $V_{CC(I/O)} = 1.65\text{ V to }1.95\text{ V}$; $T_{amb} = -40\text{ }^{\circ}\text{C to }+85\text{ }^{\circ}\text{C}$; unless otherwise specified.
 Typical values are at $V_{CC} = 3.3\text{ V}$; $V_{CC(I/O)} = 1.8\text{ V}$; $T_{amb} = +25\text{ }^{\circ}\text{C}$; unless otherwise specified.

Symbol	Parameter	Conditions	Min	Typ	Max	Unit
Voltage						
$V_{O(VBUS)}$	output voltage on pin V_{BUS}	$I_{O(VBUS)} = 50\text{ mA}$; $C_{cp(C_A)-(C_B)} = 270\text{ nF}$	4.65	5.0	5.25	V
$V_{L(VBUS)}$	leakage voltage on pin V_{BUS}	charge pump disabled	-	-	0.2	V
Current						
$I_{O(VBUS)}$	output current on pin V_{BUS}	$C_{cp(C_A)-(C_B)} = 270\text{ nF}$	45	75	-	mA
Efficiency						
η_{cp}	charge pump efficiency	$I_{O(VBUS)} = 50\text{ mA}$	60	72	78	%

Table 50. Static characteristics: V_{BUS} comparators

$V_{CC} = 3.0\text{ V to }3.6\text{ V}$; $V_{CC(I/O)} = 1.65\text{ V to }1.95\text{ V}$; $T_{amb} = -40\text{ }^{\circ}\text{C to }+85\text{ }^{\circ}\text{C}$; unless otherwise specified.
 Typical values are at $V_{CC} = 3.3\text{ V}$; $V_{CC(I/O)} = 1.8\text{ V}$; $T_{amb} = +25\text{ }^{\circ}\text{C}$; unless otherwise specified.

Symbol	Parameter	Conditions	Min	Typ	Max	Unit
$V_{A_VBUS_VLD}$	A-device V_{BUS} valid voltage		4.4	4.5	4.65	V
$V_{A_SESS_VLD}$	A-device session valid voltage	for A-device and B-device	0.8	1.6	2.0	V
$V_{hys(A_SESS_VLD)}$	A-device session valid hysteresis voltage		70	90	120	mV
$V_{B_SESS_END}$	B-device session end voltage		0.2	0.5	0.8	V

Table 51. Static characteristics: V_{BUS} resistors

$V_{CC} = 3.0\text{ V to }3.6\text{ V}$; $V_{CC(I/O)} = 1.65\text{ V to }1.95\text{ V}$; $T_{amb} = -40\text{ }^{\circ}\text{C to }+85\text{ }^{\circ}\text{C}$; unless otherwise specified.
 Typical values are at $V_{CC} = 3.3\text{ V}$; $V_{CC(I/O)} = 1.8\text{ V}$; $T_{amb} = +25\text{ }^{\circ}\text{C}$; unless otherwise specified.

Symbol	Parameter	Conditions	Min	Typ	Max	Unit
$R_{UP(VBUS)}$	pull-up resistance on pin V_{BUS}	connect to REG3V3 when CHRG_VBUS is logic 1	281	680	-	Ω
$R_{DN(VBUS)}$	pull-down resistance on pin V_{BUS}	connect to GND when DISCHRG_VBUS is logic 1	656	1100	-	Ω
$R_{I(idle)(VBUS)(A)}$	idle input resistance on pin V_{BUS} (A-device)	ID pin LOW and charge pump disabled	40	54	80	k Ω
$R_{I(idle)(VBUS)(B)}$	idle input resistance on pin V_{BUS} (B-device)	ID pin HIGH or charge pump enabled	170	230	310	k Ω

Table 52. Static characteristics: ID detection circuit

$V_{CC} = 3.0\text{ V to }3.6\text{ V}$; $V_{CC(I/O)} = 1.65\text{ V to }1.95\text{ V}$; $T_{amb} = -40\text{ }^{\circ}\text{C to }+85\text{ }^{\circ}\text{C}$; unless otherwise specified.
 Typical values are at $V_{CC} = 3.3\text{ V}$; $V_{CC(I/O)} = 1.8\text{ V}$; $T_{amb} = +25\text{ }^{\circ}\text{C}$; unless otherwise specified.

Symbol	Parameter	Conditions	Min	Typ	Max	Unit
t_{ID}	ID detection time		50	-	-	ms
$V_{th(ID)}$	ID detector threshold voltage		0.8	1.2	2.0	V
$R_{UP(ID)}$	ID pull-up resistance	ID_PULLUP is logic 1	40	50	60	k Ω

Table 53. Static characteristics: resistor reference

$V_{CC} = 3.0\text{ V to }3.6\text{ V}$; $V_{CC(I/O)} = 1.65\text{ V to }1.95\text{ V}$; $T_{amb} = -40\text{ }^{\circ}\text{C to }+85\text{ }^{\circ}\text{C}$; unless otherwise specified.

Typical values are at $V_{CC} = 3.3\text{ V}$; $V_{CC(I/O)} = 1.8\text{ V}$; $T_{amb} = +25\text{ }^{\circ}\text{C}$; unless otherwise specified.

Symbol	Parameter	Conditions	Min	Typ	Max	Unit
$V_{O(RREF)}$	output voltage on pin RREF	SUSPENDM is logic 1	-	1.22	-	V

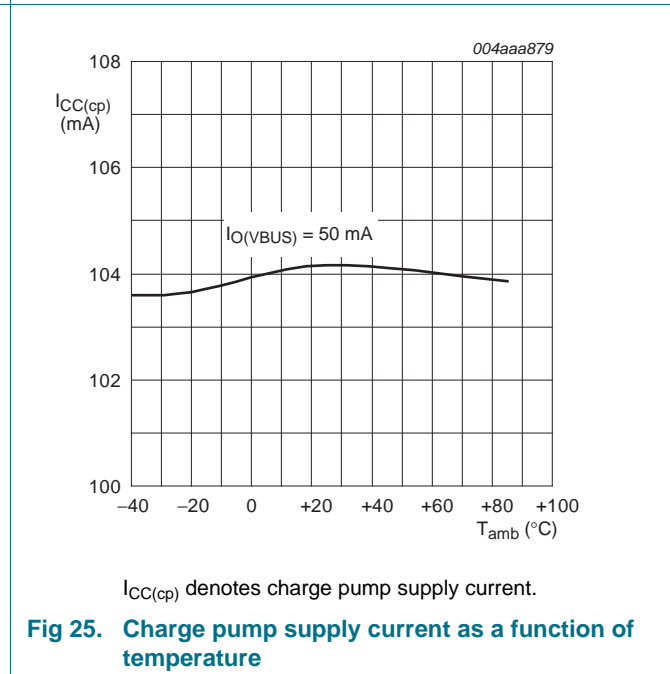
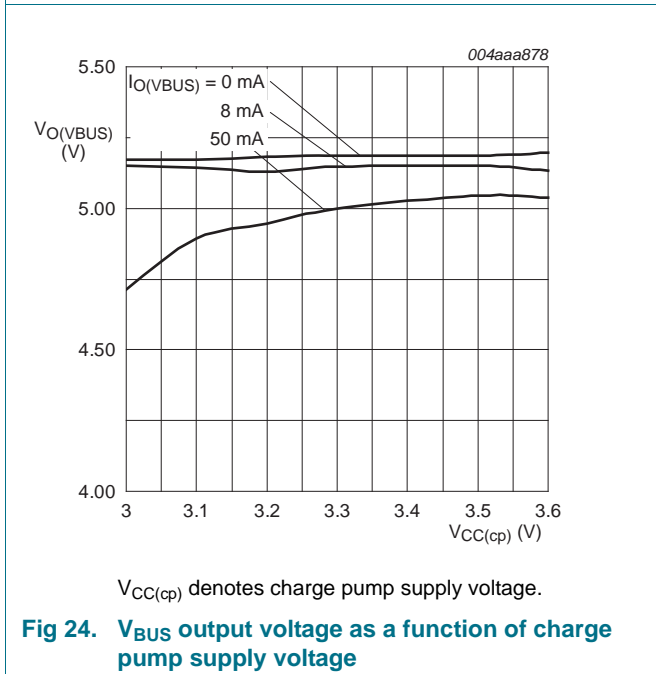
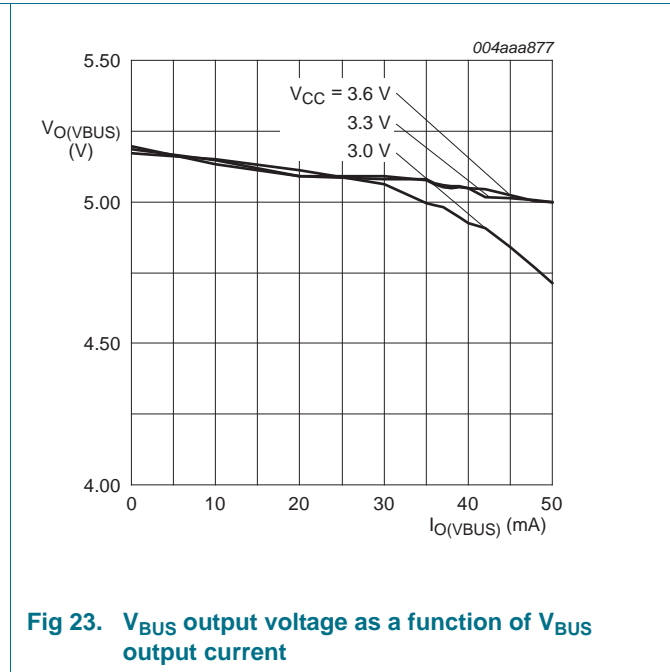
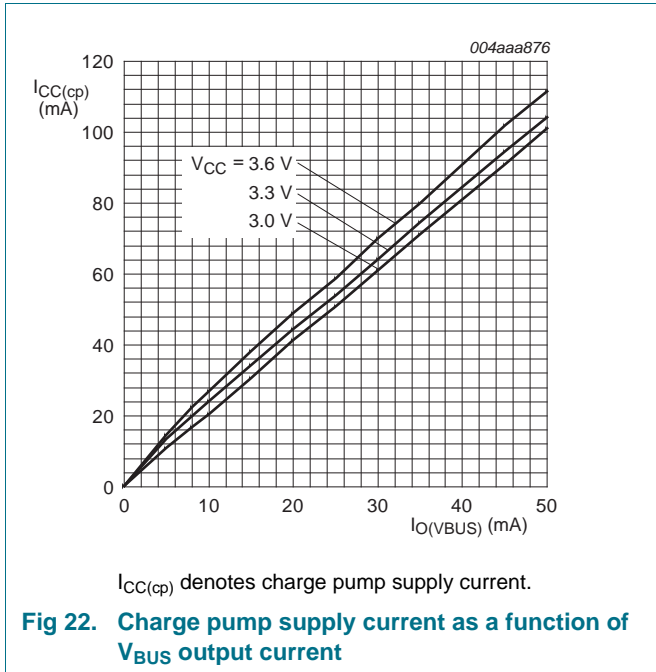

15. Dynamic characteristics

Table 54. Dynamic characteristics: reset and clock

$V_{CC} = 3.0\text{ V to }3.6\text{ V}$; $V_{CC(I/O)} = 1.65\text{ V to }1.95\text{ V}$; $T_{amb} = -40\text{ °C to }+85\text{ °C}$; unless otherwise specified.

Typical values are at $V_{CC} = 3.3\text{ V}$; $V_{CC(I/O)} = 1.8\text{ V}$; $T_{amb} = +25\text{ °C}$; unless otherwise specified.

Symbol	Parameter	Conditions	Min	Typ	Max	Unit
Reset						
$t_{W(POR)}$	internal power-on reset pulse width		0.2	-	-	μs
$t_{W(REG1V8_H)}$	REG1V8 HIGH pulse width		2	-	-	μs
$t_{W(REG1V8_L)}$	REG1V8 LOW pulse width		11	-	-	μs
$t_{W(RESET_N)}$	external RESET_N pulse width		200	-	-	ns
t_{REGUP}	regulator start-up time	4.7 $\mu\text{F} \pm 20\%$ capacitor each on pins REG1V8 and REG3V3				
		$V_{CC} = 3.3\text{ V}$; $T_{amb} = +25\text{ °C}$	-	2	-	ms
		$V_{CC} = 3.0\text{ V}$; $T_{amb} = -40\text{ °C}$	-	-	50	ms
Crystal or clock applied to XTAL1						
$f_{i(XTAL1)}$	input frequency on pin XTAL1	ISP1507E	-	19.2	-	MHz
		ISP1507F	-	26	-	MHz
$t_{jit(i)(XTAL1)RMS}$	RMS input jitter on pin XTAL1	ISP1507E	-	-	200	ps
		ISP1507F	-	-	300	ps
$\delta_{i(XTAL1)}$	input duty cycle on pin XTAL1	applicable only when clock is applied on pin XTAL1 [1]	-	50	-	%
$\Delta f_{i(XTAL1)}$	input frequency tolerance on pin XTAL1		-	50	200	ppm
$t_{r(XTAL1)}$	rise time on pin XTAL1	only for square wave input	-	-	5	ns
$t_{f(XTAL1)}$	fall time on pin XTAL1	only for square wave input	-	-	5	ns
$V_{(XTAL1)(p-p)}$	peak-to-peak voltage on pin XTAL1	only for square wave input	0.566	-	1.95	V
Output CLOCK characteristics						
$f_{o(CLOCK)}$	output frequency on pin CLOCK		-	60	-	MHz
$t_{jit(o)(CLOCK)RMS}$	RMS output jitter on pin CLOCK		-	-	500	ps
$\delta_{o(CLOCK)}$	output clock duty cycle on pin CLOCK		45	50	55	%
$t_{startup(PLL)}$	PLL startup time		-	650	-	μs
$t_{startup(o)(CLOCK)}$	output CLOCK start-up time	measured from power good or assertion of pin STP	450	650	900	μs

[1] The internal PLL is triggered only on the positive edge from the crystal oscillator. Therefore, the duty cycle is not critical.

Table 55. Dynamic characteristics: digital I/O pins

$V_{CC} = 3.0\text{ V to }3.6\text{ V}$; $V_{CC(I/O)} = 1.65\text{ V to }1.95\text{ V}$; $T_{amb} = -40\text{ }^{\circ}\text{C to }+85\text{ }^{\circ}\text{C}$; unless otherwise specified.

Symbol	Parameter	Conditions	Min	Typ	Max	Unit
$t_{su(DATA)}$	DATA set-up time with respect to the rising edge of pin CLOCK	20 pF total external load per pin	3.1 ^[1]	-	-	ns
$t_{h(DATA)}$	DATA hold time with respect to the rising edge of pin CLOCK	20 pF total external load per pin	0	-	-	ns
$t_{d(DATA)}$	DATA output delay with respect to the rising edge of pin CLOCK	20 pF total external load per pin	-	-	5.2 ^[1]	ns
$t_{su(STP)}$	STP set-up time with respect to the rising edge of pin CLOCK	20 pF total external load per pin	4.7	-	-	ns
$t_{h(STP)}$	STP hold time with respect to the rising edge of pin CLOCK	20 pF total external load per pin	0	-	-	ns
$t_{d(DIR)}$	DIR output delay with respect to the rising edge of pin CLOCK	20 pF total external load per pin	-	-	8.7	ns
$t_{d(NXT)}$	NXT output delay with respect to the rising edge of pin CLOCK	20 pF total external load per pin	-	-	8.7	ns

[1] Note that the value exceeds that specified in *UTMI+ Low Pin Interface (ULPI) Specification Rev. 1.1*.

Table 56. Dynamic characteristics: analog I/O pins (DP and DM)

$V_{CC} = 3.0\text{ V to }3.6\text{ V}$; $V_{CC(I/O)} = 1.65\text{ V to }1.95\text{ V}$; $T_{amb} = -40\text{ }^{\circ}\text{C to }+85\text{ }^{\circ}\text{C}$; unless otherwise specified.

Symbol	Parameter	Conditions	Min	Typ	Max	Unit
High-speed driver						
t_{HSR}	rise time (10 % to 90 %)		500	-	-	ps
t_{HSF}	fall time (10 % to 90 %)		500	-	-	ps
Full-speed driver						
t_{FR}	rise time	$C_L = 50\text{ pF}$; 10 % to 90 % of $ V_{OH} - V_{OL} $	4	-	20	ns
t_{FF}	fall time	$C_L = 50\text{ pF}$; 10 % to 90 % of $ V_{OH} - V_{OL} $	4	-	20	ns
t_{FRFM}	differential rise and fall time matching	excluding the first transition from the idle state	90	-	111.1	%
V_{CRS}	output signal crossover voltage	excluding the first transition from the idle state	1.3	-	2.0	V
Low-speed driver						
t_{LR}	transition time: rise time	$C_L = 200\text{ pF to }600\text{ pF}$; 1.5 k Ω pull-up on pin DM enabled; 10 % to 90 % of $ V_{OH} - V_{OL} $	75	-	300	ns
t_{LF}	transition time: fall time	$C_L = 200\text{ pF to }600\text{ pF}$; 1.5 k Ω pull-up on pin DM enabled; 10 % to 90 % of $ V_{OH} - V_{OL} $	75	-	300	ns
t_{LRFM}	rise and fall time matching	t_{LR}/t_{LF} ; excluding the first transition from the idle state	80	-	125	%
Driver timing						
$t_{PLH(drv)}$	driver propagation delay (LOW to HIGH)	DAT, SE0 to DP, DM; see Figure 27	-	-	20	ns
$t_{PHL(drv)}$	driver propagation delay (HIGH to LOW)	DAT, SE0 to DP, DM; see Figure 27	-	-	20	ns

Table 56. Dynamic characteristics: analog I/O pins (DP and DM) ...continued

$V_{CC} = 3.0\text{ V to }3.6\text{ V}$; $V_{CC(I/O)} = 1.65\text{ V to }1.95\text{ V}$; $T_{amb} = -40\text{ }^{\circ}\text{C to }+85\text{ }^{\circ}\text{C}$; unless otherwise specified.

Symbol	Parameter	Conditions	Min	Typ	Max	Unit
t_{PHZ}	driver disable delay from HIGH level	TX_ENABLE to DP, DM; see Figure 28	-	-	12	ns
t_{PLZ}	driver disable delay from LOW level	TX_ENABLE to DP, DM; see Figure 28	-	-	12	ns
t_{PZH}	driver enable delay to HIGH level	TX_ENABLE to DP, DM; see Figure 28	-	-	20	ns
t_{PZL}	driver enable delay to LOW level	TX_ENABLE to DP, DM; see Figure 28	-	-	20	ns

Receiver timing

Differential receiver

$t_{PLH(rcv)}$	receiver propagation delay (LOW to HIGH)	DP, DM to DAT, SE0; see Figure 29	-	-	20	ns
$t_{PHL(rcv)}$	receiver propagation delay (HIGH to LOW)	DP, DM to DAT, SE0; see Figure 29	-	-	20	ns

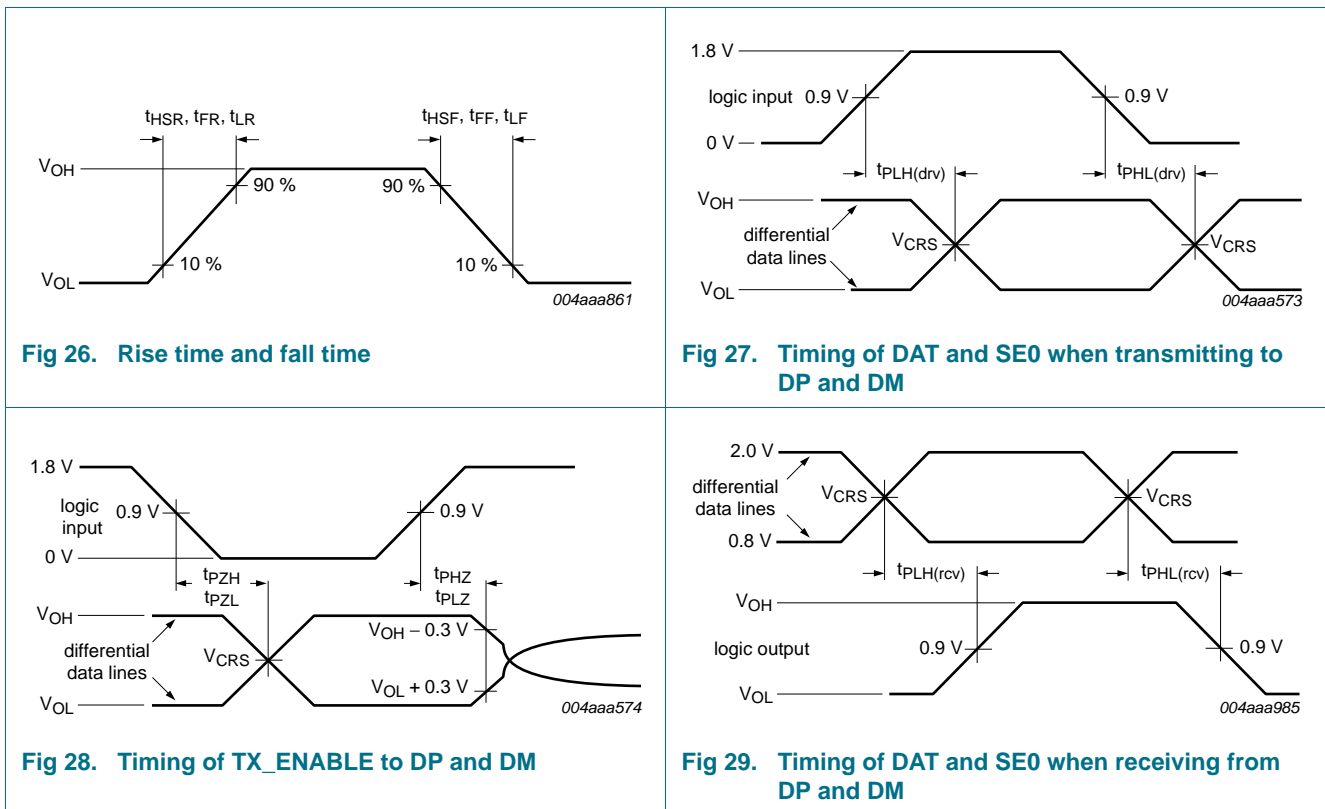

15.1 ULPI timing

ULPI timing requirements are given in [Figure 30](#). This timing applies to synchronous mode only. All timing is measured with respect to the ISP1507 CLOCK pin. All signals are clocked on the rising and falling edges of CLOCK.

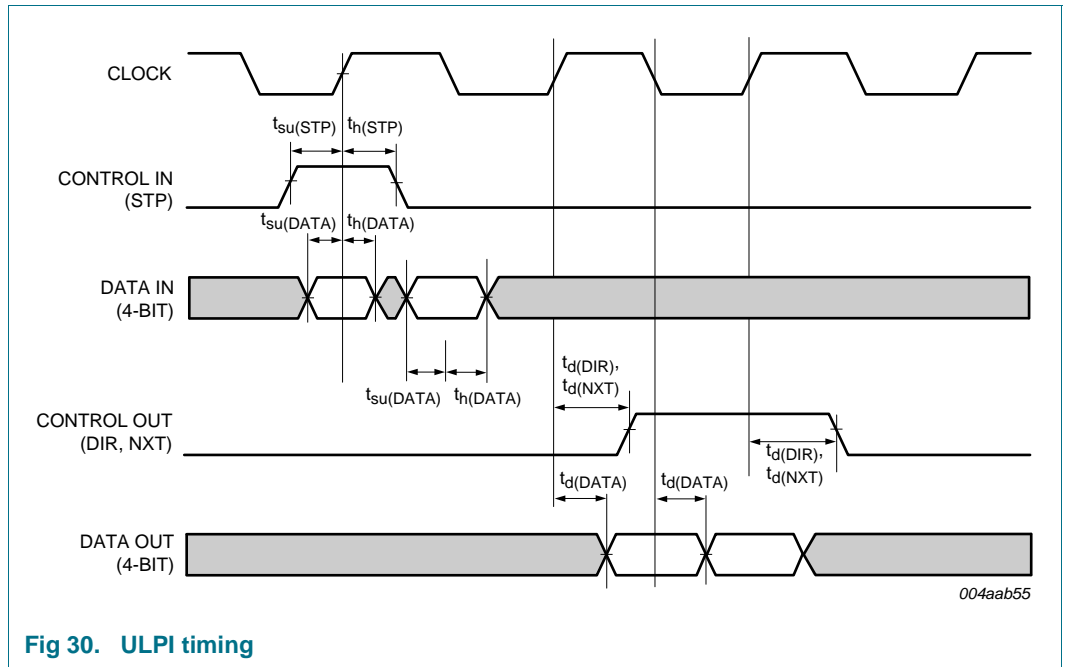

Fig 30. ULPI timing

16. Application information

Table 57. Recommended list of materials

Designator ^[1]	Application	Value	Comment
C _{bypass}	highly recommended for all applications	0.1 μF	-
C _{cp(C_A)-(C_B)}	charge pump is used	22 nF (8 mA), 270 nF (50 mA); up to 470 nF (50 mA)	-
C _{filter}	highly recommended for all applications	4.7 μF ± 20 %; use a LOW ESR capacitor (0.2 Ω to 2 Ω) for best performance	-
C _{VBUS}	mandatory for peripherals	0.1 μF and 1 μF to 10 μF in parallel	-
	mandatory for host	0.1 μF and 120 μF ± 20 % (min) in parallel	-
	mandatory for OTG	0.1 μF and 1 μF to 6.5 μF in parallel	-
R _{pullup}	recommended; for applications with an external V _{BUS} supply controlled by PSW_N	4.7 kΩ (recommended)	maximum value is determined by the voltage drop on PSW_N caused by leakage into PSW_N and the external supply control pin
R _{REF}	mandatory in all applications	12 kΩ ± 1 %	-
R _{VBUS}	strongly recommended for peripheral or external 5 V applications only	1 kΩ ± 5 %	-
R _{XTAL}	required only for applications driving a square wave into the XTAL1 pin	47 kΩ ± 5 %	used to avoid floating input on the XTAL1 pin
XTAL	crystal is used	19.2 MHz	C _L = 10 pF; R _S < 220 Ω; C _{XTAL} = 18 pF
		26 MHz	C _L = 10 pF; R _S < 130 Ω; C _{XTAL} = 18 pF
C _{(XTAL)SQ}	required only for applications driving a square wave into the XTAL1 pin that has a DC offset	100 pF	used to AC couple the input square wave to the XTAL1 pin
D _{VBUS}	recommended for all OTG applications	-	STPS0520Z; Schottky rectifier Remark: Adding Schottky diode will bring down the V _{BUS} voltage by 0.2 V to 0.25 V, depending on the load current. However, it is still within the requirement of <i>Universal Serial Bus Specification Rev. 2.0</i> .

[1] For detailed information, refer to application note *Interfacing to the ISP1507 (AN10080)*.

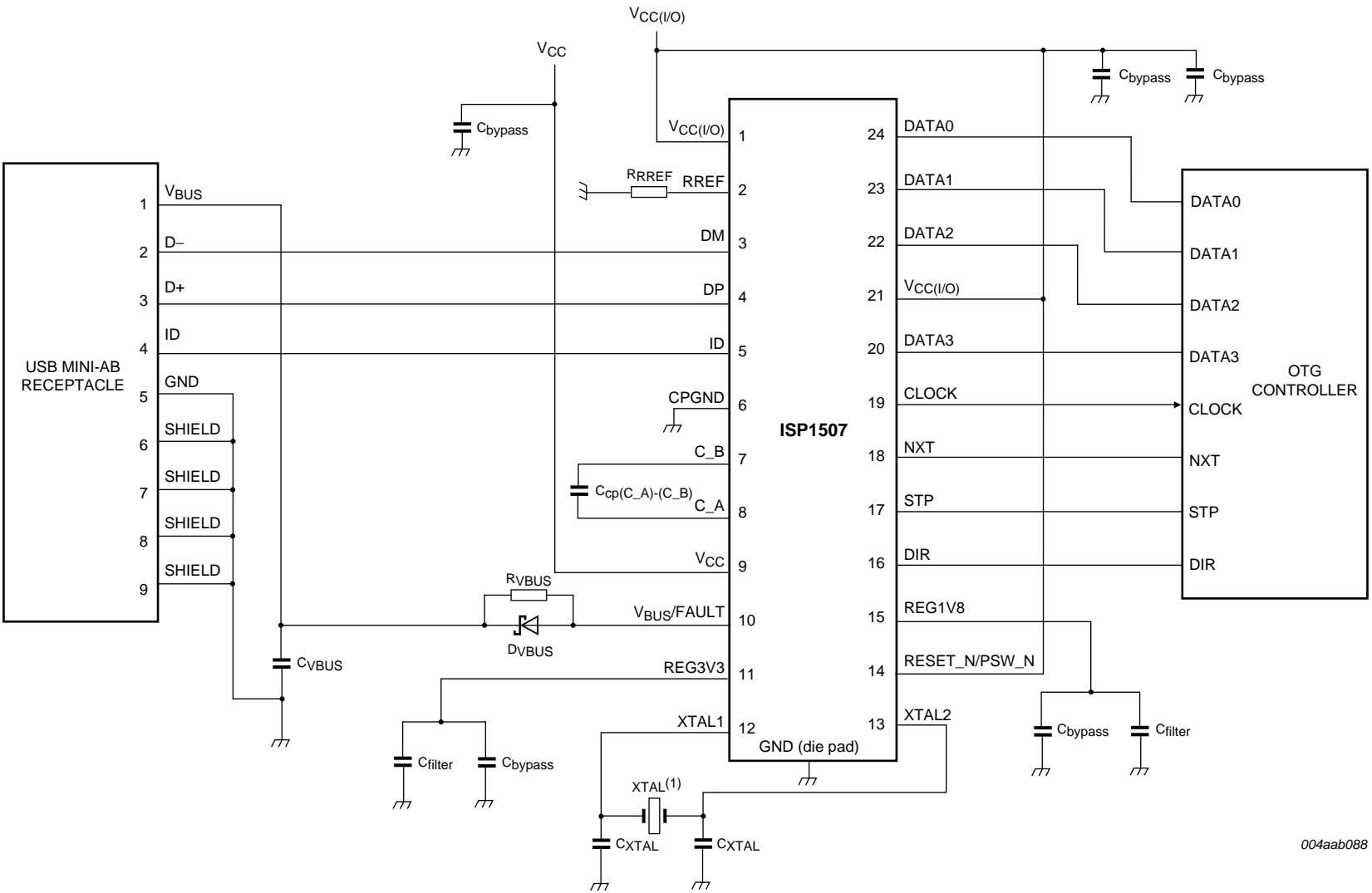

004aab088

(1) Frequency is version dependent: ISP1507E: 19.2 MHz; ISP1507F: 26 MHz.

Fig 31. Using the ISP1507 with an OTG controller; internal charge pump is utilized and crystal is attached

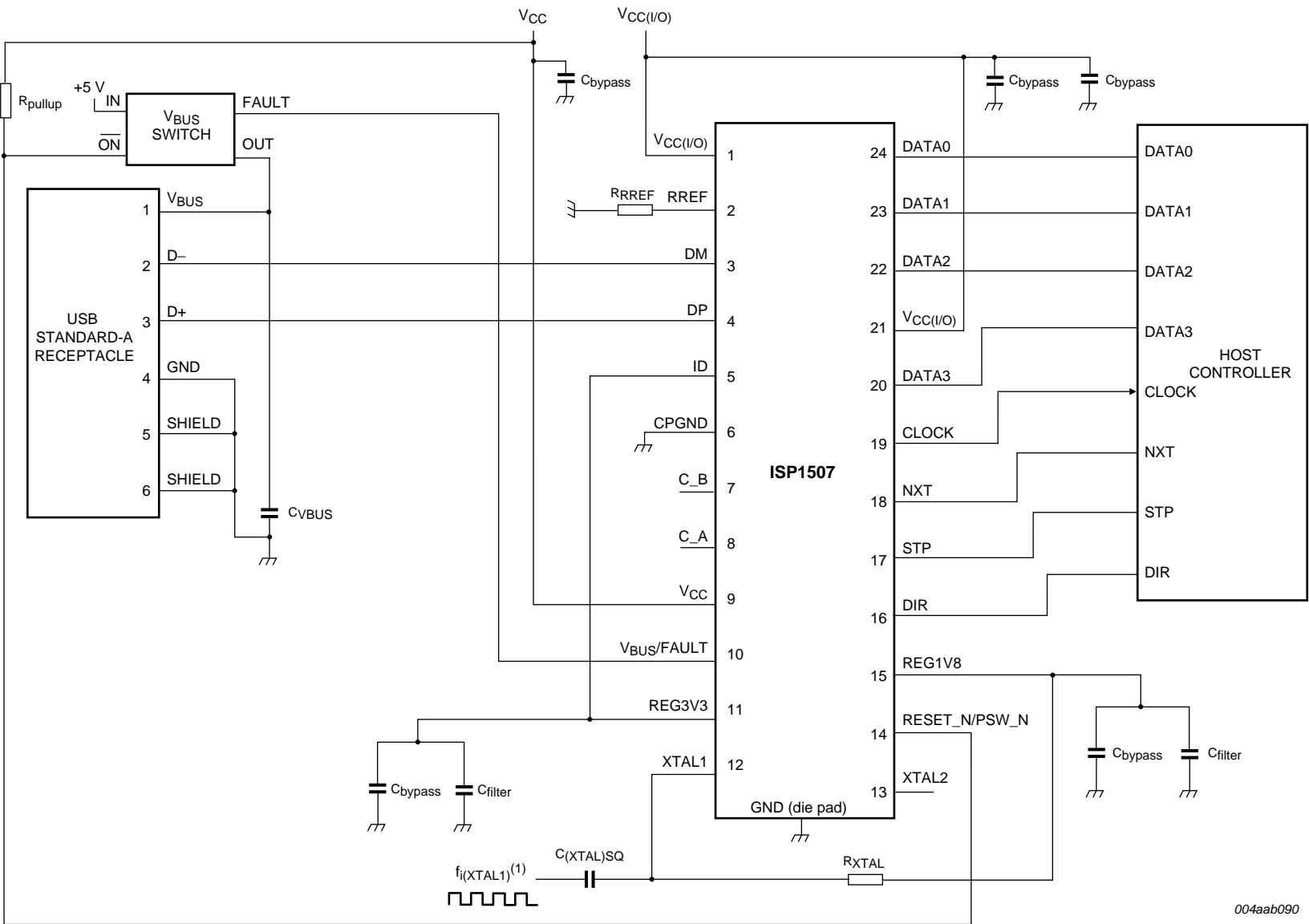

004aab090

(1) Frequency is version dependent: ISP1507E: 19.2 MHz; ISP1507F: 26 MHz.

Fig 33. Using the ISP1507 with a standard USB host controller; external 5 V source with built-in FAULT and external square wave input on XTAL1

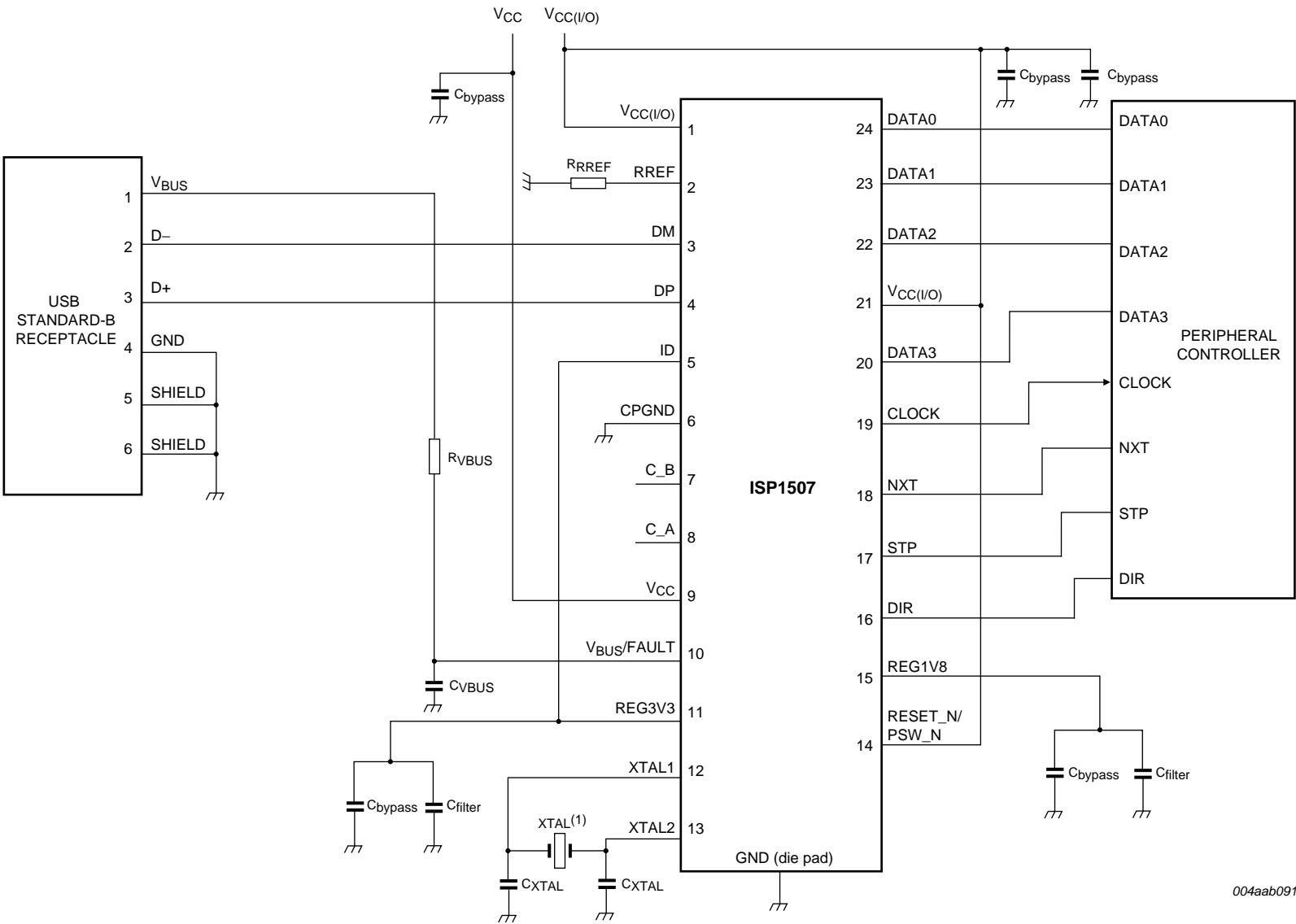

004aab091

(1) Frequency is version dependent: ISP1507E: 19.2 MHz; ISP1507F: 26 MHz.

Fig 34. Using the ISP1507 with a standard USB peripheral controller; external crystal is used

17. Package outline

HVQFN24: plastic thermal enhanced very thin quad flat package; no leads;
24 terminals; body 4 x 4 x 0.85 mm

SOT616-3

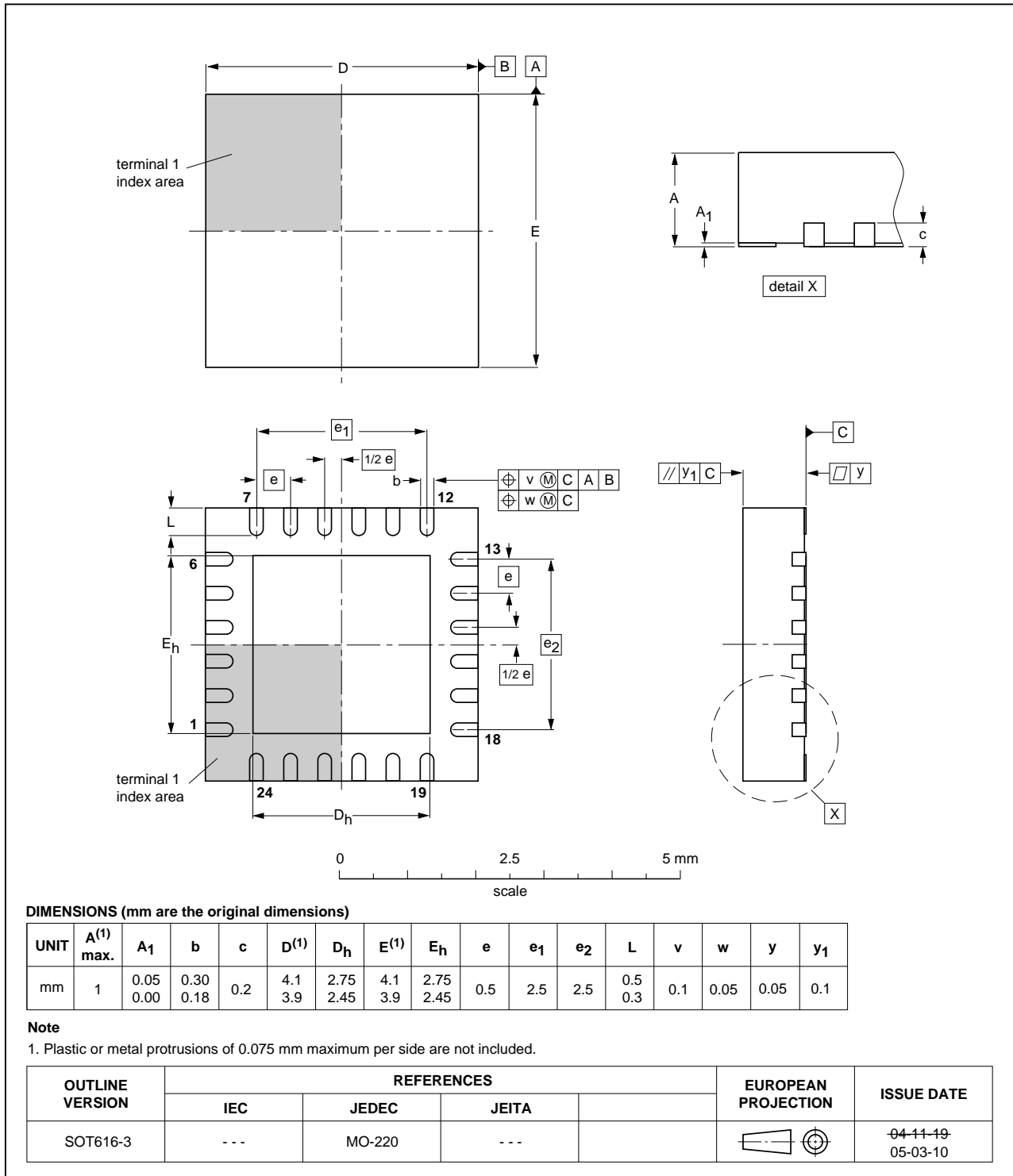

Fig 35. Package outline SOT616-3 (HVQFN24)

18. Abbreviations

Table 58. Abbreviations

Acronym	Description
ASIC	Application-Specific Integrated Circuit
ATX	Analog USB Transceiver
CD-RW	Compact Disc-ReWritable
EOP	End-Of-Packet
ESD	ElectroStatic Discharge
ESR	Effective Series Resistance
FS	Full-Speed
HBM	Human Body Model
HNP	Host Negotiation Protocol
HS	High-Speed
ID	Identification
IEC	International Electrotechnical Commission
LS	Low-Speed
NRZI	Non-Return-to-Zero Inverted
OTG	On-The-Go
PCB	Printed-Circuit Board
PHY	Physical Layer
PID	Packet Identifier
PLD	Programmable Logic Device
PLL	Phase-Locked Loop
POR	Power-On Reset
RXCMD	Receive Command
SE0	Single-Ended Zero
SOF	Start-Of-Frame
SRP	Session Request Protocol
SYNC	Synchronous
TTL	Transistor-Transistor Logic
TXCMD	Transmit Command
ULPI	UTMI+ Low Pin Interface
USB	Universal Serial Bus
USB-IF	USB Implementers Forum
UTMI	USB 2.0 Transceiver Macrocell Interface
UTMI+	USB 2.0 Transceiver Macrocell Interface Plus

19. References

- [1] Universal Serial Bus Specification Rev. 2.0
- [2] On-The-Go Supplement to the USB 2.0 Specification Rev. 1.3
- [3] UTMI+ Low Pin Interface (ULPI) Specification Rev. 1.1

- [4] UTMI+ Specification Rev. 1.0
- [5] USB 2.0 Transceiver Macrocell Interface (UTMI) Specification Ver. 1.05
- [6] Electrostatic Discharge (ESD) Sensitivity Testing Human Body Model (HBM) (JESD22-A114D)
- [7] Interfacing to the ISP1507 (AN10080)

20. Revision history

Table 59. Revision history

Revision	Release date	Data sheet status	Change notice
4	20100520	Product data sheet	-
Modifications:	<ul style="list-style-type: none"> • Table 45 "Static characteristics: supply pins": removed $I_{CC(I/O)(stat)}$. 		
3	20091022	Product data sheet	-
2	20090120	Product data sheet	-
1	20080528	Product data sheet	-

21. Tables

Table 1.	Ordering information	3		
Table 2.	Pin description	5		
Table 3.	Recommended charge pump capacitor value	12		
Table 4.	ULPI signal description	15		
Table 5.	Signal mapping during low-power mode	16		
Table 6.	Signal mapping for 3-pin serial mode	17		
Table 7.	Operating states and their corresponding resistor settings	18		
Table 8.	OTG_CTRL register power control bits	24		
Table 9.	TXCMD byte format	24		
Table 10.	RXCMD byte format	25		
Table 11.	LINESTATE[1:0] encoding for upstream facing ports: peripheral	26		
Table 12.	LINESTATE[1:0] encoding for downstream facing ports: host	26		
Table 13.	Encoded V _{BUS} voltage state	26		
Table 14.	V _{BUS} indicators in RXCMD required for typical applications	27		
Table 15.	Encoded USB event signals	28		
Table 16.	PHY pipeline delays	32		
Table 17.	Link decision times	33		
Table 18.	Immediate register set overview	45		
Table 19.	Extended register set overview	45		
Table 20.	VENDOR_ID_LOW - Vendor ID Low register (address R = 00h) bit description	46		
Table 21.	VENDOR_ID_HIGH - Vendor ID High register (address R = 01h) bit description	46		
Table 22.	PRODUCT_ID_LOW - Product ID Low register (address R = 02h) bit description	46		
Table 23.	PRODUCT_ID_HIGH - Product ID High register (address R = 03h) bit description	46		
Table 24.	FUNC_CTRL - Function Control register (address R = 04h to 06h, W = 04h, S = 05h, C = 06h) bit allocation	46		
Table 25.	FUNC_CTRL - Function Control register (address R = 04h to 06h, W = 04h, S = 05h, C = 06h) bit description	47		
Table 26.	INTF_CTRL - Interface Control register (address R = 07h to 09h, W = 07h, S = 08h, C = 09h) bit allocation	47		
Table 27.	INTF_CTRL - Interface Control register (address R = 07h to 09h, W = 07h, S = 08h, C = 09h) bit description	48		
Table 28.	OTG_CTRL - OTG Control register (address R = 0Ah to 0Ch, W = 0Ah, S = 0Bh, C = 0Ch) bit allocation	48		
Table 29.	OTG_CTRL - OTG Control register (address R = 0Ah to 0Ch, W = 0Ah, S = 0Bh, C = 0Ch) bit description	49		
Table 30.	USB_INTR_EN_R_E - USB Interrupt Enable Rising Edge register (address R = 0Dh to 0Fh, W = 0Dh, S = 0Eh, C = 0Fh) bit allocation	49		
Table 31.	USB_INTR_EN_R_E - USB Interrupt Enable Rising Edge register (address R = 0Dh to 0Fh, W = 0Dh, S = 0Eh, C = 0Fh) bit description	50		
Table 32.	USB_INTR_EN_F_E - USB Interrupt Enable Falling Edge register (address R = 10h to 12h, W = 10h, S = 11h, C = 12h) bit allocation	50		
Table 33.	USB_INTR_EN_F_E - USB Interrupt Enable Falling Edge register (address R = 10h to 12h, W = 10h, S = 11h, C = 12h) bit description	50		
Table 34.	USB_INTR_STAT - USB Interrupt Status register (address R = 13h) bit allocation	51		
Table 35.	USB_INTR_STAT - USB Interrupt Status register (address R = 13h) bit description	51		
Table 36.	USB_INTR_L - USB Interrupt Latch register (address R = 14h) bit allocation	51		
Table 37.	USB_INTR_L - USB Interrupt Latch register (address R = 14h) bit description	51		
Table 38.	DEBUG - Debug register (address R = 15h) bit allocation	52		
Table 39.	DEBUG - Debug register (address R = 15h) bit description	52		
Table 40.	SCRATCH - Scratch register (address R = 16h to 18h, W = 16h, S = 17h, C = 18h) bit description	52		
Table 41.	PWR_CTRL - Power Control register (address R = 3Dh to 3Fh, W = 3Dh, S = 3Eh, C = 3Fh) bit allocation	53		
Table 42.	PWR_CTRL - Power Control register (address R = 3Dh to 3Fh, W = 3Dh, S = 3Eh, C = 3Fh) bit description	53		
Table 43.	Limiting values	55		
Table 44.	Recommended operating conditions	55		
Table 45.	Static characteristics: supply pins	56		
Table 46.	Static characteristics: digital pins (CLOCK, DIR, STP, NXT, DATA[3:0], RESET_N/PSW_N)	56		
Table 47.	Static characteristics: digital pin FAULT	57		
Table 48.	Static characteristics: analog I/O pins (DP, DM)	57		
Table 49.	Static characteristics: charge pump	59		
Table 50.	Static characteristics: V _{BUS} comparators	59		
Table 51.	Static characteristics: V _{BUS} resistors	59		
Table 52.	Static characteristics: ID detection circuit	59		
Table 53.	Static characteristics: resistor reference	60		
Table 54.	Dynamic characteristics: reset and clock	61		
Table 55.	Dynamic characteristics: digital I/O pins	62		
Table 56.	Dynamic characteristics: analog I/O pins (DP and DM)	62		
Table 57.	Recommended list of materials	65		
Table 58.	Abbreviations	71		
Table 59.	Revision history	72		

22. Figures

Fig 1.	Block diagram	4
Fig 2.	Pin configuration HVQFN24; top view	5
Fig 3.	External capacitors connection	10
Fig 4.	Charge pump capacitor	11
Fig 5.	Internal power-on reset timing	20
Fig 6.	Power-up and reset sequence required before the ULPI bus is ready for use	22
Fig 7.	Interface behavior with respect to RESET_N	23
Fig 8.	Single and back-to-back RXCMDs from the ISP1507 to the link.	25
Fig 9.	RXCMD A_VBUS_VLD indicator source.	27
Fig 10.	Example of register write, register read, extended register write and extended register read	29
Fig 11.	USB reset and high-speed detection handshake (chirp) sequence	31
Fig 12.	Example of using the ISP1507 to transmit and receive USB data.	32
Fig 13.	High-speed transmit-to-transmit packet timing	34
Fig 14.	High-speed receive-to-transmit packet timing	34
Fig 15.	Preamble sequence.	35
Fig 16.	Full-speed suspend and resume	37
Fig 17.	High-speed suspend and resume	39
Fig 18.	Remote wake-up from low-power mode	41
Fig 19.	Transmitting USB packets without automatic SYNC and EOP generation	42
Fig 20.	Example of transmit followed by receive in 3-pin serial mode	44
Fig 21.	Human body ESD test model	54
Fig 22.	Charge pump supply current as a function of V_{BUS} output current.	60
Fig 23.	V_{BUS} output voltage as a function of V_{BUS} output current	60
Fig 24.	V_{BUS} output voltage as a function of charge pump supply voltage	60
Fig 25.	Charge pump supply current as a function of temperature	60
Fig 26.	Rise time and fall time	63
Fig 27.	Timing of DAT and SE0 when transmitting to DP and DM	63
Fig 28.	Timing of TX_ENABLE to DP and DM.	63
Fig 29.	Timing of DAT and SE0 when receiving from DP and DM	63
Fig 30.	ULPI timing	64
Fig 31.	Using the ISP1507 with an OTG controller; internal charge pump is utilized and crystal is attached	66
Fig 32.	Using the ISP1507 with an OTG controller; external charge pump using ISP1507 internal V_{BUS} valid and external square wave input on XTAL1	67
Fig 33.	Using the ISP1507 with a standard USB host controller; external 5 V source with built-in FAULT and external square wave input on XTAL1	68
Fig 34.	Using the ISP1507 with a standard USB peripheral controller; external crystal is used	69
Fig 35.	Package outline SOT616-3 (HVQFN24)	70

23. Contents

1	General description	1	8.1	ULPI modes	15
2	Features	1	8.1.1	Synchronous mode	15
3	Applications	2	8.1.2	Low-power mode	16
4	Ordering information	3	8.1.3	3-pin full-speed or low-speed serial mode	17
5	Block diagram	4	8.2	USB and OTG state transitions	17
6	Pinning information	5	9	Protocol description	20
6.1	Pinning	5	9.1	ULPI references	20
6.2	Pin description	5	9.2	Power-On Reset (POR)	20
7	Functional description	7	9.3	Power-up, reset and bus idle sequence	20
7.1	ULPI controller	7	9.3.1	Interface protection	22
7.2	USB data serializer and deserializer	7	9.3.2	Interface behavior with respect to RESET_N	23
7.3	Hi-Speed USB (USB 2.0) ATX	7	9.4	V _{BUS} power and fault detection	23
7.4	Voltage regulator	8	9.4.1	Driving 5 V on V _{BUS}	23
7.5	Crystal oscillator and PLL	8	9.4.2	Fault detection	24
7.6	OTG module	8	9.5	TXCMD and RXCMD	24
7.6.1	ID detector	9	9.5.1	TXCMD	24
7.6.2	V _{BUS} comparators	9	9.5.2	RXCMD	25
7.6.2.1	V _{BUS} valid comparator	9	9.5.2.1	Linestate encoding	25
7.6.2.2	Session valid comparator	9	9.5.2.2	V _{BUS} state encoding	26
7.6.2.3	Session end comparator	9	9.5.2.3	Using and selecting the V _{BUS} state encoding	27
7.6.3	SRP charge and discharge resistors	9	9.5.2.4	RxEvent encoding	28
7.6.4	Charge pump	9	9.6	Register read and write operations	29
7.7	Band gap reference voltage	10	9.7	USB reset and high-speed detection handshake (chirp)	29
7.8	Power-On Reset (POR)	10	9.8	USB packet transmit and receive	32
7.9	Detailed description of pins	10	9.8.1	USB packet timing	32
7.9.1	DATA[3:0]	10	9.8.1.1	ISP1507 pipeline delays	32
7.9.2	V _{CC(I/O)}	10	9.8.1.2	Allowed link decision time	33
7.9.3	RREF	11	9.9	Preamble	35
7.9.4	DP and DM	11	9.10	USB suspend and resume	35
7.9.5	ID	11	9.10.1	Full-speed or low-speed host-initiated suspend and resume	35
7.9.6	CPGND	11	9.10.2	High-speed suspend and resume	37
7.9.7	C_A and C_B	11	9.10.3	Remote wake-up	40
7.9.8	V _{CC}	12	9.11	No automatic SYNC and EOP generation (optional)	41
7.9.9	V _{BUS} /FAULT	12	9.12	On-The-Go operations	42
7.9.9.1	V _{BUS}	12	9.12.1	OTG charge pump	43
7.9.9.2	FAULT (external overcurrent or fault detector)	12	9.12.2	OTG comparators	43
7.9.10	REG3V3 and REG1V8	12	9.12.3	Pull-up and pull-down resistors	43
7.9.11	XTAL1 and XTAL2	12	9.12.4	ID detection	43
7.9.12	RESET_N/PSW_N	13	9.12.5	V _{BUS} charge and discharge resistors	43
7.9.12.1	RESET_N	13	9.13	Serial mode	43
7.9.12.2	PSW_N	13	9.14	Aborting transfers	44
7.9.13	DIR	13	9.15	Avoiding contention on the ULPI data bus	44
7.9.14	STP	13	10	Register map	45
7.9.15	NXT	14	10.1	Immediate register set	46
7.9.16	CLOCK	14			
7.9.17	GND (die pad)	14			
8	Modes of operation	15			

continued >>

10.1.1	Vendor ID and Product ID registers	46
10.1.1.1	VENDOR_ID_LOW register	46
10.1.1.2	VENDOR_ID_HIGH register	46
10.1.1.3	PRODUCT_ID_LOW register	46
10.1.1.4	PRODUCT_ID_HIGH register	46
10.1.2	FUNC_CTRL register	46
10.1.3	INTF_CTRL register	47
10.1.4	OTG_CTRL register	48
10.1.5	USB_INTR_EN_R_E register	49
10.1.6	USB_INTR_EN_F_E register	50
10.1.7	USB_INTR_STAT register	50
10.1.8	USB_INTR_L register	51
10.1.9	DEBUG register	52
10.1.10	SCRATCH register	52
10.1.11	Reserved	52
10.1.12	Access extended register set	52
10.1.13	Vendor-specific registers	52
10.1.14	PWR_CTRL register	52
10.2	Extended register set	53
11	ElectroStatic Discharge (ESD)	54
11.1	ESD protection	54
11.2	ESD test conditions	54
12	Limiting values.	55
13	Recommended operating conditions.	55
14	Static characteristics.	56
15	Dynamic characteristics	61
15.1	ULPI timing	63
16	Application information.	65
17	Package outline	70
18	Abbreviations.	71
19	References	71
20	Revision history.	72
21	Tables	73
22	Figures	74
23	Contents	75

Please Read Carefully:

The contents of this document are subject to change without prior notice. ST-Ericsson makes no representation or warranty of any nature whatsoever (neither expressed nor implied) with respect to the matters addressed in this document, including but not limited to warranties of merchantability or fitness for a particular purpose, interpretability or interoperability or, against infringement of third party intellectual property rights, and in no event shall ST-Ericsson be liable to any party for any direct, indirect, incidental and or consequential damages and or loss whatsoever (including but not limited to monetary losses or loss of data), that might arise from the use of this document or the information in it.

ST-Ericsson and the ST-Ericsson logo are trademarks of the ST-Ericsson group of companies or used under a license from STMicroelectronics NV or Telefonaktiebolaget LM Ericsson.

All other names are the property of their respective owners.

© ST-Ericsson, 2010 - All rights reserved

Contact information at www.stericsson.com under Contacts

www.stericsson.com