



## up to Category 2, EN 954-1 PNOZ X1



Safety relay for monitoring E-STOP pushbuttons.

### Approvals

	PNOZ X1
	◆
	◆
	◆

### Unit features

- ▶ Positive-guided relay outputs:
  - 3 safety contacts (N/O), instantaneous
  - 1 auxiliary contact (N/C), instantaneous
- ▶ Safe separation of safety contacts 13-14, 23-24, 33-34 from input circuits A1-A2, feedback loop Y1-Y2 and auxiliary contact 41-42.
- ▶ Connection options for:
  - E-STOP pushbutton
  - Reset button
- ▶ LED indicator for:
  - Switch status channel 1/2
  - Supply voltage

### Safety features

- The relay meets the following safety requirements:
- ▶ The circuit is redundant with built-in self-monitoring.
  - ▶ The safety function remains effective in the case of a component failure.
  - ▶ The correct opening and closing of the safety function relays is tested automatically in each on-off cycle.

### Unit description

The safety relay meets the requirements of EN 60204-1 and IEC 60204-1 and may be used in applications with

- ▶ E-STOP pushbuttons

The safety relay is not suitable for non-contact barriers because

- ▶ a dynamic start is not possible
- ▶ the unit can be started during the delay-on de-energisation time.

### Block diagram

\* Safe separation in accordance with EN 60947-1, 6 kV (see unit features)

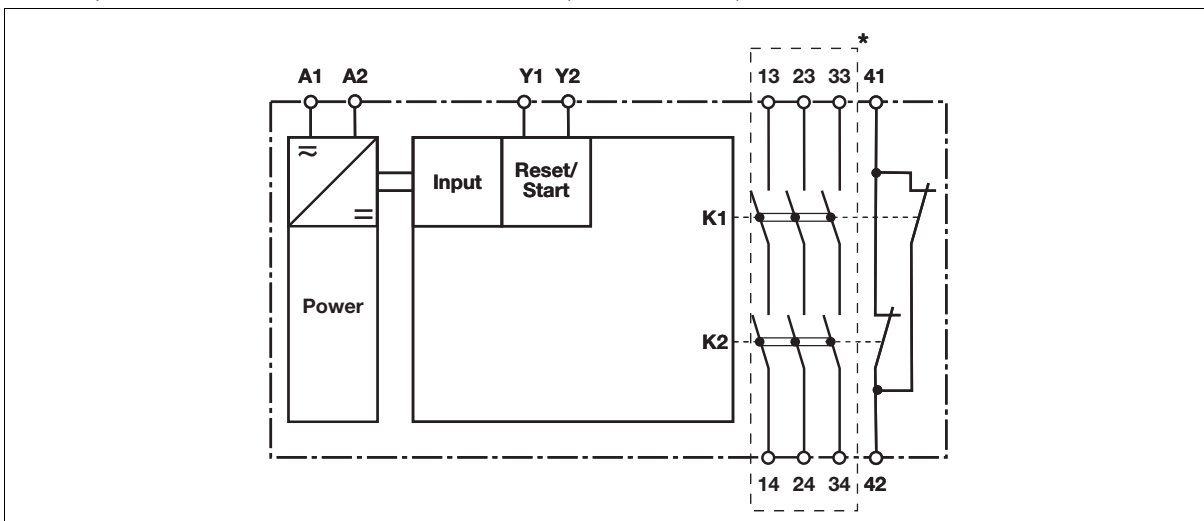

## up to Category 2, EN 954-1 PNOZ X1

### Function description

- ▶ Single-channel operation: no redundancy in the input circuit, earth faults in the reset circuit are detected.
- ▶ Automatic start: Unit is active once the input circuit has been closed.
- ▶ Manual reset: Unit is active once the input circuit is closed and then the reset circuit is closed.
- ▶ Increase in the number of available contacts by connecting contact expander modules or external contactors/relays.

### Timing diagram

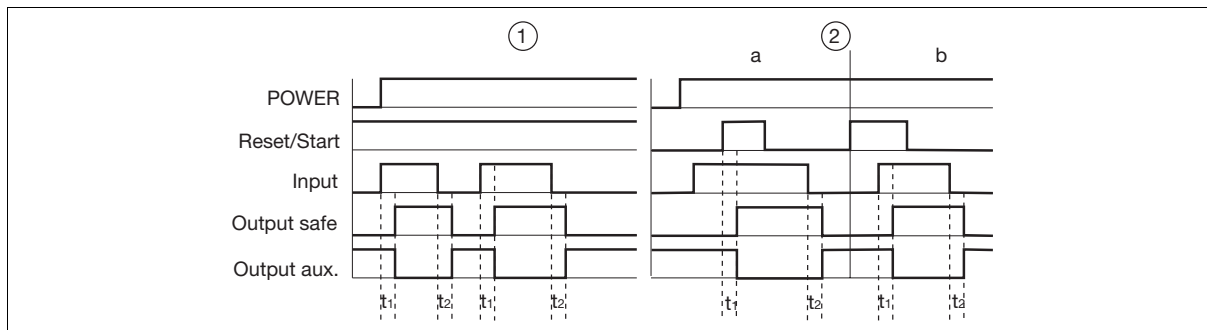

### Key

- ▶ Power: Supply voltage
- ▶ Reset/start: Reset circuit Y1-Y2
- ▶ Input: Input circuits A1-L+
- ▶ Output safe: Safety contacts 13-14, 23-24, 33-34
- ▶ Output aux: Auxiliary contacts 41-42
- ▶ ①: Automatic reset
- ▶ ②: Manual reset
- ▶ a: Input circuit closes before reset circuit
- ▶ b: Reset circuit closes before input circuit
- ▶ t<sub>1</sub>: Switch-on delay
- ▶ t<sub>2</sub>: Delay-on de-energisation

### Wiring

Please note:

- ▶ Information given in the “Technical details” must be followed.
- ▶ Outputs 13-14, 23-24, 33-34 are safety contacts, output 41-42 is an auxiliary contact (e.g. for display).
- ▶ To prevent contact welding, a fuse should be connected before the output contacts (see technical details).
- ▶ Calculation of the max. cable runs I<sub>max</sub> in the input circuit:

$$I_{\max} = \frac{R_{l_{\max}}}{R_l / \text{km}}$$

R<sub>l<sub>max</sub></sub> = max. overall cable resistance (see technical details)

R<sub>l</sub> /km = cable resistance/km

- ▶ Use copper wire that can withstand 60/75 °C.
- ▶ Sufficient fuse protection must be provided on all output contacts with capacitive and inductive loads.



## up to Category 2, EN 954-1 PNOZ X1

### Preparing for operation

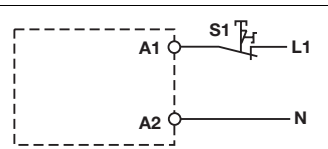
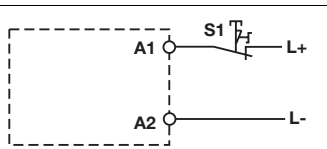
#### ► Supply voltage

Supply voltage	AC	DC
		

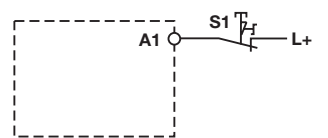
#### ► Input circuit

Input circuit	Single-channel	Dual-channel
E-STOP <b>without</b> detection of shorts across contacts		

#### ► Reset circuit

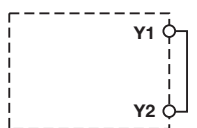
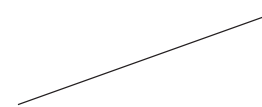
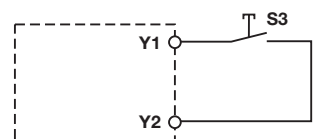
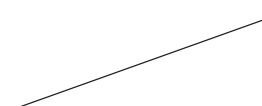
Reset circuit	E-STOP wiring (single-channel)	E-STOP wiring (dual-channel)
Automatic reset		
Manual reset		

#### ► Feedback loop

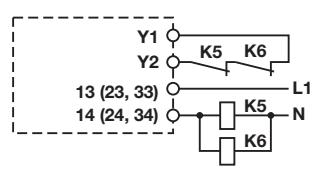
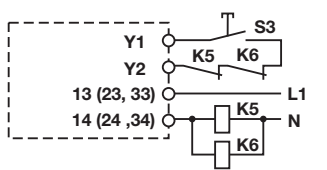
Feedback loop	Automatic reset	Manual reset
Contacts from external contactors		

#### ► Key

S1	E-STOP pushbutton
S3	Reset button

## up to Category 2, EN 954-1 PNOZ X1

### Terminal configuration

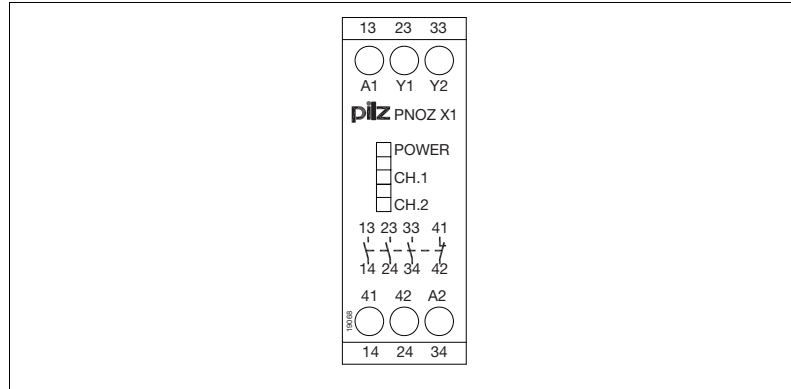

### Installation

- ▶ The safety relay should be installed in a control cabinet with a protection type of at least IP54.
- ▶ Use the notch on the rear of the unit to attach it to a DIN rail.
- ▶ Ensure the unit is mounted securely on a vertical DIN rail (35 mm) by using a fixing element (e.g. retaining bracket or an end angle).

### Dimensions

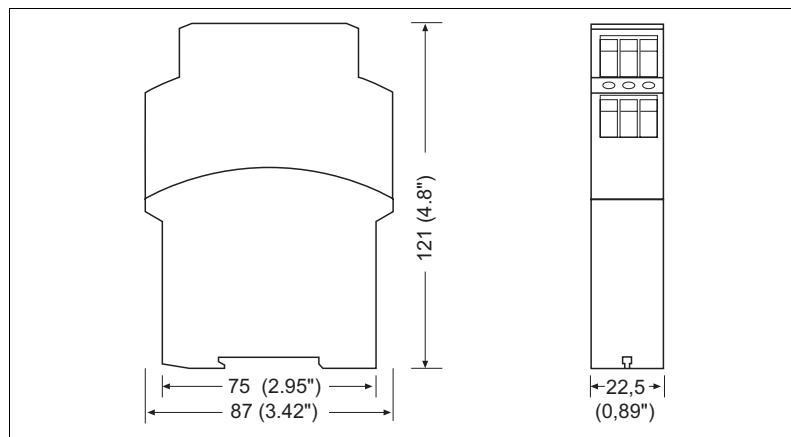

## up to Category 2, EN 954-1 PNOZ X1

### Notice

This data sheet is only intended for use during configuration. For installation and operation, please refer to the operating instructions supplied with the unit.

### Service life graph

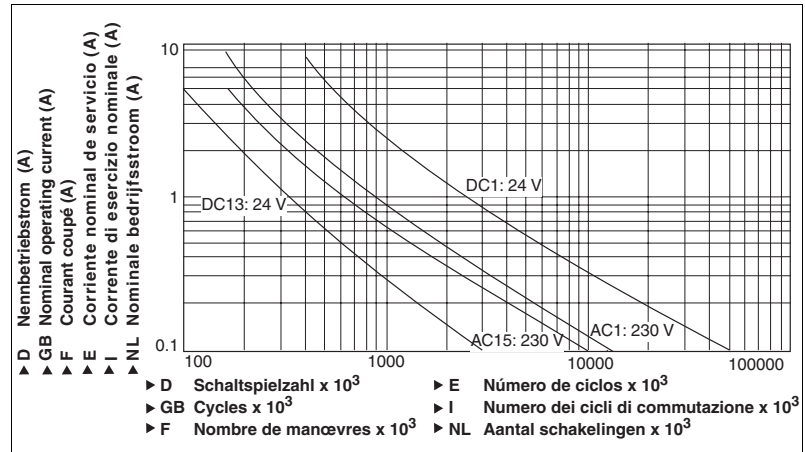

### Technical details

#### Electrical data

Supply voltage	
Supply voltage $U_B$ AC/DC	<b>24 V</b>
Voltage tolerance	<b>-15 %/+10 %</b>
Power consumption at $U_B$ AC	<b>4.0 VA</b>
Power consumption at $U_B$ DC	<b>2.0 W</b>
Frequency range AC	<b>50 - 60 Hz</b>
Residual ripple DC	<b>160 %</b>
Voltage and current at	
Input circuit DC: <b>24.0 V</b>	<b>65.0 mA</b>
Reset circuit DC: <b>24.0 V</b>	<b>40.0 mA</b>
Feedback loop DC: <b>24.0 V</b>	<b>40.0 mA</b>
Number of output contacts	
Safety contacts (S) instantaneous:	<b>3</b>
Auxiliary contacts (N/C):	<b>1</b>
Category of output contacts in accordance with <b>EN 954-1</b>	
Safety contacts (S) instantaneous:	<b>2</b>
Utilisation category in accordance with <b>EN 60947-4-1</b>	
Safety contacts: AC1 at <b>240 V</b>	$I_{min}: 0.01 A, I_{max}: 8.0 A$ $P_{max}: 2000 VA$
Safety contacts: DC1 at <b>24 V</b>	$I_{min}: 0.01 A, I_{max}: 8.0 A$ $P_{max}: 200 W$
Auxiliary contacts: AC1 at <b>240 V</b>	$I_{min}: 0.01 A, I_{max}: 8.0 A$ $P_{max}: 2000 VA$
Auxiliary contacts: DC1 at <b>24 V</b>	$I_{min}: 0.01 A, I_{max}: 8.0 A$ $P_{max}: 200 W$
Utilisation category in accordance with <b>EN 60947-5-1</b>	
Safety contacts: AC15 at <b>230 V</b>	$I_{max}: 6.0 A$
Safety contacts: DC13 at <b>24 V</b> (6 cycles/min)	$I_{max}: 5.0 A$
Auxiliary contacts: AC15 at <b>230 V</b>	$I_{max}: 6.0 A$
Auxiliary contacts: DC13 at <b>24 V</b> (6 cycles/min)	$I_{max}: 5.0 A$
Contact material	<b>AgCuNi + 0.2 µm Au</b>

## up to Category 2, EN 954-1 PNOZ X1

<b>Electrical data</b>	
External contact fuse protection ( $I_k = 1 \text{ kA}$ ) to <b>EN 60947-5-1</b>	
Blow-out fuse, quick	
Safety contacts:	<b>10 A</b>
Auxiliary contacts:	<b>10 A</b>
Blow-out fuse, slow	
Safety contacts:	<b>6 A</b>
Auxiliary contacts:	<b>6 A</b>
Circuit breaker 24 VAC/DC, characteristic B/C	
Safety contacts:	<b>6 A</b>
Auxiliary contacts:	<b>6 A</b>
Max. overall cable resistance $R_{lmax}$ input circuits, reset circuits	
single-channel at $U_B$ DC	<b>30 Ohm</b>
single-channel at $U_B$ AC	<b>30 Ohm</b>
<b>Times</b>	
Switch-on delay	
with automatic reset typ.	<b>60 ms</b>
with automatic reset max.	<b>120 ms</b>
with manual reset typ.	<b>50 ms</b>
with manual reset max.	<b>120 ms</b>
Delay-on de-energisation	
with E-STOP typ.	<b>55 ms</b>
with E-STOP max.	<b>90 ms</b>
with power failure typ.	<b>55 ms</b>
with power failure max.	<b>90 ms</b>
Recovery time at max. switching frequency 1/s after E-STOP	
after power failure	<b>100 ms</b>
Supply interruption before de-energisation	<b>20 ms</b>
<b>Environmental data</b>	
EMC	<b>EN 60947-5-1, EN 61000-6-2</b>
Vibration to <b>EN 60068-2-6</b>	
Frequency	<b>10 - 55 Hz</b>
Amplitude	<b>0.35 mm</b>
Climatic suitability	<b>EN 60068-2-78</b>
Airgap creepage	<b>EN 60947-1</b>
Rated insulation voltage	<b>250 V</b>
Rated impulse withstand voltage	<b>6.0 kV</b>
Ambient temperature	<b>-10 - 55 °C</b>
Storage temperature	<b>-40 - 85 °C</b>
Protection type	
Mounting (e.g. cabinet)	<b>IP54</b>
Housing	<b>IP40</b>
Terminals	<b>IP20</b>
<b>Mechanical data</b>	
Housing material	
Housing	<b>PPO UL 94 V0</b>
Front	<b>ABS UL 94 V0</b>
Max. cross section of external conductors with screw terminals	
1 core flexible	<b>0.20 - 4.00 mm<sup>2</sup>, 24 - 10 AWG</b>
2 core, same cross section, flexible:	
with crimp connectors, without insulating sleeve	<b>0.20 - 2.50 mm<sup>2</sup>, 24 - 14 AWG</b>
without crimp connectors or with TWIN crimp connectors	<b>0.20 - 2.50 mm<sup>2</sup>, 24 - 14 AWG</b>
Torque setting with screw terminals	<b>0.60 Nm</b>

## up to Category 2, EN 954-1 PNOZ X1

Mechanical data	
Dimensions	
Height	87.0 mm
Width	22.5 mm
Depth	121.0 mm
Weight	180 g

The standards current on **2004-09** apply.

Conventional thermal current		
Number of contacts	$I_{th}$ (A) at $U_B$ DC	$I_{th}$ (A) at $U_B$ AC
1	8.00 A	8.00 A
2	7.00 A	7.00 A
3	6.00 A	6.00 A

Order reference				
Type	Features		Terminals	Order no.
PNOZ X1	24 VAC	24 VDC	Screw terminals	774 300