

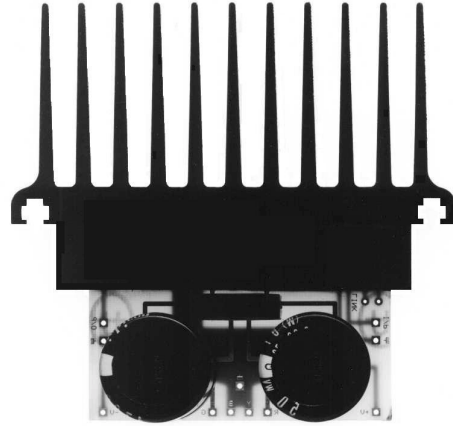

DATA SHEET

HY2003 60 WATTS



The ILP HY2003 Power Amplifier is a fully encapsulated high quality power amplifier with Integral Power Supply and heatsink.

By selecting the appropriate mains transformer and the programming link on the PCB the amplifier can be used with 4 or 8Ω loads with the automatic adjustment of input sensitivity.

Mounting can be achieved by the use of T-slots in the heatsink and the nuts and bolts provided.

TYPICAL SPECIFICATIONS	
Parameter	Value
Output Power	75W rms. Max
Frequency Response (-3dB)	15Hz - 50kHz
Total Harmonic Distortion @ 1kHz	0.005%
Signal to Noise Ratio (DIN AUDIO)	100dB
Slew Rate typical	15V/μS
Rise Time	5μS
Input Sensitivity	500mV rms.
Input Impedance	100KΩ
Damping Factor(8Ω @ 100Hz)	>400
Load Impedance (programmable)	4 or 8Ω
Maximum D.C. rails (8Ω load)	±40V
Size Width x Height x Extrusion Cut	120x115x30mm
Weight	360g

- FEATURES
- Programmable 4 or 8Ω operation
- Integral Power Supply
- Anti-thump Circuitry
- Integral heatsink
- Thermal Protection
- PTH Circuit Board
- Encapsulated

POWER SUPPLY REQUIREMENTS

ILP have developed a range of Hi-Fi quality Low noise Audio Power Toroidal Transformers for the HY2003 they are Low Profile with Resin filled centres for maximum noise absorption and ease of mounting. Finished in black to match the amplifiers these transformers are the ideal choice to power the HY2003.

Mode	Transformer	RMS Supply Voltage	Size	Weight
4Ω	AT0604	20 - 0 - 20v	108x40mm	1.75Kg
8Ω	AT0608	28 - 0 - 28v	108x40mm	1.75Kg

SPONG LANE ELMSTED ASHFORD KENT TN25 5JU
 PHONE +44 (0)1233 750481 FAX +44 (0)1233 750578

ELECTRICAL / MECHANICAL DETAILS AND DIMENSIONS

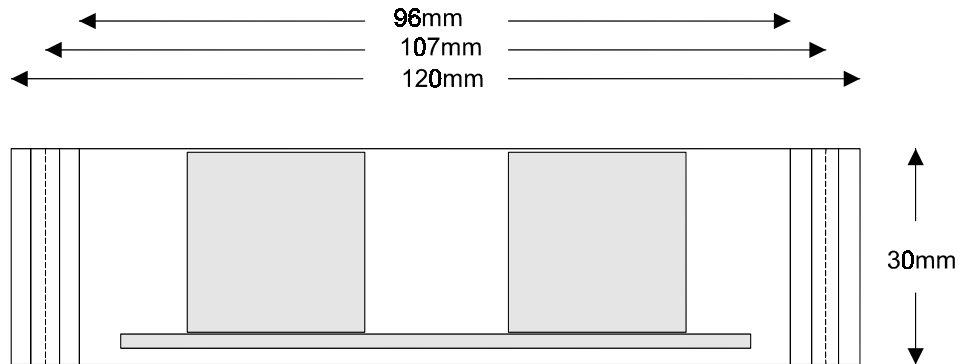

P.C.B. TERMINATIONS

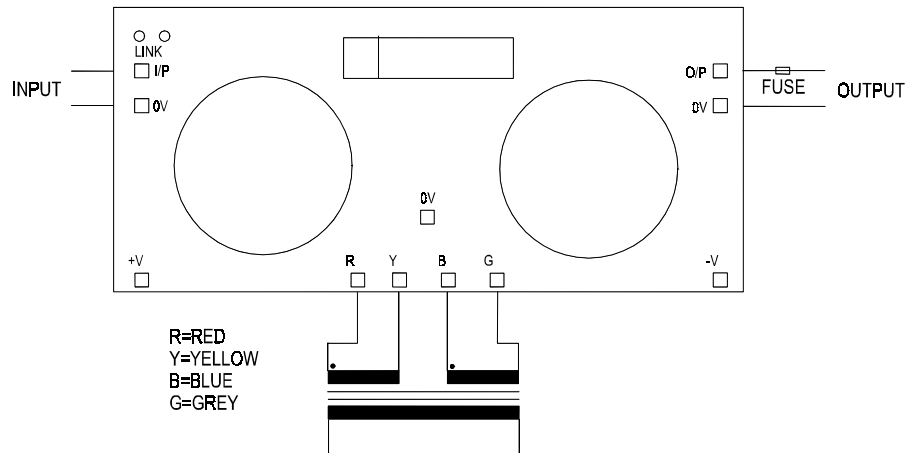

INSTALLATION NOTES

1. For normal usage and conditions the amplifier needs no supplementary heatsink.
2. It must be mounted to allow a vertical flow of air through the fins.
3. No input capacitor is required. An internal 100V working capacitor is fitted.
4. For loudspeaker protection it is recommended that a quickblow fuse is mounted between the output and the speaker. The fuse rating specified has been calculated to ensure fast rupture in the event of DC being presented to the speaker. It is advised not to use a higher rated fuse.
5. The amplifier module is supplied in 4Ω mode. To set 8Ω mode simply make a link between the two pads marked 'link'.
6. For 4Ω mode use a 2.5A quickblow fuse and for 8Ω a 2.0A quickblow fuse.