

SMD MICROPROCESSOR CRYSTAL



ABMC2



11.0 x 5.0 x 2.0 mm

FEATURES:

- 2.0 mm height
- Hermetically sealed package offers high reliability.
- AT cut offers tighter stability
- Resistance welded
- Extended temperature available
- Low frequency in SMD package
- IR Reflow capable

APPLICATIONS:

- PCMCIA applications
- Microprocessors
- Communication equipment, Networking, Thin equipment

STANDARD SPECIFICATIONS:

ABRACON P/N:	ABMC2 Series
Frequency:	3.579545 MHz to 70 MHz
Operation mode:	AT-strip or BT-strip 3.5 MHz - 32.00 MHz (Fundamental AT-cut: Standard) 32.00 MHz - 70.00 MHz (3rd OT AT-cut: Standard) 32.00 MHz - 41.00 MHz (Fundamental AT-cut: See options) 22.00 MHz - 46.00 MHz (Fundamental BT-cut: See options)
Operating temperature:	- 10°C to + 60°C (see options)
Storage temperature:	- 40°C to + 85° C
Frequency tolerance:	± 50 ppm max. (see options)
Frequency stability over the operating temperature (Ref to +25° C):	± 100 ppm max. (see options) ± 100 ppm max. over - 40°C to + 85° C only for BT-cut
Equivalent series resistance (max.):	See Table 1
Shunt capacitance C0:	7.0pF max.
Load capacitance CL:	18.0pF (see option)
Drive level:	100 µW max.
Aging (per year) @ 25° C:	± 5 ppm max.
Insulation resistance:	500 MΩ min. at 100 Vdc ± 15 Vdc

Table 1 Standard ESR

Frequency (MHz)	ESR(Ω) max.
3.500 - 3.999 (AT cut fund.)	180
4.000 - 4.999 (AT cut fund.)	150
5.000 - 5.999 (AT cut fund.)	120
6.000 - 6.999 (AT cut fund.)	100
7.000 - 8.999 (AT cut fund.)	80
9.000 - 12.999 (AT cut fund.)	60
13.00 - 19.999 (AT cut fund.)	50
20.00 - 41.00 (AT cut fund.)	40
22.00 - 46.00 (BT cut)	60
32.00 - 70.00 (3rd O/T)	80

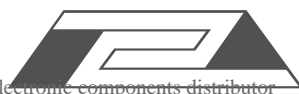

SMD MICROPROCESSOR CRYSTAL



ABMC2



11.0 x 5.0 x 2.0 mm

OPTIONS AND PART IDENTIFICATION:

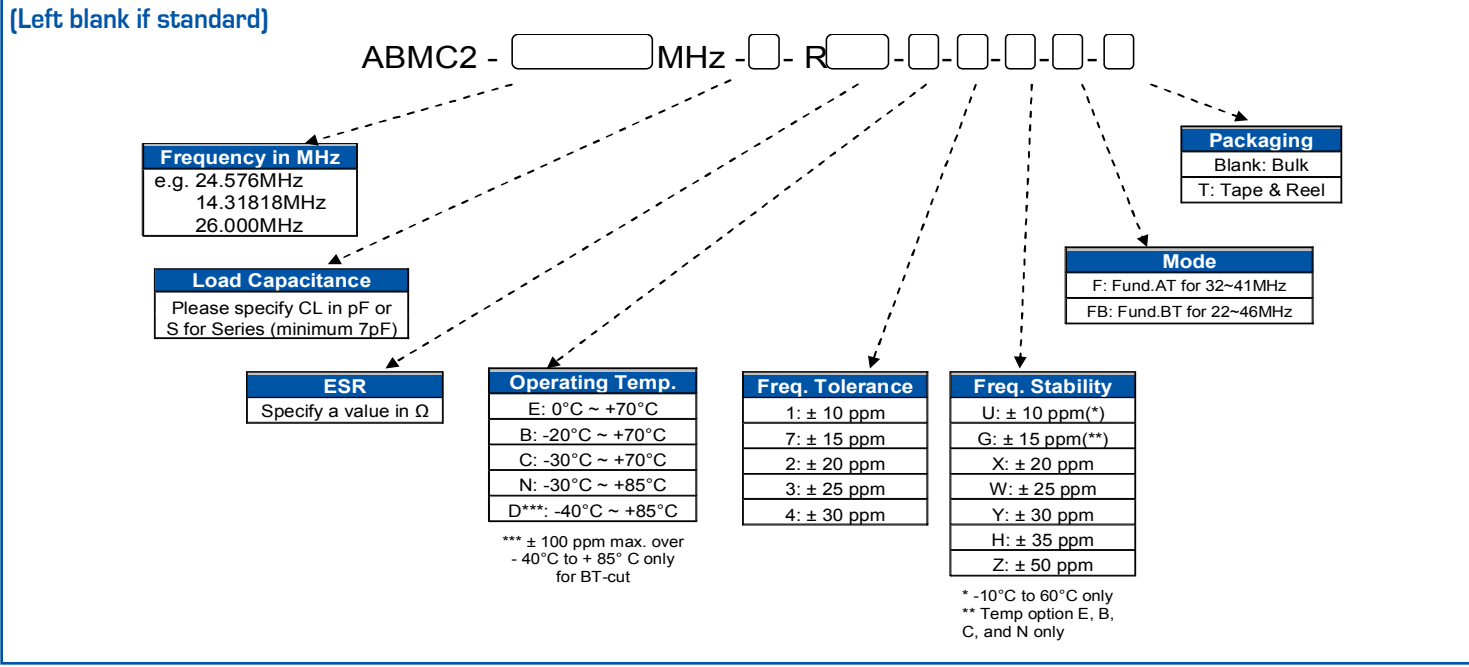

OUTLINE DRAWING:

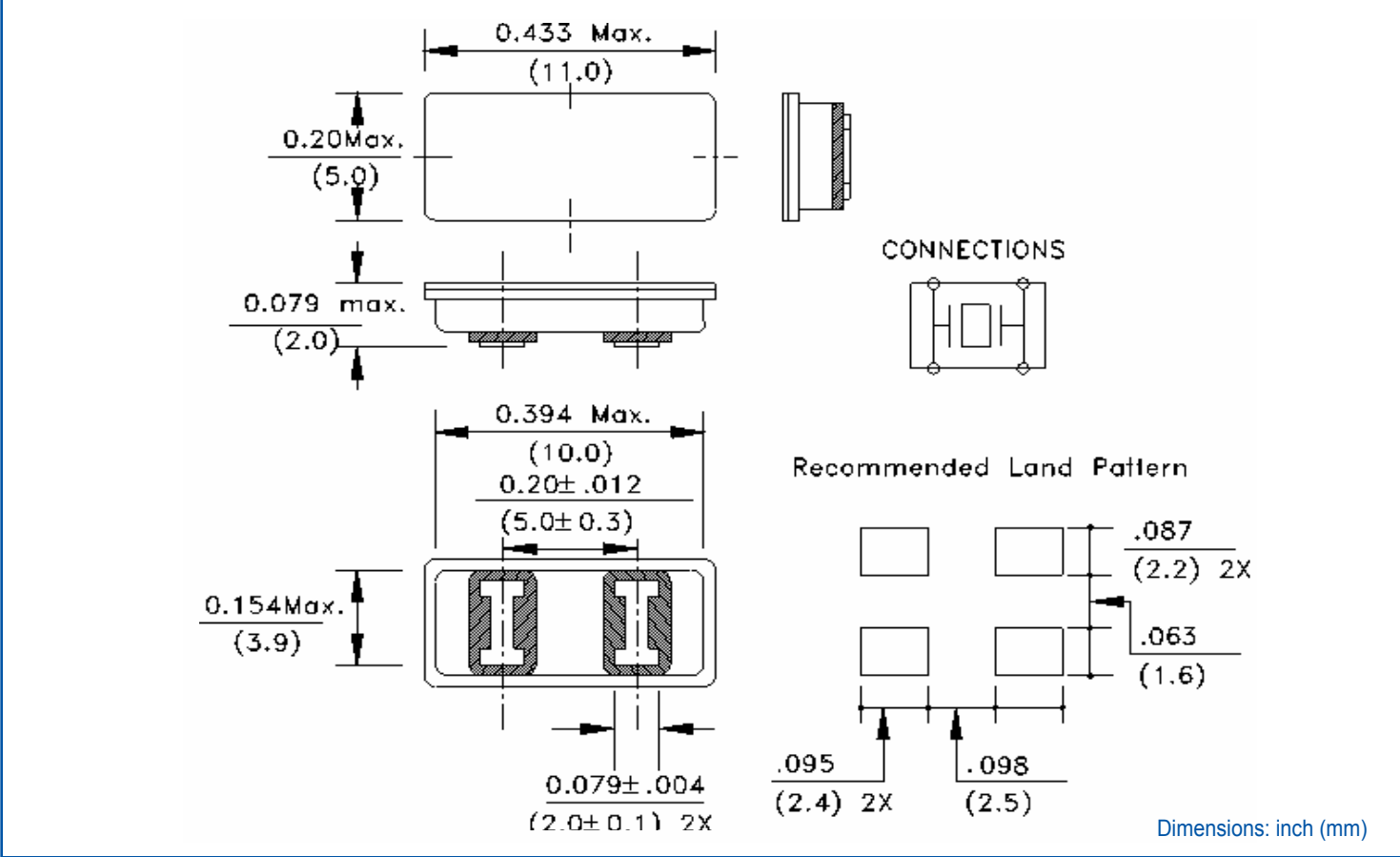

ABRACON IS ISO9001:2008 CERTIFIED



ABRACON CORPORATION

Visit www.abracon.com for Terms & Conditions of Sale **Revised: 08.19.10**
30332 Esperanza, Rancho Santa Margarita, California 92688
tel 949-546-8000 | fax 949-546-8001 | www.abracon.com

SMD MICROPROCESSOR CRYSTAL



ABMC2

Pb RoHS Compliant

11.0 x 5.0 x 2.0 mm

▷ **TAPE & REEL:** T = Tape and reel 1,000pcs/reel

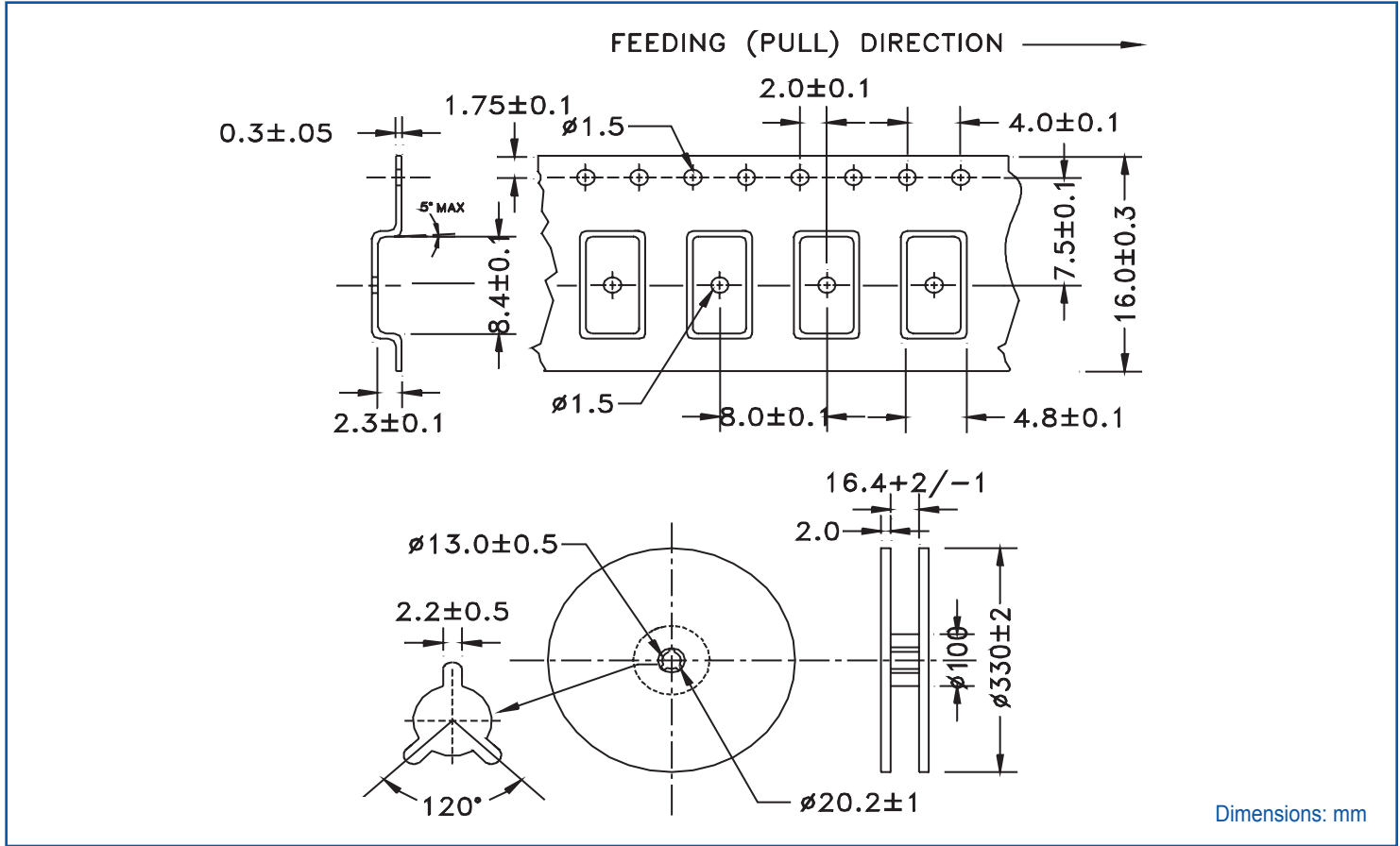

▷ **REFLOW PROFILE:**

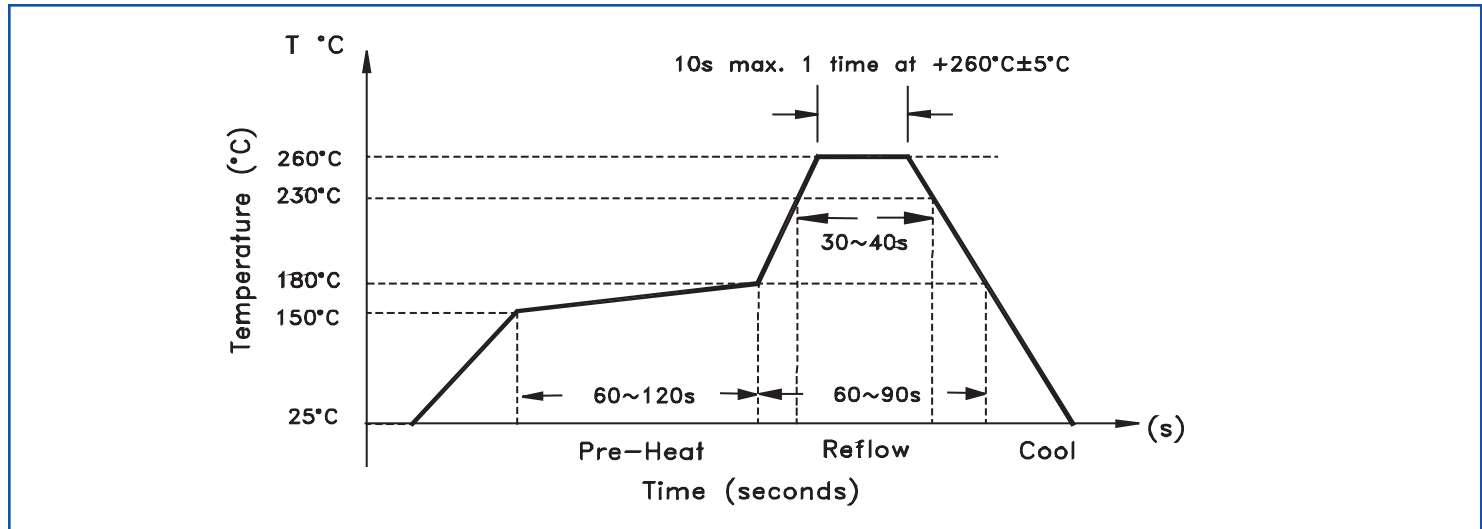

ATTENTION: Abracon Corporation's products are COTS – Commercial-Off-The-Shelf products; suitable for Commercial, Industrial and, where designated, Automotive Applications. Abracon's products are not specifically designed for Military, Aviation, Aerospace, Life-dependant Medical applications or any application requiring high reliability where component failure could result in loss of life and/or property. For applications requiring high reliability and/or presenting an extreme operating environment, written consent and authorization from Abracon Corporation is required. Please contact Abracon Corporation for more information.

ABRACON IS ISO9001:2008 CERTIFIED

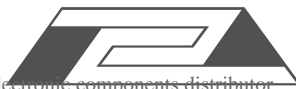

ABRACON CORPORATION

Visit www.abracon.com for Terms & Conditions of Sale **Revised: 08-19-10**
30332 Esperanza, Rancho Santa Margarita, California 92688
tel 949-546-8000 | fax 949-546-8001 | www.abracon.com