

XE0092 Surface-Mount DAA Module

DESCRIPTION

The XE0092 supplies a complete telephone line interface or DAA (Data Access Arrangement) in a compact, surface-mount module. It offers an alternative to a discrete DAA for a multitude of voice, audio, DTMF, fax and data applications. The XE0092 replaces 25 to 30 discrete components with a single, fully-assembled and fully-tested unit.

The XE0092 does not sacrifice performance for small size and surface-mount convenience. The wide bandwidth, low distortion design provides sufficient bandwidth for a 56K bps analog modem.

Like all our DAA's the XE0092 is a complete DAA. It includes a 2-4 wire converter, loop current holding circuit, hook switch and ring indicator. It also supports Caller ID. The XE0092 complies with FCC Part 68 rules for direct connection to the telephone line.

Cermetek offers the XE0092 in three lead styles; the XE0092 with gull-wing leads the, leadless XE0092LCC, and the XE0092T through-hole model. All versions offer the same outstanding performance.

MODELS

- XE0092 - Leaded Surface Mount Module
- XE0092LCC - Leadless Surface Mount Module
- XE0092T - Leaded Through-Hole Module
- XE0092-ET - Leaded Surface Mount -40° to +85°C
- XE0092LCC-ET - Leadless Surface Mount -40° to +85°C
- XE0092T-ET - Leaded Through-Hole -40° to +85°C

FEATURES

- * Low-profile, surface-mount package; XE0092, XE0092LCC;
- * Meets line interface requirements for reliable V.90 and V.92 communications;
- * Typical Second Harmonic Distortion of -80 dB;
- * Part 68 Compliant;
- * Integrated 2-to-4 wire converter provides 40 dB Transhybrid Loss
- * Supports detection of incoming Caller ID signals;
- * Integrated Ring Detection,
- * Low power operation: Just 10 milliamps from a single + 3.3 Volt Power Supply;
- * Solid-State Hook Switch Control;

Figure 1: Functional Block Diagram of XE0092

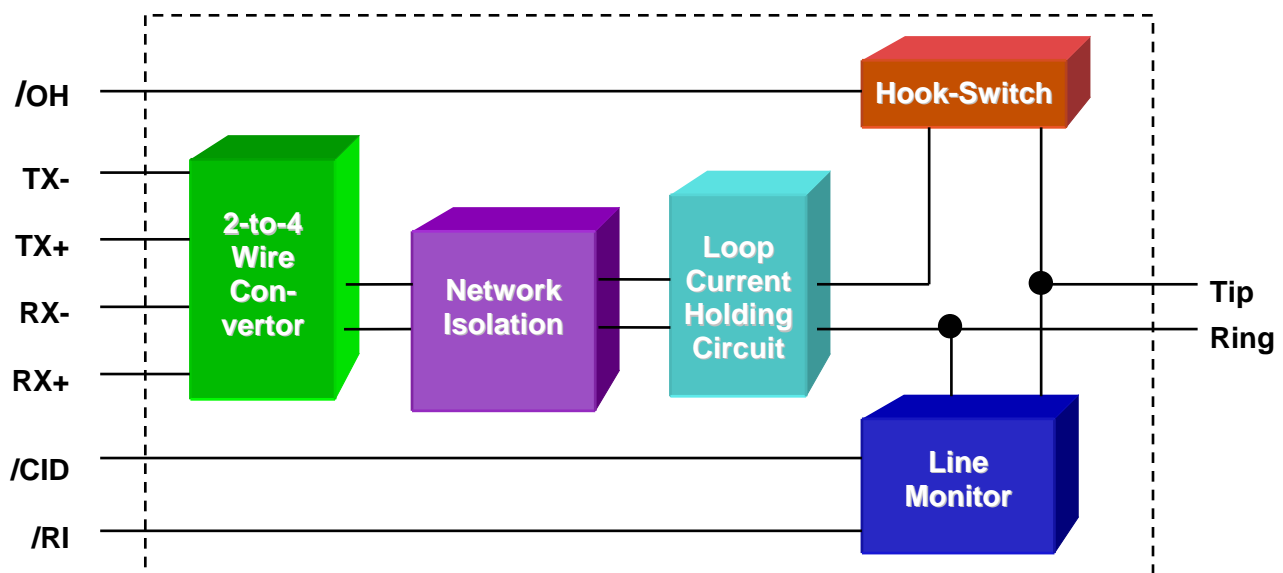

XE0092 PIN DESCRIPTIONS

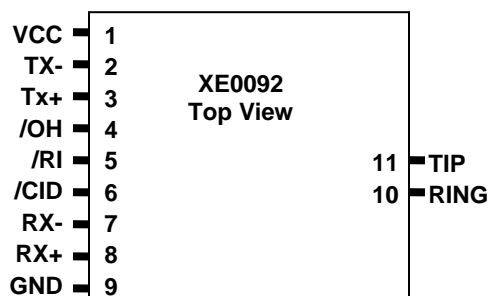

Pin Name Description

- 1 VCC +3.3 or 5 Volt power source for the XE0092. VCC powers the /RI and /OH control lines.
- 2 TX- TX- is the negative half of the differential transmit data input to the XE0092 from the host system. If the host system uses a single ended transmit data output, that output should be connected to TX- and TX+ should be grounded.
- 3 TX+ TX+ is the positive half of the differential transmit data input to the XE0092 from the host system. If the host system uses a single ended transmit data output, that output should be connected to TX- and TX+ should be grounded.
- 4 /OH Switch-hook control to the modem. /OH is an active low input. Activating OH closes the switch-hook causing the XE0092 to seize the local telephone line. The telephone line connection is dropped when OH is deactivated.

The host can pulse OH to simulate rotary dialing. The pulse rate in the US is ten pulses per second. Each digit is dialed as a series of pulses created by closure of the hook-switch, one pulse for the digit one to ten pulses for the digit zero. The pulses must be asymmetrical so that the hook-switch is closed for thirty-one milliseconds and open for sixty-nine milliseconds. An inter-digit delay of at least one hundred milliseconds is required.

Pin Name Description

- 5 /RI Ring Indicate output from the module. /RI is active low. RI goes low for the duration of each incoming ring, returning high between rings. The XE0092 recognizes ring voltages of twenty-eight to one hundred fifty volts RMS in the frequency range of sixteen to sixty-eight Hertz.
- 6 /CID /CID is an active low input to the XE0092. The host drives /CID low after the first ring to permit the Caller ID signal to be presented on the RX outputs. The telephone network normally sends Caller ID information on incoming calls between the first and second ring.
- 7 RX- RX- is the negative half of the differential received data output from the XE0092. If the host system uses a single ended received data input, that input should be connected to RX+ and RX- should remain open.
- 8 RX+ RX+ is the positive half of the differential received data output from the to the host system. If the host system uses a single ended received data input, that input should be connected to RX+ and RX- should remain open.
- 9 GND Ground connection to the XE0092. This signal provides the reference for the /OH input and /RI output. This pin should be connected to the systems digital ground.
- 10 Ring Ring is one wire of the two-wire telephone line connection (RJ11 Pin 3). FCC Part 68 Rules require a 1500 volt isolation barrier between the telephone line and all other circuits. This isolation must be preserved throughout the system. Cermetek recommends 0.100 inch spacing between traces connected to Ring and all other conductors to preserve this isolation
- 11 Tip Tip is one wire of the two-wire telephone line connection (RJ11 Pin 4). The telephone company places a DC "Battery" voltage across Tip and Ring on all public switched telephone lines. The XE0092 accept this line battery voltage without regard to its polarity.

XE0092 APPLICATION NOTES

Dialing:

The public switched telephone network permits tone and rotary (pulse) dialing. The XE0092 supports both types. Tone dialing requires an external signal source to generate the dialing tones. The /OH line on the XE0092 may be pulsed to create pulse dialing.

Pulse Dialing: The XE0092 generates dialing pulses through momentary closures of the switch-hook. Each digit is represented as a series of pulses, one pulse for a one to ten pulses for a zero. The pulse rate in North America is ten pulses per second. The dialing pulses are asymmetrical. The correct duty cycle in North America is 31 milliseconds on and 69 milliseconds off. An inter-digit delay of at least one hundred milliseconds separates the digits.

Tone Dialing: To permit tone dialing the XE0092 seizes the line, /OH active. For each digit a unique DTMF, Dual Tone Multiple Frequency, tone pair is applied to TX+ and TX-. The higher frequency tone is always larger than the lower frequency one. Transmit the tones for a minimum of 70 milliseconds, and leave a minimum of 70 milliseconds between digits.

The following chart shows the correct DTMF signal frequencies for each digit.

| <u>Digit</u> | <u>Lower Tone</u> | <u>Upper Tone</u> |
|--------------|-------------------|-------------------|
| 1 | 697 | 1209 |
| 2 | 697 | 1336 |
| 3 | 697 | 1477 |
| 4 | 770 | 1209 |
| 5 | 770 | 1336 |
| 6 | 770 | 1477 |
| 7 | 852 | 1209 |
| 8 | 852 | 1336 |
| 9 | 852 | 1477 |
| 0 | 941 | 1336 |
| * | 941 | 1209 |
| # | 941 | 1477 |

Signal Levels:

FCC Part 68 Rules set the allowable signal level in the US for all signals placed on the telephone line other than live voice. Other countries have similar regulations. Signal levels are measured in dBm. Zero dBm is 1 milliwatt through a 600 ohm load.

Distortion:

Distortion is the most common measure of the quality of the signal path provided by the DAA. The primary source of this distortion is the line current holding circuit, although board layout and other factors can introduce distortion.

Distortion varies with frequency. The voice band of the telephone line is limited to less than 4000 Hz. High speed modems such as 33.6K bps and 56K bps require virtually all of this bandwidth for signal transmission. Even if the distortion through a device is good in the center portion of the spectrum, signal quality is compromised if distortion greatly increases at the outer limits of the voice band. The XE0092 provides a low distortion signal path across the entire voice band.

Caller ID Reporting:

The telephone network normally sends the Caller ID signal between the first and second ring signals. If the user activates the /CID input while the XE0092 is off-hook, the Caller ID signal is passed through to the host through the RX pins on the XE0092. If the XE0092 is off-hook, /OH low, Caller ID pass-through cannot be enabled regardless of the state of /CID.

Typical Connections Diagram for North America and Japan

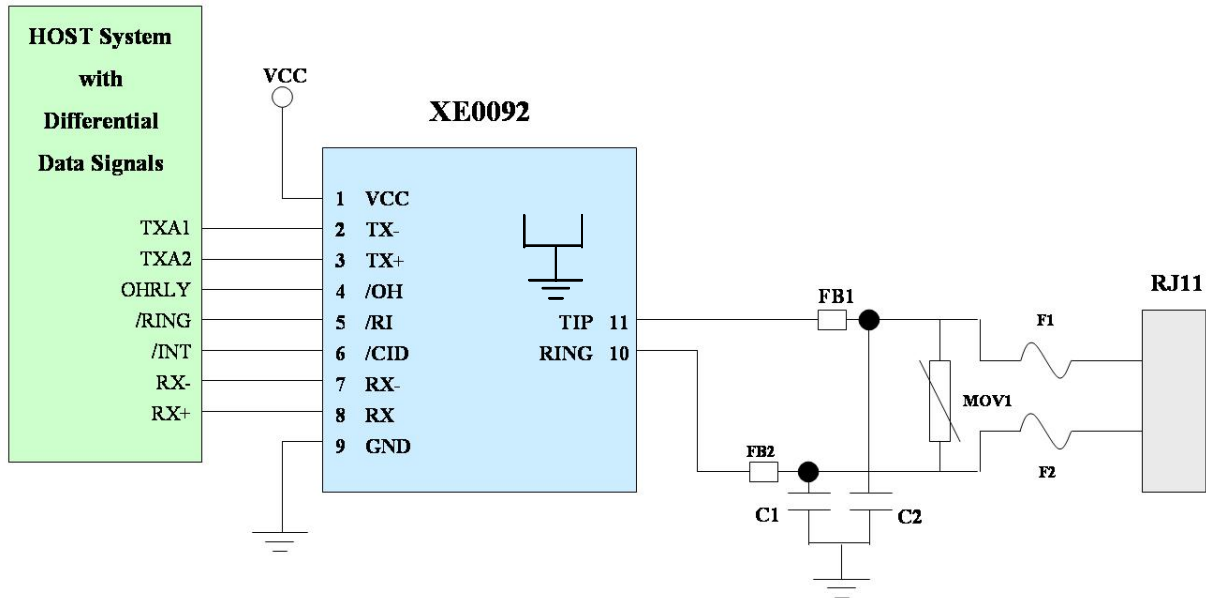

Component Description

- C1, C2 470 pFd, minimum 1500 Volts; these capacitors may be required for EMI filtering to prevent unintended radiation when the telephone cable is attached to your system. These capacitors must be rated at a minimum of 1500 volts to maintain the isolation required by FCC Part 68 Rules.
- FB1, FB2 FB1 and FB2 are ferrite beads which may be required for EMI filtering to prevent unintended radiation when the telephone cable is attached to your system. Cermetek recommends the TDK ACB2012L-120 which provides more than 100 ohms impedance at frequencies above 100 MHz.
- MOV1 MOV1 protects against damage from lightening strikes on the telephone lines. Cermetek recommends the Teccor P3100BA Sidactor to provide this protection.
- F1, F2 F1 and F2 prevent damage to the system when a power line crosses with the telephone line. Cermetek recommends the Raychem TR600-150 for this function. The TR600-150 is a PTC device which automatically resets after use.

XE0092 Surface-Mount PCB Layout Recommendations

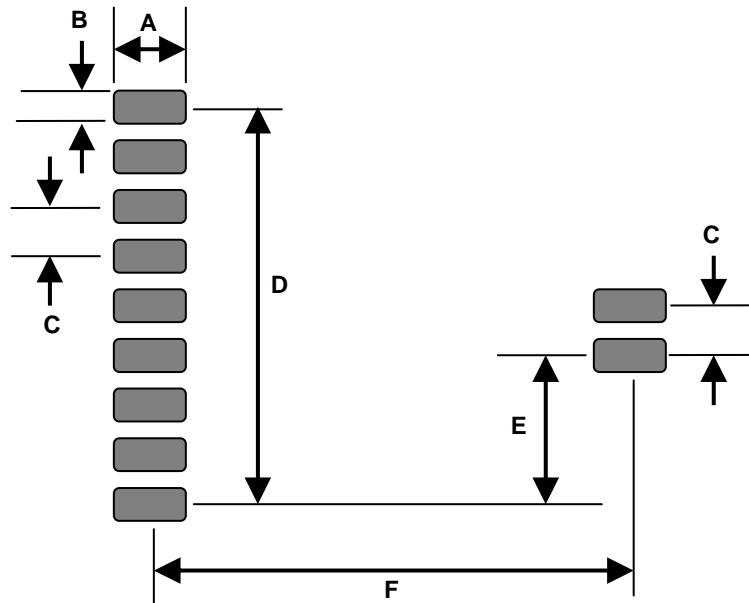

| Dimensions | Typical (Inches) | Description |
|------------|------------------|--|
| A | 0.10 | Pad Length |
| B | 0.06 | Pad Width |
| C | 0.10 | Space between adjacent pads |
| D | 0.80 | Distance from Pin 1 to Pin 9 |
| E | 0.30 | Vertical Distance from Pin 9 to Pin 10 |
| F | 1.20 | Row to Row Spacing |

Note: No components or traces should be placed under the XE0092LCC module.

XE0092 Surface-Mount Soldering Instructions

The XE0092 is subject to damage if over-exposed to heat during solder reflow operations. Following the soldering instructions below will ensure that the process of soldering the module to the board does not damage the modem.

| | |
|--------------------------------------|-------------|
| Maximum Temperature | 250° C |
| Maximum Time above 235° C | 15 Seconds |
| Maximum Time in reflow zone (217° C) | 90 Seconds |
| Maximum Preheat Dwell Time | 180 Seconds |

XE0092 Maximum Solder Temperature Profile

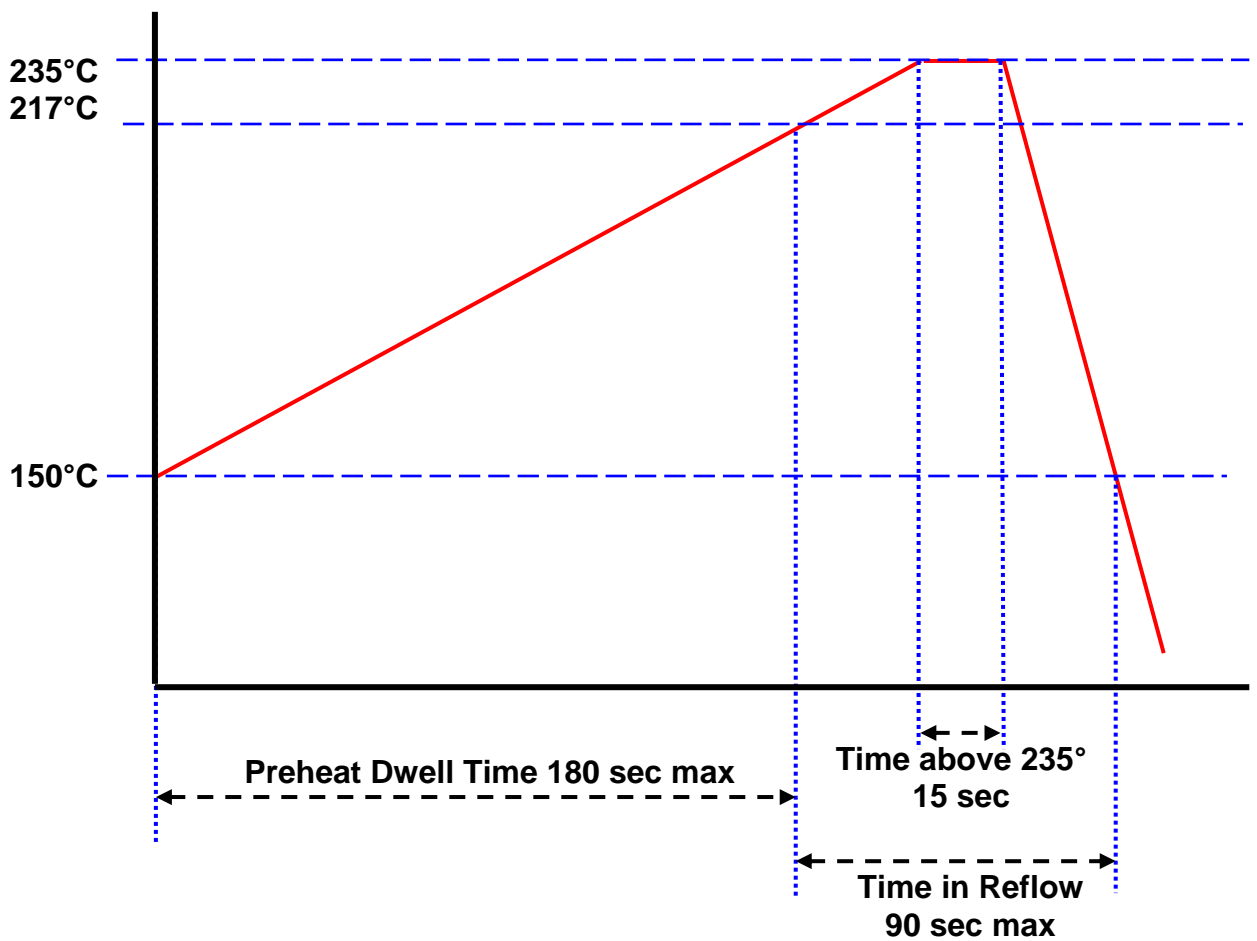

XE0092 ELECTRICAL SPECIFICATIONS

| Parameter | Conditions | Minimum | Typical | Maximum | Units |
|-----------------------------|---|--------------|------------|-----------|-----------|
| Power Supply voltage | | 3.0 | 3.3 | 5.0 | DC Volts |
| Power Supply Current | Off-hook On-hook | - - | 10 0.5 | - - | mA |
| Transhybrid Loss | 600 Ohm impedance, 1800 Hz | - | 40 | | dB |
| Transmit Insertion Loss | 600 Ohm impedance, 1800 Hz | -0.2 | 0 | 0.2 | dB |
| Receive Insertion Loss | 600 Ohm impedance, 1800 Hz | -0.2 | 0 | 0.2 | dB |
| Line Impedance | Off-Hook | - | 600 | - | Ohms |
| Second Harmonic Distortion | 600 ohms, 200 to 4000 Hz | - | -80 | - | dB |
| Ring Detect Sensitivity | Measured Across Tip & Ring, Type B Ringer | 28 | 90 | 150 | Vrms |
| RI Output Voltage | Ring Present No Ring Signal | - Vcc-0.4 | - - | 0.4 - | Volts |
| Hook Switch Control Voltage | On: (off-hook) Off: (on-hook) | - 2.0 | 0.2 3.0 | 0.5 - | Volts |
| Hook Switch Control Current | On: (off-hook) Off: (on-hook) | - -120 | - - | -120 - | microamps |
| Loop Current | Off-Hook | 10 | - | 100 | mA |
| DC On-Hook Impedance | Hook-Switch Open | 10 | - | - | MOhms |

XE0092 ABSOLUTE MAXIMUM RATINGS

Storage Temperature -40° C to +125° C

Operating Temperature Range * 0° C to +85° C

* The XE0092 can be ordered with an Operating Temperature of -40° C to +85° C at extra cost. Products tested to the higher temperature standard will be marked as -ITR.

XE0092 MECHANICAL SPECIFICATIONS

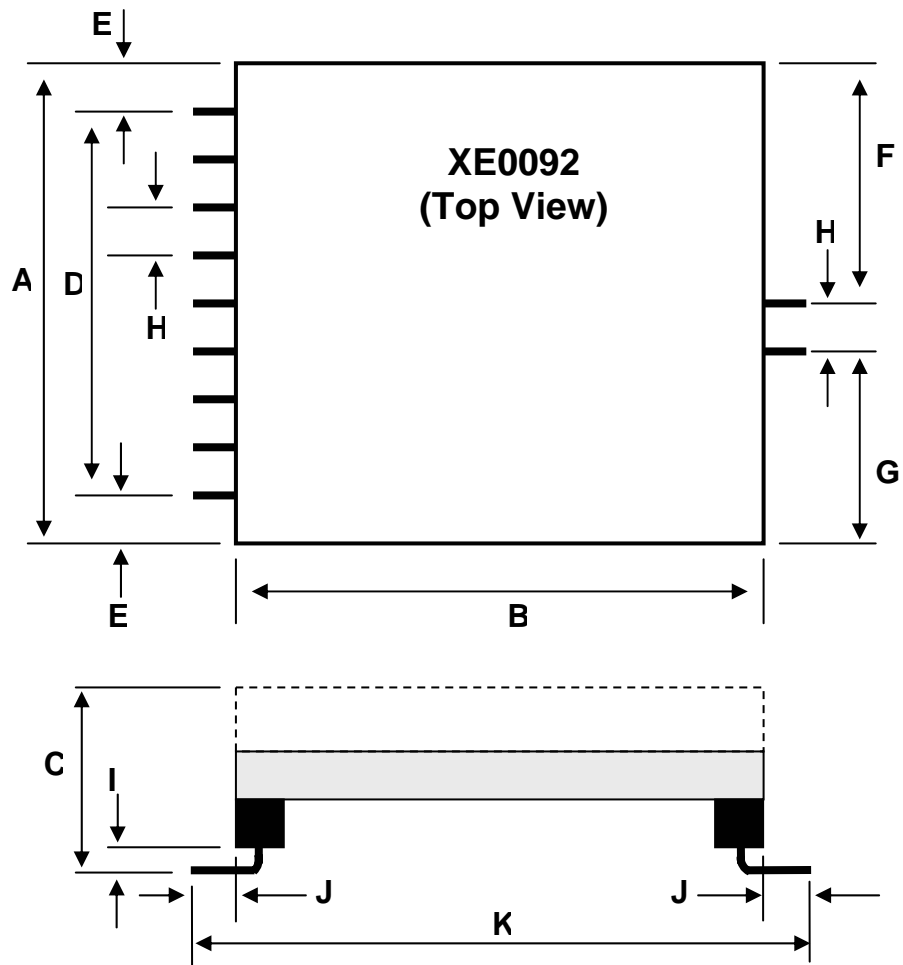

| Dimensions | Inches | Millimeters | Description |
|------------|--------|-------------|---|
| A | 1.00 | 25.40 | Product Length |
| B | 1.20 | 30.48 | Product Width |
| C | 0.30 | 7.62 | Product Height at the tallest component |
| D | 0.80 | 20.32 | Pin Row length Pin 1 to Pin 9 |
| E | 0.10 | 2.54 | Distance from Pin 1 or Pin 9 to the edge of the product |
| F | 0.50 | 12.70 | Distance from Pin 11 to the Edge of the product |
| G | 0.40 | 10.16 | Distance from Pin 10 to the Edge of the product |
| H | 0.10 | 2.54 | Distance between adjacent pins |
| I | 0.05 | 1.27 | Total height of the interface pin |
| J | 0.05 | 1.27 | Distance the pin extends beyond the product edge |
| K | 1.30 | 33.02 | Total distance across the product including pin spread |

NOTE: All interface pins are 0.25 inches square, Gold plated.

XE0092LCC MECHANICAL SPECIFICATIONS

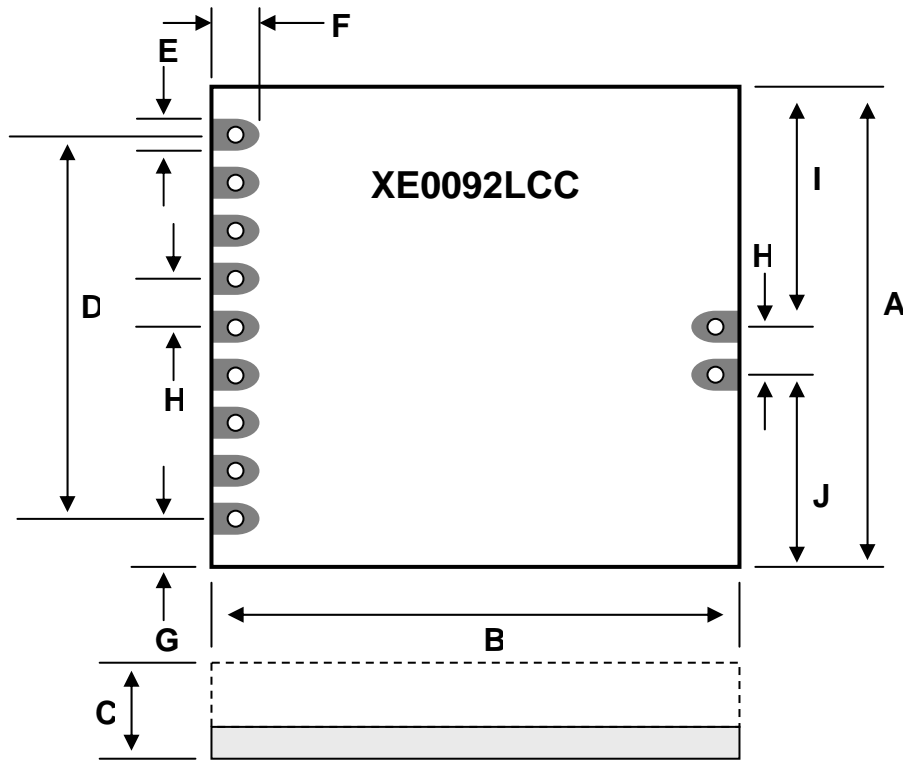

| Dimensions | Inches | Millimeters | Description |
|------------|--------|-------------|---|
| A | 1.00 | 25.40 | Product Length |
| B | 1.20 | 30.48 | Product Width |
| C | 0.15 | 3.81 | Product Height at the tallest component |
| D | 0.80 | 20.32 | Pin Row length Pin 1 to Pin 9 |
| E | 0.05 | 1.27 | Width of Solder Pad |
| F | 0.075 | 1.90 | Length of Solder Pad |
| G | 0.10 | 10.16 | Distance from Pin 1 or 9 to the Edge of the product |
| H | 0.10 | 2.54 | Distance between adjacent pins |
| I | 0.50 | 1.27 | Distance from Pin 11 to the Edge of the product |
| J | 0.40 | 1.27 | Distance from Pin 10 to the Edge of the product |

XE0092LCC MECHANICAL SPECIFICATIONS

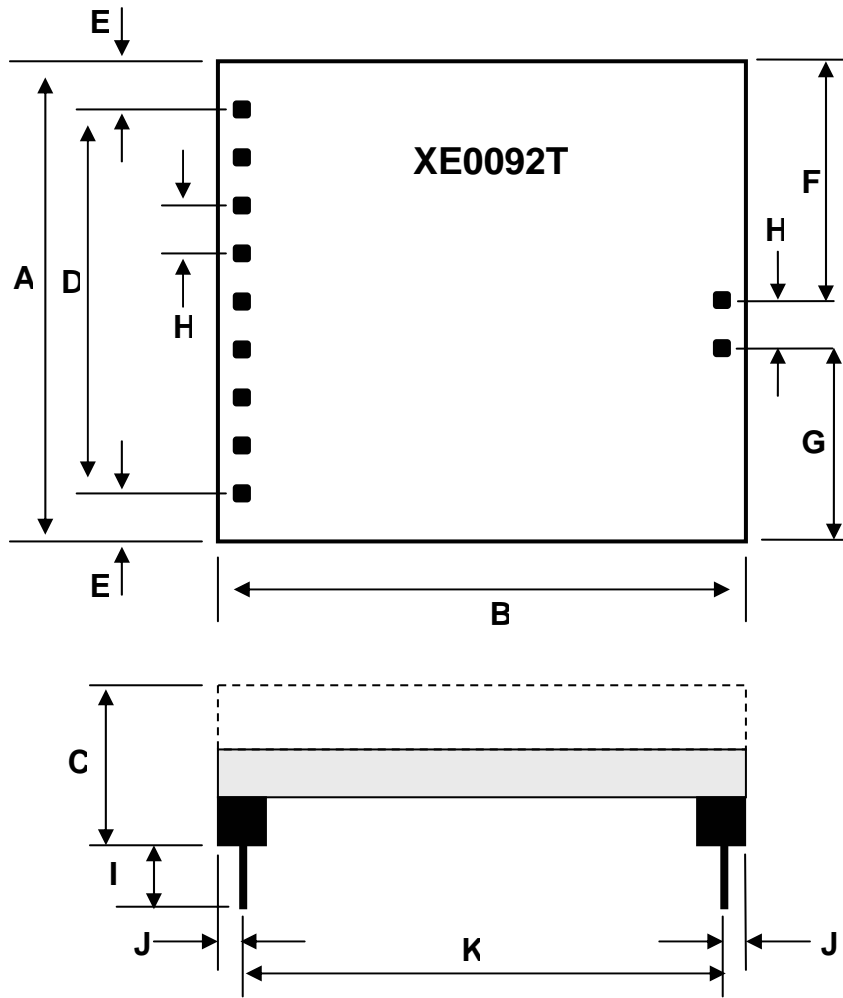

| Dimensions | Inches | Millimeters | Description |
|------------|--------|-------------|---|
| A | 1.00 | 25.40 | Product Length |
| B | 1.20 | 30.48 | Product Width |
| C | 0.30 | 7.62 | Product Height at the tallest component |
| D | 0.80 | 20.32 | Pin Row length Pin 1 to Pin 9 |
| E | 0.10 | 2.54 | Distance from Pin 1 or Pin 9 to the edge of the product |
| F | 0.50 | 12.70 | Distance from Pin 11 to the Edge of the product |
| G | 0.40 | 10.16 | Distance from Pin 10 to the Edge of the product |
| H | 0.10 | 2.54 | Distance between adjacent pins |
| I | 0.15 | 3.81 | Total height of the interface pin |
| J | 0.05 | 1.27 | Distance the pin extends beyond the product edge |
| K | 1.10 | 27.94 | Distance between Pin Rows |

NOTE: All interface pins are 0.25 inches square, Gold plated.

FCC part 68 Information

When developing a product to be connected to the telephone line, it is necessary to use a circuit known as a Data Access Arrangement (DAA) approved by the appropriate governmental agency. In the US this agency is the Federal Communications Commission (FCC), while in Canada it is Industry Canada (IC). These agencies test and approve the product to ensure that it meets their specifications, thereby protecting the telephone system from damage and protecting the user from high voltage transients (such as lightning strikes) which may come down the telephone line.

The XE0092 has been designed to meet all FCC Part 68 requirements for hazardous voltage, line impedance and leakage current. If the system transmits data, synthesized voice, or DTMF tones on the telephone line, the user must certify that the signals transmitted meet basic FCC requirements for maximum transmission levels, out of band energy and billing delay. Full details may be obtained from the FCC under Part 68 of the FCC Rules and Regulations, or in Title 47 of the Code of Federal Regulations, however the basic requirements are as follows:

1. Maximum Transmit Level

For the normal "permissive" (standard) telephone line, equipment which transmits data (such as a modem) must not exceed a transmission level of -9 dBm.

2. Out of Band Energy

Data equipment must not transmit "out of band" energy on the telephone line which exceeds the following limits:

| Frequency | Range | Max. Power |
|-----------|------------|------------|
| 3995 Hz | to 4005 Hz | -27 dBm |
| 4005 Hz | to 12 kHz | -20 dBm |
| 12 kHz | to 90 kHz | -55 dBm |
| 90 kHz | to 270 kHz | -55 dBm |
| 270 kHz | to 6 MHz | -15 dBm |

3. DTMF Transmission Level

If the system is capable of DTMF dialing, the maximum DTMF transmission level must be less than 0 dBm averaged over a 3 second interval.

4. Billing Delay

A delay of 2 seconds or greater is required after the time the XE0092 is taken "off hook" and before any information is transmitted. This is required to ensure that billing information may be exchanged between telephone company central offices without interference.

The user of the XE0092 must certify to the FCC that the final system meets the requirements of Part 68 which include the criteria above as well as the high voltage protection provided by the XE0092. This is generally accomplished through an independent testing lab which tests the System and submits the proper paperwork to the FCC for approval. Since the XE0092 already complies with FCC Part 68 rules, this is a relatively simple process.

Model Numbers

Cermetek offers a several variations of the XE0092. Variants include surface-mount pins, through-hole pins and no pins. All pin variations are available in the standard 0° to 70° C operating range or in an extended operating temperature range of -40° to +85° C. The table below lists the available XE0092 models.

XE0092 Model Numbers

| Model | Summary of Features |
|----------------------|--|
| XE0092 | Low cost DAA for voice or data with surface-mount leads, 0° to 70° C operation |
| XE0092LCC | Low cost, Leadless DAA for voice or data, 0° to 70° C operation |
| XE0092T | Low cost DAA for voice or data with through-hole leads, 0° to 70° C operation |
| XE0092-ITR | Low cost DAA for voice or data with surface-mount leads, -40° to 85° C operation |
| XE0092LCC-ITR | Low cost, Leadless DAA for voice or data, -40° to 85° C operation |
| XE0092T-ITR | Low cost DAA for voice or data with through-hole leads, -40° to 85° C operation |

Terms of Sale

Devices sold by Cermetek are covered by the warranty provisions appearing in its Terms of Sale only. Cermetek makes no warranty, express, statutory, implied, or by description regarding the information set forth herein, or regarding the freedom of the described devices from patent infringement. Cermetek makes no warranty of merchantability or fitness for any purposes. Cermetek reserves the right to discontinue production and change specifications and prices at any time and without notice. This product is intended for use in normal commercial applications. Applications requiring extended temperature range, unusual environmental requirements, or high reliability applications, such as military, medical life-support or life-sustaining equipment, are specifically not recommended without additional processing and authorization by Cermetek for such application.

Life Support Policy

Cermetek products are not authorized for use as Critical Components in Life Support Devices or Systems.

Life Support Devices or Systems are devices or systems which, (a) are intended for surgical implant into the body, or (b) support or sustain life, and whose failure to perform, when properly used in accordance with instructions provided in the labeling, can be reasonably expected to result in significant injury to the user.

A Critical Component is any component of a life support device or system whose failure to perform can be reasonably expected to cause failure of the life support device or system, or to affect its safety or effectiveness.

Cermetek reserves the right to make changes in specifications at any time and without notice. The information furnished by Cermetek in this publication is believed to be accurate and reliable. However, Cermetek assumes no responsibility for its use, or for any infringements of patents or other rights of third parties resulting from its use. No license is granted under any patents or patent rights of Cermetek.

Cermetek provides the user with a FCC (USA) Approved module. However, Cermetek does not have influence over nor knowledge of the specific user application environment. Therefore, for FCC Approved or Approvable devices, the user assumes all risk for maintaining compliance to registration.

Printed in U.S.A