

# DuSLIC-SP

Single Package - Dual-Channel Subscriber Line Interface Controller  
PEB 3268



The DuSLIC-SP is the newest member of Infineon's Dual-channel Subscriber Line Interface Controllers (DuSLIC) product family. The single package DuSLIC-SP implements a dual-channel telephone line interface to provide all the necessary voice interface functions from the high voltage subscriber line to the  $\mu$ C/DSP digital interface. A single package solution only 256 mm<sup>2</sup> in size, DuSLIC-SP reduces the line interface unit footprint by up to 40% compared to multi-chip solutions currently on the market.

DuSLIC-SP targets POTS and the fast growing VoIP customer equipment market where competition and price erosion make time-to-market and system cost reduction critical issues. Fully programmable and featuring two integrated DC/DC converters, DuSLIC-SP incorporates all the advanced feature-set of Infineon's market leading SLIC/CODEC solutions into one highly integrated system-on-chip.

Building on Infineon's proven technological expertise, DuSLIC-SP makes the design of VoIP enabled devices much simpler, while reducing development time and efforts as well as the overall bill-of-material (BOM).

## Analog Line Interface Applications

- Customer Premises Equipment (CPE)
- ISDN CPE
- XDSL CPE
- Analog Telephone Adaptors (ATA)
- VoIP Gateways and Routers
- Media Terminal Adapters (MTA)
- Integrated Access Devices (IAD)
- Cable modem

## Features

- Specification according to ITU-T Q.552, G.712, LSSGR
- Fully programmable dual-channel CODEC
- Two programmable on-chip tone generators
- Programmable thresholds: on-hook, off-hook, ring trip detection
- Programmable DC feeding

- Constant current feed 0 - 50 mA
- Constant voltage zone
- Programmable resistive zone
- Internal balanced ringing with integrated DC/DC converter
- Up to 65 V<sub>rms</sub> sinusoidal ringing
- Patented Ring mode allows significant power reduction
- Minimized external component count in order to enable high board density design
- Low cost BOM

## Extended Features

- Power management capability
- Modem optimized mode (true 56 kbit/s)
- DTMF generation
- On-hook data transmission for always-on capability
- Message waiting indication

[www.infineon.com/duslic](http://www.infineon.com/duslic)

Communication Solutions



Never stop thinking

## DuSLIC-SP Block Diagram

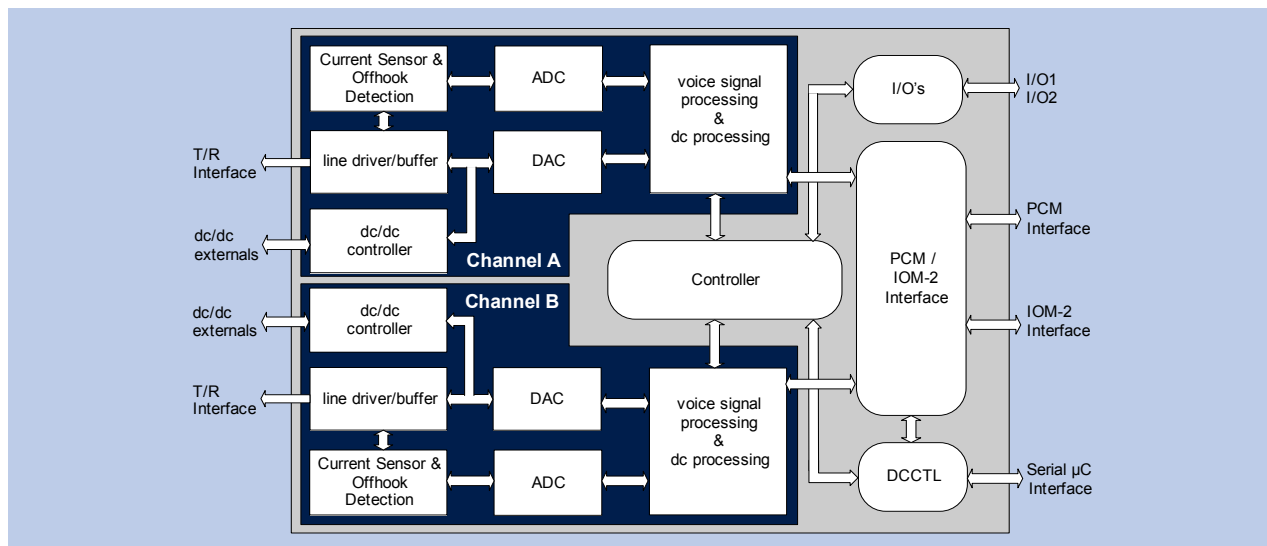

## Product Summary

Sales Code	Description	Package
PEB3268F	DuSLIC-SP, Dual Channel Subscriber Line Interface Circuit in a Single Package	P/PG-TQFP-100-9
EASY 3268	DuSLIC-SP Tool Package including SMART 2000	
SMART 3268	DuSLIC-SP Evaluation Board	

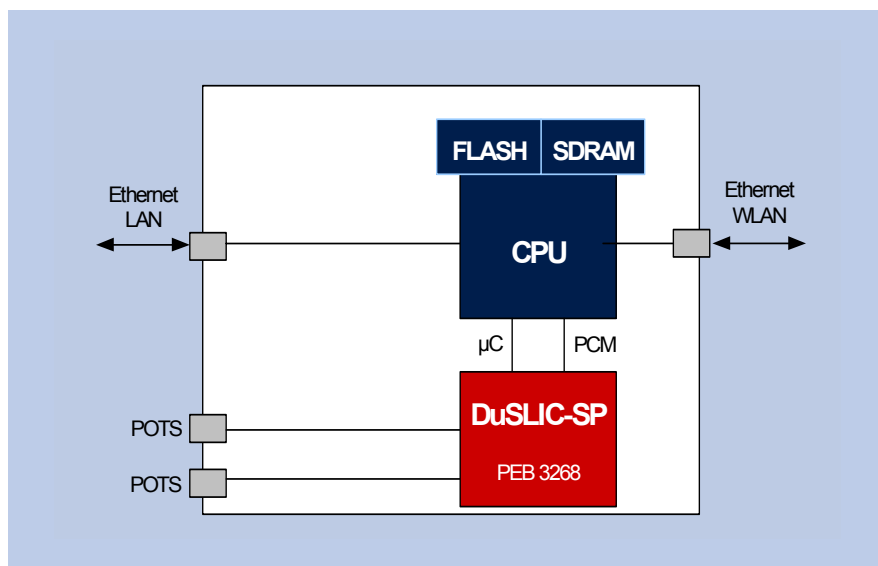

## Application Example: Analog Terminal Adapter

### How to reach us:

<http://www.infineon.com>

Published by  
**Infineon Technologies AG**  
 81726 München, Germany

© Infineon Technologies AG 2006.  
 All Rights Reserved.

### Legal Disclaimer

The information given in this Product Brief shall in no event be regarded as a guarantee of conditions or characteristics ("Beschaffensgarantie"). With respect to any examples or hints given herein, any typical values stated herein and/or any information regarding the application of the device, Infineon Technologies hereby disclaims any and all warranties and liabilities of any kind, including without limitation warranties of non-infringement of intellectual property rights of any third party.

### Information

For further information on technology, delivery terms and conditions and prices please contact your nearest Infineon Technologies Office ([www.infineon.com](http://www.infineon.com)).

### Warnings

Due to technical requirements components may contain dangerous substances. For information on the types in question please contact your nearest Infineon Technologies Office. Infineon Technologies Components may only be used in life-support devices or systems with the express written approval of Infineon Technologies, if a failure of such components can reasonably be expected to cause the failure of that life-support device or system, or to affect the safety or effectiveness of that device or system. Life support devices or systems are intended to be implanted in the human body, or to support and/or maintain and sustain and/or protect human life. If they fail, it is reasonable to assume that the health of the user or other persons may be endangered.