



# STLC3075

## Integrated POTS interface for home access gateway and WLL

### Features

- Monochip SLIC optimized for WLL & VoIP applications
- Implements all Borsht function key features
- Single supply (4.5 V to 12 V) for fly-back configuration
- Single supply (5.5 V to 12 V) for buck-boost configuration
- Built in DC/DC converter controller
- Soft battery reversal with programmable transition time
- On-hook transmission
- Programmable off-hook detector threshold
- Metering pulse generation and filter
- Integrated ringing
- Integrated ring trip
- Parallel control interface (3.3 V logic level)
- Programmable constant current feed
- Surface mount package
- Integrated thermal protection
- Dual gain value option
- Automatic recognition flyback and buckboost configuration
- BCDIIS 90V technology
- -40 °C to +85 °C operating range

### Description

The STLC3075 is a SLIC device specifically designed for WLL (Wireless Local Loop), and ISDN terminal adaptors and VoIP applications. One distinctive characteristic of this device is its ability to operate with a single supply voltage (from +4.5 V to +12 V) and to self generate the negative battery by means of an on-chip DC/DC converter controller that drives an external MOS switch.

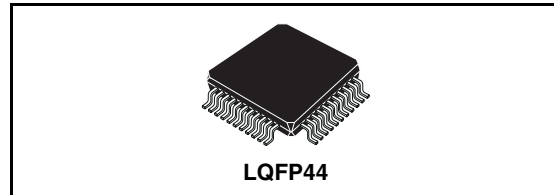

The battery level is properly adjusted depending on the operating mode. A useful characteristic for these applications is the integrated ringing generator.

The control interface is parallel with open drain output and 3.3 V logic levels.

The metering pulses are generated on-chip starting from two logic signals (0 and 3.3 V): one signal defining the metering pulse frequency, the other signal defining the metering pulse duration. An on-chip circuit then provides the proper shaping and filtering. Metering pulse amplitude and shaping (rising and decay time) can be programmed by external components.

A dedicated cancellation circuit avoids possible codec input saturation due to metering pulse echo.

Constant current feed can be set from 20 mA to 40 mA. Off-hook detection threshold is programmable from 5 mA to 9 mA.

The device, which is developed in BCDIIS technology (90 V process), operates in the extended temperature range and integrates a thermal protection that sets the device in power down when  $T_j$  exceeds 140 °C.

**Table 1. Device summary**

Order code	Package	Packing
E-STLC3075 <sup>(1)</sup>	LQFP44	Tray

1. ECOPACK® (see [Section 9](#))

# Contents

<b>1</b>	<b>Block diagram</b> .....	<b>5</b>
<b>2</b>	<b>Pin description</b> .....	<b>6</b>
<b>3</b>	<b>Electrical specification</b> .....	<b>8</b>
3.1	Absolute maximum rating .....	8
3.2	Operating range .....	8
3.3	Thermal data .....	8
<b>4</b>	<b>Functional description</b> .....	<b>9</b>
4.1	DC/DC converter .....	9
4.2	Operating modes .....	10
4.2.1	Power down .....	10
4.2.2	High impedance feeding (HI-Z) .....	10
4.2.3	Active .....	11
4.2.4	Ringling .....	14
<b>5</b>	<b>Application information</b> .....	<b>16</b>
5.1	Layout recommendation .....	16
5.2	External components list .....	16
<b>6</b>	<b>Electrical characteristics</b> .....	<b>25</b>
6.1	Test circuits .....	28
<b>7</b>	<b>Over voltage protection</b> .....	<b>32</b>
<b>8</b>	<b>Typical state diagram</b> .....	<b>33</b>
<b>9</b>	<b>Package information</b> .....	<b>34</b>
<b>10</b>	<b>Revision history</b> .....	<b>35</b>

## List of tables

Table 1.	Device summary . . . . .	1
Table 2.	Pin description . . . . .	6
Table 3.	Absolute maximum ratings . . . . .	8
Table 4.	Operating range . . . . .	8
Table 5.	Thermal data. . . . .	8
Table 6.	SLIC operating modes . . . . .	9
Table 7.	Gain set in active mode . . . . .	12
Table 8.	SLIC states in active mode . . . . .	12
Table 9.	CREST factor values @ 20 and 25Hz . . . . .	14
Table 10.	External components for buckboost configuration . . . . .	17
Table 11.	VBAT values in RING and ACTIVE modes . . . . .	18
Table 12.	External components for flyback configuration . . . . .	19
Table 13.	Coilcraft type FA2469-AL electrical specifications . . . . .	20
Table 14.	Coilcraft type FA2470-AL electrical specifications . . . . .	20
Table 15.	External components @gain set = 0. . . . .	21
Table 16.	External components @gain set = 1. . . . .	22
Table 17.	Electrical characteristics . . . . .	25
Table 18.	Document revision history . . . . .	35

## List of figures

Figure 1.	Block diagram . . . . .	5
Figure 2.	Pin connection (top view) . . . . .	6
Figure 3.	DC characteristics in HI-Z mode. . . . .	10
Figure 4.	DC characteristics in active mode . . . . .	11
Figure 5.	TIP/RING typical transition from direct to reverse polarity . . . . .	12
Figure 6.	Metering pulse generation circuit . . . . .	13
Figure 7.	TIP/RING typical ringing waveform. . . . .	14
Figure 8.	Application diagram with N-channel . . . . .	23
Figure 9.	Application diagram without metering pulse generation with N-channel. . . . .	23
Figure 10.	Application diagram with P-channel . . . . .	24
Figure 11.	Application diagram without metering pulse generation . . . . .	24
Figure 12.	2W return loss $2WRL = 20\text{Log}( Z_{ref} + Z_s / Z_{ref} - Z_s ) = 20\text{Log}(E/2V_s)$ . . . . .	28
Figure 13.	THL trans hybrid loss $THL = 20\text{Log} V_{rx}/V_{tx} $ . . . . .	29
Figure 14.	G24 transmit gain $G_{24} = 20\text{Log} 2V_{tx}/E $ . . . . .	29
Figure 15.	G42 receive gain $G_{42} = 20\text{Log} V_l/V_{rx} $ . . . . .	29
Figure 16.	PSRRC power supply rejection VPOS to 2W port $PSSRC = 20\text{Log} V_n/V_l $ . . . . .	30
Figure 17.	L/T longitudinal to transversal conversion $L/T = 20\text{Log} V_{cm}/V_l $ . . . . .	30
Figure 18.	T/L transversal to longitudinal conversion $T/L = 20\text{Log} V_{rx}/V_{cm} $ . . . . .	30
Figure 19.	VTTX metering pulse level on line . . . . .	31
Figure 20.	V2Wp and W4Wp: Idle channel sophometric noise at line and TX. $V_{2Wp} = 20\text{Log} V_l/0.774I $ ; $V_{4Wp} = 20\text{Log} V_{tx}/0.774I $ . . . . .	31
Figure 21.	Simplified configuration for indoor over voltage protection . . . . .	32
Figure 22.	Standard over voltage protection configuration for K20 compliance . . . . .	32
Figure 23.	Typical state diagram for STLC3075 operation . . . . .	33
Figure 24.	LQFP44 (10 x 10 x 1.4 mm) mechanical data and package dimensions . . . . .	34

# 1 Block diagram

Figure 1. Block diagram

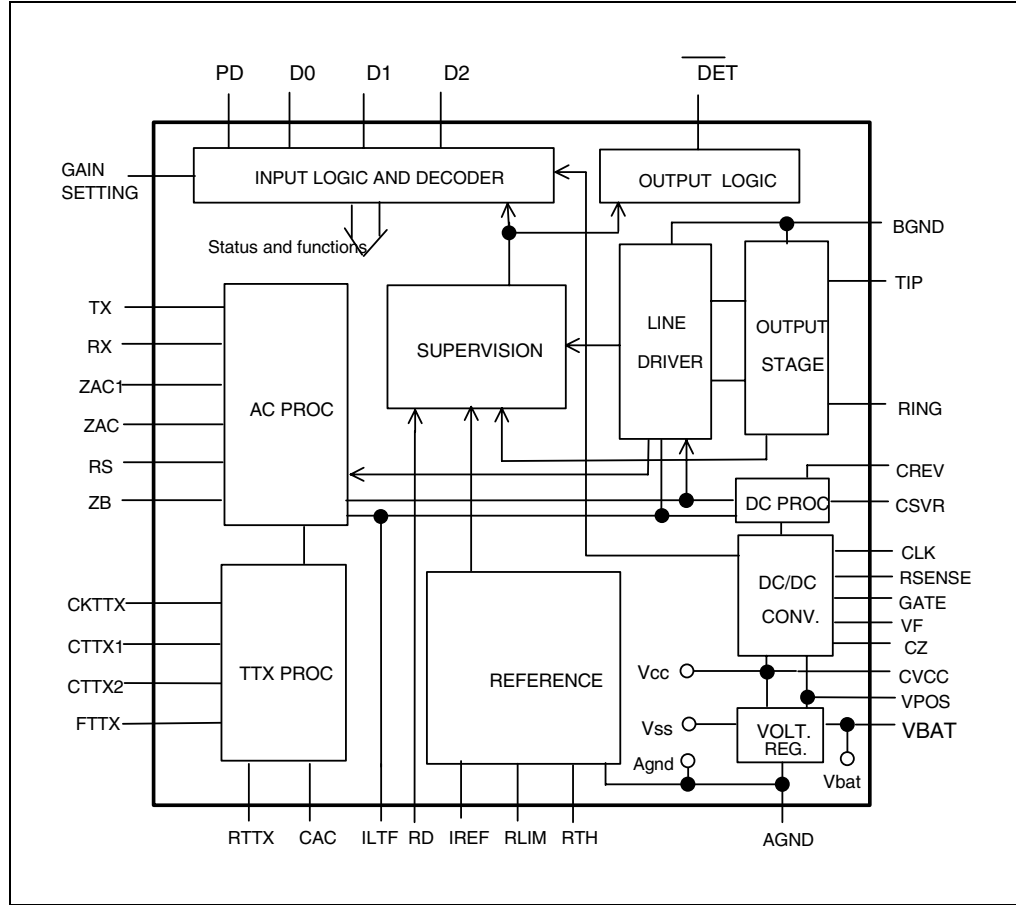

## 2 Pin description

Figure 2. Pin connection (top view)

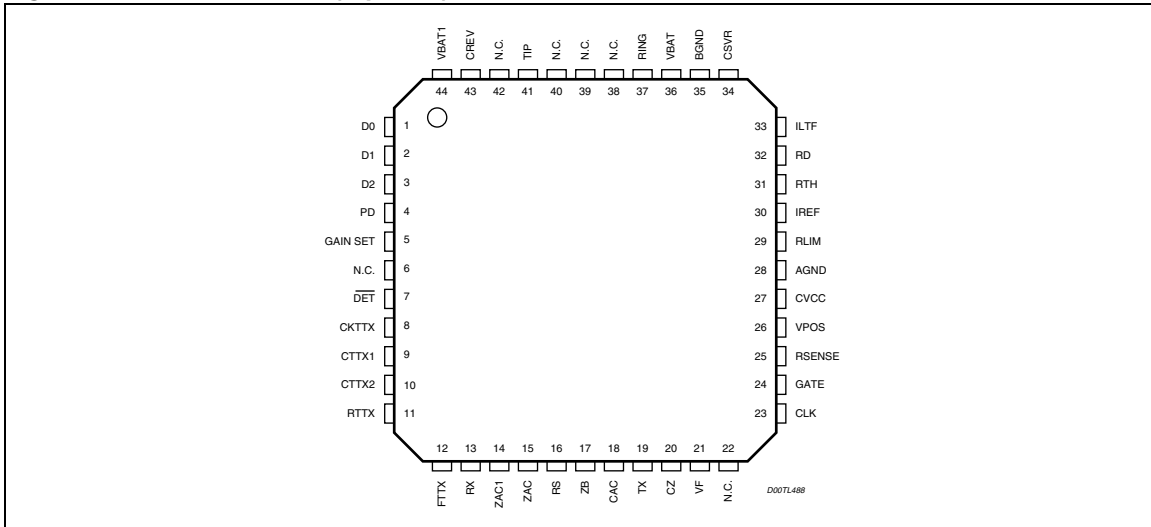

Table 2. Pin description

N°	Pin	Function
1	D0	Control interface: input bit 0
2	D1	Control interface: input bit 1
3	D2	Control interface: input bit 2
4	PD	Power down input. Normally connected to CVCC (or to logic level high)
5	Gain SET	Control gain interface: 0 Level $R_{xgain} = 0\text{dB}$ $T_{xgain} = -12\text{dB}$ 1 Level $R_{xgain} = +6\text{dB}$ $T_{xgain} = -12\text{dB}$
6, 22, 38, 39, 40, 42	NC	Not connected
7	DET	Logic interface output of the supervision detector (active low)
8	CKTTX	Metering pulse clock input (12 kHz or 16 kHz square wave)
9	CTTX1	Metering burst shaping external capacitor
10	CTTX2	Metering burst shaping external capacitor
11	RTTX	Metering pulse cancellation buffer output. TTX filter network should be connected to this point. If not used, should be left open.
12	FTTX	Metering pulse buffer input this signal is sent to the line and used to perform TTX filtering
13	RX	4 wires input port (RX input). A 100 k $\Omega$ external resistor must be connected to AGND via the bias input stage. This signal refers to AGND. If connected to single supply CODEC output it must be DC decoupled with proper capacitor.
14	ZAC1	RX buffer output (the AC impedance is connected from this node to ZAC)
15	ZAC	AC impedance synthesis

Table 2. Pin description (continued)

N°	Pin	Function
16	RS	Protection resistors image (the image resistor is connected from this node to ZAC)
17	ZB	Balance network for 2 to 4 wire conversion (the balance impedance ZB is connected from this node to AGND. ZA impedance is connected from this node to ZAC1).
18	CAC	AC feedback input, AC/DC split capacitor (CAC)
19	TX	4 wire output port (TX output). The signal is referred to AGND. If connected to single supply CODEC input it must be DC decoupled with proper capacitor.
20	CZ	Flyback compensation
21	VF	Feedback input for DC/DC converter controller
23	CLK	Power switch controller clock (typ. 125 kHz). This pin can also be connected to CVCC or AGND. When the CLK pin is connected to CVCC an internal auto-oscillation is internally generated and it is used instead of the external clock. When the CLK pin is connected to AGND, the GATE output is disabled.
24	GATE	Driver for external power MOS transistor (P-channel in buckboost configuration, N-channel in flyback configuration).
25	R <sub>SENSE</sub>	Voltage input for current sensing. R <sub>SENSE</sub> resistor should be connected close to this pin and V <sub>POS</sub> pin (Buckboost) or GND (Flyback). The PCB layout should minimize the extra resistance introduced by the copper tracks.
26	V <sub>POS</sub>	Positive supply input
27	CVCC	Internal positive voltage supply filter
28	AGND	Analog ground. Must be shorted with BGND.
29	RLIM	Constant current feed programming pin (via RLIM). RLIM should be connected close to this pin and AGND pin to avoid noise injection.
30	IREF	Internal bias current setting pin. RREF should be connected close to this pin and AGND pin to avoid noise injection.
31	RTH	Off-hook threshold programming pin (via RTH). RTH should be connected close to this pin and AGND pin to avoid noise injection.
32	RD	DC feedback and ring trip input. RD should be connected close to this pin and AGND pin to avoid noise injection.
33	ILTF	Transversal line current image output
34	CSVR	Battery supply filter capacitor
35	BGND	Battery ground, must be shorted with AGND
36	VBAT	Regulated battery voltage self generated by the device via DC/DC converter. Must be shorted to VBAT1.
37	RING	2 wire ports; RING wire (I <sub>b</sub> is the current sunk into this pin)
41	TIP	2 wire ports; TIP wire (I <sub>a</sub> is the current sourced from this pin)
43	CREV	Reverse polarity transition time control. A proper capacitor connected between this pin and AGND is setting the reverse polarity transition time. This is the same transition time used to shape the 'trapezoidal ringing' during ringing injection.
44	VBAT1	Frame connection. Must be shorted to VBAT

## 3 Electrical specification

### 3.1 Absolute maximum rating

**Table 3. Absolute maximum ratings**

Symbol	Parameter	Value	Unit
$V_{POS}$	Positive supply voltage	-0.4 to +13	V
A/BGND	AGND to BGND	-1 to +1	V
$V_{dig}$	Pin D0, D1, D2, $\overline{DET}$ , CKTTX	-0.4 to 5.5	V
$T_j$	Max. junction temperature	150	°C
$V_{btot}^{(1)}$	$V_{btot}= V_{POS} + V_{bat} $ . (Total voltage applied to the device supply pins).	90	V
ESD rating	Human body model	±1750	V
	Charged device model	±500	V

1.  $V_{bat}$  is self generated by the on-chip DC/DC converter and can be programmed via RF1 and RF2. RF1 and RF2 must be selected in order to fulfil the a.m. limits (see components tables).

### 3.2 Operating range

**Table 4. Operating range**

Symbol	Parameter	Value	Unit
$V_{POS}$	Positive supply voltage	4.5 to +12	V
A/BGND	AGND to BGND	-100 to +100	mV
$V_{dig}$	Pin D0, D1, D2, $\overline{DET}$ , CKTTX, PD	-0.25 to 5.25	V
$T_{op}$	Ambient operating temperature range	-40 to +85	°C
$V_{bat}^{(1)}$	Self generated battery voltage	-74 max.	V

1.  $V_{bat}$  is self generated by the on-chip DC/DC converter and can be programmed via RF1 and RF2. RF1 and RF2 must be selected in order to fulfil the a.m. limits (see [Table 10: External components for buckboost configuration](#))

### 3.3 Thermal data

**Table 5. Thermal data**

Symbol	Parameter	Value	Unit
$R_{th\ j-amb}$	Thermal resistance junction to ambient typical.	60	°C/W



## 4 Functional description

The STLC3075 is a device specifically developed for WLL VoIP and ISDN-TA applications. It is based on a SLIC core, on purpose optimized for these applications, with the addition of a DC/DC converter controller to meet the WLL and ISDN-TA design requirements.

The SLIC performs the standard feeding, signalling and transmission functions.

STLC3075 can be set in three different operating modes via the D0, D1, D2 pins of the control logic interface (0 to 3.3 V logic levels). The loop status is carried out on the  $\overline{\text{DET}}$  pin (active low).

The  $\overline{\text{DET}}$  pin is an open drain output to allow easy interfacing with both 3.3 V and 5 V logic levels.

The four possible SLIC's operating modes are:

- Power down
- High impedance feeding (HI-Z)
- Active
- Ringing

[Table 6](#) shows how to set the different SLIC operating modes.

**Table 6. SLIC operating modes**

PD	D0	D1	D2	Operating mode
0	0	0	X	Power down
1	0	0	X	H.I. feeding (HI-Z)
1	0	1	0	Active normal polarity
1	0	1	1	Active reverse polarity
1	1	1	0	Active TTX injection (N.P.)
1	1	1	1	Active TTX injection (R.P.)
1	1	0	0/1	Ring (D2 bit toggles @ fring)

### 4.1 DC/DC converter

The DC/DC converter controller drives an external power MOS transistor N-Ch plus transformer (Flyback configuration) or P-Ch plus inductor (Buckboost configuration), in order to generate the negative battery voltage needed for the device operation.

The DC/DC converter controller is synchronized with an external CLK (125 kHz typ.) or with an internal clock generated when the pin CLK is connected to CVCC. One  $R_{\text{SENSE}}$  in series to PGND supply (Flyback) or to  $V_{\text{POS}}$  supply (Buckboost) allows to fix the maximum allowed input peak current.

This feature is implemented in order to avoid overload on  $V_{\text{POS}}$  supply in case of line transient (ex. ring trip detection). The 110 m $\Omega$  typical value guarantees an average current consumption from  $V_{\text{POS}} < 700$  mA for buckboost configuration. The 220 m $\Omega$  typical value guarantees an average current consumption from  $V_{\text{POS}} < 800$  mA for flyback configuration.

The self generated battery voltage is set to a predefined value in on-hook state.

The typical value of -50 V can be adjusted via one external resistor (RF1). When RING mode is selected this typical value is increased to -70 V.

Once the line goes in off-hook condition, the DC/DC converter automatically adjusts the generated battery voltage in order to feed the line with a fixed DC current (programmable via RLIM) optimizing the power dissipation.

## 4.2 Operating modes

### 4.2.1 Power down

When this mode is selected the SLIC is switched off and the TIP and RING pins are in high impedance. The line detectors are also disabled therefore the off-hook condition cannot be detected.

The power down mode can be selected in emergency condition when it is necessary to cut any current delivered to the line.

The power down mode is also forced by STLC3075 in case of thermal overload ( $T_j > 140\text{ }^\circ\text{C}$ ). In this case the device goes back to the previous status as soon as the junction temperature decrease under the hysteresis threshold.

No AC transmission is possible.

### 4.2.2 High impedance feeding (HI-Z)

This operating mode is normally selected when the telephone is in on-hook in order to monitor the line status keeping the power consumption at the minimum.

The output voltage in on-hook condition is equal to the self generated battery voltage (-50 V typical).

When off-hook occurs the  $\overline{\text{DET}}$  becomes active (low logic level).

The off-hook threshold value in HI-Z mode is the same as the programmed value in ACTIVE mode.

The DC characteristics in HI-Z mode are equal to the self generated battery with  $2 \times (1600\ \Omega + R_p)$  in series (see [Figure 3](#)), where  $R_p$  is the external protection resistance.

No AC transmission is possible.

**Figure 3. DC characteristics in HI-Z mode.**

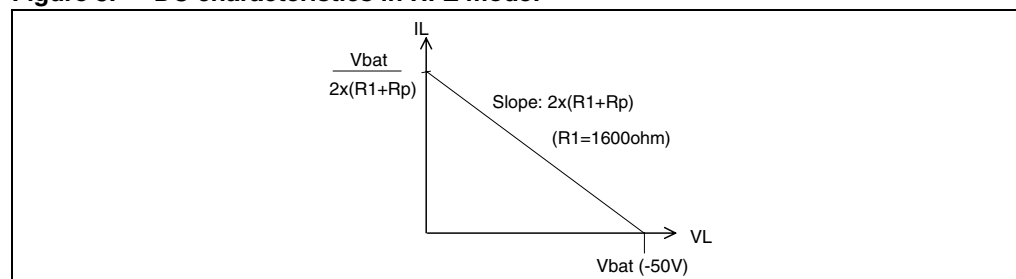

### 4.2.3 Active

#### DC characteristics & supervision

When this mode is selected the STLC3075 provides both DC feeding and AC transmission.

The STLC3075 feeds the line with a constant current fixed by RLIM (20 mA to 40 mA range). The on-hook voltage is typically 40 V allowing on-hook transmission; the self generated Vbat is -50 V typical.

If the loop resistance is very high and the line current cannot reach the programmed constant current feed value, the STLC3075 behaves like a 40 V voltage source with a series impedance equal to the protection resistors  $2 \times R_p$  (typ.  $2 \times 50 \Omega$ ). *Figure 4.* shows the typical DC characteristics in active mode.

The line status (on/off hook) is monitored by the SLIC'S supervision circuit. The off-hook threshold can be programmed via the external resistor RTH in the range from 5mA to 9mA.

Independently on the programmed constant current value, the TIP and RING buffers have a current source capability limited to 80mA typical.

**Figure 4. DC characteristics in active mode**

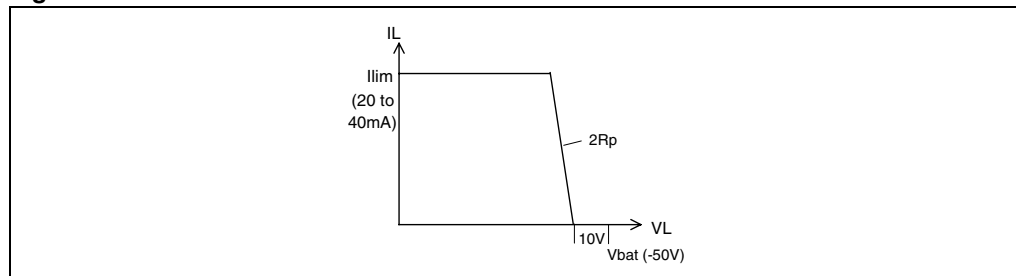

Moreover the power available at Vbat is controlled by the DC/DC converter that limits the peak current drawn from the  $V_{POS}$  supply. The maximum allowed current peak is set by  $R_{SENSE}$  resistor.

## AC characteristics

The SLIC provides the standard SLIC transmission functions.

Once in active mode the SLIC can operate with two different Tx, Rx gains set by the gain set control bit (See [Table 7](#) below).

**Table 7. Gain set in active mode**

Gain set	4 to 2 wires gain	2 to 4 wires gain	Impedance synthesis scale factor
0	0 dB	-6 dB	x 50
1	+6 dB	-12 dB	x 25

- **Input impedance synthesis:** can be real or complex and is set by a scaled (x 50 or x 25) external ZAC impedance
- **Transmit and receive:** The AC signal present on the 2W port (TIP and RING pins) is transferred to the Tx output with a -6 dB or -12 dB gain and from the Rx input to the 2W port with a 0 dB or +6 dB gain
- **2 to 4 wires conversion:** The balance impedance can be real or complex, the proper cancellation is obtained by means of two external impedances ZA and ZB

Once in active mode (D1=1) the SLIC can operate in different states setting properly D0 and D2 control bits (see also [Table 8](#)).

**Table 8. SLIC states in active mode**

D0	D1	D2	Operating mode
0	1	0	Active normal polarity
0	1	1	Active reverse polarity
1	1	0	Active TTX injection (normal polarity.)
1	1	1	Active TTX injection (reverse polarity.)

## Polarity reversal

The D2 bit controls the line polarity, the transition between the two polarities is performed in a 'soft' way. This means that the TIP and RING wires exchange their polarities following a ramp transition (see [Figure 5](#)). The transition time is controlled by an external capacitor CREV. This capacitor also sets the shape of the ringing trapezoidal waveform. When the control pins set the battery reversal, the line polarity is reversed with a proper transition time set via an external capacitor (CREV).

**Figure 5. TIP/RING typical transition from direct to reverse polarity**

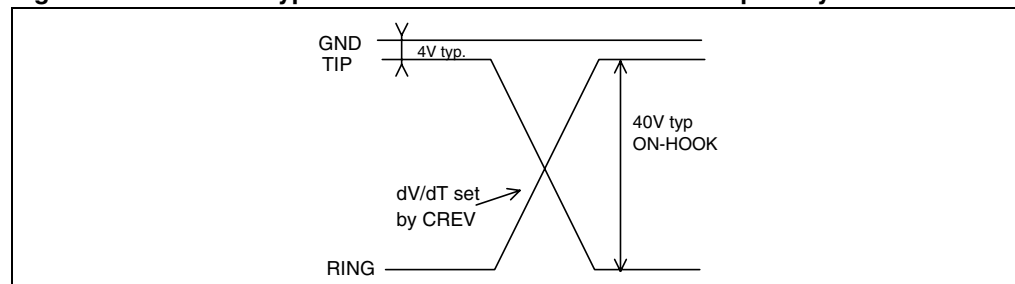

## Metering pulse injection (TTX)

The metering pulses circuit consists of a burst shaping generator that generates a square shaped wave and a low pass filter to reduce the harmonic distortion of the output signal.

The metering pulse is obtained from two logic signals:

- **CKTTX**: is a square wave at the TTX frequency (12 or 16KHz) that must be permanently applied to the CKTTX pin or at least for all the duration of the TTX pulse (including rising and decay phases).
- **D0**: enables the TTX generation circuit and defines the TTX pulse duration.

These two signals are processed by a dedicated circuitry integrated on chip that generates the metering pulse as an amplitude modulated shaped square wave (SQTTX) (see [Figure 6](#)).

Both the amplitude and the envelope of the square wave (SQTTX) can be programmed by means of external components. In particular the amplitude is set by the two RLV resistors while the shaping is set by the CS capacitor.

**Figure 6. Metering pulse generation circuit**

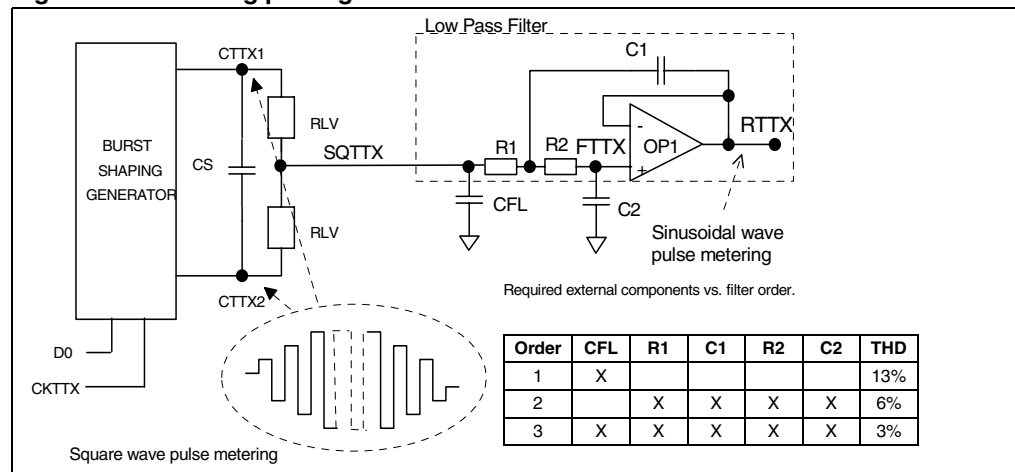

The waveform so generated is then filtered and injected on the line.

The low pass filter is obtained by using the integrated buffer OP1 connected between pin FTTX (OP1 non inverting input) and RTTX (OP1 output) (see [Figure 6](#)) and by implementing a “Sallen and Key” configuration. Depending on the external components count it is possible to build an optimized application depending on the distortion level required. In particular harmonic distortion levels equal to 13 %, 6 % and 3 % can be obtained respectively with first, second and third order filters (see [Figure 6](#)).

The circuit showed in the “Application diagram” is related to the simple first order filter.

Once the shaped and filtered signal is obtained at RTTX buffer output it is injected on the TIP/RING pins with a +6 dB gain or +12 dB gain.

It should be noted that this is the nominal condition obtained in presence of ideal TTX echo cancellation (obtained via proper setting of RTTX and CTTX).

In addition the effective level obtained on the line will depend on the line impedance and the protection resistors value. In typical applications (TTX line impedance =200  $\Omega$ , RP = 50  $\Omega$ ,

and ideal TTX echo cancellation), the metering pulse level on the line equals 1.33 or 2.66 times the level applied to the RTTX pin.

As already mentioned the metering pulse echo cancellation is obtained by means of two external components (RTTX and CTTX) that should match the line impedance at the TTX frequency. This simple network has a double effect:

- it synthesizes a low output impedance at the TIP/RING pins at the TTX frequency
- it cuts the eventual TTX echo that would have been transferred from the line to the TX output

#### 4.2.4 Ringing

When this mode is selected, the STLC3075 self generates a higher negative battery (-70 V typ.) in order to allow a balanced ringing signal of typically 65 V peak.

In this condition both the DC and AC feedback loops are disabled and the SLIC line drivers operate as voltage buffers. The ring waveform is obtained by toggling the D2 control bit at the desired ring frequency. This bit in fact controls the line polarity (0=direct; 1= reverse). As in the active mode the line voltage transition is performed with a ramp transition, obtaining in this way a trapezoidal balanced ring waveform (see [Figure 7](#)). The shaping is defined by the CREV external capacitor.

**Figure 7. TIP/RING typical ringing waveform**

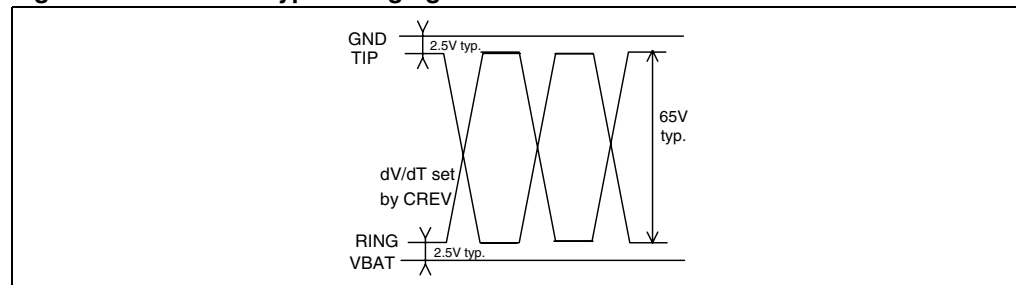

Selecting the proper capacitor value it is possible to get different crest factor values.

The following table shows the crest factor values obtained with a 20 Hz and 25 Hz ring frequency and with 1REN. These value are valid either with European or USA specification:

**Table 9. CREST factor values @ 20 and 25Hz**

CREV	CREST factor @20Hz	CREST factor @25Hz
22 nF	1.2	1.26
27 nF	1.25	1.32
33 nF	1.33	Not significant <sup>(1)</sup>

1. Distortion already less than 10%

The ring trip detection is performed by sensing the variation of the AC line impedance from on-hook (relatively high) to off-hook (low). This particular ring trip method allows to operate without DC offset superimposed on the ring signal and therefore obtaining the maximum possible ring level on the load starting from a given negative battery.

It should be noted that such a method is optimized for operation on short loop applications and may not operate properly in the case of long loop applications (> 500 Ω).

Once the ring trip is detected, the  $\overline{\text{DET}}$  output is activated (logic level low). At this point the card controller or a simple logic circuit stops the D2 toggling in order to effectively disconnect the ring signal and then set the STLC3075 in the proper operating mode (normally active).

### Ring level in presence of more telephones in parallel

As already mentioned in the previous section, the maximum current that can be drawn from the  $V_{\text{POS}}$  supply is controlled and limited via the external  $R_{\text{SENSE}}$ . This also limits the power available at the self generated negative battery.

If for any reason the ringer load is too low, the self generated battery drops in order to keep the power consumption to the fixed limit and consequently the ring voltage level is also reduced.

In the typical buckboost configuration with  $R_{\text{SENSE}} = 110 \text{ m}\Omega$  the peak current from  $V_{\text{POS}}$  is limited to around 900 mA<sub>pk</sub>, which correspond to an average current of 700 mA max. In this condition the STLC3075 can drive up to 3REN with a ring frequency  $f_r=25 \text{ Hz}$  (1REN =  $1800 \Omega + 1.0 \mu\text{F}$ , European standard).

In order to drive up to 5REN (1REN=  $6930 \Omega + 8 \mu\text{F}$ , US standard) it is necessary to modify the external components as follows:

$$\text{CREV} = 15\text{nF}; \text{RD} = 2.2 \text{ k}\Omega; R_{\text{SENSE}} = 100 \text{ m}\Omega.$$

In flyback configuration the value of  $R_{\text{SENSE}} = 220 \text{ m}\Omega$  guarantees to match both European and USA standards. In order to drive 5REN (US standard) it is necessary to modify the external component:  $R_{\text{D}} = 2.2 \text{ k}\Omega$ .

## 5 Application information

### 5.1 Layout recommendation

A properly designed PCB layout is a basic issue to guarantee a correct behavior and good noise performance.

Particular care must be taken on the ground connection. Using the configurations shown on [Figure 10](#) and [Figure 11](#) permits to avoid possible problems.

The ground of the power supply ( $V_{POS}$ ) has to be connected to the center of the star, named as SYSTEM-GND. This point should show a resistance as low as possible, that means it should be a ground plane.

In particular to avoid noise problems the layout should prevent any coupling between the DC/DC converter components and analog pins that are referred to AGND (ex: RD, IREF, RTH, RLIM, VF). As a first recommendation the components CV, L, T1, D1,  $CV_{POS}$ ,  $R_{SENSE}$  should be kept as close as possible to each other and isolated from the other components.

Additional improvements can be obtained

- by decoupling the center of the star from the analog ground of STLC3075 using small chokes
- by adding a capacitor in the range of 100 nF between  $V_{POS}$  and AGND in order to filter the switch frequency on  $V_{POS}$

### 5.2 External components list

In order to properly define the external components value the following system parameters have to be defined:

- the AC input impedance shown by the SLIC at the line terminals  $Z_s$  to which the return loss measurement is referred. It can be real (typ. 600  $\Omega$ ) or complex.
- the AC balance impedance, it is the equivalent impedance of the line 'ZI' used for evaluation of the trans-hybrid loss performances (2/4 wire conversion). It is usually a complex impedance.
- the value of the two protection resistors  $R_p$  in series with the line termination.
- the line impedance at the TTX frequency  $Z_{ltx}$
- the metering pulse level amplitude measured at line termination  $V_{LOTTX}$ . In case of low order filtering,  $V_{LOTTX}$  represents the amplitude ( $V_{rms}$ ) of the fundamental frequency component (typ. 12 or 16 kHz)
- the pulse metering envelope rise and decay time constant  $\tau$
- the slope of the ringing waveform  $\Delta V_{TR}/\Delta T$
- the value of the constant current limit current 'Ilim'
- the value of the off-hook current threshold  $I_{TH}$
- the value of the ring trip rectified average threshold current  $I_{RTH}$
- the value of the required self generated negative battery  $V_{BATR}$  in ring mode (max value is 70V). This value can be obtained from the desired ring peak level + 5V.
- the value of the maximum current peak drawn from  $V_{POS}$  'IPK'.



Table 10. External components for buckboost configuration

Name	Function	Formula	Typ. value
RRX	Rx input bias resistor		100 k $\Omega$ 5%
RREF	Bias setting current	$RREF = 1.3/I_{bias}$ $I_{bias} = 50 \mu A$	26 k $\Omega$ 1%
CSVR	Negative battery filter	$CSVR = 1/(2\pi \cdot f_p \cdot 1.8 M\Omega)$ $f_p = 50 \text{ Hz}$	1.5 nF 10% 100 V
RD	Ring trip threshold setting resistor	$RD = 100/I_{RTH}$ $2 \text{ k}\Omega < RD < 5 \text{ k}\Omega$	4.12 k $\Omega$ 1% @ $I_{RTH} = 24 \text{ mA}$
CAC	AC/DC split capacitance		22 $\mu F$ 20% 15 V @ $RD = 4.12 \text{ k}\Omega$
RP	Line protection resistor	$R_p > 30 \Omega$	50 $\Omega$ 1%
RLIM	Current limiting programming	$RLIM = 1300/I_{lim}$ $32.5 \text{ k}\Omega < RLIM < 65 \text{ k}\Omega$	52.3 k $\Omega$ 1% @ $I_{lim} = 25 \text{ mA}$
RTH	Off-hook threshold programming (Active mode)	$RTH = 290/I_{TH}$ $27 \text{ k}\Omega < RTH < 52 \text{ k}\Omega$	32.4 k $\Omega$ 1% @ $I_{TH} = 9 \text{ mA}$
CREV	Reverse polarity transition time programming	$CREV = ((1/3750) \cdot \Delta T/\Delta V_{TR})$	22 nF 10% 10V @ 12 V/ms
RDD	Pull up resistors		100 k $\Omega$
CVCC	Internally supply filter capacitor		100 nF 20% 10 V
CVPOS	Positive supply filter capacitor with low impedance for switch mode power supply		100 $\mu F^{(1)}$
CV	Battery supply filter capacitor with low impedance for switch mode power supply		100 $\mu F$ 20% 100V <sup>(2)</sup>
CVB	High frequency noise filter		470 nF 20% 100 V
CRD <sup>(3)</sup>	High frequency noise filter		100 nF 10% 15 V
Q1	DC/DC converter switch P ch. MOS transistor	$R_{DS(ON)} \leq 1.2 \Omega$ , $V_{DS} = -100 \text{ V}$ Total gate charge= 20 nC max. with $V_{GS}=4.5 \text{ V}$ and $V_{DS}=1 \text{ V}$ $I_D > 500 \text{ mA}$	Possible choices: IRF9510 or IRF9520 or IRF9120 or equivalent
D1	DC/DC converter series diode	$V_r > 100 \text{ V}$ , $t_{RR} \leq 50 \text{ ns}$	SMBYW01-200 or equivalent
R <sub>SENSE</sub>	DC/DC converter peak current limiting	$R_{SENSE} = 100\text{mV}/I_{PK}$	110 m $\Omega$ @ $I_{PK} = 900 \text{ mA}$
RF1	Negative battery programming level	$250\text{k}\Omega < RF1 < 300\text{k}\Omega^{(4)}$	300 k $\Omega$ 1% @ $V_{BATR} = -70 \text{ V}$
RF2	Negative battery programming level		9.1 k $\Omega$ 1%
L	DC/DC converter inductor	DC resistance $\leq 0.1 \Omega^{(5)}$	L=100 $\mu H$ SUMIDA CDRH125 or equivalent

1.  $CV_{POS}$  should be defined depending on the power supply current capability and maximum allowable ripple
2. For low ripple application use 2x47m F in parallel.
3. Can be saved if proper PCB layout avoid noise coupling on RD pin (high impedance input).
4. RF1 sets the self generated battery voltage in RING and ACTIVE(II=0) mode as shown in [Table 11](#).  
VBATR should be defined considering the ring peak level required ( $V_{ringpeak}=VBATR - 6\text{ V typ.}$ ). This relation is valid providing that the  $V_{POS}$  power supply current capability and the  $R_{SENSE}$  programming allow to source all the current requested by the particular ringer load configuration
5. For high efficiency in HI-Z mode coil resistance @125kHz must be  $< 3\Omega$ .

**Table 11. VBAT values in RING and ACTIVE modes**

	267k $\Omega$	280k $\Omega$	294k $\Omega$	300k $\Omega$
VBAT (ACTIVE)	-46V	-48V	-49V	-50V
VBATR (RING)	-62V	-65V	-68V	-70V

Table 12. External components for flyback configuration

Name	Function	Formula	Typ. value
RRX	Rx input bias resistor		100 k $\Omega$ 5 %
RREF	Bias setting current	$RREF = 1.3/I_{bias}$ ; $I_{bias} = 50 \mu A$	26 k $\Omega$ 1%
CSV	Negative battery filter	$CSV = 1/(2\pi \cdot f_p \cdot 1.8 M\Omega)$ $f_p = 50 \text{ Hz}$	1.5 nF 10 % 100 V
RD	Ring trip threshold setting resistor	$RD = 100/I_{RTH}$ $2 \text{ k}\Omega < RD < 5 \text{ k}\Omega$	4.12 k $\Omega$ 1% @ $I_{RTH} = 24 \text{ mA}$
CAC	AC/DC split capacitance		22 $\mu F$ 20% 15 V @ $RD = 4.12 \text{ k}\Omega$
RP	Line protection resistor	$R_p > 30 \Omega$	50 $\Omega$ 1%
RLIM	Current limiting programming	$RLIM = 1300/I_{lim}$ $32.5 \text{ k}\Omega < RLIM < 65 \text{ k}\Omega$	52.3 k $\Omega$ 1% @ $I_{lim} = 25 \text{ mA}$
RTH	Off-hook threshold programming (Active mode)	$RTH = 290/I_{TH}$ $27 \text{ k}\Omega < RTH < 52 \text{ k}\Omega$	32.4 k $\Omega$ 1% @ $I_{TH} = 9 \text{ mA}$
CREV	Reverse polarity transition time programming	$CREV = ((1/3750) \cdot \Delta T/\Delta V_{TR})$	22 nF 10% 10 V @ 12 V/ms
RDD	Pull up resistors		100 k $\Omega$
CVCC	Internally supply filter capacitor		100 nF 20 % 10 V
CV <sub>POS</sub>	Positive supply filter capacitor with low impedance for switch mode power supply		100 $\mu F$ <sup>(1)</sup>
CV	Battery supply filter capacitor with low impedance for switch mode power supply		100 $\mu F$ 20 % 100 V <sup>(2)</sup>
CVB	High frequency noise filter		470 nF 20% 100 V
CRD <sup>(3)</sup>	High frequency noise filter		100 nF 10% 15 V
CZ	Flyback compensation capacitor		2.2 nF, 20 %
CSF	Sense filter capacitor		120 pF, 20 %
RSF	Sense filter resistor		1 k $\Omega$
R <sub>SENSE</sub>	DC/DC converter peak current limiting	$R_{SENSE} = 375 \text{ mV}/I_{PK}$	220 m $\Omega$ @ $I_{PK} = 1.7 \text{ A}$
Q1	DC/DC converter switch N channel MOS transistor	$R_{DS(ON)} \leq 0.05 \Omega$ , $V_{DSS} = 30 \text{ V}$ $V_{DG} = 30 \text{ V}$ , $I_D = 6.5 \text{ A}$ Low threshold drive	STN4NF03L or equivalent
D1	DC/DC converter series diode	$V_r > 350 \text{ V}$ , $t_{RR} \leq 80 \text{ ns}$	SMBYTW01-400 or equivalent
T1	DC/DC converter transformer	Flyback transformer 4W, turns ratio 1:16 for $V_{POS}$ range from 4.5 V to 8.5 V	Tyco COEV MAGNETICS MGPWG-00007 or Coilcraft FA2469-AL <sup>(4)</sup>

**Table 12. External components for flyback configuration**

Name	Function	Formula	Typ. value
T1	DC/DC converter transformer	Flyback transformer 4W, turns ratio 1:8 for $V_{POS}$ range from 8.5 V to 12 V	Tyco COEV MAGNETICS MGPWG-00008 or Coilcraft FA2470-AL <sup>(5)</sup>
RF1	Negative battery programming level	$250\text{ k}\Omega < RF1 < 300\text{ k}\Omega$ <sup>(6)</sup>	300 k $\Omega$ 1% @ $V_{BATR} = -70\text{ V}$
RF2	Negative battery programming level		9.1 k $\Omega$ 1%

1.  $CV_{POS}$  should be defined depending on the power supply current capability and maximum allowable ripple.
2. For low ripple application use 2x47m F in parallel.
3. Can be saved if proper PCB layout avoid noise coupling on RD pin (high impedance input).
4. Coilcraft type FA2469-AL, Flyback transformer 4W, 1:16 with a  $V_{POS}$  range from 4.5V to 8.5V @ +20°C unless otherwise specified. Also check [Table 13](#) for further electrical specifications
5. Coilcraft type FA2470-AL, Flyback transformer 4W, 1:8 with a  $V_{POS}$  range from 8.5V to 12V @ +20°C unless otherwise specified. Also check [Table 14](#) for further electrical specifications
6. RF1 sets the self generated battery voltage in RING and ACTIVE(I<sub>L</sub>=0) mode as as shown in [Table 11](#).  $V_{BATR}$  should be defined considering the ring peak level required ( $V_{ringpeak} = V_{BATR} - 6\text{ V typ.}$ ). This relation is valid providing that the  $V_{POS}$  power supply current capability and the  $R_{SENSE}$  programming allow to source all the current requested by the particular ringer load configuration.

**Table 13. Coilcraft type FA2469-AL electrical specifications**

Test description	Limit	Unit	Tol.	Notes
Inductance	0.0205	mH	Max	1-3, 10KHz, 100 mVrms
Leakage inductance	0.414	$\mu$ H	Max	1-3, 100KHz, 100 mVrms Short pins 4,6
DC resistance	0.036	ohm	Max	1-3
DC resistance	16.50	ohm	Max	4-6
Turns ratio	16:1	-	+/-4%	(4-6):(1-3), 10KHz, 100mVAC
HI POT	1.500	VAC		VDC to be applied for 1 second from pins 1,3 to pins 4,6. 500 $\mu$ A max leakage current

**Table 14. Coilcraft type FA2470-AL electrical specifications**

Test description	Limit	Unit	Tol.	Notes
Inductance	0.0205	mH	Max	1-3, 10 kHz, 100 mVrms
Leakage inductance	0.40	$\mu$ H	Max	1-3, 100 kHz, 100 mVrms Short pins 4,6
DC resistance	0.036	ohm	Max	1-3
DC resistance	7.92	ohm	Max	4-6
Turns ratio	8:1	-	+/-3.3%	(4-6):(1-3), 10 kHz, 100 mVAC
HI POT	1.500	VAC		VDC to be applied for 1 second from pins 1,3 to pins 4,6. 500 $\mu$ A max leakage current

Table 15. External components @gain set = 0

Name	Function	Formula	Typ. value
RS	Protection resistance image	$RS = 50 \cdot (2Rp)$	5 k $\Omega$ @ Rp = 50 $\Omega$
ZAC	Two wire AC impedance	$ZAC = 50 \cdot (Zs - 2Rp)$	25 k $\Omega$ 1% @ Zs = 600 $\Omega$
ZA <sup>(1)</sup>	SLIC impedance balancing network	$ZA = 50 \cdot Zs$	30 k $\Omega$ 1 % @ Zs = 600 $\Omega$
ZB <sup>(1)</sup>	Line impedance balancing network	$ZB = 50 \cdot Zl$	30 k $\Omega$ 1 % @ Zl = 600 $\Omega$
CCOMP	AC feedback loop compensation	$f_o = 250 \text{ kHz}$ $CCOMP = 1/(2\pi \cdot f_o \cdot 100 \cdot (Rp))$	120 pF 10 % 10 V @ Rp = 50 $\Omega$
CH	Trans-hybrid Loss frequency compensation	$CH = CCOMP$	120 pF 10 % 10 V
RTTX <sup>(2)</sup>	Pulse metering cancellation resistor	$RTTX = 50Re (Zltx+2Rp)$	15 k $\Omega$ @ Zltx = 200 $\Omega$ real
CTTX <sup>(2)</sup>	Pulse metering cancellation capacitor	$CTTX = 1/\{50 \cdot 2\pi \cdot ftx [-Im(Zltx)]\}$	100 nF 10% 10 V <sup>(3)</sup> @ Zltx = 200 $\Omega$ real
RLV	Pulse metering level resistor	$RLV = 63.3 \cdot 10^3 \cdot \alpha \cdot V_{LOTTX}$ $\alpha = ( Zltx + 2Rp / Zltx )$	16.2 k $\Omega$ @ $V_{LOTTX} = 170 \text{ mVrms}$
CS	Pulse metering shaping capacitor	$CS = \tau/(2 \cdot RLV)$	100 nF 10 % 10 V @ $\tau = 3.2 \text{ ms}$ , RLV = 16.2 k $\Omega$
CFL	Pulse metering filter capacitor	$CFL = 2/(2\pi \cdot ftx \cdot RLV)$	1.5 nF 10 % 10 V @ ftx = 12 kHz RLV = 16.2 k $\Omega$

1. In case  $Zs=Zl$ , ZA and ZB can be replaced by two resistors of same value:  $RA=RB=|Zs|$ .
2. Defining ZTTX as the impedance of RTTX in series with CTTX, RTTX and CTTX can also be calculated from the following formula:  $ZTTX=50 \cdot (Zltx+2Rp)$ .
3. In this case CTTX is just operating as a DC decoupling capacitor ( $f_p=100 \text{ Hz}$ ).

Table 16. External components @gain set = 1

Name	Function	Formula	Typ. value
RS	Protection resistance image	$RS = 50 \cdot (2Rp)$	5 k $\Omega$ @ Rp = 50 $\Omega$
ZAC	Two wire AC impedance	$ZAC = 50 \cdot (Zs - 2Rp)$	25 k $\Omega$ 1 % @ Zs = 600 $\Omega$
ZA <sup>(1)</sup>	SLIC impedance balancing network	$ZA = 50 \cdot Zs$	30 k $\Omega$ 1 % @ Zs = 600 $\Omega$
ZB <sup>(1)</sup>	Line impedance balancing network	$ZB = 50 \cdot ZI$	30 k $\Omega$ 1 % @ ZI = 600 $\Omega$
CCOMP	AC feedback loop compensation	$f_o = 250 \text{ kHz}$ $CCOMP = 1/(2\pi \cdot f_o \cdot 100 \cdot (Rp))$	120 pF 10 % 10 V @ Rp = 50 $\Omega$
CH	Trans-hybrid Loss frequency compensation	$CH = CCOMP$	120 pF 10 % 10 V
RTTX <sup>(2)</sup>	Pulse metering cancellation resistor	$RTTX = 50Re(Zltx + 2Rp)$	15 k $\Omega$ @ Zltx = 200 $\Omega$ real
CTTX <sup>(2)</sup>	Pulse metering cancellation capacitor	$CTTX = 1/\{50 \cdot 2\pi \cdot ftx [-Im(Zltx)]\}$	100 nF 10 % 10 V <sup>(3)</sup> @ Zltx = 200 $\Omega$ real
RLV	Pulse metering level resistor	$RLV = 63.3 \cdot 10^3 \cdot \alpha \cdot V_{LOTTX}$ $\alpha = ( Zltx + 2Rp / Zltx )$	16.2 k $\Omega$ @ $V_{LOTTX} = 170 \text{ mVrms}$
CS	Pulse metering shaping capacitor	$CS = \tau/(2 \cdot RLV)$	100 nF 10 % 10 V @ $\tau = 3.2 \text{ ms}$ , RLV = 16.2 k $\Omega$
CFL	Pulse metering filter capacitor	$CFL = 2/(2\pi \cdot ftx \cdot RLV)$	1.5 nF 10 % 10 V @ ftx = 12 kHz RLV = 16.2 k $\Omega$

1. In case  $Zs=ZI$ , ZA and ZB can be replaced by two resistors of same value:  $RA=RB=|Zs|$ .
2. Defining ZTTX as the impedance of RTTX in series with CTTX, RTTX and CTTX can also be calculated from the following formula:  $ZTTX=50 \cdot (Zltx+2Rp)$ .
3. In this case CTTX is just operating as a DC decoupling capacitor ( $f_p=100 \text{ Hz}$ ).



Figure 10. Application diagram with P-channel

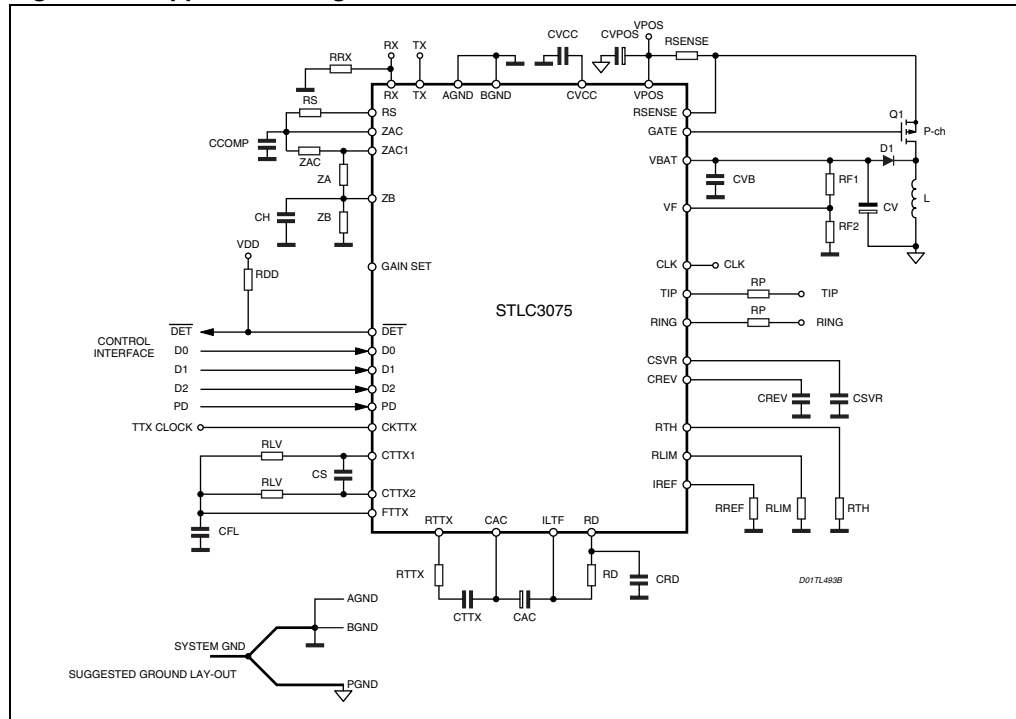
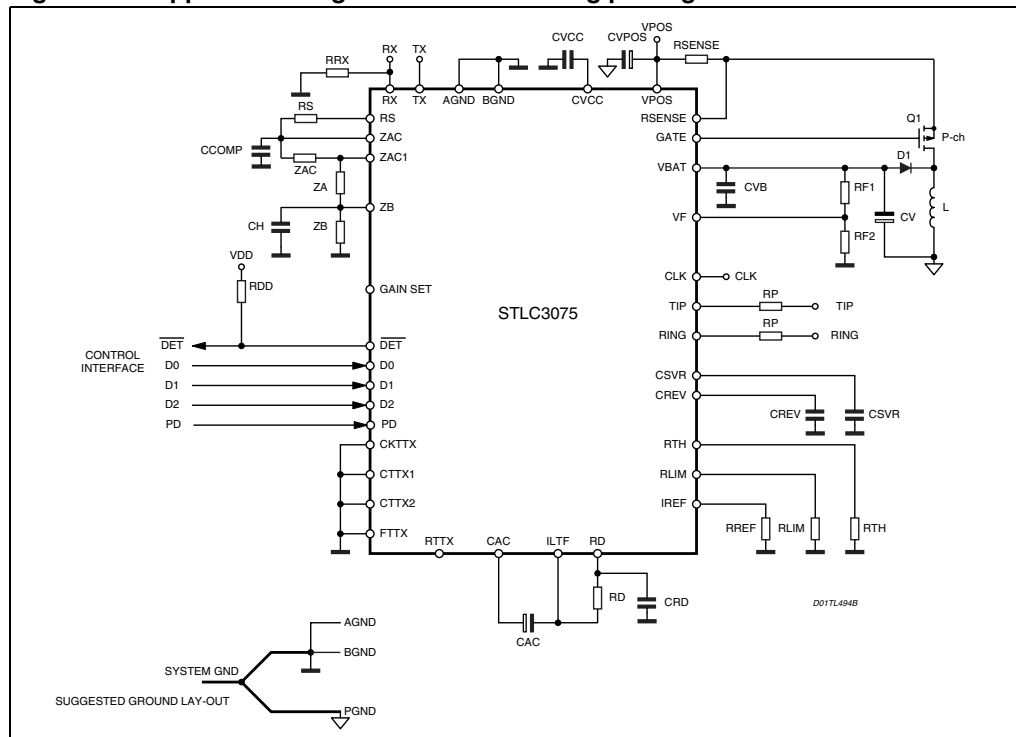

Figure 11. Application diagram without metering pulse generation



(\*) Buckboost configuration.



## 6 Electrical characteristics

Test conditions:  $V_{POS} = 6.0V$ , AGND = BGND, normal polarity,  $T_{amb} = 25^{\circ}C$ .  
External components as listed in the 'typical values' column of the above external components tables.

*Note: Testing of all parameters is performed at 25°C. Characterization as well as design rules used allow correlation of tested performances at other temperatures. All parameters listed here are met in the operating range of: -40 to +85°C.*

**Table 17. Electrical characteristics**

Symbol	Parameter	Test condition	Min.	Typ.	Max.	Unit
<b>DC characteristics</b>						
$V_{lohi}$	Line voltage	$I_l = 0$ HI-Z (High impedance feeding) $T_{amb} = 0^{\circ}C$ to $85^{\circ}C$	44	50		V
$V_{lohi}$	Line voltage	$I_l = 0$ HI-Z (High impedance feeding) $T_{amb} = -40^{\circ}C$ to $85^{\circ}C$	42	48		V
$V_{loa}$	Line voltage	$I_l = 0$ , Active mode, $T_{amb} = 0^{\circ}C$ to $85^{\circ}C$	33	40		V
$V_{loa}$	Line voltage	$I_l = 0$ , active mode, $T_{amb} = -40^{\circ}C$ to $85^{\circ}C$	31	37		V
$I_{lim}$	Lim. current programming range	Active mode	20		40	mA
$I_{lima}$	Lim. current accuracy	Active mode Rel. to programmed value 20 mA to 40mA	-10		10	%
Rfeed HI	Feeding resistance	HI-Z (High Impedance feeding)	2.4		3.6	k $\Omega$
<b>AC characteristics</b>						
L/T	Long. to transv. (see appendix for test circuit)	$R_p = 50 \Omega$ , 1% tolerance Active N. P., $R_L = 600 \Omega$ (*) $f = 300$ to $3400$ Hz	50	58		dB
T/L	Transv. to long. (see appendix for test circuit)	$R_p = 50 \Omega$ , 1 % tolerance Active N. P., $R_L = 600 \Omega$ (*) $f = 300$ to $3400$ Hz	40	45		dB
T/L	Transv. to long. (see appendix for test circuit)	$R_p = 50 \Omega$ , 1% tolerance Active N. P., $R_L = 600 \Omega$ (*) $f = 1$ kHz	48	53		dB
2WRL	2W return loss	300 to 3400 Hz Active N. P., $R_L = 600 \Omega$ (*)	22	26		dB

Table 17. Electrical characteristics (continued)

Symbol	Parameter	Test condition	Min.	Typ.	Max.	Unit
THL	Trans-hybrid loss	300 to 3400 Hz 20Log VRX/VTXI Active N. P., $R_L = 600 \Omega$ (*)	30			dB
Ovl	2W overload level	At line terminals on ref. imped. Active N. P., $R_L = 600 \Omega$ (*)	3.2			dBm
TXoff	TX output offset	Active N. P., $R_L = 600 \Omega$ (*)	-250		250	mV
G24	Transmit gain abs.	0 dBm @ 1020 Hz Active N. P., $R_L = 600 \Omega$ (*)	-6.4		-5.6	dB
G42	Receive gain abs.	0 dBm @ 1020 Hz Active N. P., $R_L = 600 \Omega$ (*)	-0.4		0.4	dB
G24f	TX gain variation vs. frequency	Rel. 1020 Hz; 0 dBm 300 to 3400 Hz Active N. P., $R_L = 600 \Omega$ (*)	-0.12		0.12	dB
G24f	RX gain variation vs. freq.	Rel. 1020 Hz; 0dBm 300 to 3400 Hz Active N. P., $R_L = 600 \Omega$ (*)	-0.12		0.12	dB
V2Wp	Idle channel noise at line 0dB gain set	Psophometric filtered Active N. P., $R_L = 600 \Omega$ (*) $T_{amb} = 0$ to +85 °C		-73	-68	dBmp
V2Wp	Idle channel noise at line 0dB gain set	Psophometric filtered Active N. P., $R_L = 600 \Omega$ (*) $T_{amb} = -40$ to +85 °C		-68		dBmp
V4Wp	Idle channel noise at line 0dB gain set	Psophometric filtered Active N. P., $R_L = 600 \Omega$ (*) $T_{amb} = 0$ to +85 °C		-75	-70	dBmp
V4Wp	Idle channel noise at line 0dB gain set	Psophometric filtered Active N. P., $R_L = 600 \Omega$ (*) $T_{amb} = -40$ to +85 °C		-75		dBmp
Thd	Total harmonic distortion	Active N. P., $R_L = 600 \Omega$ (*)			-44	dB
VTTX	Metering pulse level on line	Active - TTX; Gain Set = 1 $Z_I = 200 \Omega$ ftx = 12 kHz	260	340		mVrms
CLKfreq	CLK operating range		-10%	125	10%	kHz
(*) $R_L$ : Line resistance						
<b>Ring</b>						
Vring	Line voltage	RING D2 toggling @ fr = 25 Hz Load = 3REN Crest Factor = 1.25 1REN = 1800 $\Omega$ + 1.0 $\mu$ F $T_{amb} = 0$ to +85 °C	45	49		Vrms

Table 17. Electrical characteristics (continued)

Symbol	Parameter	Test condition	Min.	Typ.	Max.	Unit
Vring	Line voltage	RING D2 toggling @ fr = 25 Hz Load = 3REN Crest Factor = 1.25 1REN = 1800 $\Omega$ + 1.0 $\mu$ F T <sub>amb</sub> = -40 to +85 °C	44	48		Vrms
<b>Detectors</b>						
IOFFTHA	Off/hook current threshold	Active mode, RTH = 32.4 k $\Omega$ 1% (Prog. ITH = 9 mA)	10.5			mA
ROFFTHA	Off/hook loop resistance threshold	Active mode, RTH = 32.4 k $\Omega$ 1% (Prog. ITH = 9 mA)			3.4	k $\Omega$
IONTHA	On/hook current threshold	Active mode, RTH = 32.4 k $\Omega$ 1% (Prog. ITH = 9 mA)			6	mA
RONTHA	On/hook loop resistance threshold	Active mode, RTH = 32.4 k $\Omega$ 1% (Prog. ITH = 9 mA)	8			k $\Omega$
IOFFTHI	Off/hook current threshold	Hi Z mode, RTH = 32.4 k $\Omega$ 1% (Prog. ITH = 9 mA)	10.5			mA
ROFFTHI	Off/hook loop resistance threshold	Hi Z mode, RTH = 32.4 k $\Omega$ 1% (Prog. ITH = 9 mA)			800	$\Omega$
IONTHI	On/hook current threshold	Hi Z mode, RTH = 32.4 k $\Omega$ 1% (Prog. ITH = 9 mA)			6	mA
RONTHI	On/hook loop resistance threshold	Hi Z mode, RTH = 32.4 k $\Omega$ 1% (Prog. ITH = 9 mA)	8			k $\Omega$
Irt	Ring trip detector threshold range	Ring	20		50	mA
Irt <sub>a</sub>	Ring trip detector threshold accuracy	Ring	-15		15	%
Trtd	Ring trip detection time	Ring		60		ms
Td	Dialling distortion	Active mode	-1		1	ms
Rlrt <sup>(1)</sup>	Loop resistance				500	$\Omega$
ThAl	Tj for th. alarm activation			160		°C
(1) Rlrt = Maximum loop resistance (incl. telephone) for correct ring trip detection.						

**Digital interface**

Inputs: D0, D1, D2, PD, CLK

Outputs: DET

Vih	Input high voltage		2			V
Vil	Input low voltage				0.8	V
Iih	Input high current		-10		10	$\mu$ A
Iil	Input low current		-10		10	$\mu$ A
Vol	Output low voltage	Iol = 1mA			0.45	V

Table 17. Electrical characteristics (continued)

Symbol	Parameter	Test condition	Min.	Typ.	Max.	Unit
<b>PSRR and power consumption</b>						
PSERRC	Power supply rejection $V_{POS}$ to 2W port	Vripple = 100 mVrms 50 to 4000 Hz	26	36		dB
$I_{VPOS}$	$V_{POS}$ supply current @ $I_L = 0$	HI-Z on-hook Active on-hook RING (line open)		13 50 55	25 80 90	mA mA mA
$I_{pk}^{(1)}$	Peak current limiting accuracy	RING off-hook $R_{SENSE} = 110\text{ m}\Omega$	-20%	900	+20%	mApk

1. Buck-Boost configuration

### 6.1 Test circuits

Referring to the application diagram as shown on [Figure 10: Application diagram with P-channel](#) and using the typical values from [Table 10: External components for buckboost configuration](#) and [Table 15: External components @gain set = 0](#) find below the proper configuration for each measurement.

All measurements requiring DC current termination should be performed using 'Wandel & Glittering' DC Loop Holding Circuit GH-1' or equivalent.

Figure 12. 2W return loss  $2WRL = 20\text{Log}(|Z_{ref} + Z_s|/|Z_{ref} - Z_s|) = 20\text{Log}(E/2V_s)$

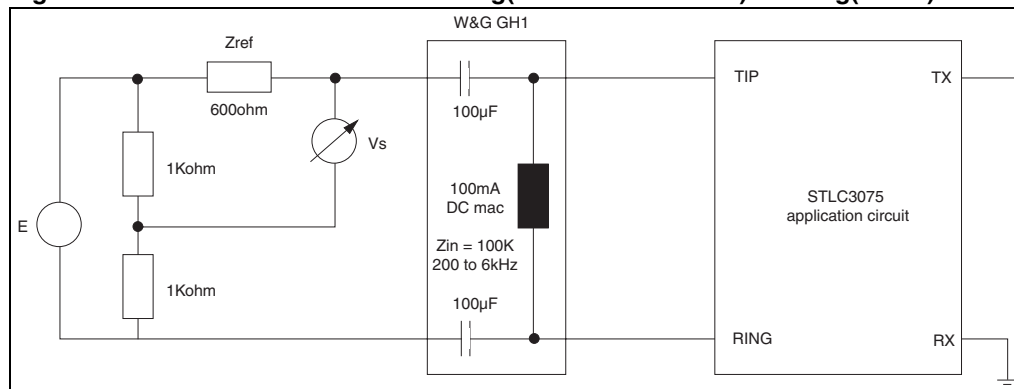

Figure 13. THL trans hybrid loss  $THL = 20\text{Log}|V_{rx}/V_{tx}|$

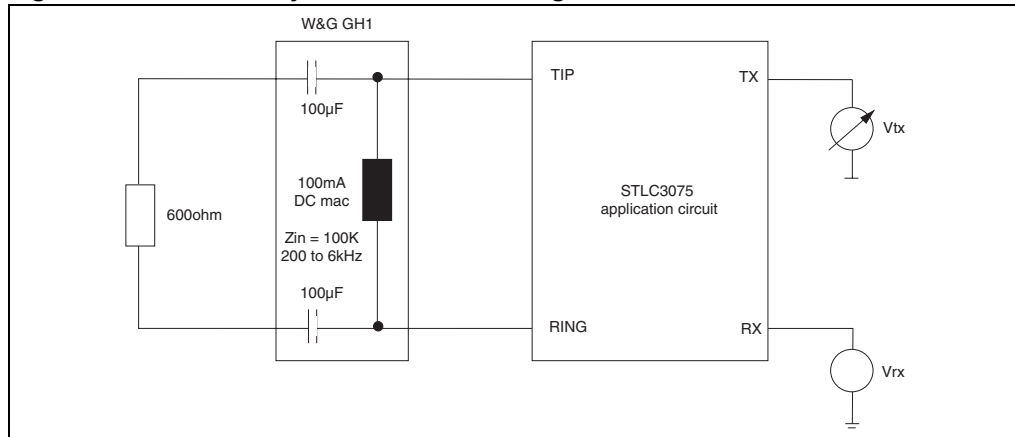

Figure 14. G24 transmit gain  $G_{24} = 20\text{Log}|2V_{tx}/E|$

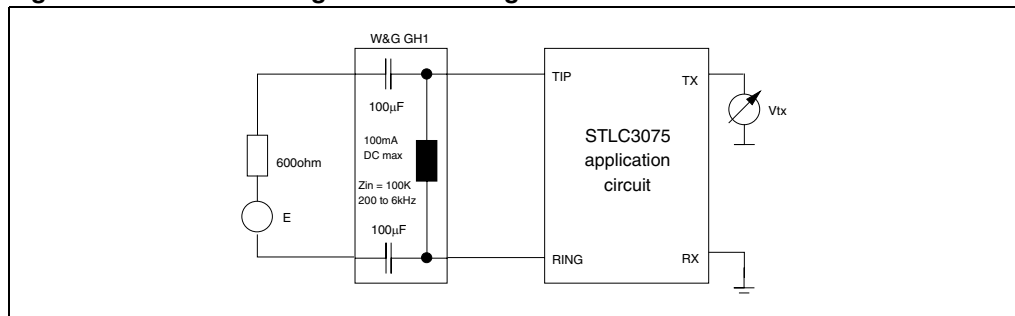

Figure 15. G42 receive gain  $G_{42} = 20\text{Log}|V_i/V_{rx}|$

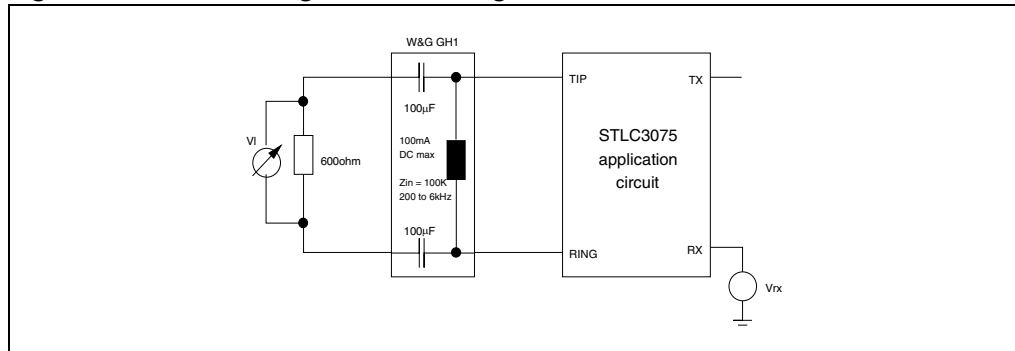

Figure 16. PSRRC power supply rejection  $V_{POS}$  to 2W port PSSRC =  $20\text{Log}|V_n/V_I|$

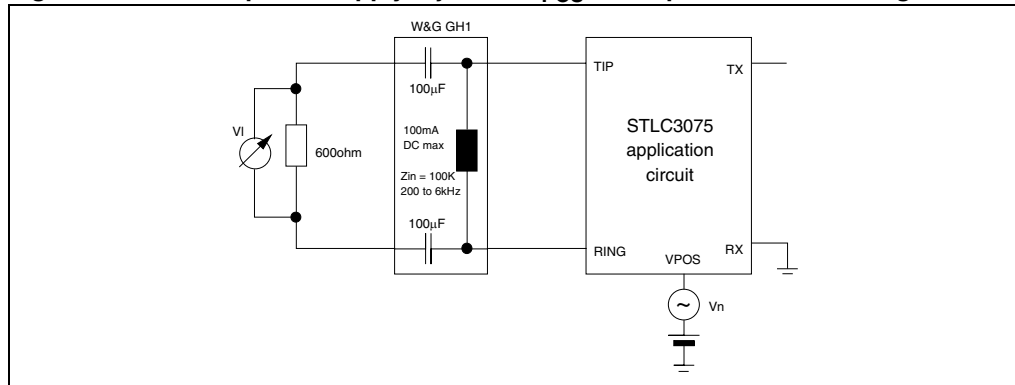

Figure 17. L/T longitudinal to transversal conversion  $L/T = 20\text{Log}|V_{cm}/V_I|$

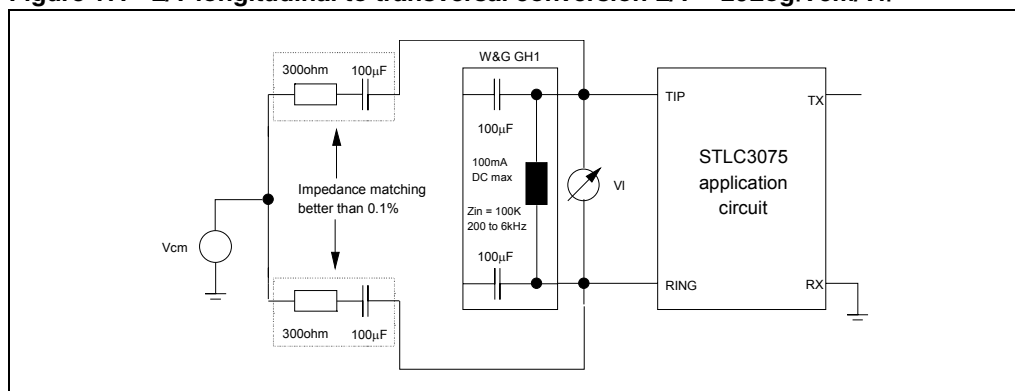

Figure 18. T/L transversal to longitudinal conversion  $T/L = 20\text{Log}|V_{rx}/V_{cm}|$

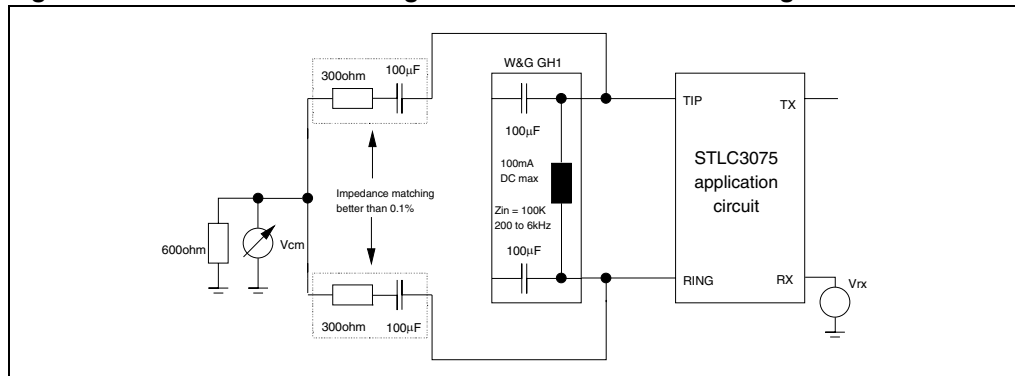

Figure 19. VTTX metering pulse level on line

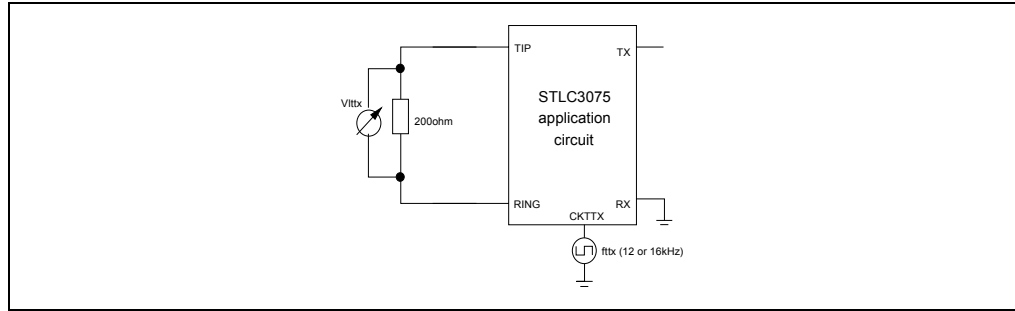
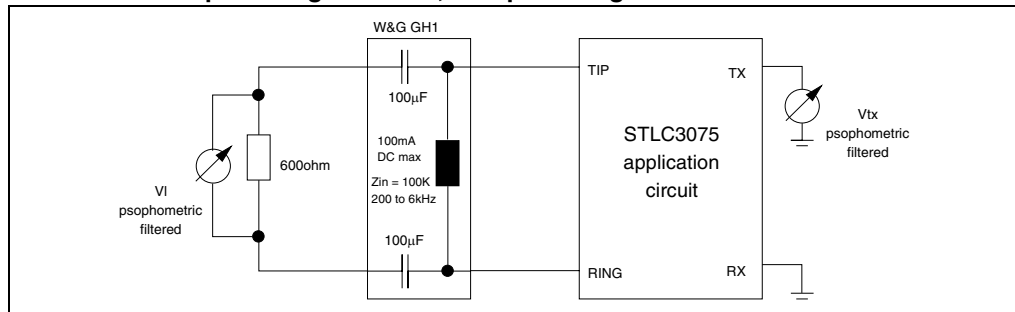
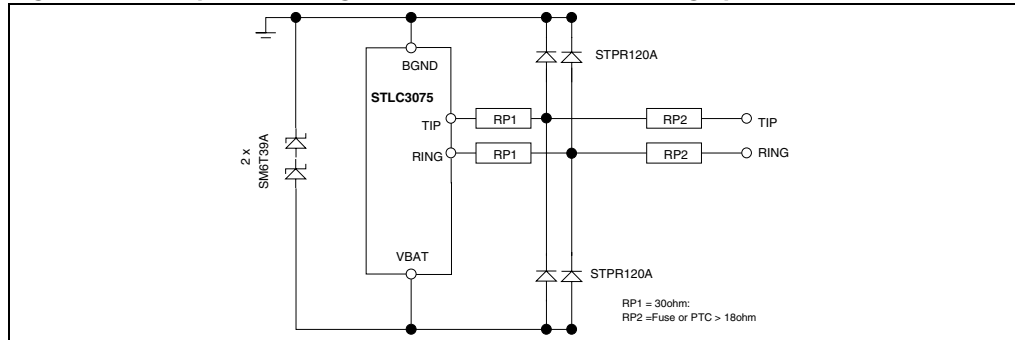

Figure 20. V2Wp and W4Wp: Idle channel sophometric noise at line and TX.  
 $V2Wp = 20\text{Log}|V_i/0.774I|$ ;  $V4Wp = 20\text{Log}|V_{tx}/0.774I|$



# 7 Over voltage protection

**Figure 21. Simplified configuration for indoor over voltage protection**



**Figure 22. Standard over voltage protection configuration for K20 compliance**

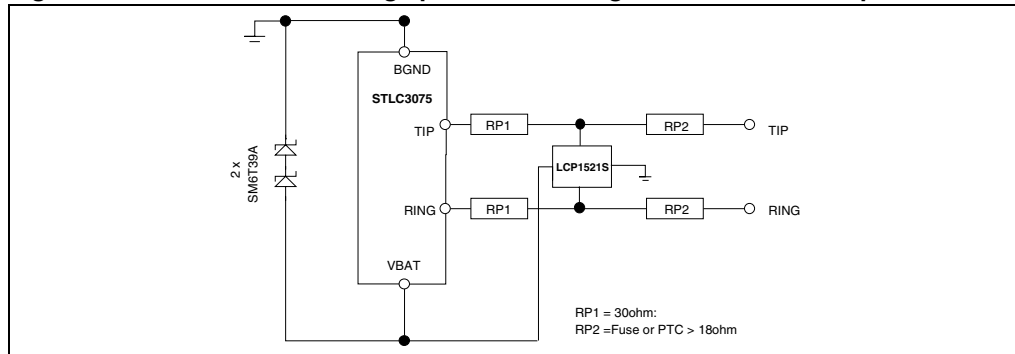



# 8 Typical state diagram

Figure 23. Typical state diagram for STLC3075 operation

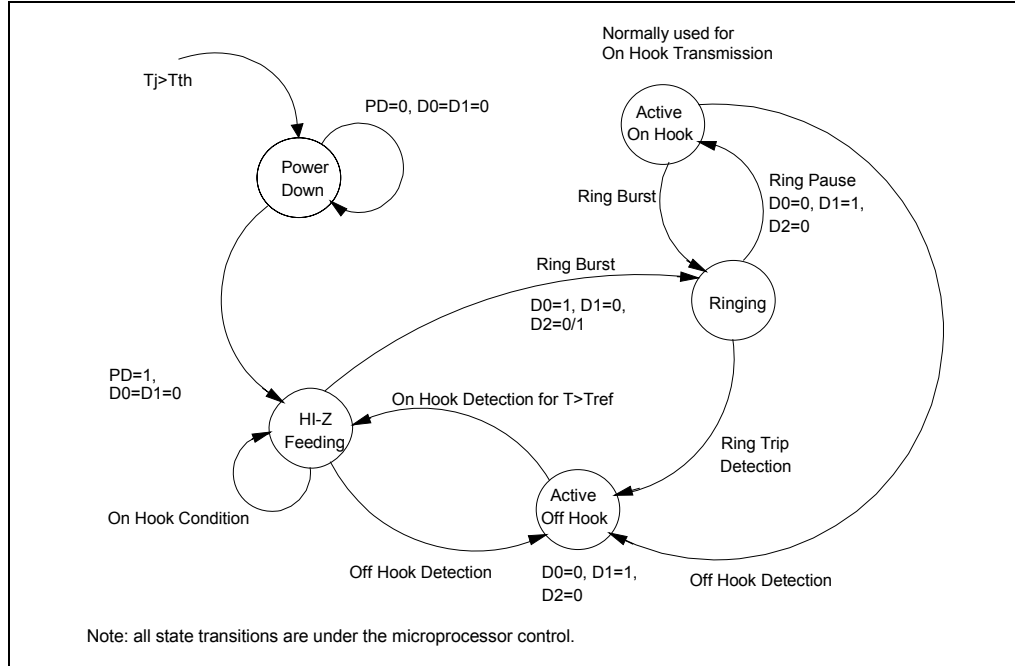

## 9 Package information

In order to meet environmental requirements, ST offers these devices in different grades of ECOPACK® packages, depending on their level of environmental compliance. ECOPACK® specifications, grade definitions and product status are available at: [www.st.com](http://www.st.com).

ECOPACK® is an ST trademark.

**Figure 24. LQFP44 (10 x 10 x 1.4 mm) mechanical data and package dimensions**

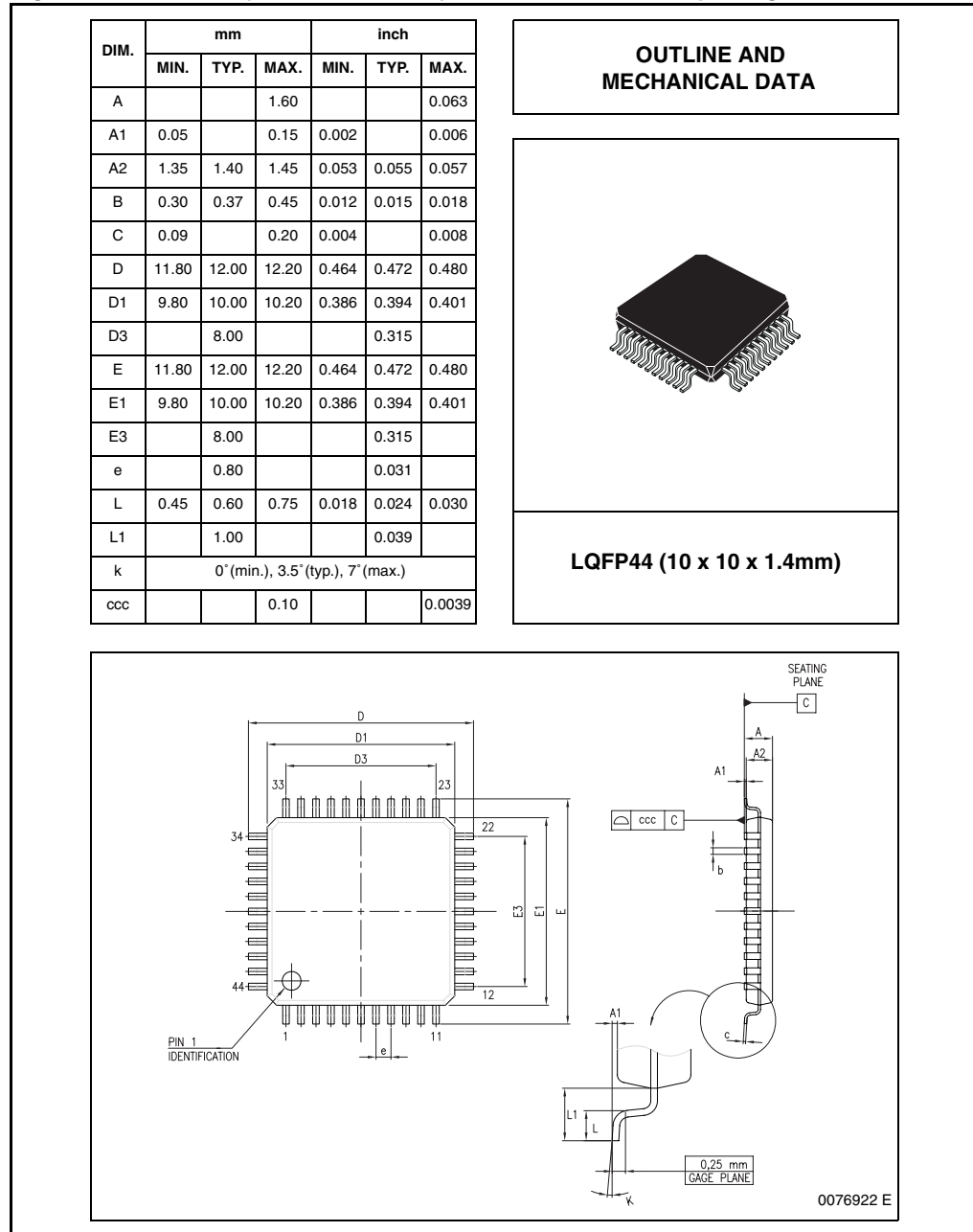

## 10 Revision history

**Table 18. Document revision history**

Date	Revision	Changes
04-Oct-2004	1	Initial release
04-Nov-2004	2	Removed all max. values of the 'Line voltage' parameter on page 16/26. Changed the unit from mA to% of the 'I <sub>lim</sub> ' parameter on page 16/26.
09-Feb-2005	3	Added pin 4 PD in applications and block diagram. Added Table 2 'ESD rating'.
22-Apr-2005	4	Changed figures 9 and 10.
14-Jul-2005	5	Changed V <sub>TTX</sub> value.
07-Feb-2007	6	Added R <sub>RRX</sub> resistance in the <a href="#">Figure 9</a> and <a href="#">Figure 10</a> . Updated <a href="#">Section 4.1</a> and <a href="#">Section 4.2.4</a> . Updated R <sub>SENSE</sub> value and I <sub>pk</sub> maximum value in <a href="#">Table 15</a> . Updated <a href="#">Figure 22</a> . Added Coilcraft references (FA2469-AL and FA2470-AL) to T1 parameter in <a href="#">Table 12</a> . Moved <a href="#">Table 3</a> , <a href="#">Table 4</a> and <a href="#">Table 5</a> to <a href="#">Chapter 9: Package information</a> .
09-Mar-2007	7	Added precision on single supply voltage range for fly-back and buck boost configurations on page 1.
10-Mar-2009	8	Document reformatted. Updated <a href="#">Section 9: Package information on page 34</a>

**Please Read Carefully:**

Information in this document is provided solely in connection with ST products. STMicroelectronics NV and its subsidiaries ("ST") reserve the right to make changes, corrections, modifications or improvements, to this document, and the products and services described herein at any time, without notice.

All ST products are sold pursuant to ST's terms and conditions of sale.

Purchasers are solely responsible for the choice, selection and use of the ST products and services described herein, and ST assumes no liability whatsoever relating to the choice, selection or use of the ST products and services described herein.

No license, express or implied, by estoppel or otherwise, to any intellectual property rights is granted under this document. If any part of this document refers to any third party products or services it shall not be deemed a license grant by ST for the use of such third party products or services, or any intellectual property contained therein or considered as a warranty covering the use in any manner whatsoever of such third party products or services or any intellectual property contained therein.

**UNLESS OTHERWISE SET FORTH IN ST'S TERMS AND CONDITIONS OF SALE ST DISCLAIMS ANY EXPRESS OR IMPLIED WARRANTY WITH RESPECT TO THE USE AND/OR SALE OF ST PRODUCTS INCLUDING WITHOUT LIMITATION IMPLIED WARRANTIES OF MERCHANTABILITY, FITNESS FOR A PARTICULAR PURPOSE (AND THEIR EQUIVALENTS UNDER THE LAWS OF ANY JURISDICTION), OR INFRINGEMENT OF ANY PATENT, COPYRIGHT OR OTHER INTELLECTUAL PROPERTY RIGHT.**

**UNLESS EXPRESSLY APPROVED IN WRITING BY AN AUTHORIZED ST REPRESENTATIVE, ST PRODUCTS ARE NOT RECOMMENDED, AUTHORIZED OR WARRANTED FOR USE IN MILITARY, AIR CRAFT, SPACE, LIFE SAVING, OR LIFE SUSTAINING APPLICATIONS, NOR IN PRODUCTS OR SYSTEMS WHERE FAILURE OR MALFUNCTION MAY RESULT IN PERSONAL INJURY, DEATH, OR SEVERE PROPERTY OR ENVIRONMENTAL DAMAGE. ST PRODUCTS WHICH ARE NOT SPECIFIED AS "AUTOMOTIVE GRADE" MAY ONLY BE USED IN AUTOMOTIVE APPLICATIONS AT USER'S OWN RISK.**

Resale of ST products with provisions different from the statements and/or technical features set forth in this document shall immediately void any warranty granted by ST for the ST product or service described herein and shall not create or extend in any manner whatsoever, any liability of ST.

ST and the ST logo are trademarks or registered trademarks of ST in various countries.

Information in this document supersedes and replaces all information previously supplied.

The ST logo is a registered trademark of STMicroelectronics. All other names are the property of their respective owners.

© 2009 STMicroelectronics - All rights reserved

STMicroelectronics group of companies

Australia - Belgium - Brazil - Canada - China - Czech Republic - Finland - France - Germany - Hong Kong - India - Israel - Italy - Japan - Malaysia - Malta - Morocco - Singapore - Spain - Sweden - Switzerland - United Kingdom - United States of America

[www.st.com](http://www.st.com)